

# BS123

LE PIC SANS NOM

Scene	Duration	Panel	Duration
001	07:01	1	07:01

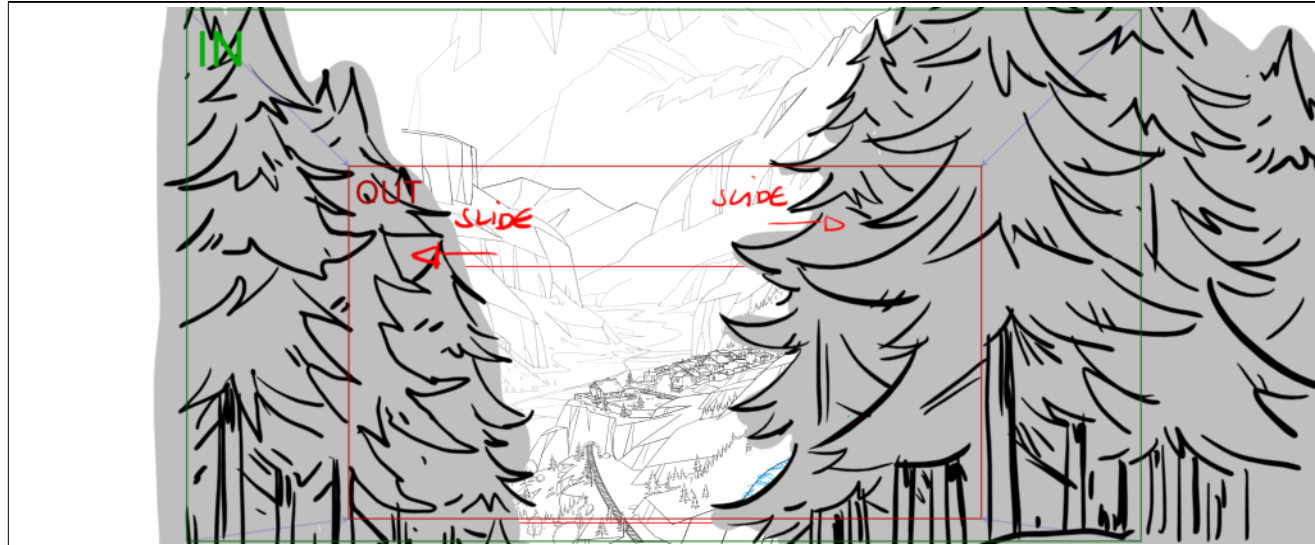

**Dialogue**

1. CAMEO (enthousiaste)  
 Et même mon arrière arrière grand-mère est née ici, dans l'ancien village de Saint-Martin.

**Action Notes**

EXT - SAINT MARTIN - JOUR

TRK IN

Scene	Duration	Panel	Duration
002	06:06	1	00:04

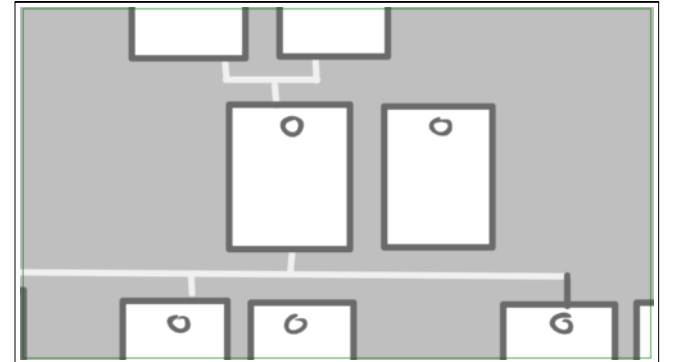

**Dialogue**

1. CAMEO (enthousiaste)  
 Son papa s'appelait

**Action Notes**

1. INT - ECOLE, SALLE DE CLASSE - JOUR  
 sur le tableau, des portraits très anciens, façon arbre généalogique, qui aboutissent aux visages de Roberte et Damien



Scene	Duration	Panel	Duration
002	06:06	2	00:22

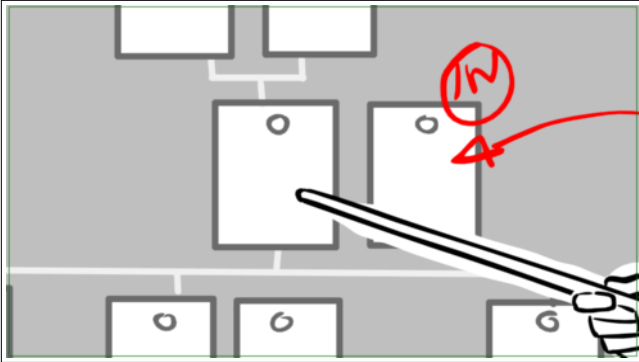

**Dialogue**

1. CAMEO (enthousiaste)  
Raymond Gordolasque...

Scene	Duration	Panel	Duration
002	06:06	3	02:09

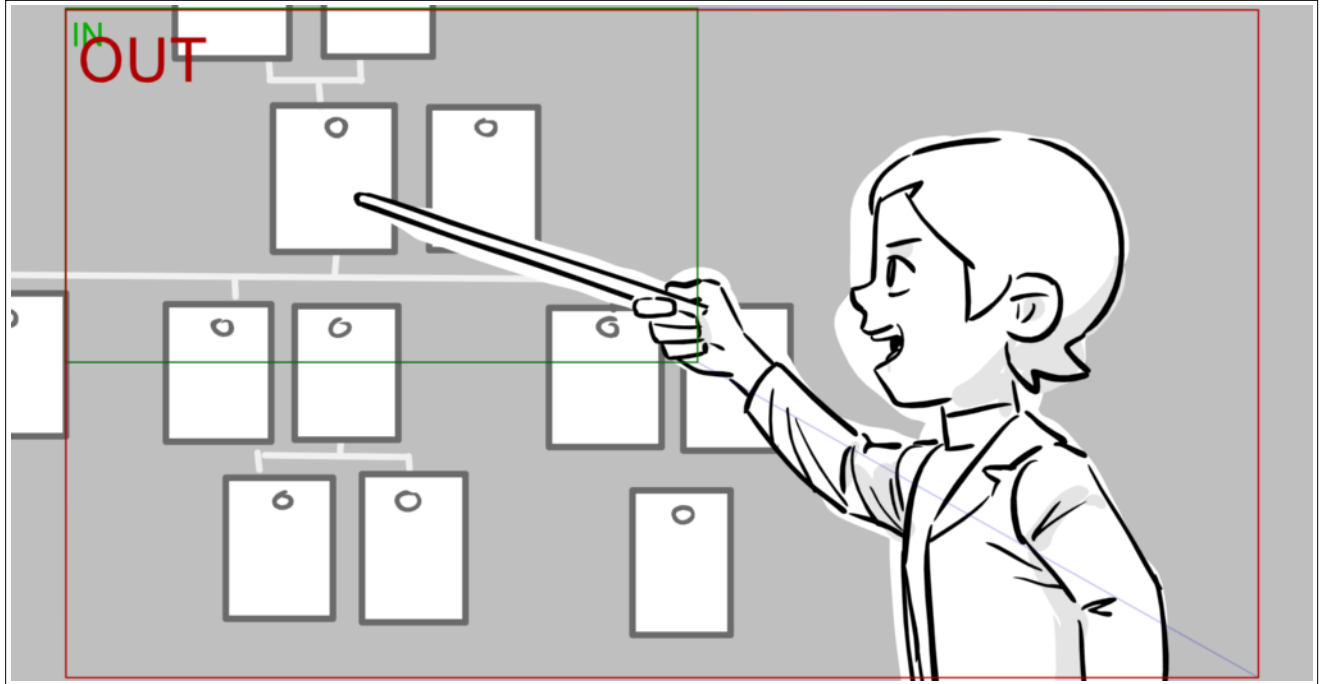

**Dialogue**

1. CAMEO (enthousiaste)  
C'est lui qui a donné son nom

**Action Notes**

TRK OUT

Scene	Duration	Panel	Duration
002	06:06	4	01:19



**Dialogue**

1. CAMEO (enthousiaste)  
à notre rivière

Scene	Duration	Panel	Duration
002	06:06	5	01:02



**Dialogue**

1. CAMEO (enthousiaste)  
La Gordolasque !

Scene	Duration	Panel	Duration
003	04:00	1	00:10

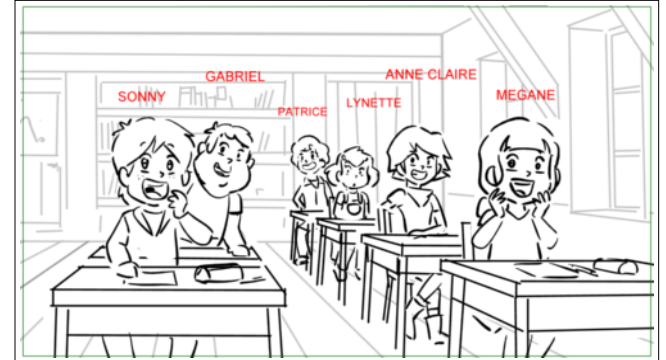

**Dialogue**

2. LES ÉLÈVES DE LA CLASSE (réaction collective, impressionnés) Waou... / C'est vrai ? / Et ben dis donc / Tu t'rends compte, il était de sa famille...

**Action Notes**

PAN OVER

Scene	Duration	Panel	Duration
003	04:00	2	02:22

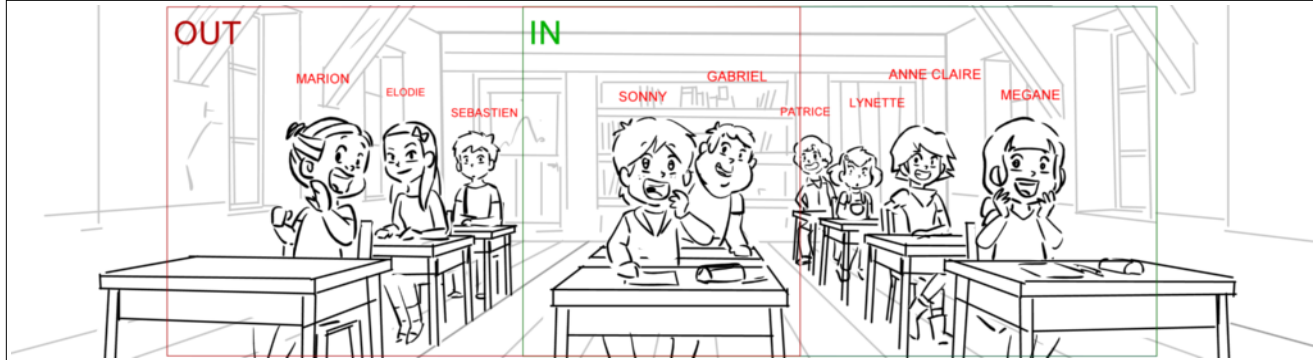

**Dialogue**

2. LES ÉLÈVES DE LA CLASSE (réaction collective, impressionnés) Waou... / C'est vrai ? / Et ben dis donc / Tu t'rends compte, il était de sa famille...

Scene	Duration	Panel	Duration
003	04:00	3	00:18

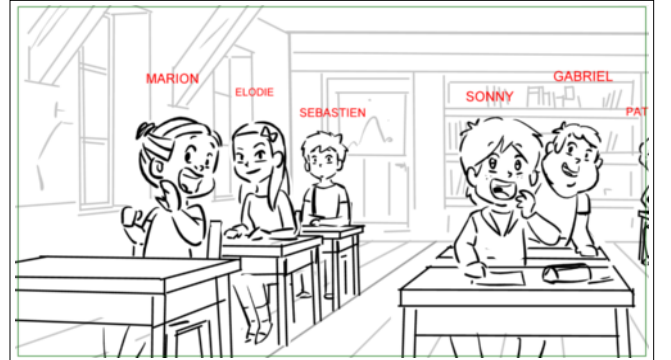

**Dialogue**

2. LES ÉLÈVES DE LA CLASSE (réaction collective, impressionnés) Waou... / C'est vrai ? / Et ben dis donc / Tu t'rends compte, il était de sa famille...

Scene	Duration	Panel	Duration
004	05:02	1	00:12



Scene	Duration	Panel	Duration
004	05:02	2	01:00



**Dialogue**

3. JEAN-BAPTISTE  
 Merci Caméo,

Scene	Duration	Panel	Duration
004	05:02	3	00:15



**Dialogue**

3. JEAN-BAPTISTE  
 tu peux retourner à ta place.

**Action Notes**

Caméo repose la baguette

Scene	Duration	Panel	Duration
004	05:02	4	01:10



**Dialogue**  
 3. JEAN-BAPTISTE  
 Je pense qu'on peut applaudir Caméo,  
 qui nous a fait un très bel exposé...

**Action Notes**  
 Jean Baptiste applaudit

Scene	Duration	Panel	Duration
004	05:02	5	01:05



**Dialogue**  
 3. JEAN-BAPTISTE  
 Je pense qu'on peut applaudir Caméo,  
 qui nous a fait un très bel exposé...

**Action Notes**  
 Cameo descend l'estrade et OUT

Scene	Duration	Panel	Duration
004	05:02	6	00:10



**Dialogue**  
 3. JEAN-BAPTISTE  
 Je pense qu'on peut applaudir Caméo,  
 qui nous a fait un très bel exposé...

**Action Notes**

Scene	Duration	Panel	Duration
005	03:13	1	01:02



**Dialogue**  
APPLAUDISSEMENTS

**Action Notes**  
Les élèves applaudissent

Scene	Duration	Panel	Duration
005	03:13	2	00:15



**Dialogue**  
APPLAUDISSEMENTS

**Action Notes**  
Caméo s'assoit

Scene	Duration	Panel	Duration
005	03:13	3	01:00



**Dialogue**  
4. JEAN-BAPTISTE  
Et je suis sûr que Caméo n'est pas le  
seul parmi nous

**Action Notes**  
Jean Baptiste IN

Scene	Duration	Panel	Duration
005	03:13	4	00:21



**Dialogue**

4. JEAN-BAPTISTE

Et je suis sûr que Caméo n'est pas le seul parmi nous

Scene	Duration	Panel	Duration
006	03:22	1	00:21



**Dialogue**

4. JEAN-BAPTISTE

à avoir des ancêtres qui ont marqué l'histoire.

Scene	Duration	Panel	Duration
006	03:22	2	01:00



**Dialogue**

4. JEAN-BAPTISTE

à avoir des ancêtres qui ont marqué l'histoire.

Scene	Duration	Panel	Duration
006	03:22	3	01:01



**Dialogue**

4. JEAN-BAPTISTE  
à avoir des ancêtres qui ont marqué l'histoire.

Scene	Duration	Panel	Duration
006	03:22	4	01:00



**Dialogue**

5. GABRIEL  
Et ben moi m'sieur,

**Action Notes**

Gabriel In levant le doigt

Scene	Duration	Panel	Duration
007	05:23	1	01:18

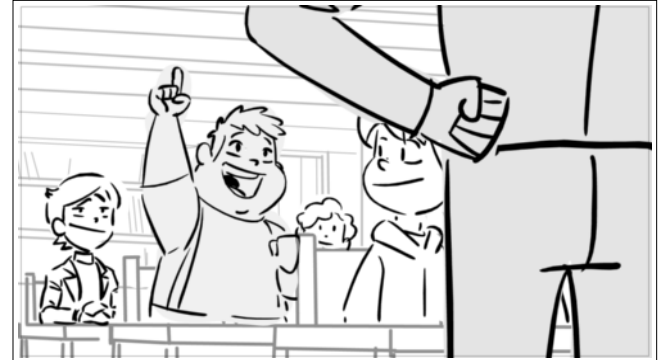

**Dialogue**

5. GABRIEL  
mon arrière grand-père,



Scene	Duration	Panel	Duration
007	05:23	2	01:09

Scene	Duration	Panel	Duration
007	05:23	3	02:21

NO PANEL

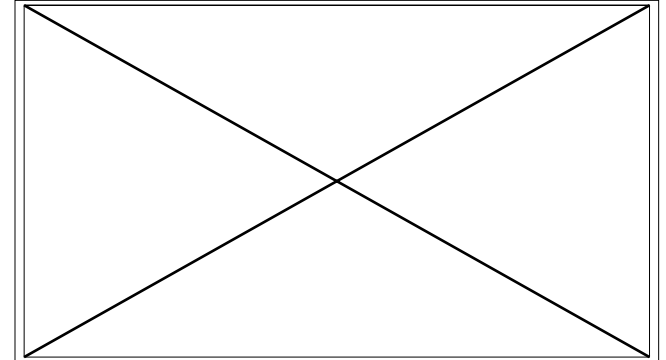
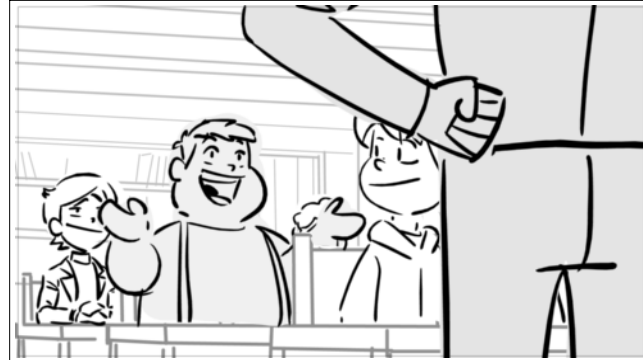
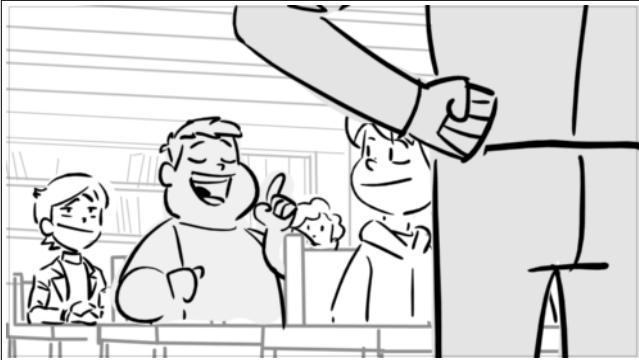

**Dialogue**  
 5. GABRIEL  
 c'est lui qui a construit la toute première maison de Saint-Martin !

**Dialogue**  
 5. GABRIEL  
 c'est lui qui a construit la toute première maison de Saint-Martin !



Scene	Duration	Panel	Duration
008	03:03	1	00:04

NO PANEL

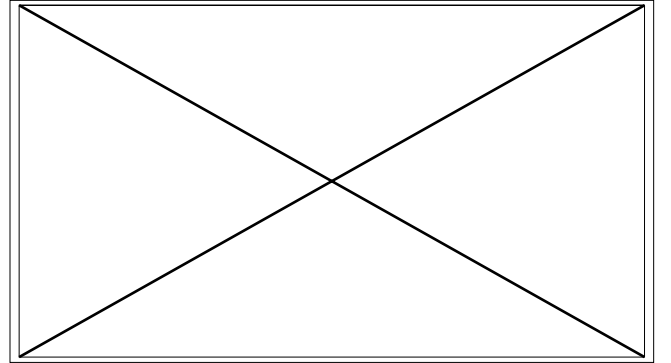
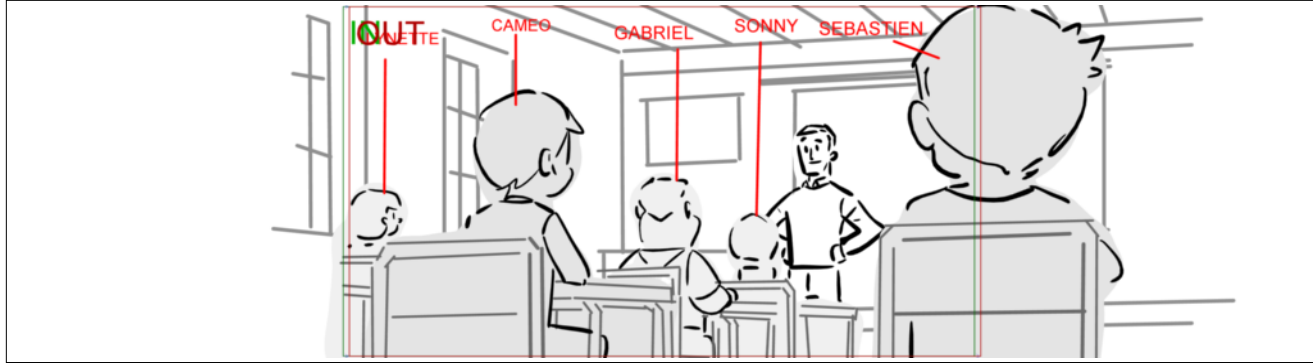

Action Notes  
PAN OVER

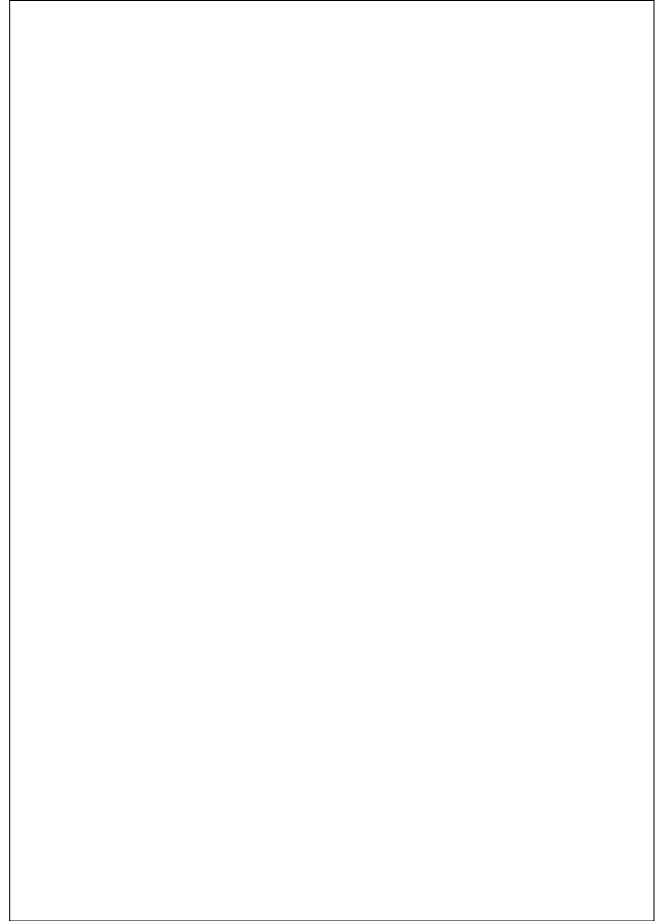

Scene	Duration	Panel	Duration
008	03:03	2	01:14

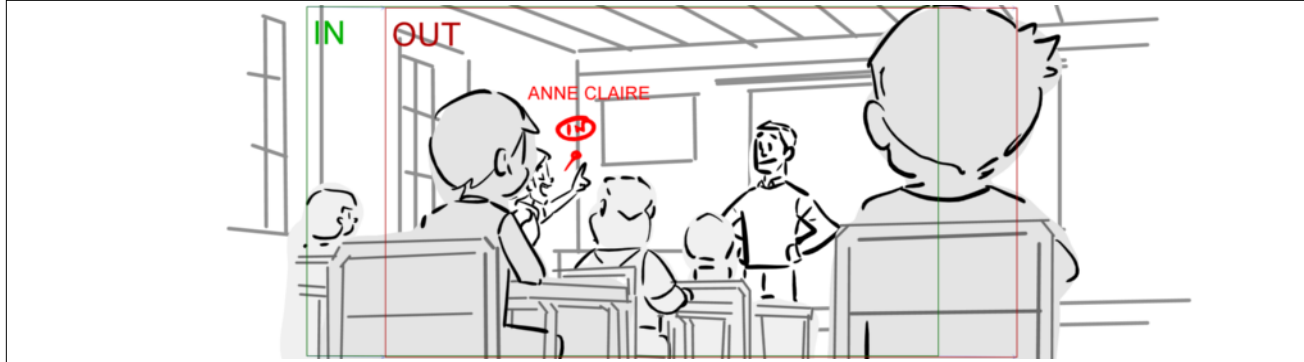

NO PANEL

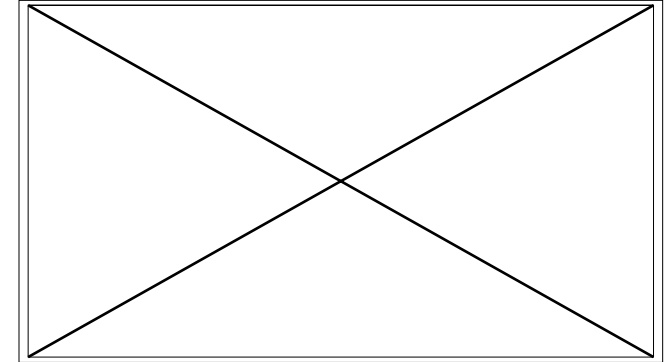

#### Dialogue

7. LES ÉLÈVES DE LA CLASSE

Moi j'ai un cousin qu'est champion de vélo

#### Action Notes

Anne Claire IN levant le doigt

Scene	Duration	Panel	Duration
008	03:03	3	01:10

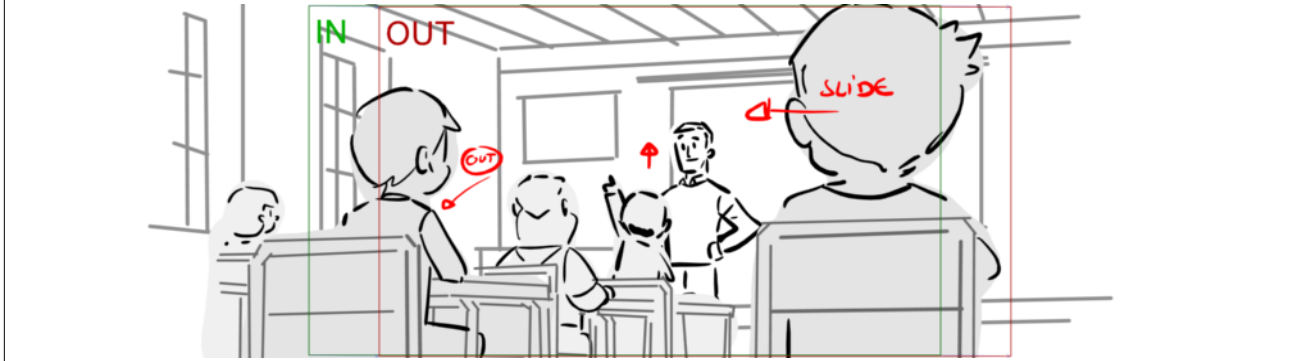
**Dialogue**

7. LES ÉLÈVES DE LA CLASSE

Le mien il a inventé le grille-pain...

**Action Notes**

Anne Claire OUT

Sonny lève le doigt

Sébastien SLIDE IN

Scene	Duration	Panel	Duration
009	02:18	1	00:14

**Dialogue**

7. LES ÉLÈVES DE LA CLASSE

Et moi mon arrière grand-père il était ministre /

Scene	Duration	Panel	Duration
009	02:18	2	00:05



**Dialogue**  
 7. LES ÉLÈVES DE LA CLASSE  
 Et moi mon arrière grand-père il était ministre /

**Action Notes**  
 SEB BLINKS

Scene	Duration	Panel	Duration
009	02:18	3	00:24



**Dialogue**  
 7. LES ÉLÈVES DE LA CLASSE  
 Et moi mon arrière grand-père il était ministre /

Scene	Duration	Panel	Duration
009	02:18	4	01:00



**Dialogue**  
 6. ELODIE  
 Et moi, ma grande-tante

Scene	Duration	Panel	Duration
010	05:19	1	01:17



**Dialogue**

6. ELODIE  
c'est la première femme à avoir gravi  
le Mont Blanc !

Scene	Duration	Panel	Duration
010	05:19	2	00:11

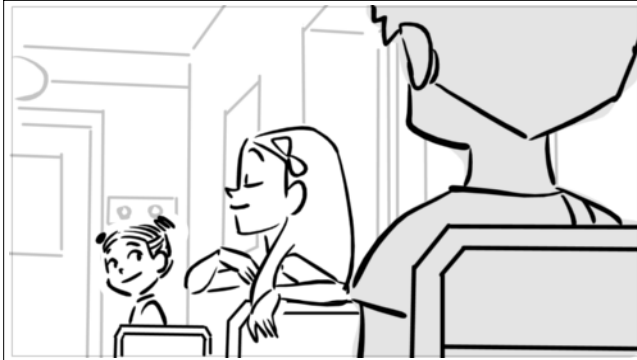

**Dialogue**

6. ELODIE  
c'est la première femme à avoir gravi  
le Mont Blanc !

Scene	Duration	Panel	Duration
010	05:19	3	00:16

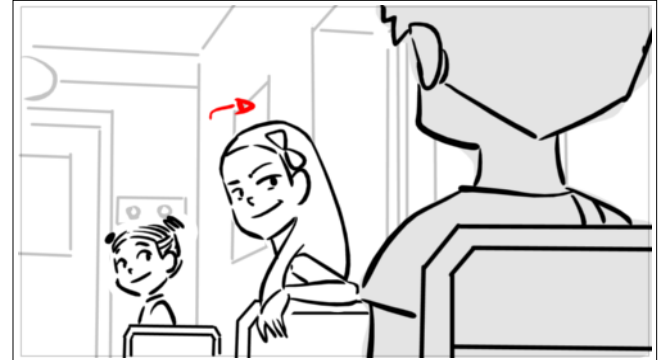

Scene	Duration	Panel	Duration
010	05:19	4	01:15

Scene	Duration	Panel	Duration
010	05:19	5	01:10

NO PANEL

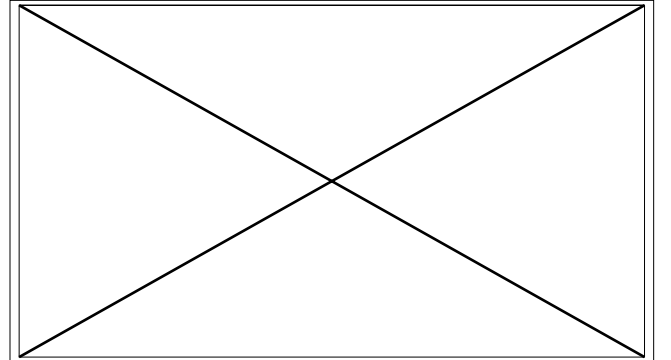
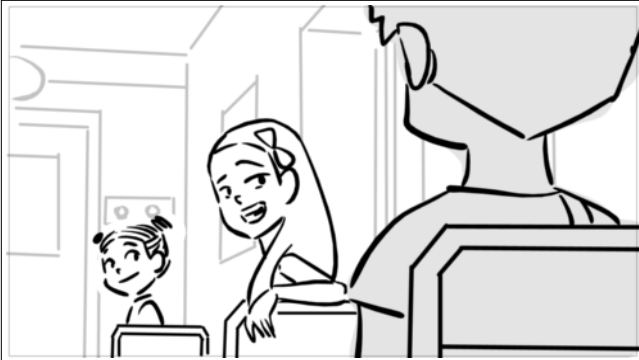

**Dialogue**  
 PU ELODIE  
 Et dans ta famille Sébastien?

**Dialogue**  
 PU ELODIE  
 Quelqu'un s'est démarqué?



Scene	Duration	Panel	Duration
011	04:13	1	00:16

NO PANEL

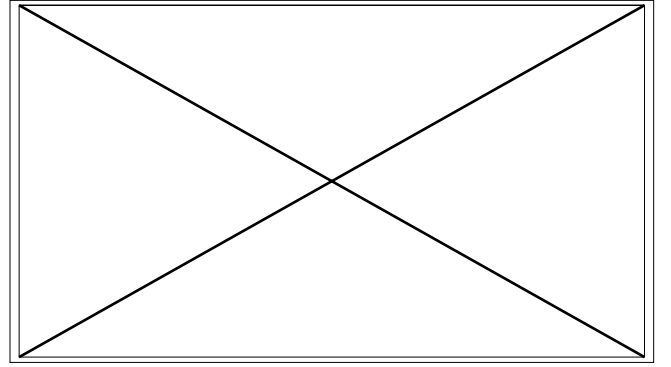

**Action Notes**

Sébastien rougit embarrassé

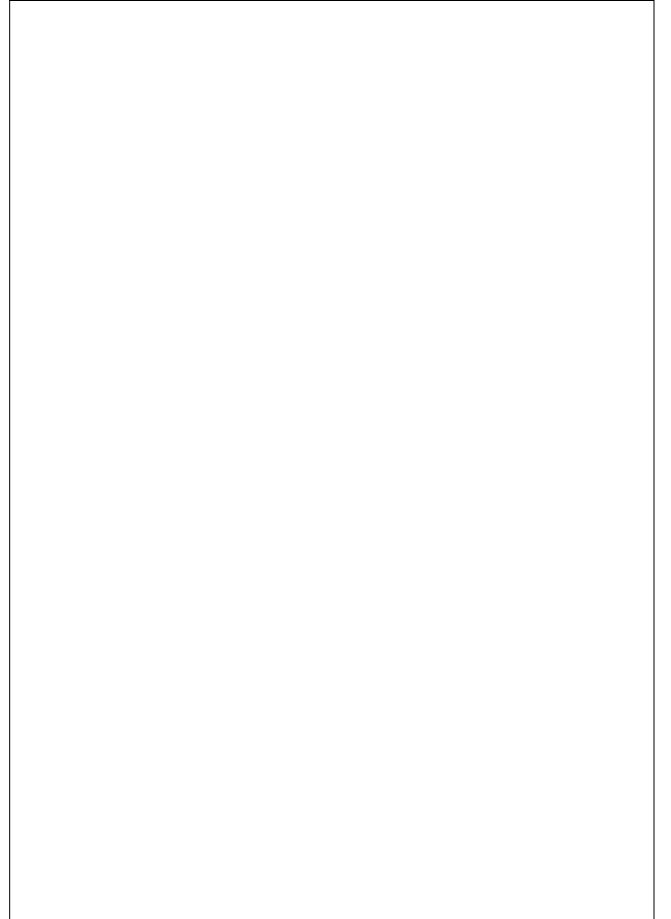



Scene	Duration	Panel	Duration
011	04:13	2	01:06

NO PANEL

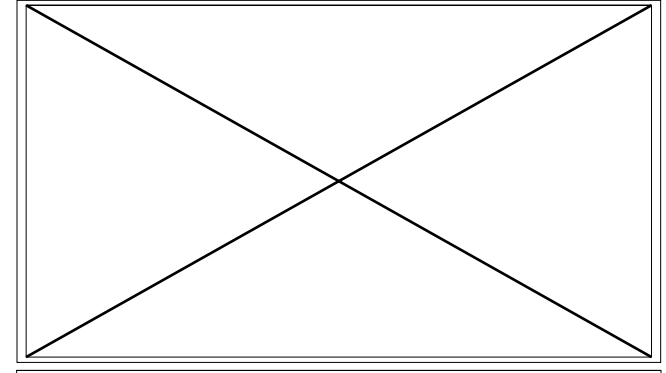

**Dialogue**

PU SEBASTIEN  
Heu....

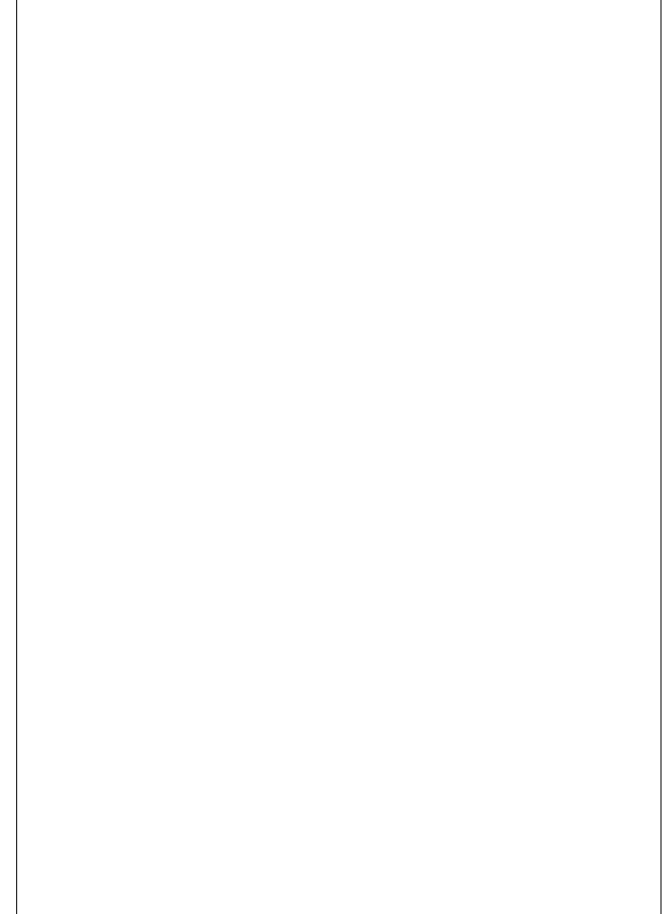

Scene	Duration	Panel	Duration
011	04:13	3	01:21

**Dialogue**

PU SEBASTIEN  
Ben je sais p....

Scene	Duration	Panel	Duration
011	04:13	4	00:20

**Dialogue**

PU ELEVE (pouffe)  
Pfff....Hi! Hi! Hi!

Scene	Duration	Panel	Duration
012	11:01	1	01:03



**Dialogue**  
 PU ELEVE  
 ça risque pas,

**Action Notes**  
 Canéo et Gabriel hilares

Scene	Duration	Panel	Duration
012	11:01	2	02:16



**Dialogue**  
 PU ELEVE  
 il a pas de famille!

NO PANEL

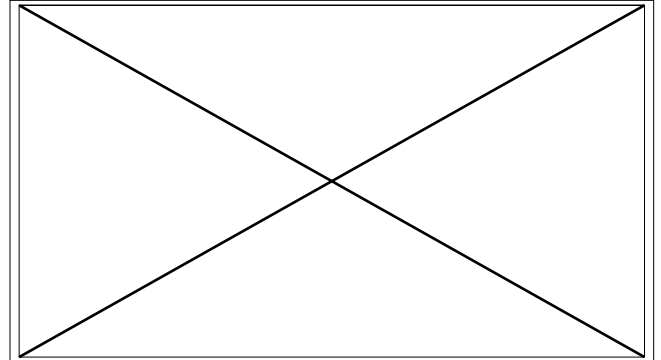

Scene	Duration	Panel	Duration
012	11:01	3	01:12

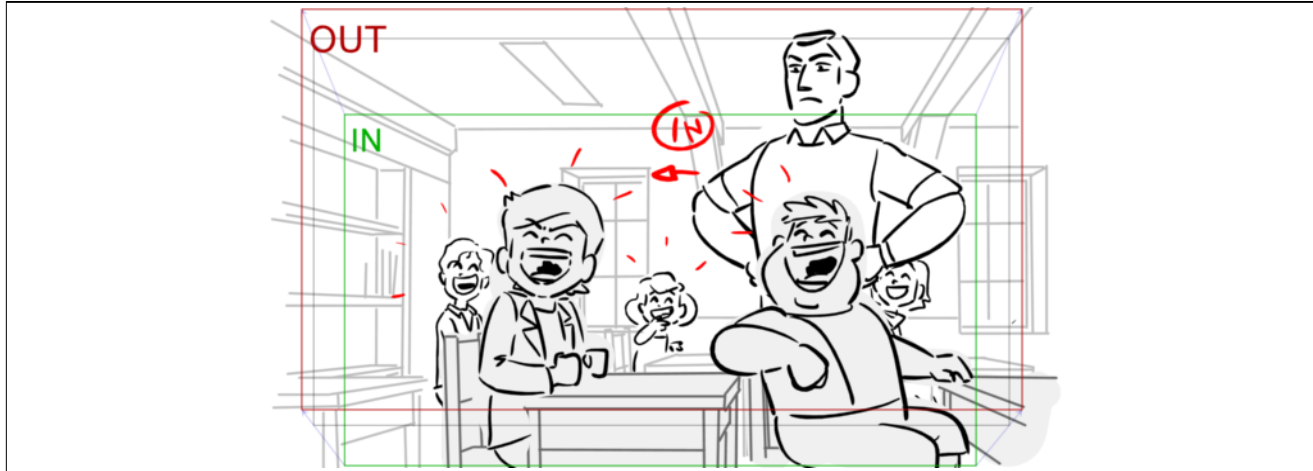

**Dialogue**  
 PU ELEVES  
 Ha! Ha! Ha!

**Action Notes**  
 PAN UP + TRK OUT  
 JB IN dans le dos de Caméo et Gabriel

Scene	Duration	Panel	Duration
012	11:01	4	00:17



**Dialogue**  
 SFX CLAP CLAP

**Action Notes**  
 REAC C+G

Scene	Duration	Panel	Duration
012	11:01	5	01:13

**Dialogue**

8. JEAN-BAPTISTE  
un peu de calme...

Scene	Duration	Panel	Duration
012	11:01	6	02:09

**Dialogue**

8. JEAN-BAPTISTE MODIF  
Peut-être qu'un jour vous aussi vous  
ferez quelque chose d'exceptionnel

**Action Notes**

JB se tourne vers SEB

Scene	Duration	Panel	Duration
012	11:01	7	01:06

**Dialogue**

8. JEAN-BAPTISTE MODIF  
Peut-être qu'un jour vous aussi vous  
ferez quelque chose d'exceptionnel

Scene	Duration	Panel	Duration
014	02:13	1	00:16



Scene	Duration	Panel	Duration
014	02:13	2	01:22



**Action Notes**

TRK IN SEB déterminé

Scene	Duration	Panel	Duration
016	05:18	1	01:15

NO PANEL

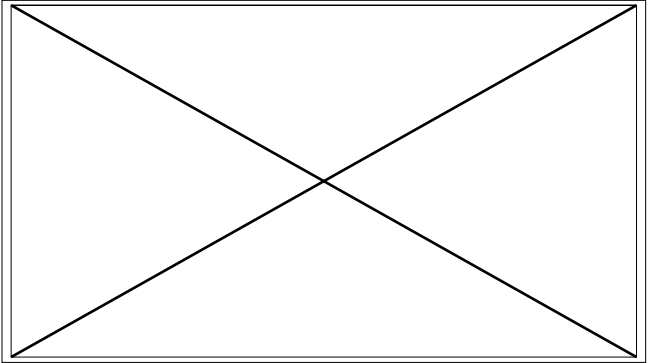
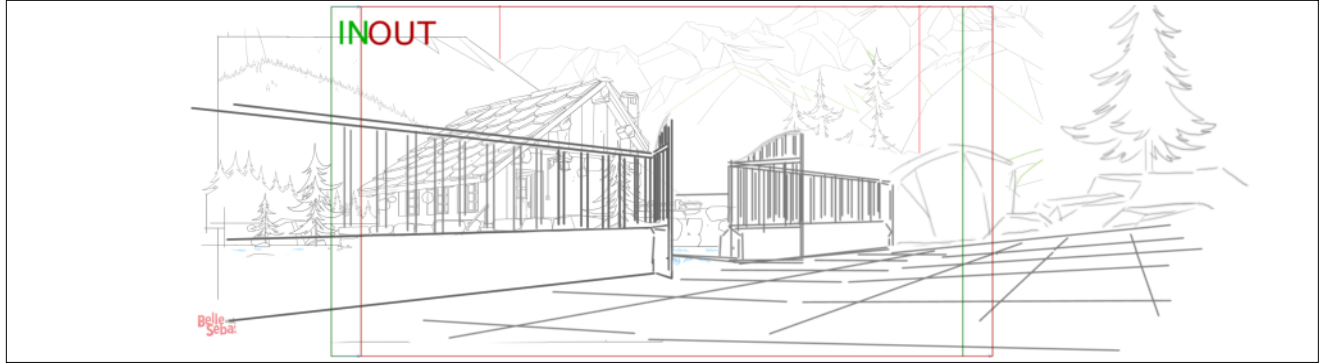

**Dialogue**  
SFX SONNERIE

**Action Notes**  
2. EXT - ECOLE, EN PASSANT LA GRILLE - JOUR

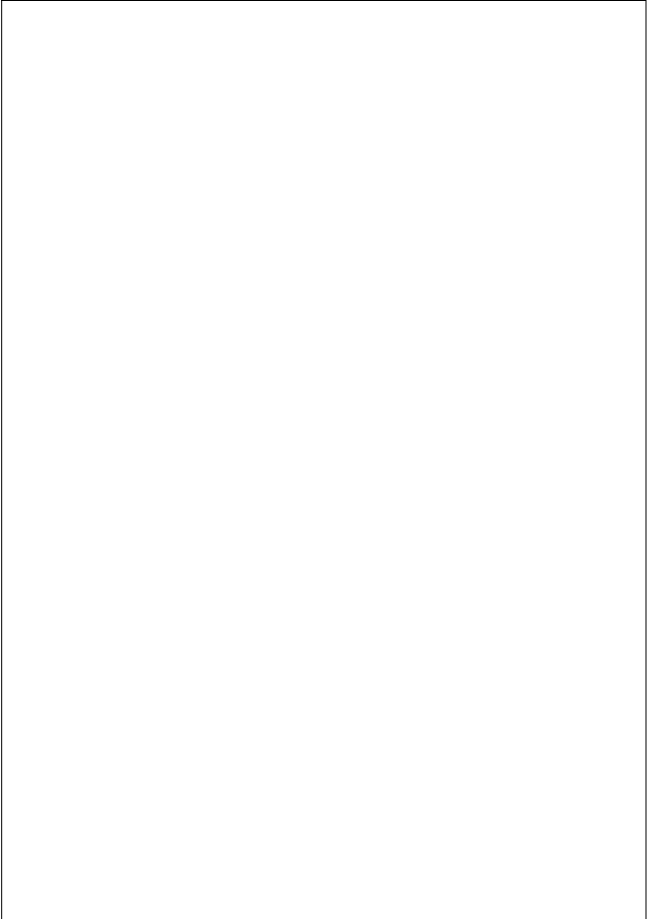

Scene	Duration	Panel	Duration
016	05:18	2	01:12

NO PANEL

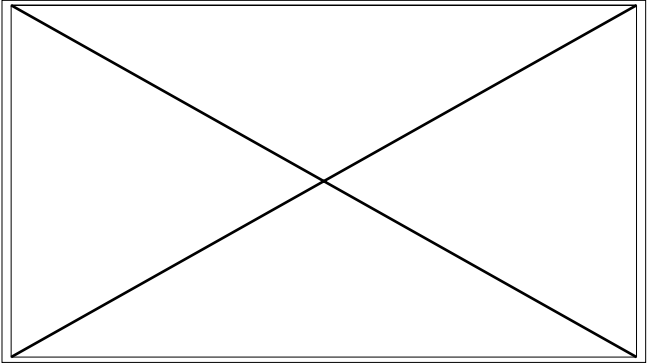
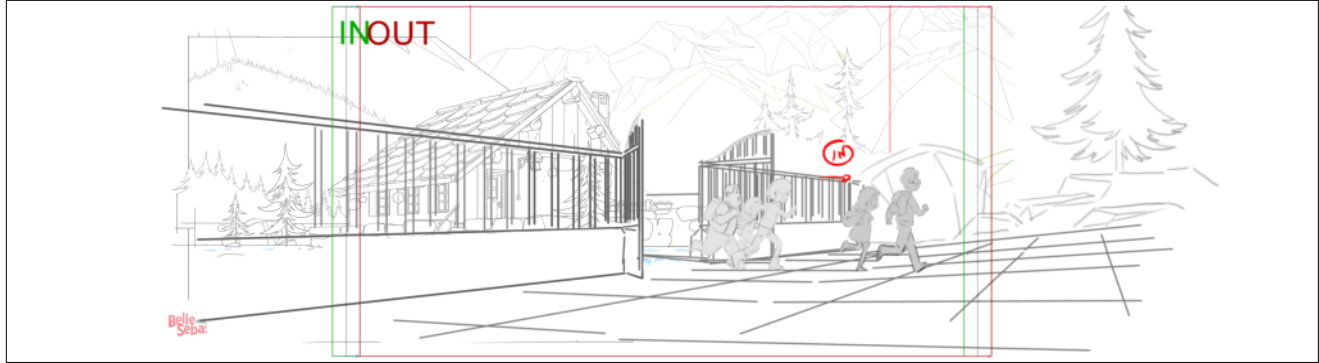

**Dialogue**  
SFX SONNERIE

**Action Notes**  
ELEVES IN/ OUT



Scene	Duration	Panel	Duration
016	05:18	3	02:16

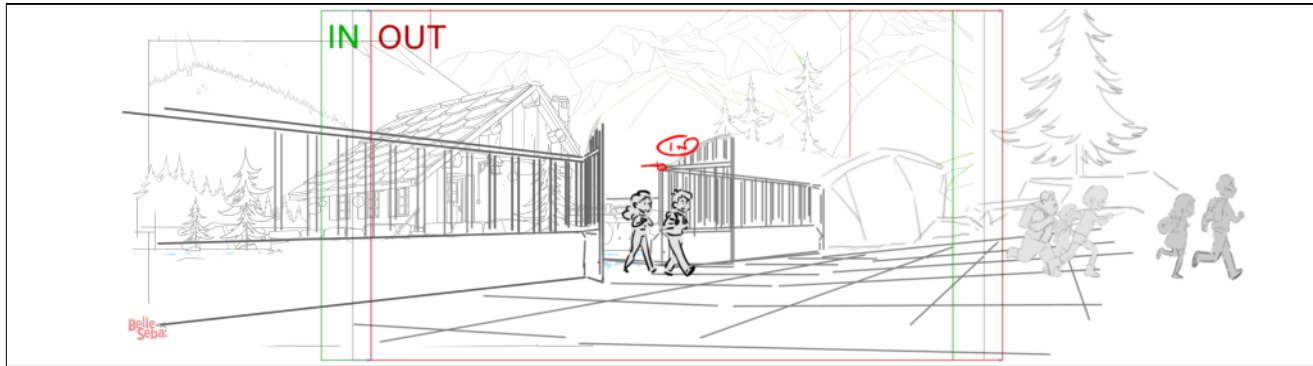

**Dialogue**

PU SEBASTIEN

Ils peuvent toujours rigoler ces nazes!

**Action Notes**

Sébastien IN discute avec Adèle.

Scene	Duration	Panel	Duration
017	05:15	1	01:20

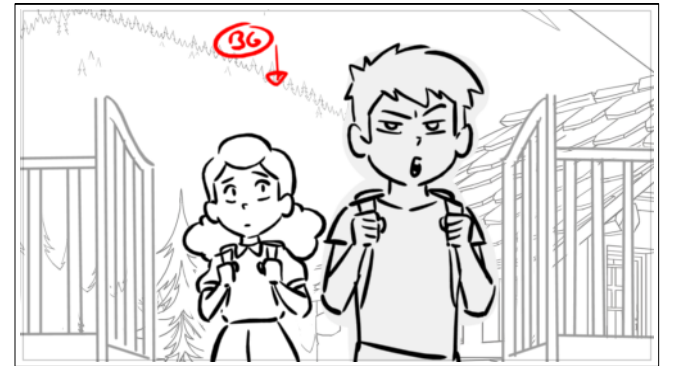

**Dialogue**

9. SEBASTIEN MODIF(exalté)

N'empêche que moi aussi je vais faire quelque chose d'exceptionnel, pour qu'on se souvienne de moi !

**Action Notes**

PAn BG

Scene	Duration	Panel	Duration
017	05:15	2	01:11

Scene	Duration	Panel	Duration
017	05:15	3	01:21

Scene	Duration	Panel	Duration
017	05:15	4	00:13

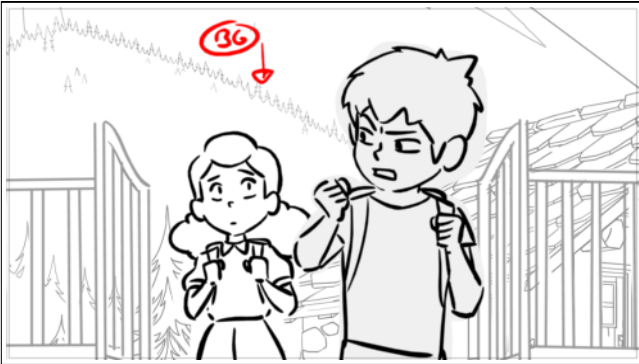

**Dialogue**  
 9. SEBASTIEN MODIF(exalté)  
 ... je vais faire quelque chose  
 d'exceptionnel, pour qu'on se souviene  
 de moi !

**Dialogue**  
 9. SEBASTIEN MODIF(exalté)  
 ... je vais faire quelque chose  
 d'exceptionnel, pour qu'on se souviene  
 de moi !

**Dialogue**  
 BELLE OFF  
 WOUF!

**Action Notes**  
 SEB se tourne vers Belle OS



Scene	Duration	Panel	Duration
018	01:02	1	00:07

Scene	Duration	Panel	Duration
018	01:02	2	00:07

Scene	Duration	Panel	Duration
018	01:02	3	00:06

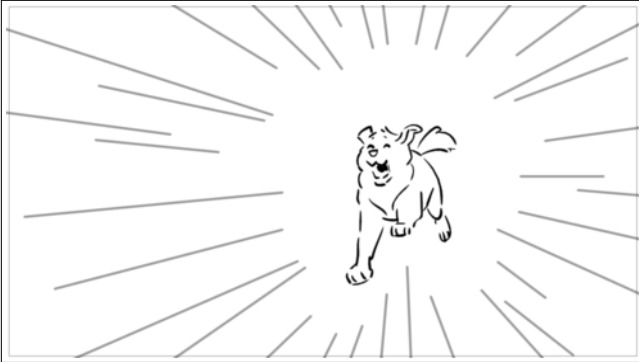

**Dialogue**  
BELLE  
WOUF! WOUF!

**Dialogue**  
BELLE  
WOUF! WOUF!

**Dialogue**  
BELLE  
WOUF! WOUF!

**Action Notes**  
BELLE court FACE CAM

Scene	Duration	Panel	Duration
018	01:02	4	00:07



**Dialogue**  
 BELLE  
 WOUF! WOUF!

Scene	Duration	Panel	Duration
019	02:20	1	01:01



**Dialogue**  
 PU SEBASTIEN  
 Belle!

Scene	Duration	Panel	Duration
019	02:20	2	00:04



**Dialogue**  
 BELLE  
 WOUF!

Scene	Duration	Panel	Duration
019	02:20	3	00:05

Scene	Duration	Panel	Duration
019	02:20	4	00:08

Scene	Duration	Panel	Duration
019	02:20	5	00:08

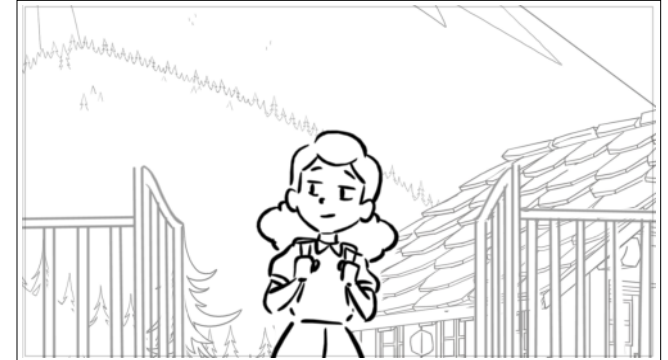

**Dialogue**  
 BELLE  
 WOUF!

**Action Notes**  
 Belle saute sur SEb en l'embarquant OUT dans son élan

Scene	Duration	Panel	Duration
019	02:20	6	00:07



**Action Notes**  
CAM SHAKE

Scene	Duration	Panel	Duration
019	02:20	7	00:12

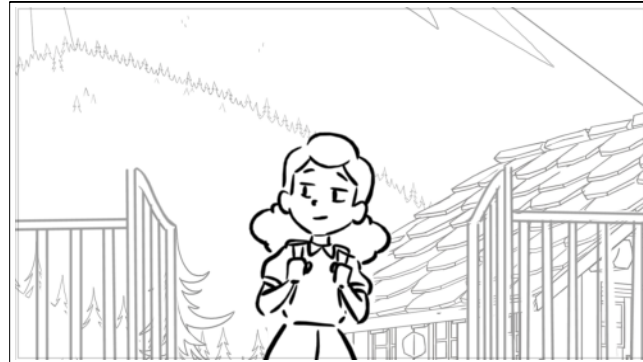

Scene	Duration	Panel	Duration
020	03:07	1	01:05

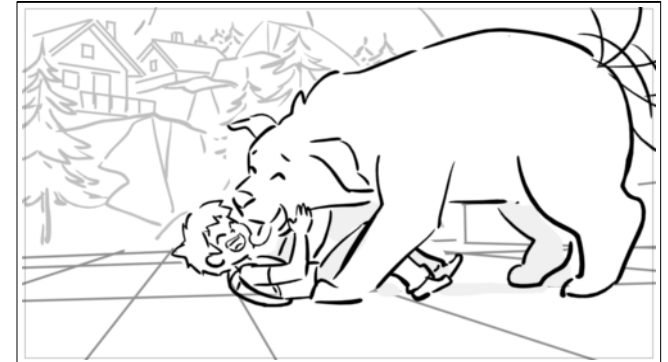

**Dialogue**  
10. SEBASTIEN (riant)  
Haha !

**Action Notes**  
Belle lèche le visage de SEB

Scene	Duration	Panel	Duration
020	03:07	2	01:07



**Dialogue**  
 10. SEBASTIEN (riant)  
 Ma Belle !

**Action Notes**  
 Adele IN

Scene	Duration	Panel	Duration
020	03:07	3	00:20



**Dialogue**  
 PU ADELE  
 Dis Sébastien?

Scene	Duration	Panel	Duration
021	03:21	1	01:00



**Dialogue**  
 PU ADELE (inquiète)  
 A quoi tu pensais quand tu parlais de faire quelque chose d'extraordinaire?

Scene	Duration	Panel	Duration
021	03:21	2	00:17

**Dialogue**

PU ADELE (inquiète)

A quoi tu pensais quand tu parlais de faire quelque chose d'extraordinaire?

Scene	Duration	Panel	Duration
021	03:21	3	02:04

**Dialogue**

PU ADELE (inquiète)

A quoi tu pensais quand tu parlais de faire quelque chose d'extraordinaire?

Scene	Duration	Panel	Duration
022	04:08	1	00:10

**Dialogue**

PU SÉBASTIEN (mystérieux)

Ha!Ha!



Scene	Duration	Panel	Duration
022	04:08	2	01:20



**Dialogue**

PU SÉBASTIEN (mystérieux)  
Ha!Ha!

Scene	Duration	Panel	Duration
022	04:08	3	00:21



**Dialogue**

12. SÉBASTIEN  
Tu te souviens du Pic Sans Nom ?

**Action Notes**

JB IN passe derrière SEB et BELLE

Scene	Duration	Panel	Duration
022	04:08	4	00:19

Scene	Duration	Panel	Duration
022	04:08	5	00:13



**Dialogue**

12. SÉBASTIEN  
 Tu te souviens du Pic Sans Nom ?

**Action Notes**

JB s'arrête net REAC

Scene	Duration	Panel	Duration
023	03:13	1	00:09



**Dialogue**  
 13. ADELE  
 L'histoire que le Vieux Paoli nous  
 avait racontée ?

Scene	Duration	Panel	Duration
023	03:13	2	02:01



**Dialogue**  
 13. ADELE  
 L'histoire que le Vieux Paoli nous  
 avait racontée ?

**Action Notes**  
 JB se tourne vers les enfants

Scene	Duration	Panel	Duration
023	03:13	3	01:03



**Dialogue**  
 13. ADELE  
 Tu crois qu'elle est vraie ?

Scene	Duration	Panel	Duration
024	02:08	1	00:08

Scene	Duration	Panel	Duration
024	02:08	2	00:09

Scene	Duration	Panel	Duration
024	02:08	3	00:16



**Dialogue**

15. JEAN-BAPTISTE (enjoué)  
 Bien sûr qu'elle est vraie !

**Dialogue**

15. JEAN-BAPTISTE (enjoué)  
 Bien sûr qu'elle est vraie !

Scene	Duration	Panel	Duration
024	02:08	4	01:00

**Dialogue**

15. JEAN-BAPTISTE (enjoué)  
Le Pic Sans Nom est une montagne...

Scene	Duration	Panel	Duration
025	04:05	1	00:09

**Dialogue**

15. JEAN-BAPTISTE (enjoué)  
dont on ne distingue que la base,

Scene	Duration	Panel	Duration
025	04:05	2	02:04

**Dialogue**

15. JEAN-BAPTISTE (enjoué)  
dont on ne distingue que la base,

Scene	Duration	Panel	Duration
025	04:05	3	01:17



**Dialogue**  
 15. JEAN-BAPTISTE (enjoué)  
 dont on ne distingue que la base,

Scene	Duration	Panel	Duration
025_A	04:13	1	02:03



Scene	Duration	Panel	Duration
025_A	04:13	2	02:10



Scene	Duration	Panel	Duration
026	10:10	1	01:20



**Dialogue**

15. JEAN-BAPTISTE (enjoué)  
A cause d'elle,

Scene	Duration	Panel	Duration
026	10:10	2	00:04



**Dialogue**

15. JEAN-BAPTISTE (enjoué)  
A cause d'elle,

Scene	Duration	Panel	Duration
026	10:10	3	02:04



**Dialogue**

15. JEAN-BAPTISTE (enjoué)  
aucun homme n'a pu y accéder.

Scene	Duration	Panel	Duration
026	10:10	4	02:15

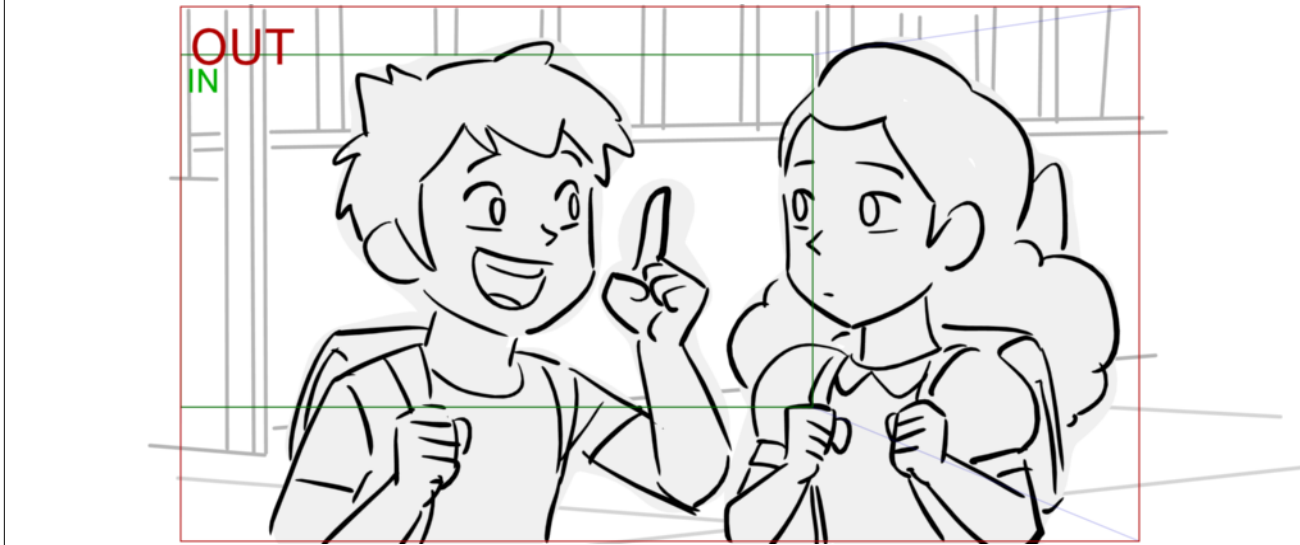
**Dialogue**

16. SÉBASTIEN

Il paraît que celui qui réussira à gagner le sommet

**Action Notes**

TRK OUT

Scene	Duration	Panel	Duration
026	10:10	5	02:02

**Dialogue**

16. SÉBASTIEN

aura le droit de lui donner son nom !



Scene	Duration	Panel	Duration
026	10:10	6	01:15

**Dialogue**

17. JEAN-BAPTISTE

C'est ce que la légende raconte...

Scene	Duration	Panel	Duration
027	07:11	1	03:11

**Dialogue**

17. JEAN-BAPTISTE

Mais cette brume est étrange...

**Action Notes**

SLOW PAN

Scene	Duration	Panel	Duration
027	07:11	2	01:09



NO PANEL

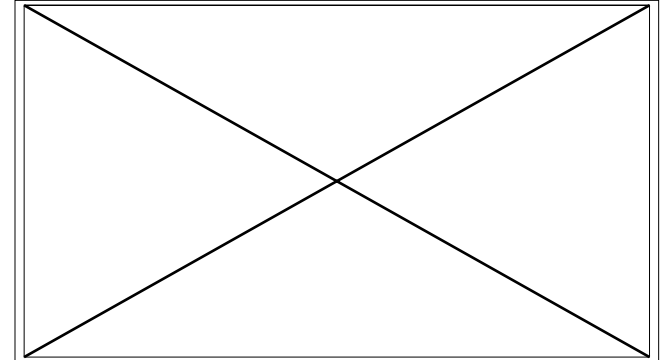

**Dialogue**

17. JEAN-BAPTISTE

A certains moments de l'année, elle peut se disperser.

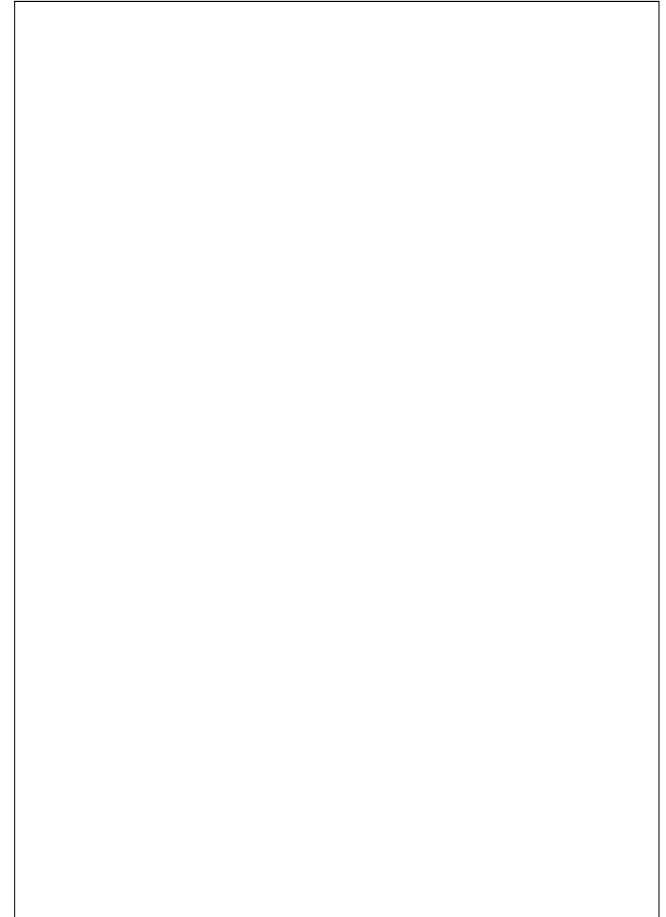

Scene	Duration	Panel	Duration
027	07:11	3	02:16

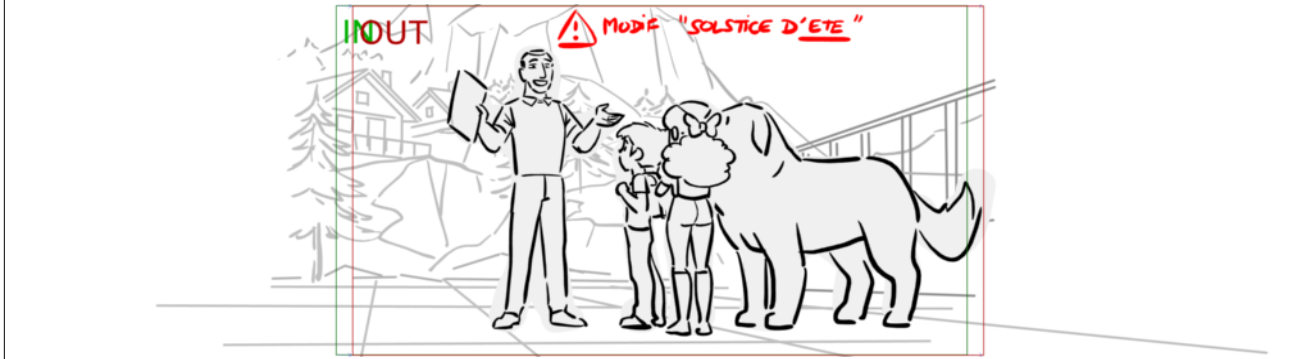
**Dialogue**

17. JEAN-BAPTISTE MODIF

Comme par exemple au matin du solstice d'été...

Scene	Duration	Panel	Duration
028	03:06	1	00:08

**Dialogue**

17. JEAN-BAPTISTE

Qui aura lieu?...

Scene	Duration	Panel	Duration
028	03:06	2	01:00

Scene	Duration	Panel	Duration
028	03:06	3	01:00

Scene	Duration	Panel	Duration
028	03:06	4	00:15



**Dialogue**  
 17. JEAN-BAPTISTE  
 Qui aura lieu?...

**Dialogue**  
 PU SEBASTIEN (regarde Belle géné)  
 Heuu...

**Dialogue**  
 18. ADELE(bonne élève)  
 Demain.

**Action Notes**  
 JB FAST IN

**Action Notes**  
 SEB rougit embarrassé

**Action Notes**  
 Adèle IN

Scene	Duration	Panel	Duration
028	03:06	5	00:08



**Dialogue**

18. ADELE (bonne élève)  
Demain.

Scene	Duration	Panel	Duration
029	01:11	1	00:03

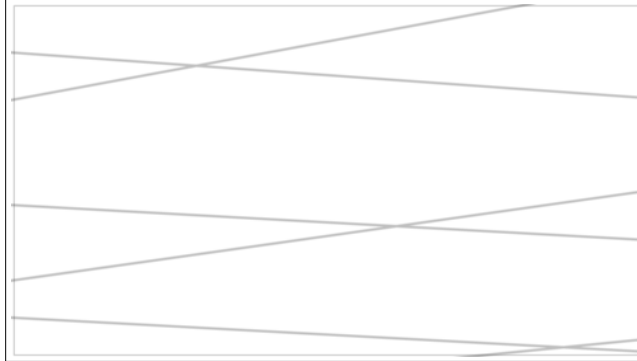

**Dialogue**

19. JEAN-BAPTISTE (fier de son élève)  
Exact.

Scene	Duration	Panel	Duration
029	01:11	2	00:08

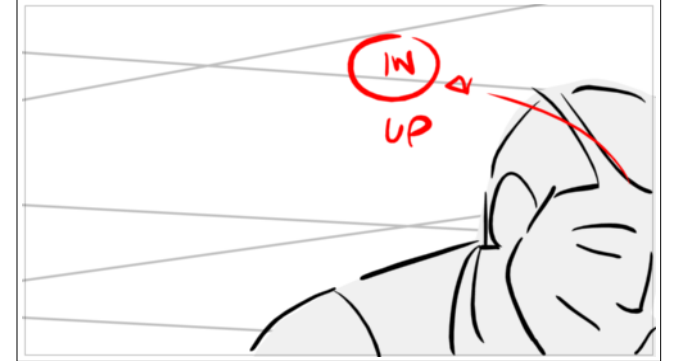

**Dialogue**

19. JEAN-BAPTISTE (fier de son élève)  
Exact.

Scene	Duration	Panel	Duration
029	01:11	3	01:00



**Dialogue**  
 19. JEAN-BAPTISTE (fier de son élève)  
 Exact.

Scene	Duration	Panel	Duration
030	05:14	1	01:14



**Dialogue**  
 19. JEAN-BAPTISTE  
 Tout à fait exact Adèle...

**Action Notes**  
 Adèle fière. SEB la regarde avec admiration

Scene	Duration	Panel	Duration
030	05:14	2	01:16



**Dialogue**  
 19. JEAN-BAPTISTE  
 Bon à bientôt les enfants !

**Action Notes**  
 JB OUT

Scene	Duration	Panel	Duration
030	05:14	3	00:09



**Dialogue**

19. JEAN-BAPTISTE  
Bon à bientôt les enfants !

Scene	Duration	Panel	Duration
030	05:14	4	01:00



**Dialogue**

20. SÉBASTIEN  
Tu te rends compte

Scene	Duration	Panel	Duration
030	05:14	5	00:13



**Dialogue**

20. SÉBASTIEN  
si j'y arrivais

Scene	Duration	Panel	Duration
030	05:14	6	00:12



Dialogue  
 20. SÉBASTIEN  
 si j'y arrivais

Scene	Duration	Panel	Duration
031	04:08	1	00:15

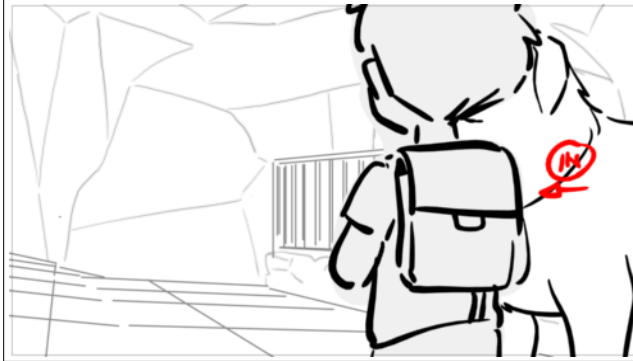

Scene	Duration	Panel	Duration
031	04:08	2	01:02





Scene	Duration	Panel	Duration
031	04:08	3	01:00

**Dialogue**

20. SÉBASTIEN

"Le Pic de Sébastien" !

Scene	Duration	Panel	Duration
031	04:08	4	01:04

**Dialogue**

20. SÉBASTIEN

Ce serait génial !

Scene	Duration	Panel	Duration
031	04:08	5	00:12

**Dialogue**

21. ADELE(raisonnable)

Euh... oui, mais

Scene	Duration	Panel	Duration
032	05:02	1	01:00

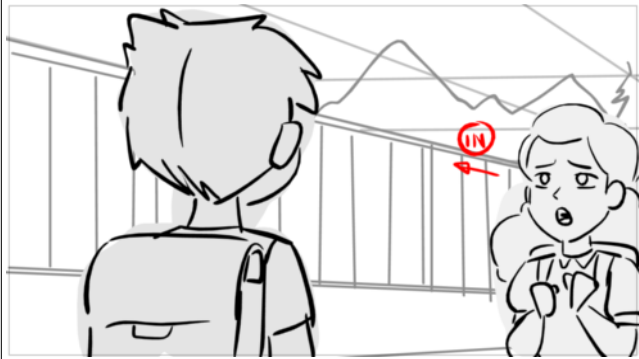
**Dialogue**

21. ADELE(raisonnable)  
ça doit être dangereux quand même

Scene	Duration	Panel	Duration
032	05:02	2	01:00

**Dialogue**

21. ADELE(raisonnable)  
ça doit être dangereux quand même

Scene	Duration	Panel	Duration
032	05:02	3	01:24

**Dialogue**

21. ADELE(raisonnable)  
vu que personne n'a jamais réussi.

Scene	Duration	Panel	Duration
032	05:02	4	01:03

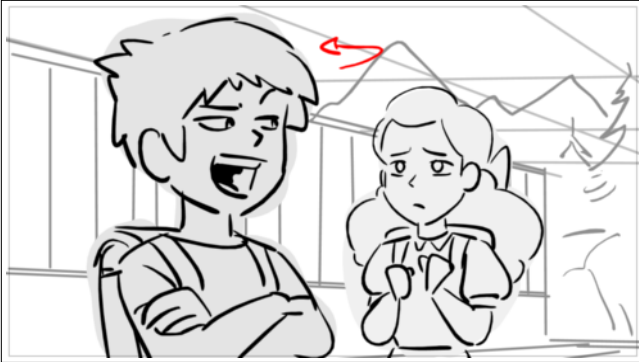

**Dialogue**

22. SÉBASTIEN (malicieux et plein d'entrain)  
Je suis pas personne

Scene	Duration	Panel	Duration
033	03:13	1	00:13

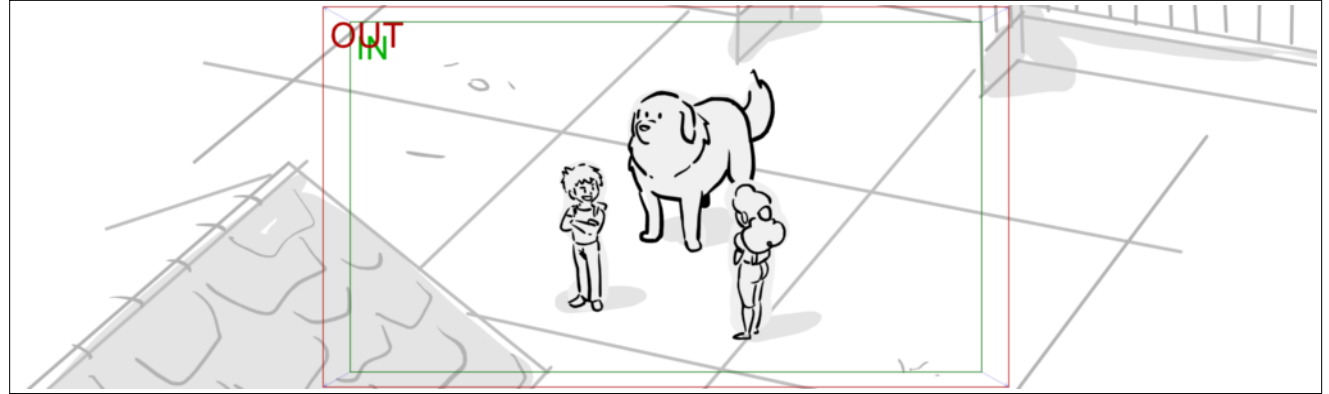

**Dialogue**

22. SÉBASTIEN (malicieux et plein d'entrain)  
je suis le Fils de la Montagne !

**Action Notes**

SLOW TRK OUT

Scene	Duration	Panel	Duration
033	03:13	2	00:24

NO PANEL

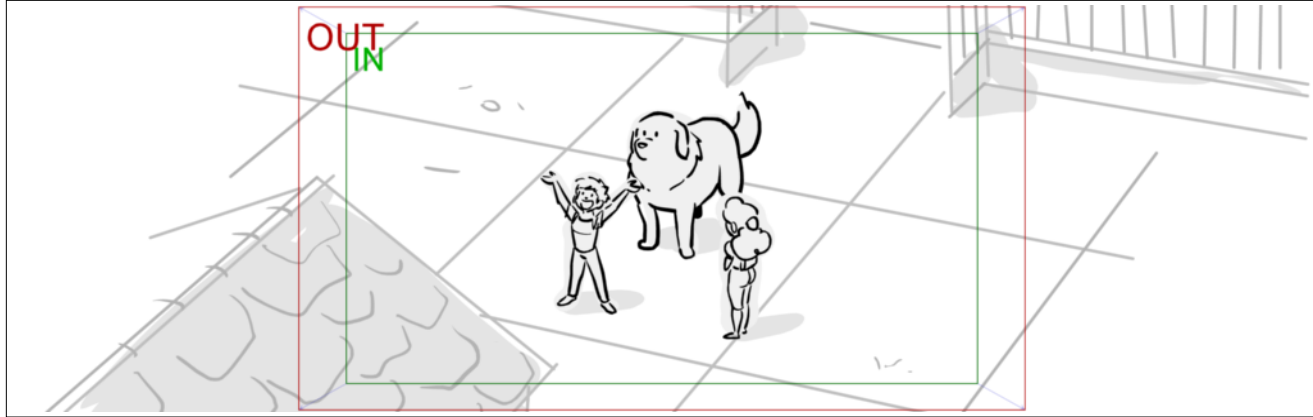

**Dialogue**

22. SÉBASTIEN (malicieux et plein d'entrain)  
je suis le Fils de la Montagne !

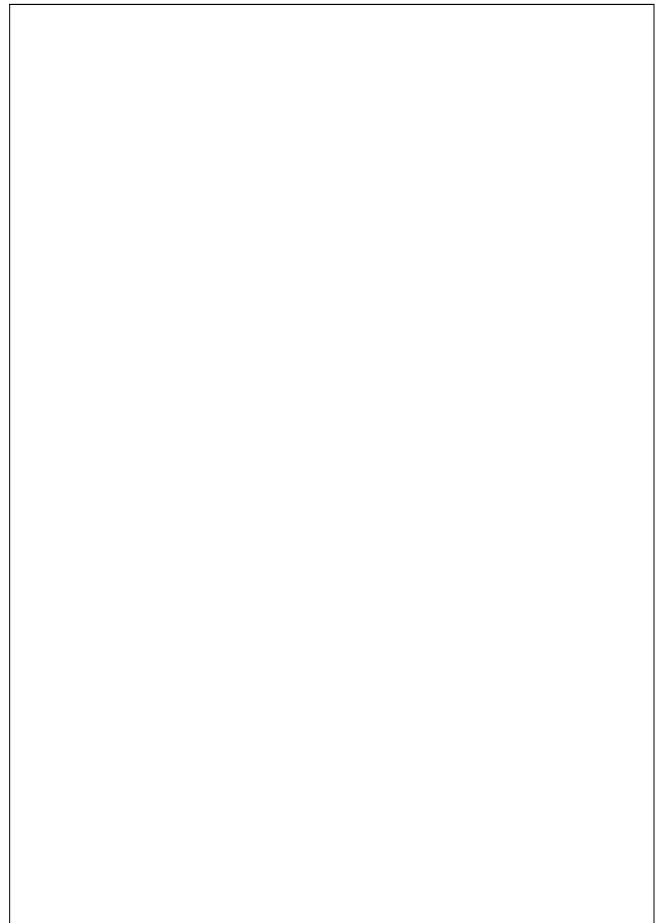
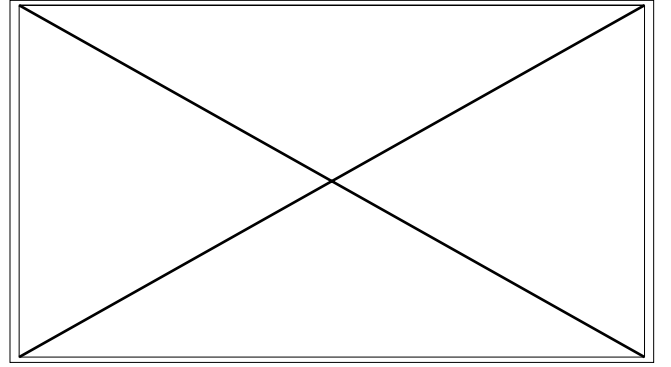

Scene	Duration	Panel	Duration
033	03:13	3	00:11

**Dialogue**

22. SÉBASTIEN (malicieux et plein d'entrain)  
je suis le Fils de la Montagne !

NO PANEL

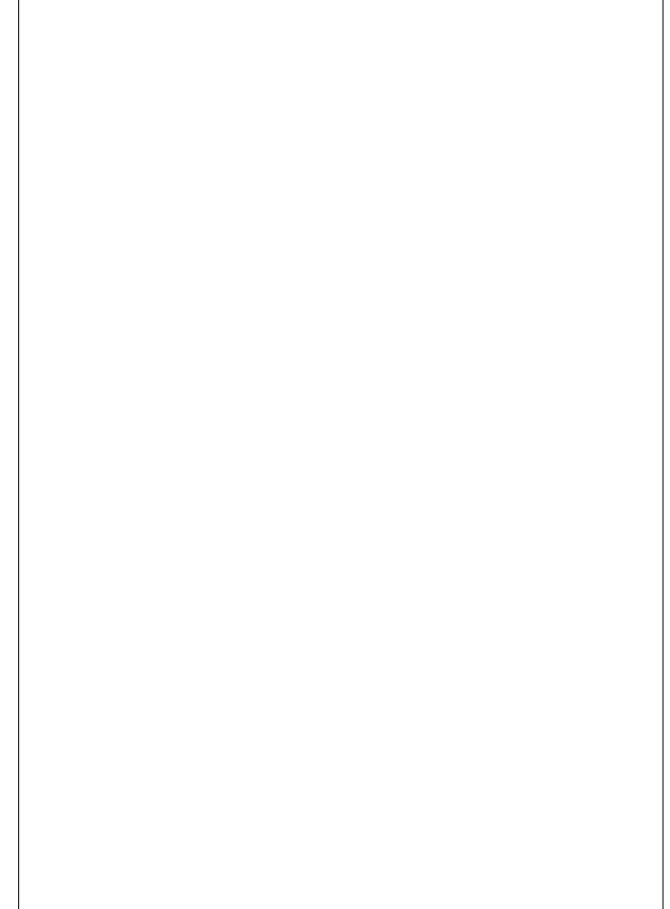
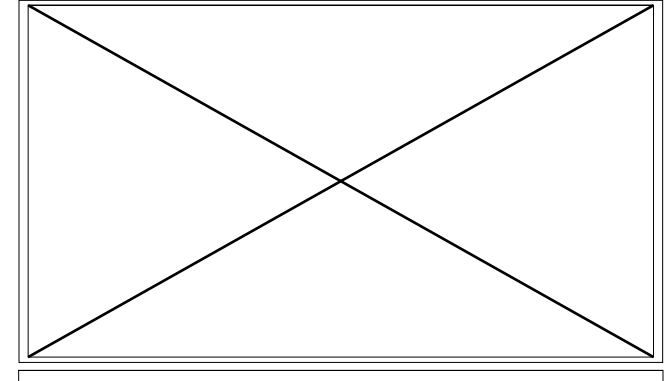



Scene	Duration	Panel	Duration
033	03:13	4	00:10

NO PANEL

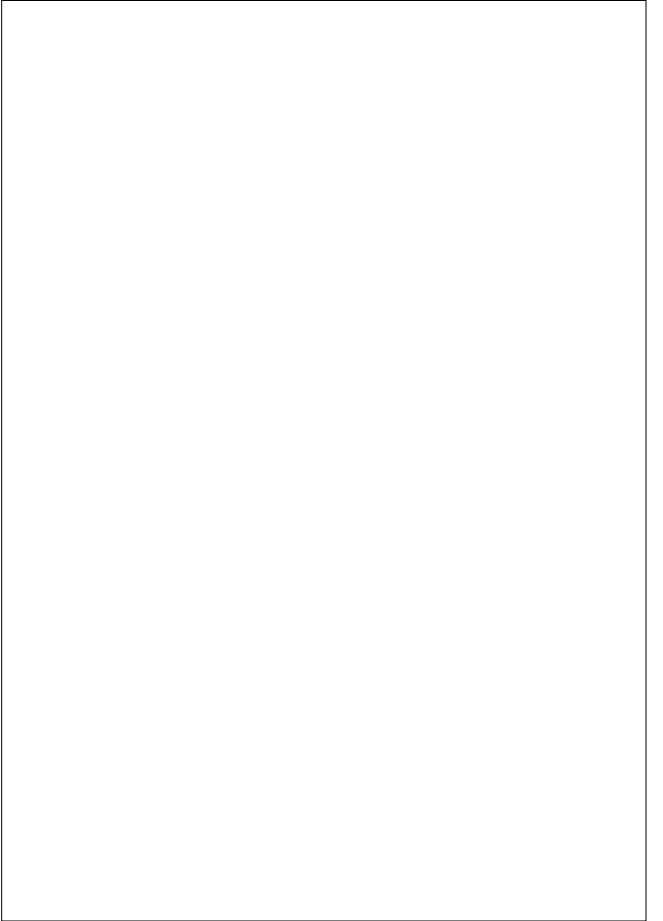
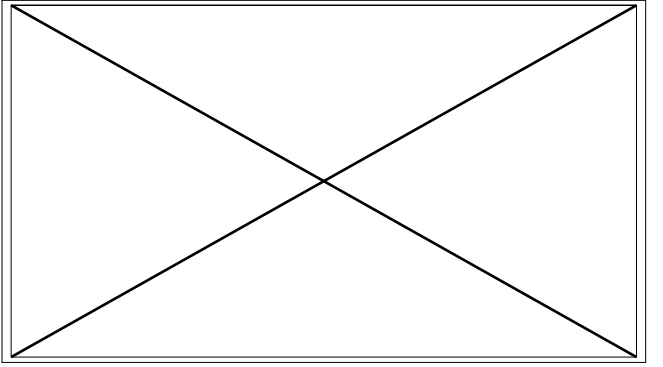
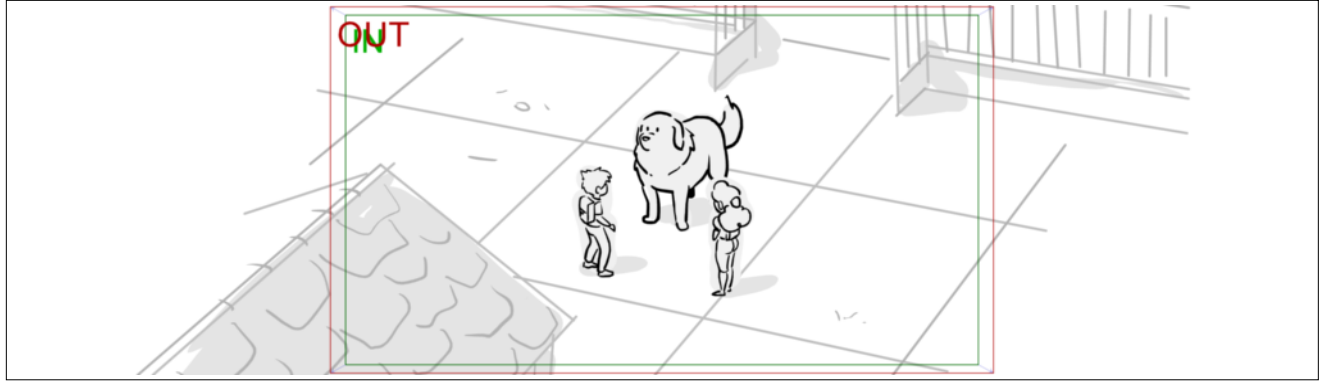

Scene	Duration	Panel	Duration
033	03:13	5	00:10

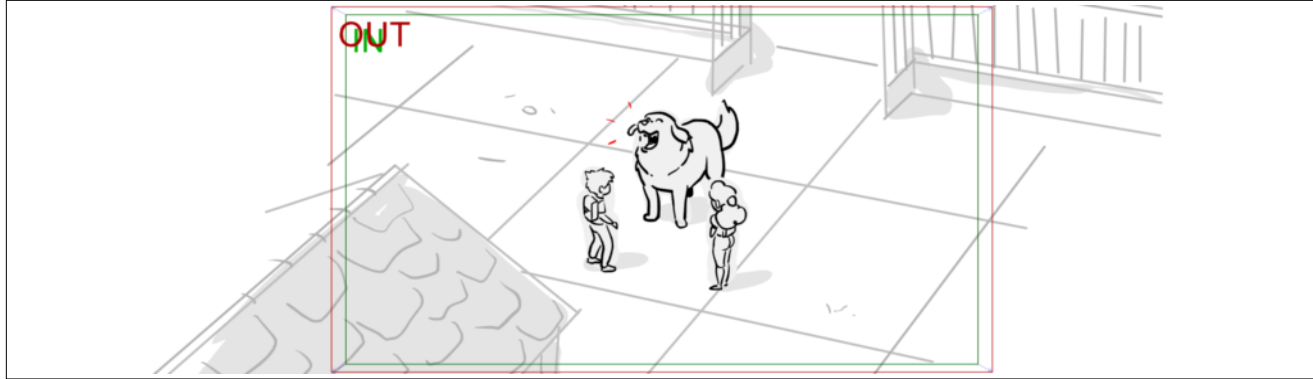

**Dialogue**  
 BELLE  
 WOUF !

Scene	Duration	Panel	Duration
033	03:13	6	00:20

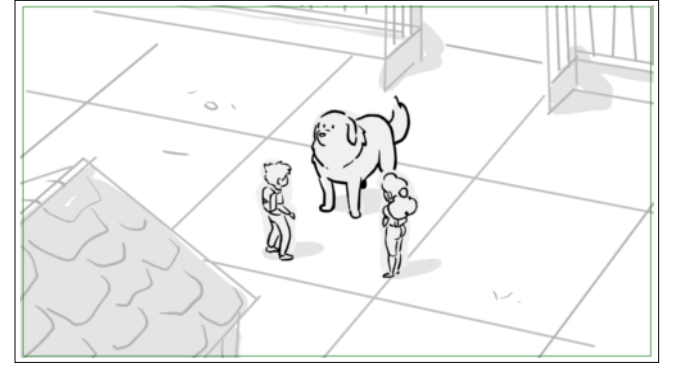



Scene	Duration	Panel	Duration
034	02:23	1	00:22

NO PANEL

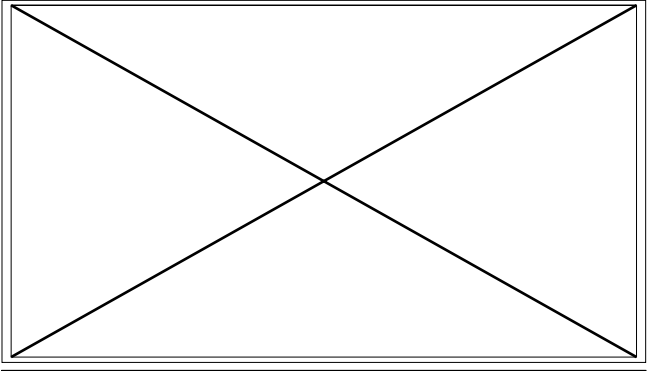
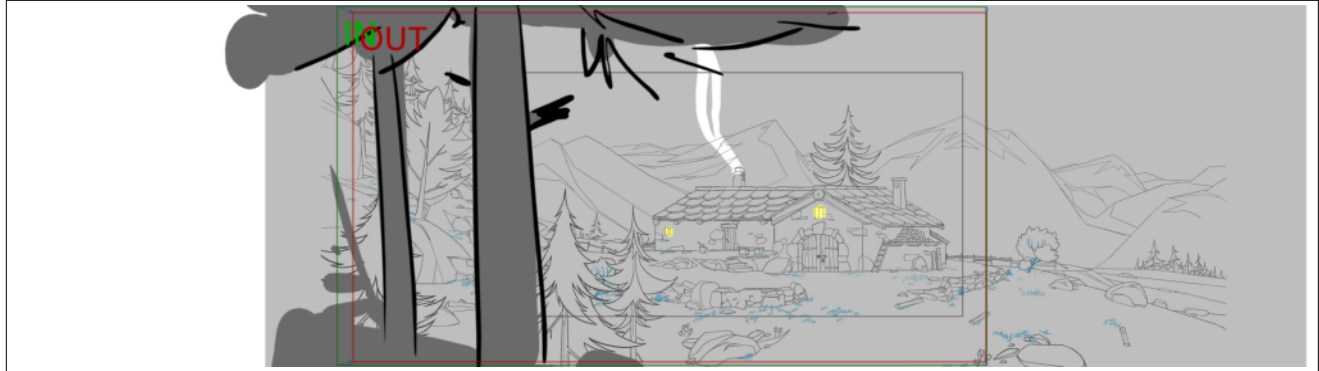

Action Notes

EXT BASTIDE NUIT

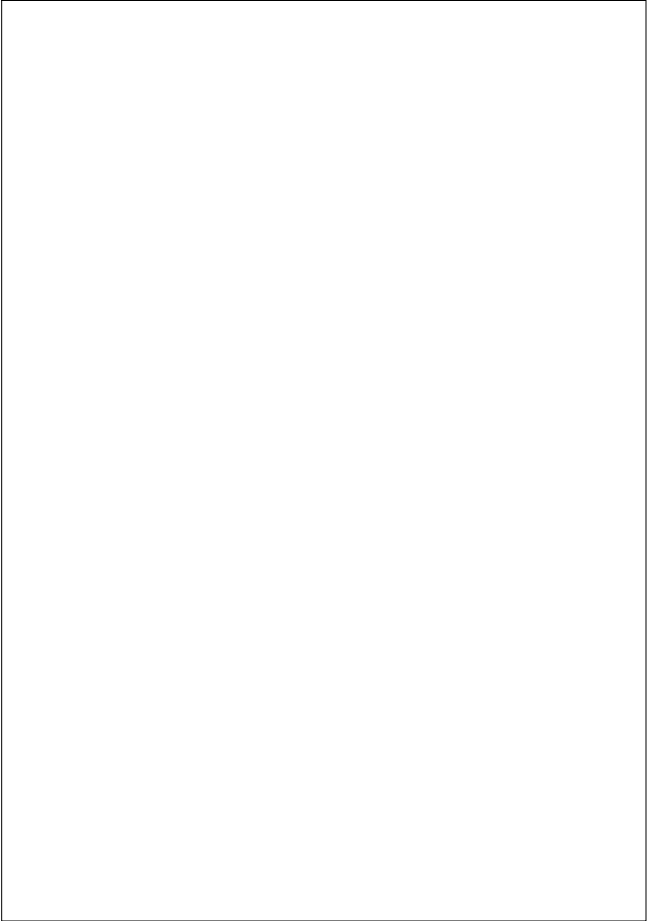





Scene	Duration	Panel	Duration
034	02:23	2	02:01

Scene	Duration	Panel	Duration
035	01:10	1	00:04

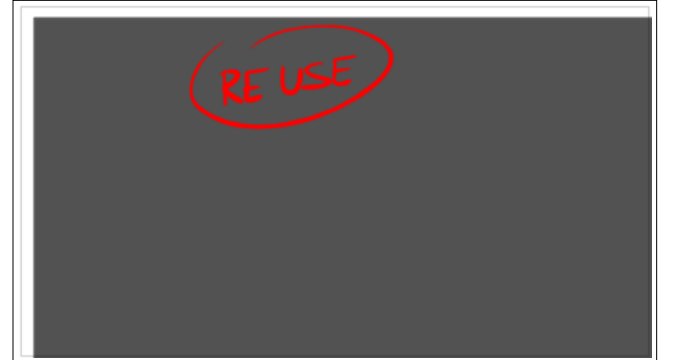
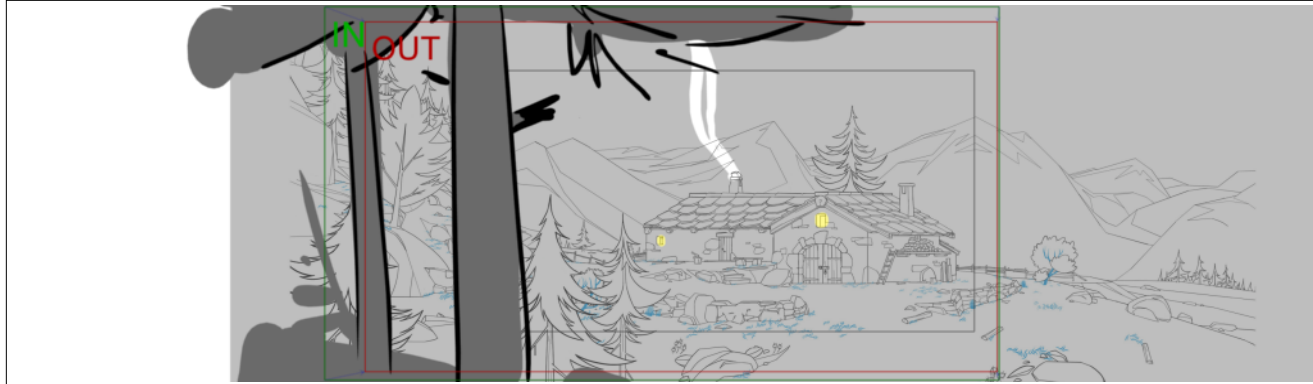

**Action Notes**

EXT BASTIDE NUIT

**Action Notes**

3. INT - BASTIDE, CHAMBRE SÉBASTIEN -  
NUIT

Scene	Duration	Panel	Duration
035	01:10	2	00:05



**Action Notes**

INT PLACARD REUT

Scene	Duration	Panel	Duration
035	01:10	3	00:12

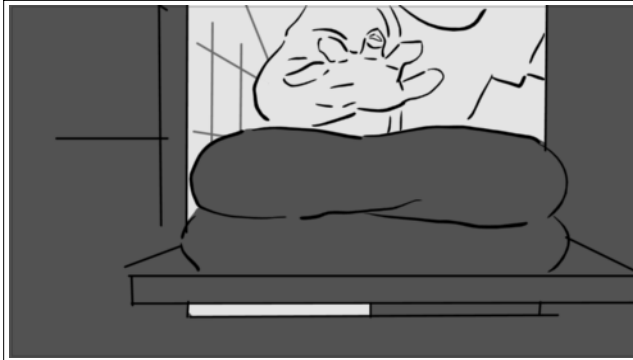

Scene	Duration	Panel	Duration
035	01:10	4	00:14



**Action Notes**

Main de SEB agrippe un pull

Scene	Duration	Panel	Duration
036	01:04	1	00:10



Scene	Duration	Panel	Duration
036	01:04	2	00:07

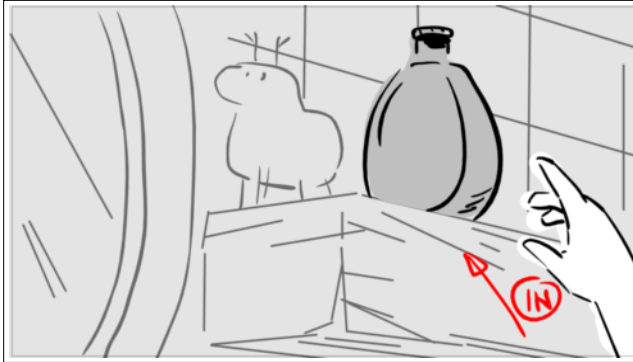

Scene	Duration	Panel	Duration
036	01:04	3	00:07



**Action Notes**

Main de SEB agrippe une gourde

Scene	Duration	Panel	Duration
036	01:04	4	00:05

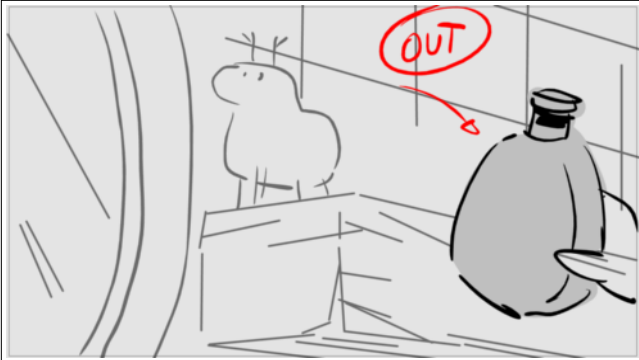

Scene	Duration	Panel	Duration
037	01:03	1	00:08



Scene	Duration	Panel	Duration
037	01:03	2	00:07



**Action Notes**

Main de SEB agrippe un bonnet



Scene	Duration	Panel	Duration
037	01:03	3	00:07

Scene	Duration	Panel	Duration
037	01:03	4	00:06

Scene	Duration	Panel	Duration
038	02:18	1	00:06

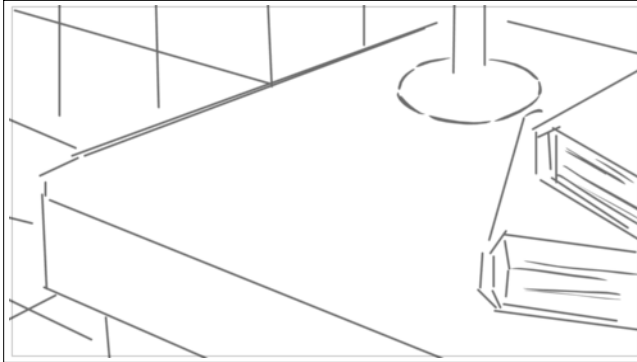

**Action Notes**  
INT BASTIDE SALLE A MANGER NUIT

Scene	Duration	Panel	Duration
038	02:18	2	00:10

Scene	Duration	Panel	Duration
038	02:18	3	00:12

Scene	Duration	Panel	Duration
038	02:18	4	00:17

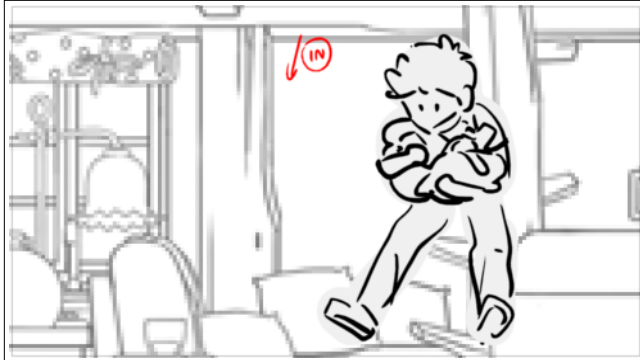

**Action Notes**

Sebastian jumps In from his bedroom les bras chargés

**Action Notes**

Sebastian Out



Scene	Duration	Panel	Duration
038	02:18	5	00:18



Scene	Duration	Panel	Duration
038	02:18	6	00:05



Scene	Duration	Panel	Duration
039	02:00	1	00:10



**Action Notes**

REUSE BG + ANIM CESAR

Scene	Duration	Panel	Duration
039	02:00	2	01:02

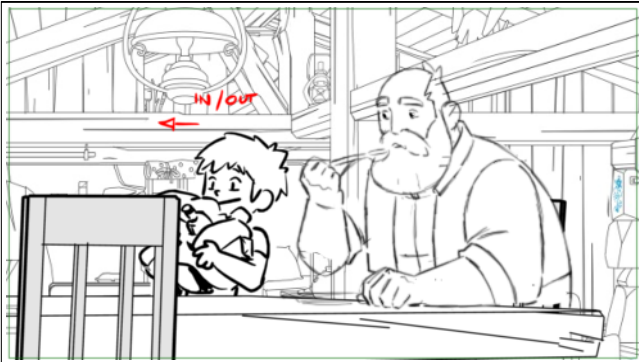

Scene	Duration	Panel	Duration
039	02:00	3	00:13



Scene	Duration	Panel	Duration
040	05:15	1	00:05



**Dialogue**

25. CÉSAR

(curieux) Qu'est-ce que vous faites ?



Scene	Duration	Panel	Duration
040	05:15	2	01:09



Scene	Duration	Panel	Duration
040	05:15	3	00:18

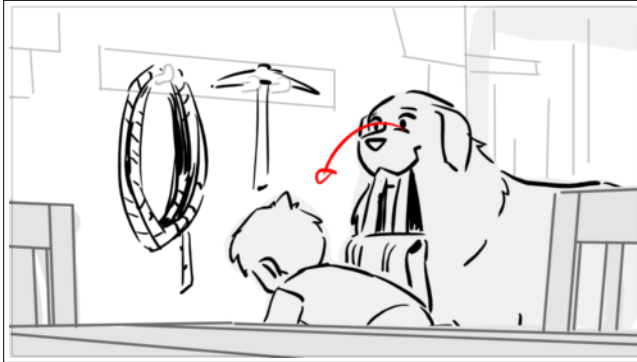

**Dialogue**

SFX Bruit des objets jetés au sol

**Action Notes**

SEB dépose son chargement par terre

Scene	Duration	Panel	Duration
040	05:15	4	00:19



**Dialogue**

25. CÉSAR  
(curieux) Qu'est-ce que vous faites ?

**Action Notes**

SEB agrippe la corde et le piolet

Scene	Duration	Panel	Duration
040	05:15	5	00:15



**Dialogue**  
 26. SÉBASTIEN MODIF  
 On se prépare

Scene	Duration	Panel	Duration
040	05:15	6	00:15



**Dialogue**  
 26. SÉBASTIEN MODIF  
 pour notre expédition de demain.

**Action Notes**  
 SEB Agrippe le sac que pore Belle

Scene	Duration	Panel	Duration
040	05:15	7	00:15



**Dialogue**  
 PU SÉBASTIEN  
 Hein Belle?

Scene	Duration	Panel	Duration
040	05:15	8	00:11

**Dialogue**

27. BELLE  
(confirme) Wouf !

Scene	Duration	Panel	Duration
040	05:15	9	00:08

**Dialogue**

PU SÉBASTIEN  
Hein Belle?

Scene	Duration	Panel	Duration
041	02:14	1	00:15

**Dialogue**

PU CÉSAR (amusé)  
Ah bon!

Scene	Duration	Panel	Duration
041	02:14	2	01:24



**Dialogue**  
 PU CÉSAR (amusé)  
 Et vous allez où?

Scene	Duration	Panel	Duration
042	02:21	1	01:18



**Dialogue**  
 26. SÉBASTIEN  
 On va s'attaquer au Pic Sans Nom !

**Action Notes**  
 ANGELINA sale une marmite  
 FX vapeur d'au

Scene	Duration	Panel	Duration
042	02:21	2	01:03



**Dialogue**  
 28. CÉSAR MODIF  
 Quoi?

**Action Notes**  
 REAC A+C  
 A lache la salière

Scene	Duration	Panel	Duration
043	01:20	1	00:03

Scene	Duration	Panel	Duration
043	01:20	2	00:03

Scene	Duration	Panel	Duration
043	01:20	3	00:03

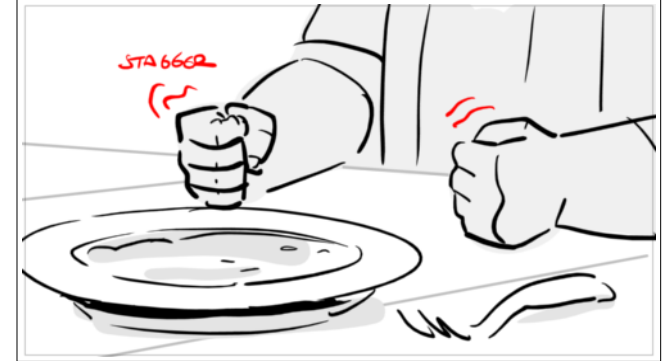
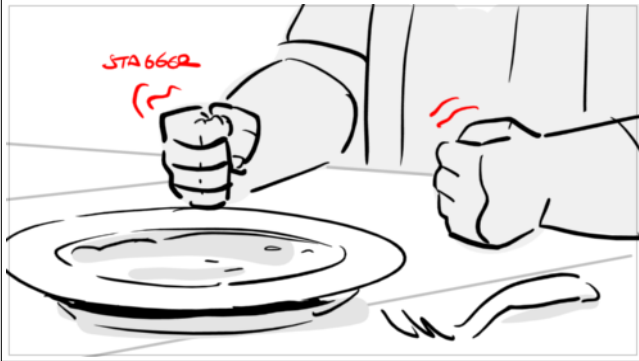

**Action Notes**

Les poings serrés de César tremblent de colère

Scene	Duration	Panel	Duration
043	01:20	4	00:03

Scene	Duration	Panel	Duration
043	01:20	5	00:06

Scene	Duration	Panel	Duration
043	01:20	6	00:06

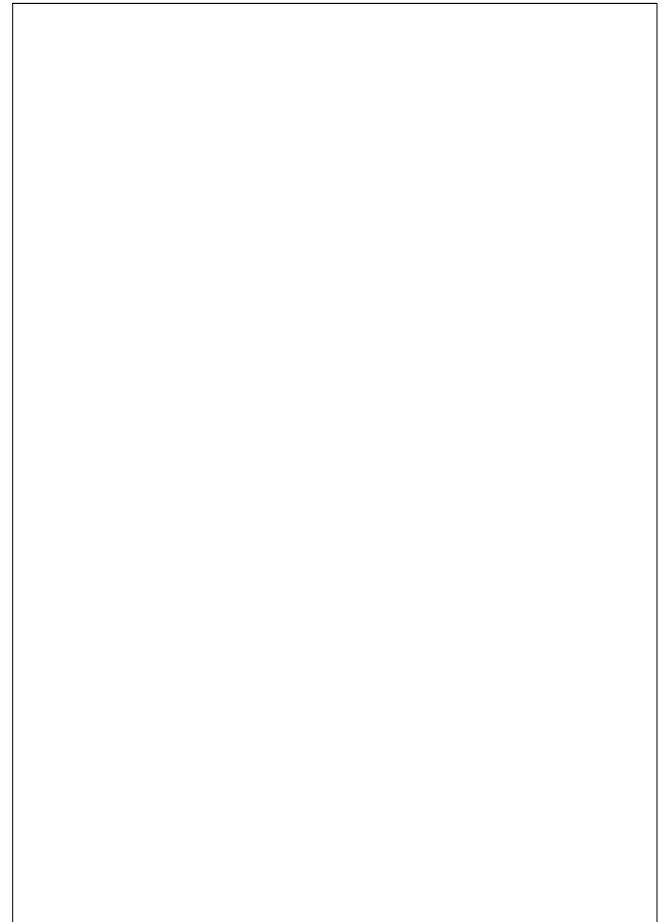
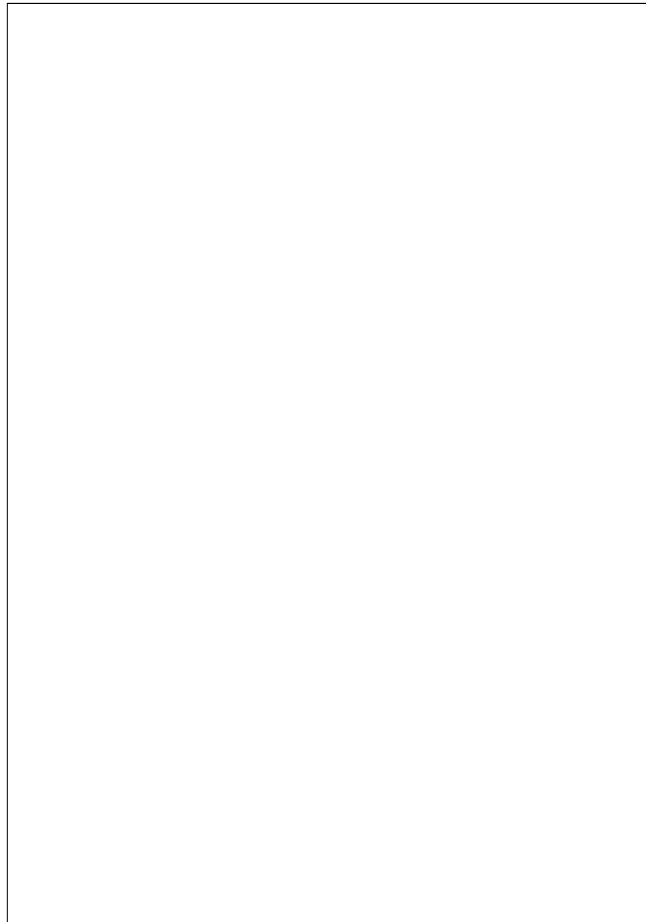
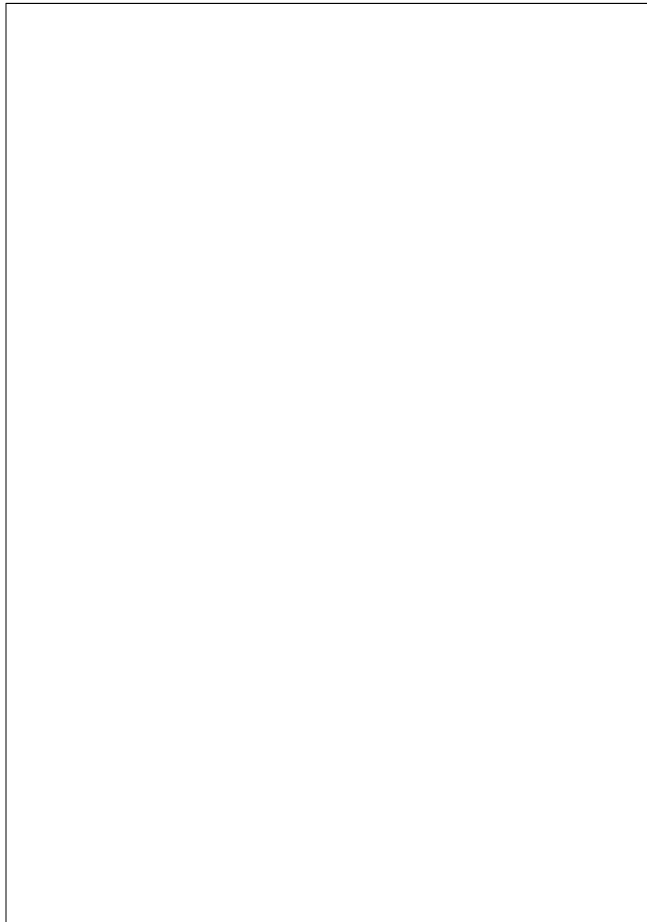
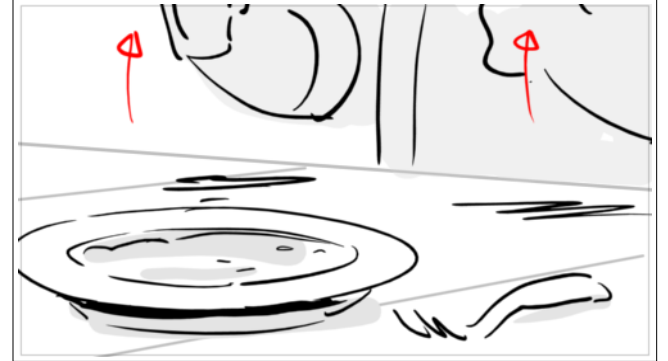
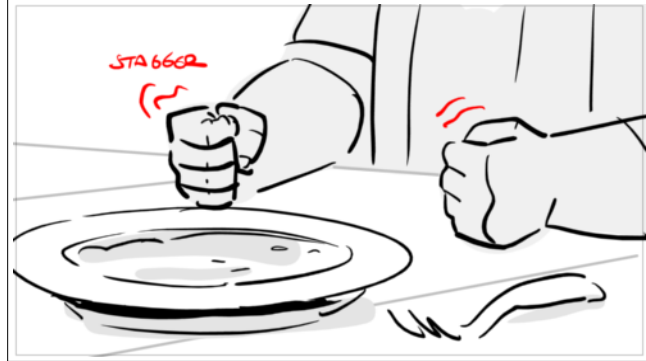
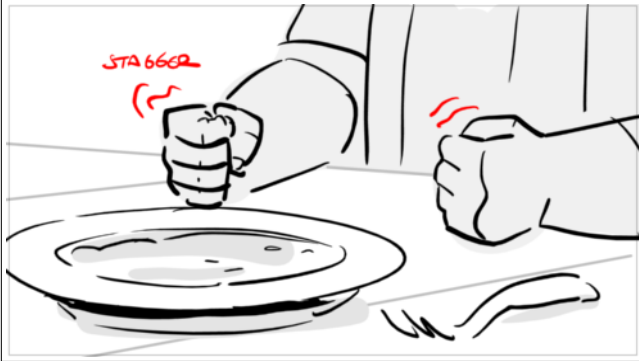

Scene	Duration	Panel	Duration
043	01:20	7	00:12



**Dialogue**  
 28. CÉSAR MODIF  
 Non!!

**Action Notes**  
 César tape sur la table  
 CAM SHAKE

Scene	Duration	Panel	Duration
043	01:20	8	00:09



Scene	Duration	Panel	Duration
044	01:21	1	00:07



**Dialogue**  
 32. CÉSAR  
 Je vous l'interdis!



Scene	Duration	Panel	Duration
044	01:21	2	00:07

NO PANEL

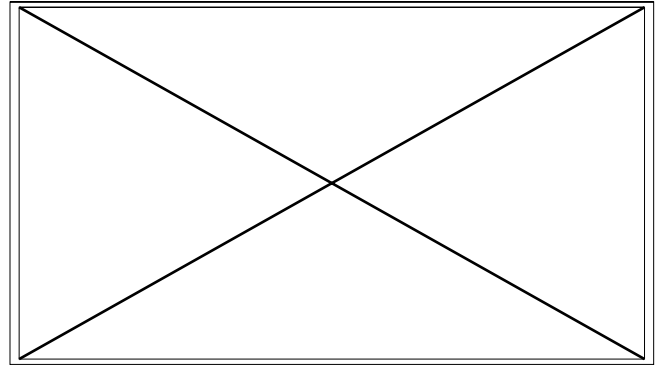

**Dialogue**  
32. CÉSAR  
Je vous l'interdis!

**Action Notes**  
PAN UP FOLLOW CESAR UP

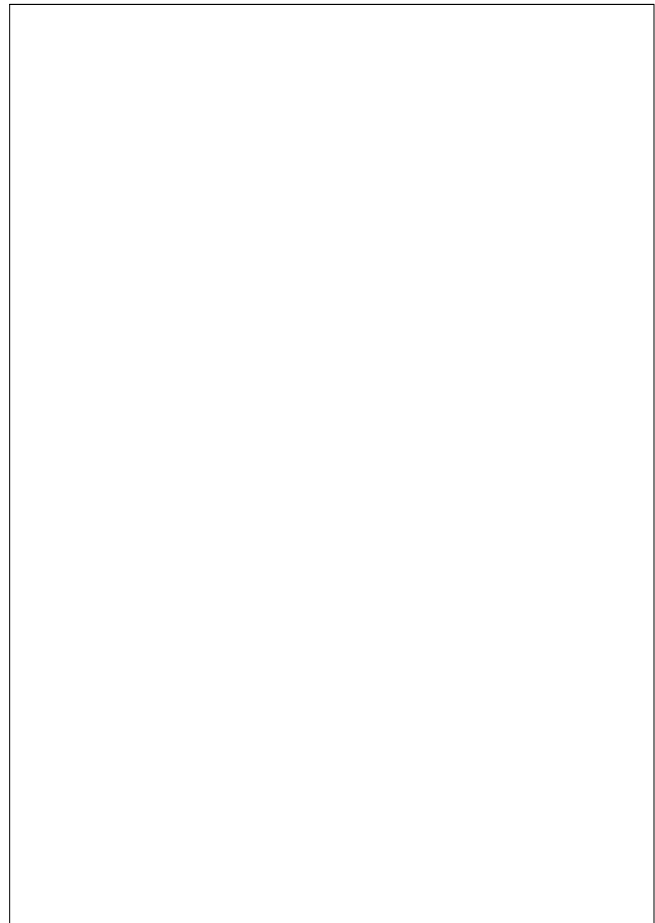



Scene	Duration	Panel	Duration
044	01:21	3	00:18



**Dialogue**  
 32. CÉSAR  
 Je vous l'interdis!

Scene	Duration	Panel	Duration
044	01:21	4	00:14



**Dialogue**  
 32. CÉSAR  
 Je vous l'interdis!

Scene	Duration	Panel	Duration
045	01:14	1	00:11



**Action Notes**  
SEB perplexe

Scene	Duration	Panel	Duration
045	01:14	2	01:03



**Dialogue**  
31. SÉBASTIEN (très surpris)  
Bah ?

Scene	Duration	Panel	Duration
046	04:22	1	00:06

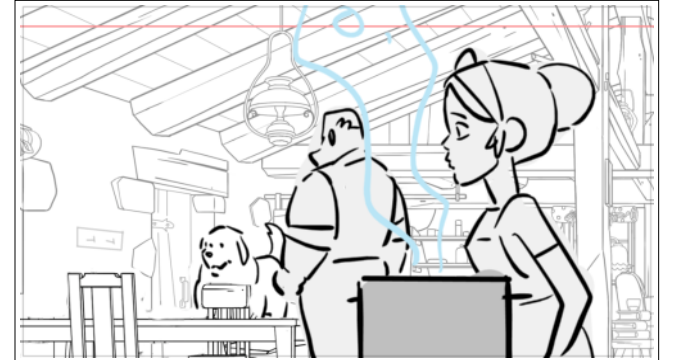

Scene	Duration	Panel	Duration
046	04:22	2	00:20

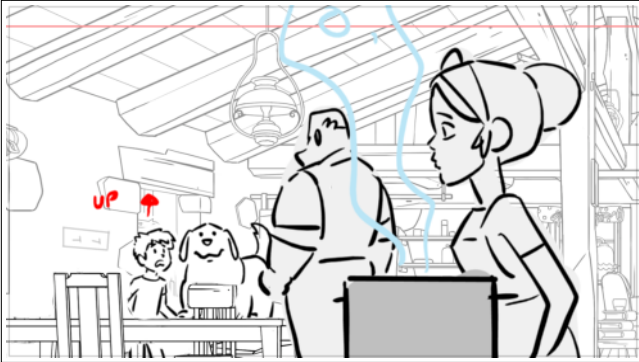

**Dialogue**

31. SÉBASTIEN (très surpris)  
Pourquoi on pourrait pas aller...

**Action Notes**

SEB IN UP

Scene	Duration	Panel	Duration
046	04:22	3	00:22

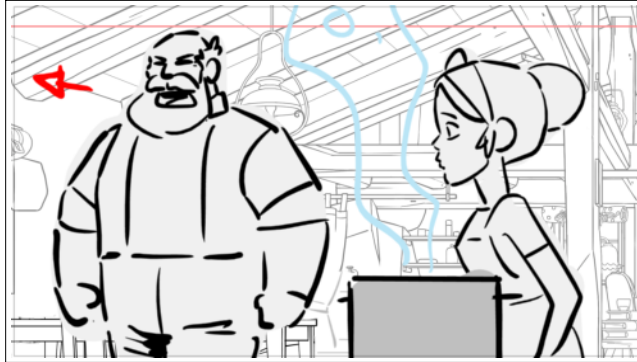

**Dialogue**

32. CÉSAR (l'interrompt)  
J'ai dit non ! Fin de la discussion.

Scene	Duration	Panel	Duration
046	04:22	4	01:15

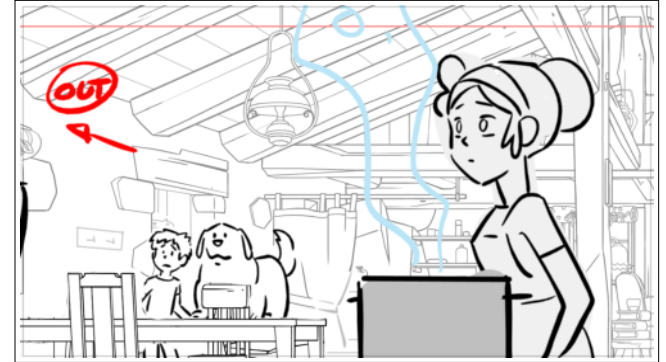

**Dialogue**

32. CÉSAR (l'interrompt)  
J'ai dit non ! Fin de la discussion.

Scene	Duration	Panel	Duration
046	04:22	5	00:19

Scene	Duration	Panel	Duration
046	04:22	6	00:08

Scene	Duration	Panel	Duration
046	04:22	7	00:07

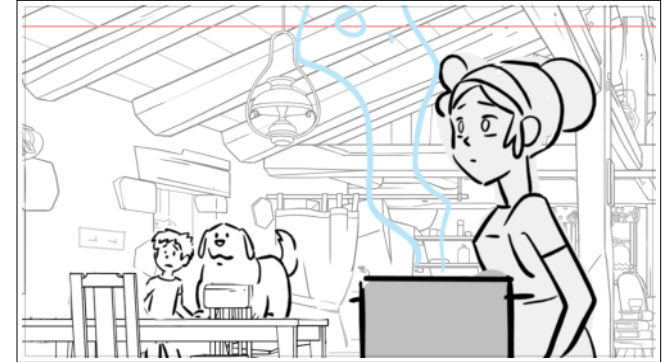
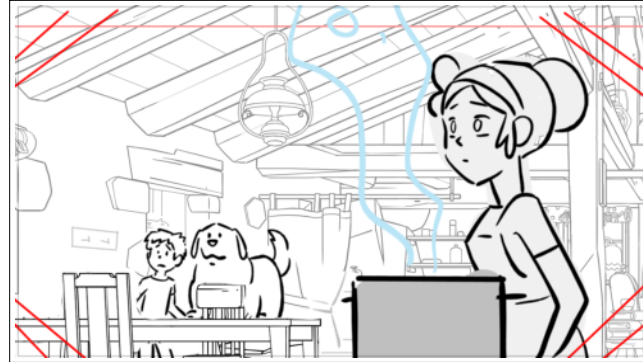
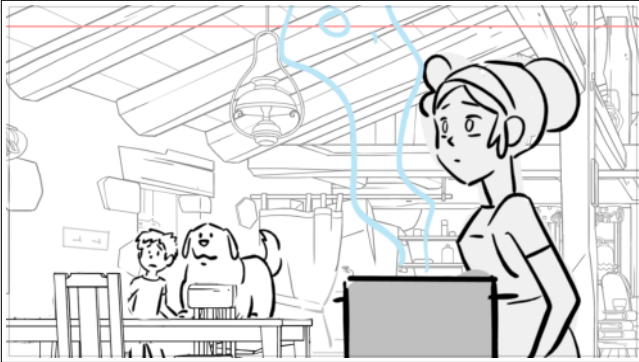

**Dialogue**  
SFX PORTE OFF

**Action Notes**  
CESAR claque la porte de sa chambre OS  
CAM SHAKE

Scene	Duration	Panel	Duration
047	02:21	1	00:14

Scene	Duration	Panel	Duration
047	02:21	2	00:06

Scene	Duration	Panel	Duration
047	02:21	3	00:10

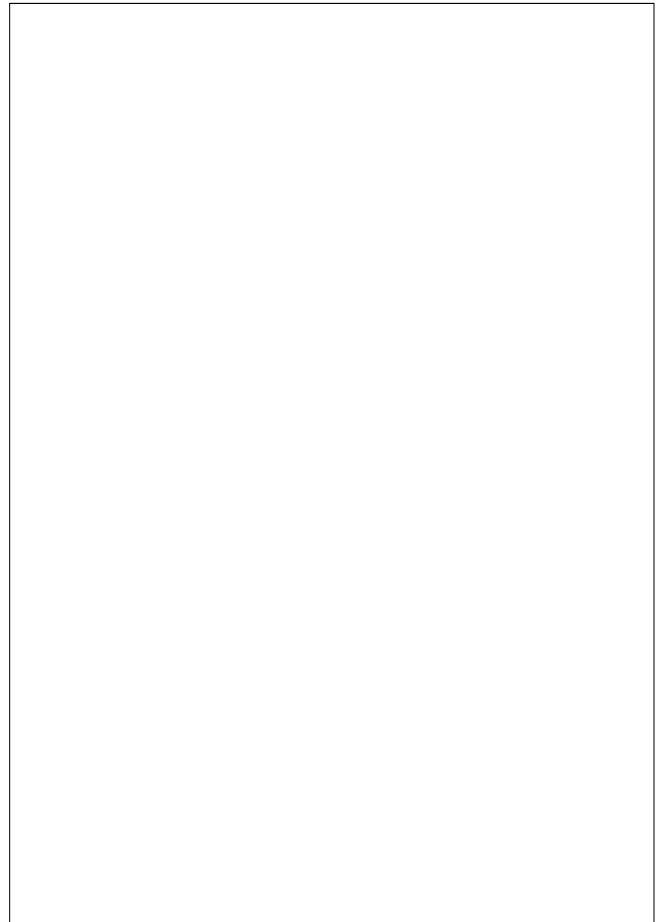
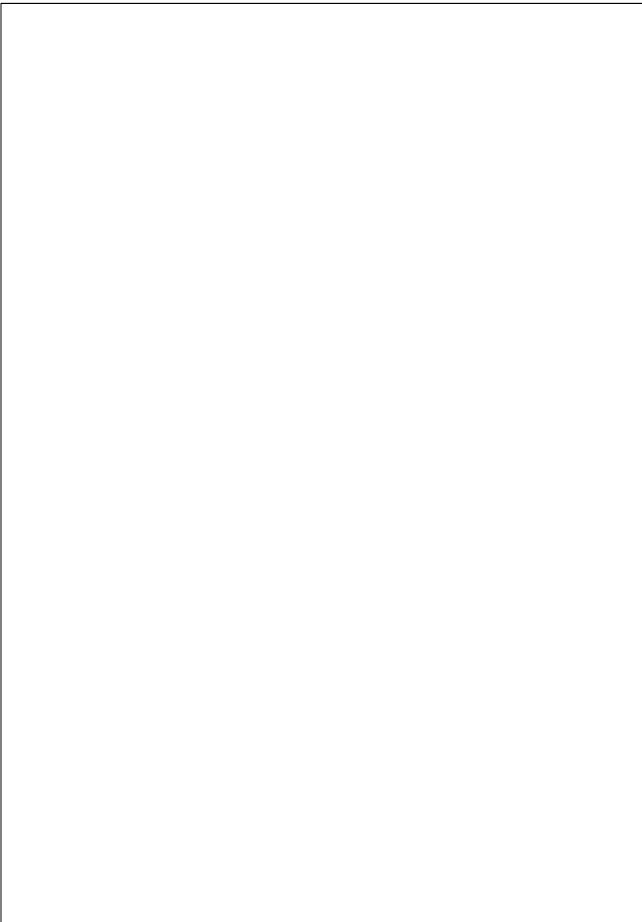

Scene	Duration	Panel	Duration
047	02:21	4	01:16

**Dialogue**

33. SÉBASTIEN MODIF

Nan mais qu'est-ce qu'il lui prend tout à coup ?

Scene	Duration	Panel	Duration
048	03:08	1	00:07



Scene	Duration	Panel	Duration
048	03:08	2	02:07

**Dialogue**

33. SÉBASTIEN MODIF

C'est pas la première fois qu'on part en expédition !

Scene	Duration	Panel	Duration
048	03:08	3	00:10



**Dialogue**  
 27. BELLE  
 (confirme) Wouf !

Scene	Duration	Panel	Duration
048	03:08	4	00:09



Scene	Duration	Panel	Duration
048_A_0	02:00	1	01:00

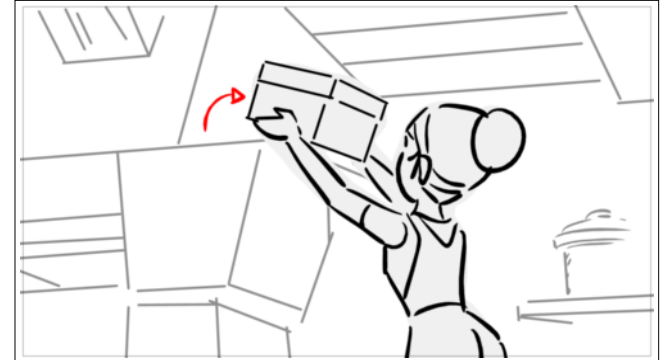

**Action Notes**  
 ANG attrappe une boîte au dessus de la chaminée

Scene	Duration	Panel	Duration
048_A_0	02:00	2	01:00

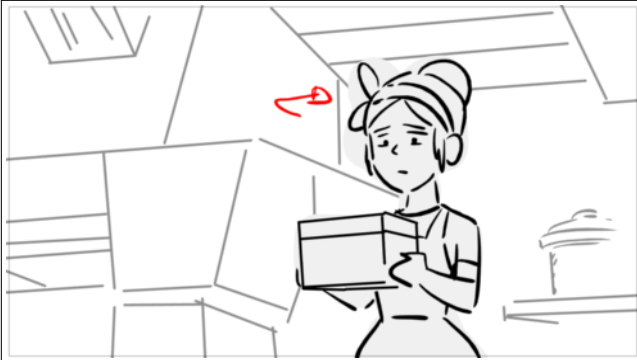

Scene	Duration	Panel	Duration
048_A	01:21	1	01:03

**Dialogue**

34. ANGELINA

Il faut le comprendre Sébastien.

Scene	Duration	Panel	Duration
048_A	01:21	2	00:18

**Dialogue**

34. ANGELINA

Il faut le comprendre Sébastien.



Scene	Duration	Panel	Duration
049	02:04	1	00:10

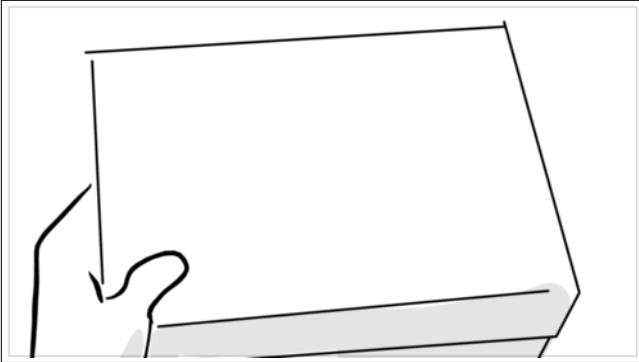

Scene	Duration	Panel	Duration
049	02:04	2	00:14



Scene	Duration	Panel	Duration
049	02:04	3	00:14

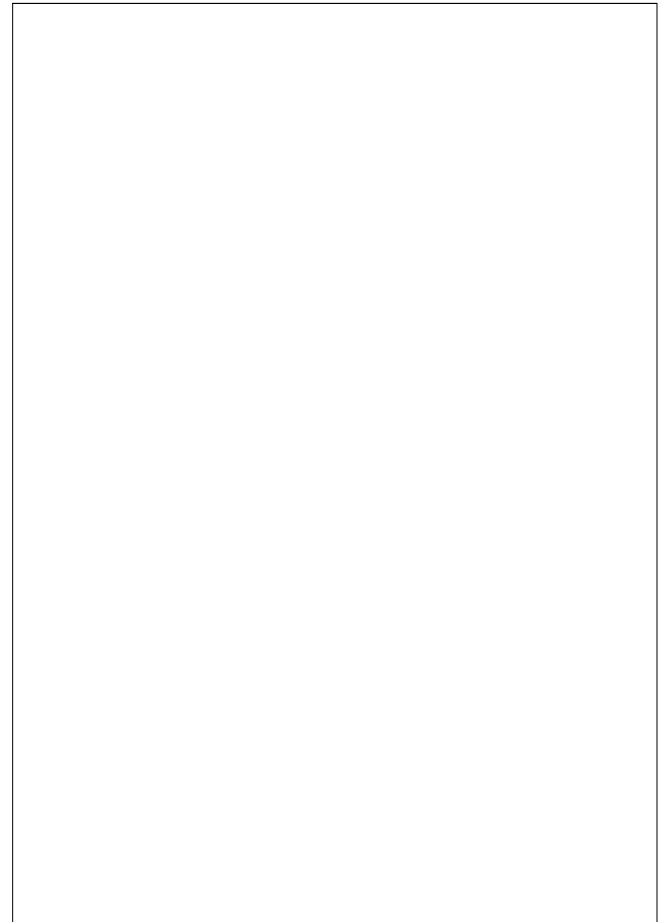
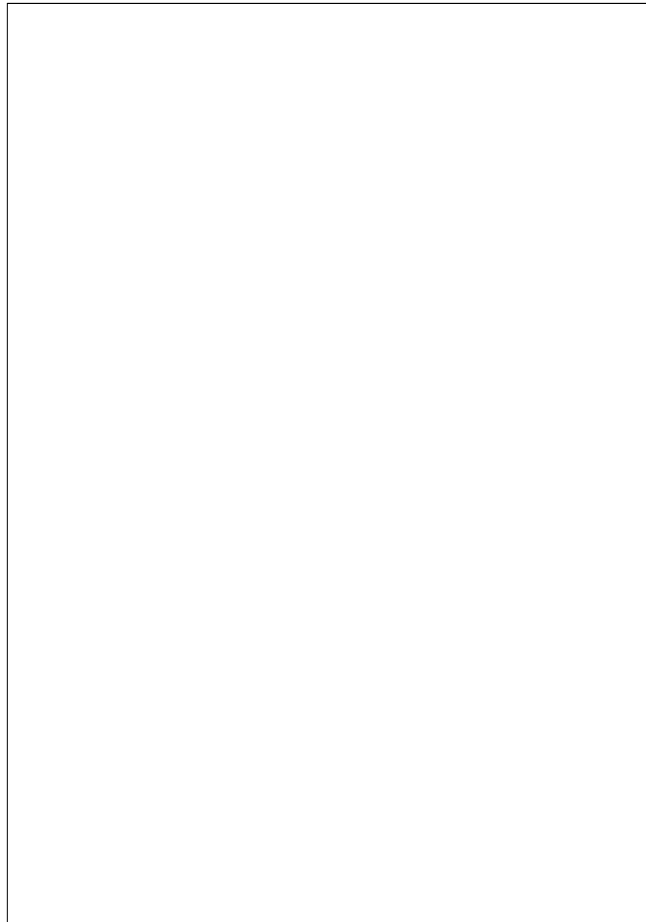
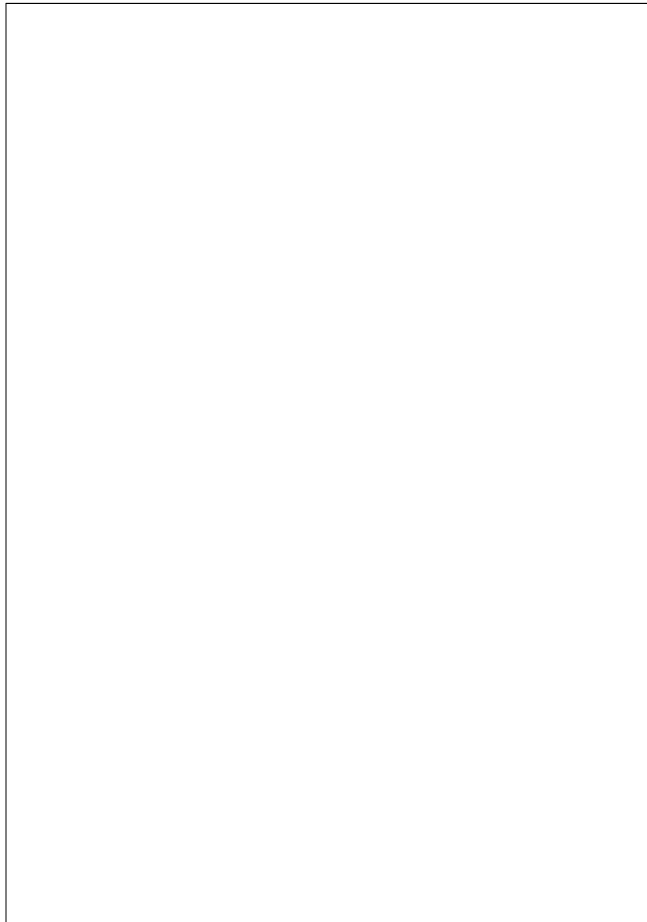

Scene	Duration	Panel	Duration
049	02:04	4	00:16



**Dialogue**

34. ANGELINA  
César a eu...

**Action Notes**

Main d'ANG IN saisit une photo de César et Nino

Scene	Duration	Panel	Duration
050	01:16	1	00:07



Scene	Duration	Panel	Duration
050	01:16	2	01:05



**Dialogue**

34. ANGELINA  
...une terrible expérience avec ce pic dans le passé...

Scene	Duration	Panel	Duration
050	01:16	3	00:04

**Dialogue**

34. ANGELINA

...une terrible expérience avec ce pic dans le passé...

Scene	Duration	Panel	Duration
051	05:08	1	00:08



Scene	Duration	Panel	Duration
051	05:08	2	01:10

**Dialogue**

35. SÉBASTIEN (intrigué)

Une terrible expérience ?

Scene	Duration	Panel	Duration
051	05:08	3	00:12



**Dialogue**

35. SÉBASTIEN (intrigué)  
Une terrible expérience ?

Scene	Duration	Panel	Duration
051	05:08	4	01:07



**Dialogue**

36. ANGELINA  
Quand il était plus jeune,

Scene	Duration	Panel	Duration
051	05:08	5	01:00



**Dialogue**

36. ANGELINA  
lui aussi a tenté d'atteindre le  
sommet du Pic Sans Nom.

**Action Notes**

ANG donne la photo à SEB

Scene	Duration	Panel	Duration
051	05:08	6	00:21



**Dialogue**

36. ANGELINA  
 . Avec son meilleur ami, Nino...

Scene	Duration	Panel	Duration
052	03:06	1	02:00

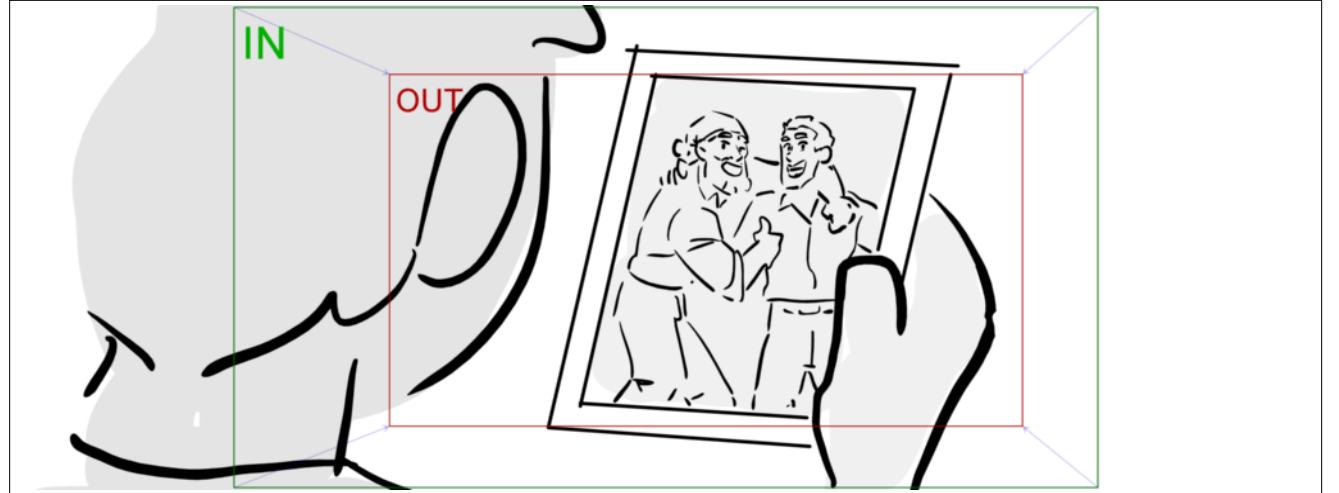

**Dialogue**

37. ANGELINA OFF  
 mais... ça ne s'est pas du tout passé comme prévu...

**Action Notes**

TRK IN

Scene	Duration	Panel	Duration
052	03:06	2	01:06



Dissolve	Duration
	00:12

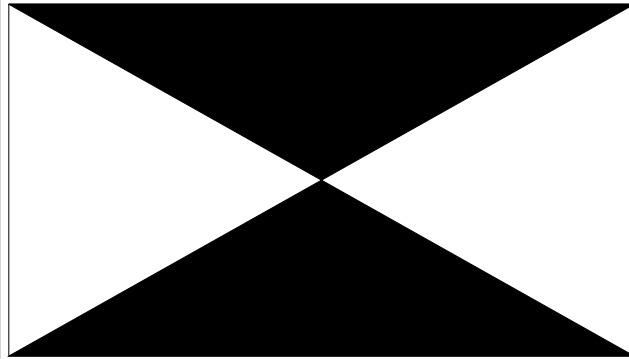

Scene	Duration	Panel	Duration
053	03:14	1	03:14

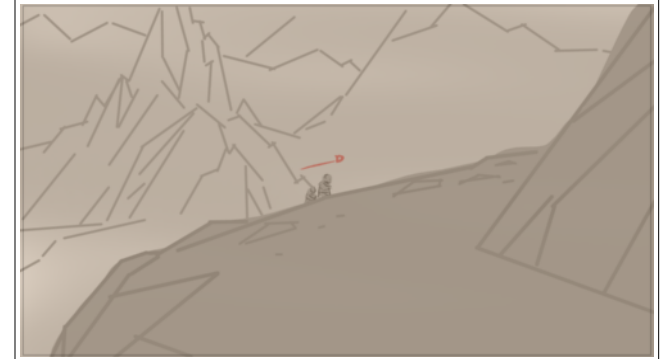

**Dialogue**

38. ANGELINA (OFF)  
Rapidement, l'ascension est devenue impossible. Ils ne voyaient pas à plus deux mètres.

**Action Notes**

5. EXT - PIC SANS NOM, HAUTE ALTITUDE - JOUR  
FLASHBACK (en Sépia).  
FX BRUME  
Nino et Cesar jeunes avancent

Scene	Duration	Panel	Duration
054	05:03	1	01:21



**Action Notes**

PAN BG  
FX BRUME

Scene	Duration	Panel	Duration
054	05:03	2	01:17



**Dialogue**

39. ANGELINA (OFF)  
César a insisté pour faire demi-tour  
mais Nino ne l'a pas écouté et s'est  
engouffré dans l'épaisse brume en  
direction du sommet.

**Action Notes**

CESAR arrête Nino  
STOP BG

Scene	Duration	Panel	Duration
054	05:03	3	00:09



**Dialogue**

39. ANGELINA (OFF)  
César a insisté pour faire demi-tour  
mais Nino ne l'a pas écouté et s'est  
engouffré dans l'épaisse brume en  
direction du sommet.

**Action Notes**

Nino se dégage

Scene	Duration	Panel	Duration
054	05:03	4	00:12



**Dialogue**

39. ANGELINA (OFF)

César a insisté pour faire demi-tour mais Nino ne l'a pas écouté et s'est engouffré dans l'épaisse brume en direction du sommet.

**Action Notes**

puis OUT

Scene	Duration	Panel	Duration
054	05:03	5	00:19



**Dialogue**

39. ANGELINA (OFF)

César a insisté pour faire demi-tour mais Nino ne l'a pas écouté et s'est engouffré dans l'épaisse brume en direction du sommet.

**Action Notes**

Cesar avance d'unpas et tend la main vers lui

Scene	Duration	Panel	Duration
055	03:04	1	01:03



**Action Notes**

Nino disparaît dans la brume



Scene	Duration	Panel	Duration
055	03:04	2	01:06



Scene	Duration	Panel	Duration
055	03:04	3	00:20

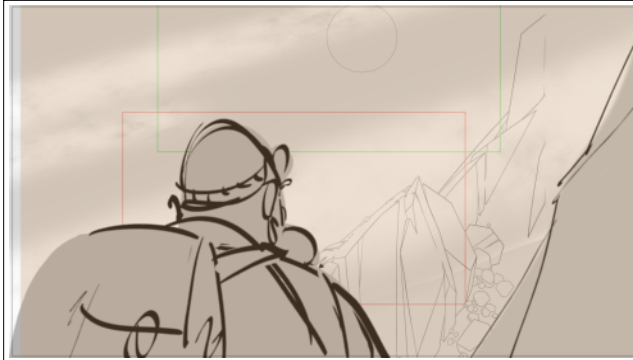

Scene	Duration	Panel	Duration
056	03:17	1	00:11

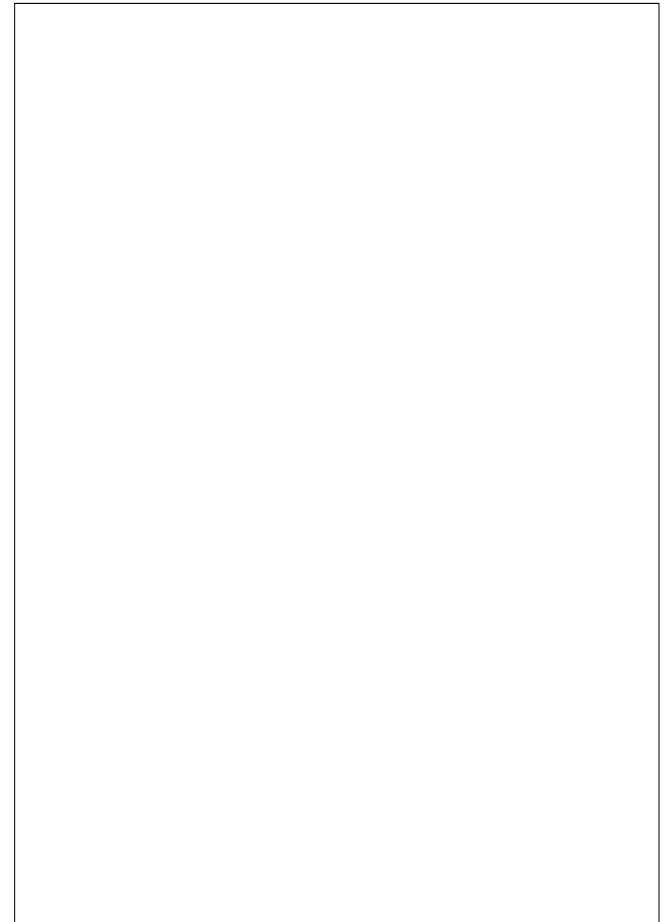
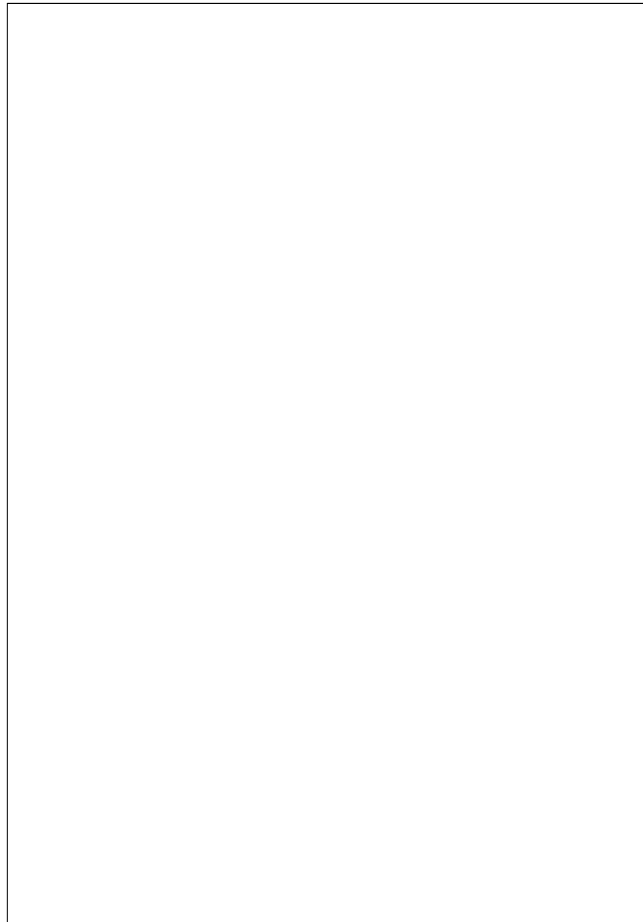
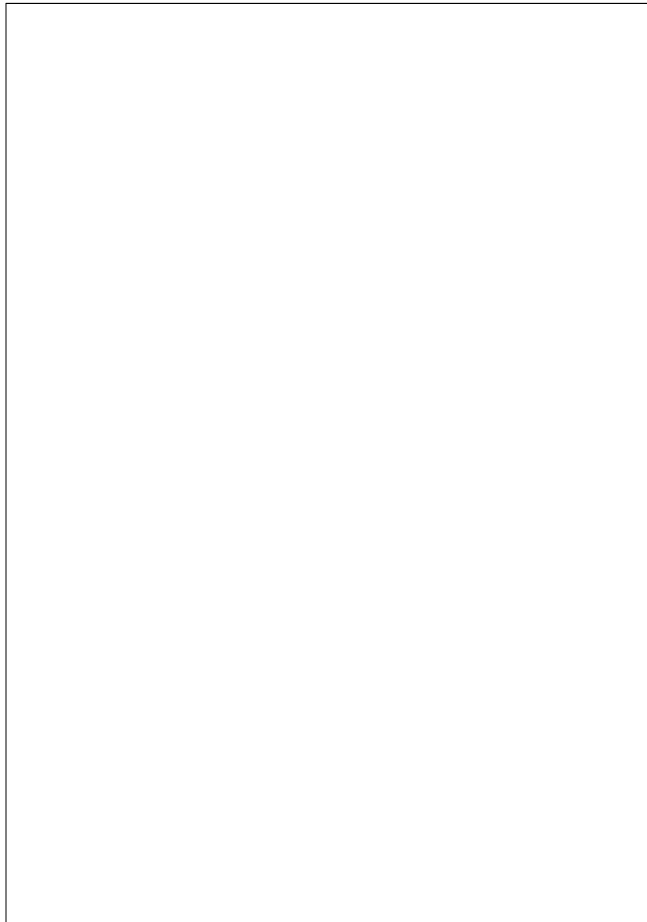

Scene	Duration	Panel	Duration
056	03:17	2	03:06



**Dialogue**  
 40. \*CESAR  
 Ninooooo!

**Action Notes**  
 César jeune appelle Nino

Scene	Duration	Panel	Duration
057	04:01	1	02:24



**Dialogue**  
 40. \*CESAR en fond sonore, comme un écho  
 Ninooooooooo...

Scene	Duration	Panel	Duration
057	04:01	2	01:02

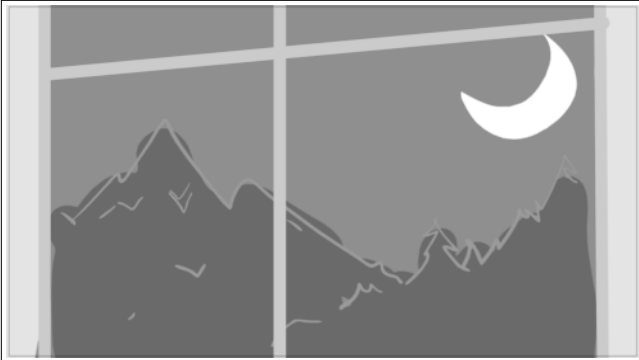

Scene	Duration	Panel	Duration
058	04:05	1	00:06

**Action Notes**

INT BASTIDE NUIT

Scene	Duration	Panel	Duration
058	04:05	2	01:24

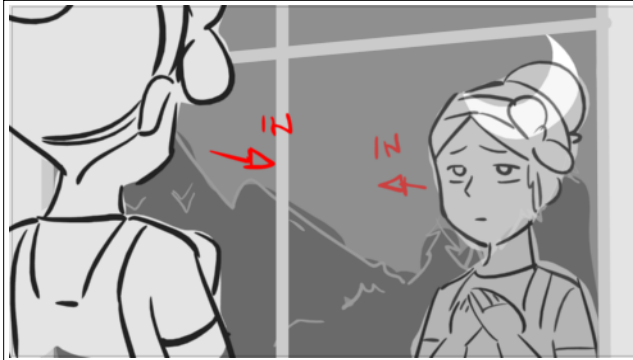
**Dialogue**

41. ANGELINA  
César a tenté de le suivre,

**Action Notes**

ANG IN se reflète dans la fenêtre (FX)

Scene	Duration	Panel	Duration
058	04:05	3	01:11

**Dialogue**

41. ANGELINA  
César a tenté de le suivre, mais...

Scene	Duration	Panel	Duration
058	04:05	4	00:14



**Action Notes**

ANG ferme les yeux  
BEAT

Scene	Duration	Panel	Duration
059	02:04	1	00:09



Scene	Duration	Panel	Duration
059	02:04	2	01:20

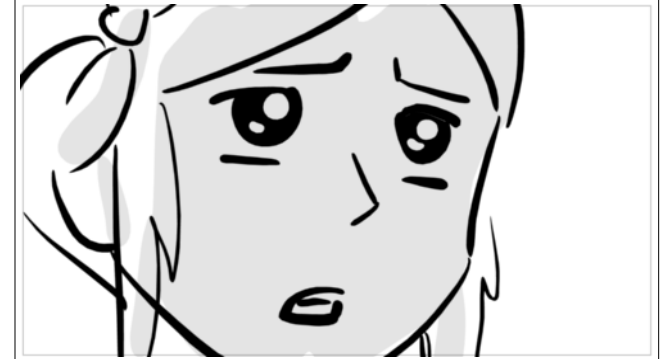

**Dialogue**

41. ANGELINA  
Nino avait déjà disparu...

**Action Notes**

regard douloureux d'ANG

Scene	Duration	Panel	Duration
060	05:01	1	05:01

**Dialogue**

42. ANGELINA

Il a fait tout ce qu'il a pu.. Avec les secours en montagne ils l'ont cherché pendant des heures, des jours,..

**Action Notes**

SLOW PAN

Scene	Duration	Panel	Duration
061	03:15	1	01:07

**Dialogue**

42. ANGELINA

Mais avec cette brume...

Scene	Duration	Panel	Duration
061	03:15	2	01:00



**Dialogue**  
 42. ANGELINA  
 Mais avec cette brume...

**Action Notes**  
 B et S se regardent

Scene	Duration	Panel	Duration
061	03:15	3	01:08



**Dialogue**  
 43. SÉBASTIEN  
 (captivé et choqué) Ils ne l'ont pas retrouvé ?

Scene	Duration	Panel	Duration
062	03:08	1	00:14



**Dialogue**  
 44. ANGELINA  
 Non...

Scene	Duration	Panel	Duration
062	03:08	2	00:11



**Dialogue**  
 44. ANGELINA  
 Non...

Scene	Duration	Panel	Duration
062	03:08	3	02:08



**Dialogue**  
 44. ANGELINA  
 Seulement son sac-à-dos en contrebas  
 de la montagne...

**Action Notes**  
 A pose sa main sur le carreau  
 FX reflet

Scene	Duration	Panel	Duration
063	04:05	1	00:14

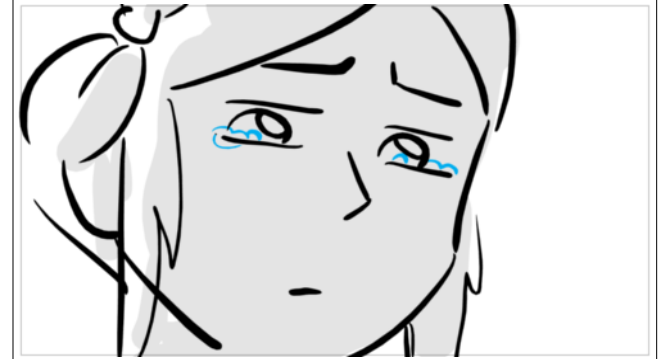

**Dialogue**  
 45. SÉBASTIEN (touché par l'émotion  
 d'Angelina)  
 Tu le connaissais Nino ?

**Action Notes**  
 FX LARMES

Scene	Duration	Panel	Duration
063	04:05	2	01:09



**Action Notes**  
FX LARMES

Scene	Duration	Panel	Duration
063	04:05	3	00:20

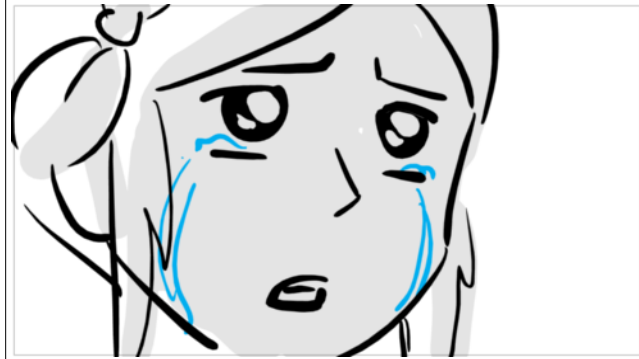

**Dialogue**  
46. ANGELINA (s'essuyant la larme)  
C'était mon... mon parrain.

Scene	Duration	Panel	Duration
063	04:05	4	00:11



**Dialogue**  
46. ANGELINA (s'essuyant la larme)  
C'était mon... mon parrain.

**Action Notes**  
A essuie ses larmes



Scene	Duration	Panel	Duration
063	04:05	5	01:01



## Dialogue

46. ANGELINA (s'essuyant la larme)  
C'était mon... mon parrain.

Scene	Duration	Panel	Duration
064	02:02	1	00:08

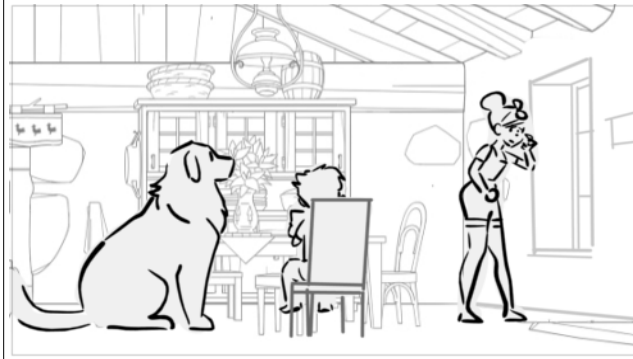

## Dialogue

46. ANGELINA (s'essuyant la larme)  
J'avais à peu près ton âge...

Scene	Duration	Panel	Duration
064	02:02	2	01:19

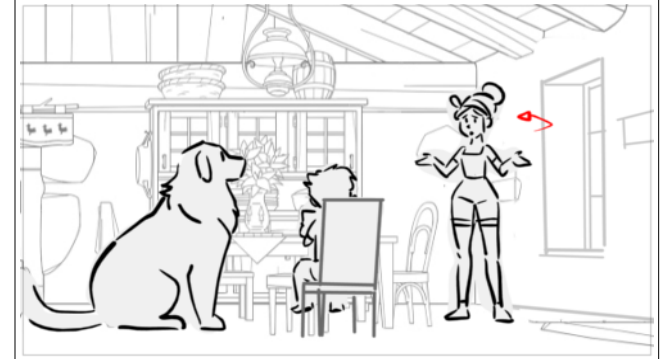

## Dialogue

46. ANGELINA (s'essuyant la larme)  
J'avais à peu près ton âge...

Scene	Duration	Panel	Duration
065	06:05	1	01:08

**Dialogue**

46. ANGELINA (s'essuyant la larme)  
Tu n'étais pas encore né quand c'est  
arrivé.

Scene	Duration	Panel	Duration
065	06:05	2	00:06



Scene	Duration	Panel	Duration
065	06:05	3	00:16



Scene	Duration	Panel	Duration
065	06:05	4	00:19

Scene	Duration	Panel	Duration
065	06:05	5	02:02

Scene	Duration	Panel	Duration
065	06:05	6	00:16



**Dialogue**  
 47. SÉBASTIEN MODIF (grave)  
 D'accord...

Scene	Duration	Panel	Duration
065	06:05	7	00:13



Scene	Duration	Panel	Duration
001_A	04:17	1	00:14



**Action Notes**

EXT - BASTIDE - JOUR (MATIN)



Scene	Duration	Panel	Duration
001_A	04:17	2	02:12

NO PANEL

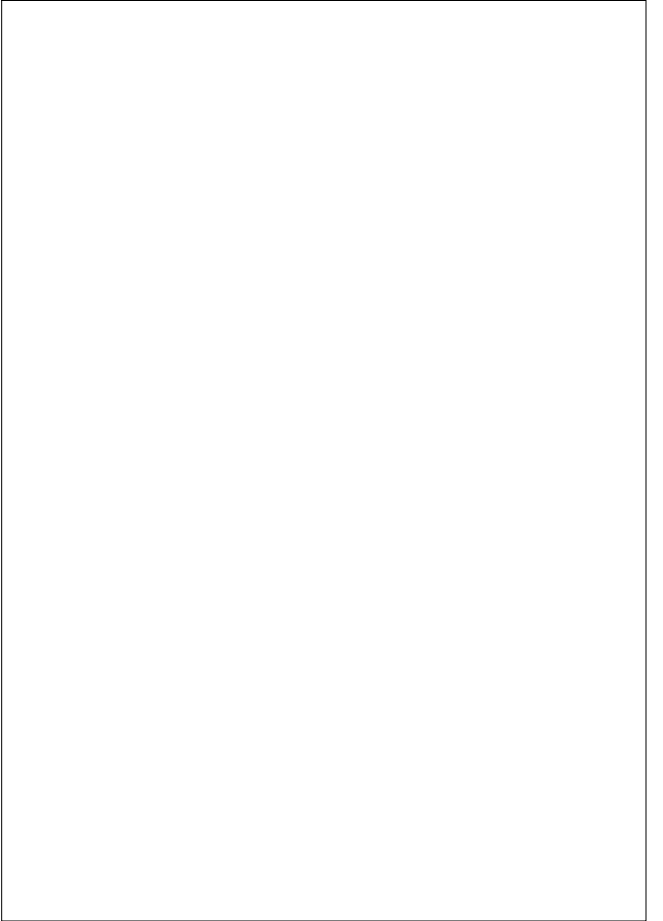
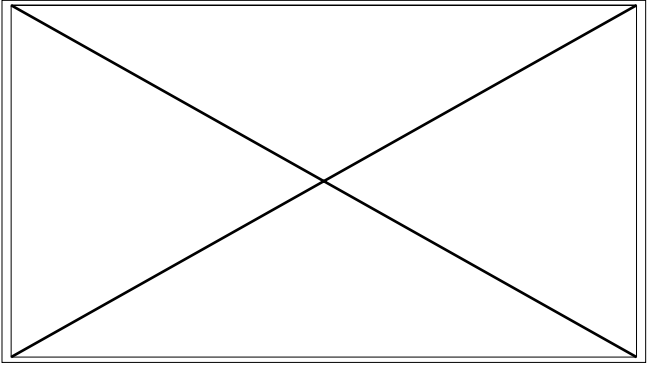

Scene	Duration	Panel	Duration
001_A	04:17	3	01:16



Scene	Duration	Panel	Duration
069	05:03	1	01:00

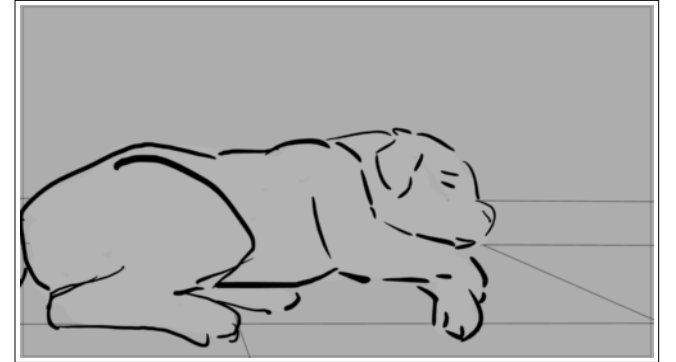

**Action Notes**

8. INT - BASTIDE - MATIN- PENOMBRE  
B dort

Scene	Duration	Panel	Duration
069	05:03	2	00:15

Scene	Duration	Panel	Duration
069	05:03	3	00:15

Scene	Duration	Panel	Duration
069	05:03	4	00:15

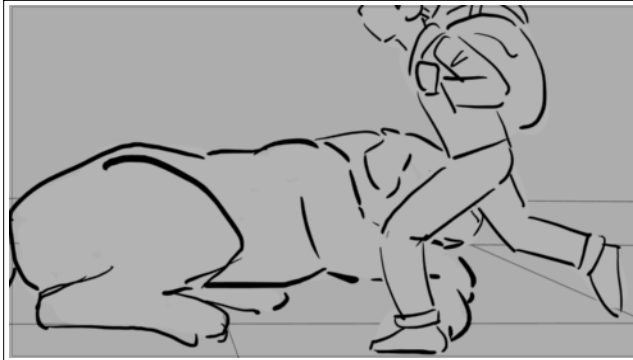
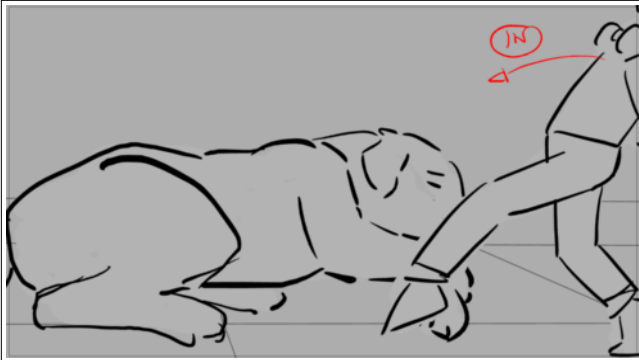

**Action Notes**

Sébastien IN, sac sur le dos, en tenue d'alpiniste, marche à petits pas pour ne pas faire de bruit.

Scene	Duration	Panel	Duration
069	05:03	5	00:13



**Action Notes**

B ouvre un oeil

Scene	Duration	Panel	Duration
069	05:03	6	00:13

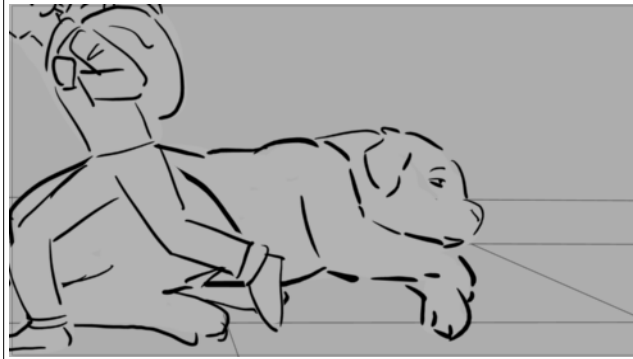

Scene	Duration	Panel	Duration
069	05:03	7	00:14

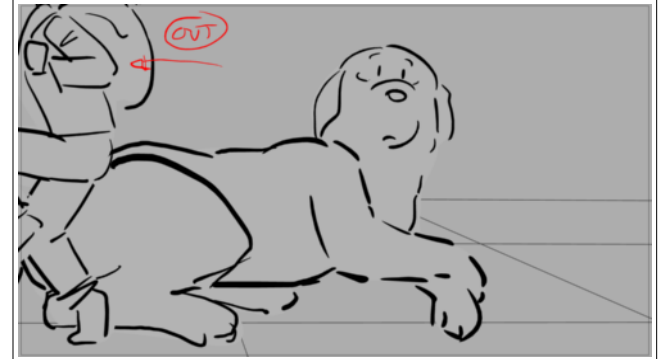

**Action Notes**

B se réveille



Scene	Duration	Panel	Duration
069	05:03	8	00:18

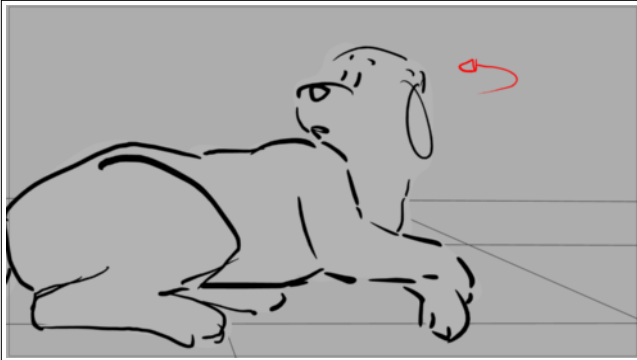

**Action Notes**

B se tourne vers SEB

Scene	Duration	Panel	Duration
070	03:00	1	00:14



**Dialogue**

48. BELLE  
Wouf ?

**Action Notes**

SEB tient une lettre à la main

Scene	Duration	Panel	Duration
070	03:00	2	01:03



**Dialogue**

48. BELLE  
Wouf ?

Scene	Duration	Panel	Duration
070	03:00	3	01:08



**Dialogue**  
 PU SEBASTIEN  
 Chhhut

Scene	Duration	Panel	Duration
071	04:06	1	01:03



**Action Notes**  
 PAN FOLLOW BELLE

Scene	Duration	Panel	Duration
071	04:06	2	01:00



**Dialogue**  
 49. SÉBASTIEN  
 Oui Belle,

**Action Notes**  
 SEB carresse le museau de Belle

Scene	Duration	Panel	Duration
071	04:06	3	01:09



**Dialogue**  
 49. SÉBASTIEN  
 on va quand même y aller.

Scene	Duration	Panel	Duration
071	04:06	4	00:19



**Dialogue**  
 49. SÉBASTIEN  
 Pour Nino et César!

**Action Notes**  
 SEb regarde sa lettre

Scene	Duration	Panel	Duration
072	04:00	1	00:13

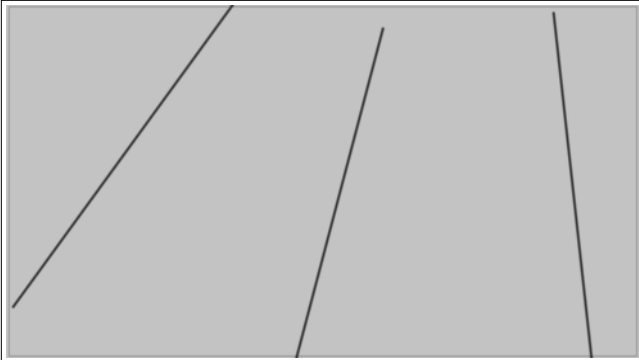

**Dialogue**  
 49. SÉBASTIEN  
 Pour Nino et César!

Scene	Duration	Panel	Duration
072	04:00	2	00:14

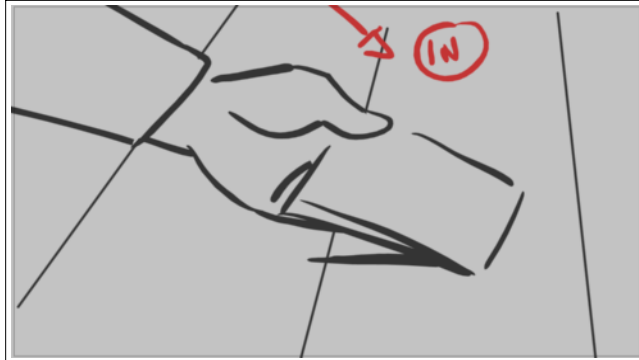

**Action Notes**  
 Main de SEB IN dépose la lettre sur la table

Scene	Duration	Panel	Duration
072	04:00	3	01:10

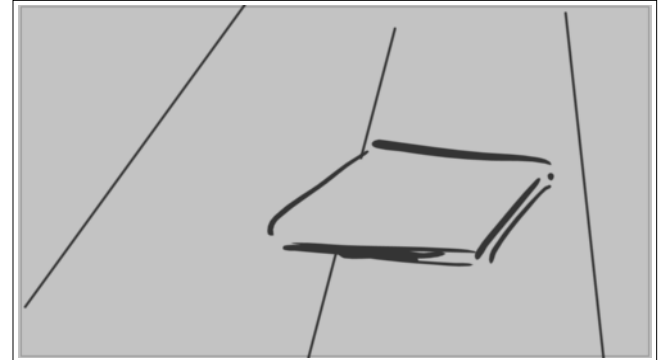

Scene	Duration	Panel	Duration
072	04:00	4	00:13

Scene	Duration	Panel	Duration
072	04:00	5	01:00

Scene	Duration	Panel	Duration
073	01:24	1	00:11

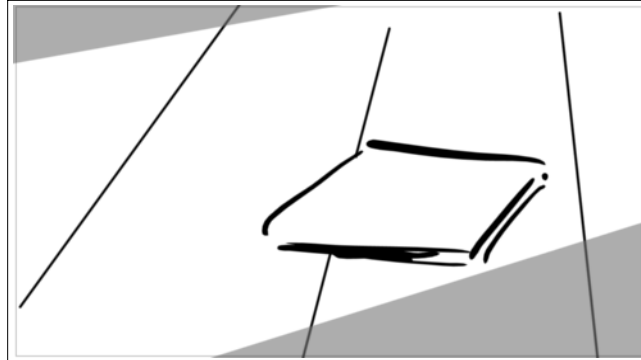
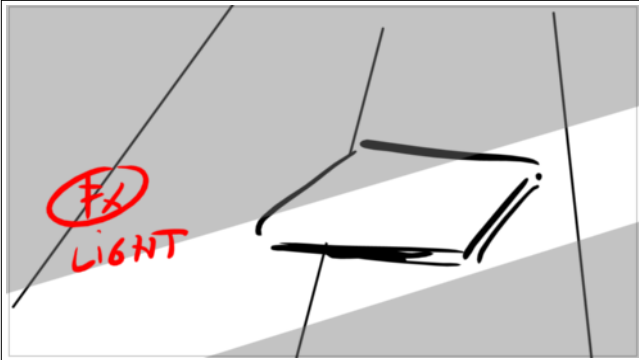

**Action Notes**

FX rayon de lumière du à l'ouverture de la porte

**Action Notes**

SEB à l'extérieur ferme la porte



Scene	Duration	Panel	Duration
073	01:24	2	00:13

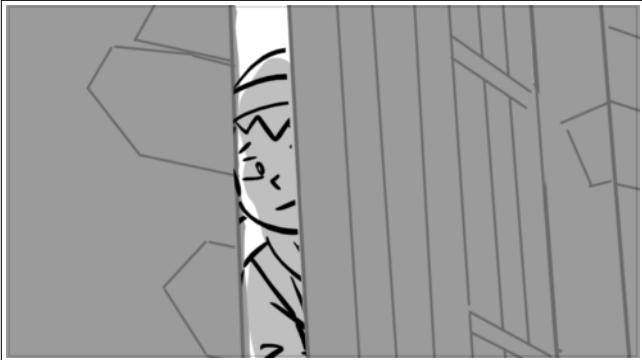

Scene	Duration	Panel	Duration
073	01:24	3	01:00

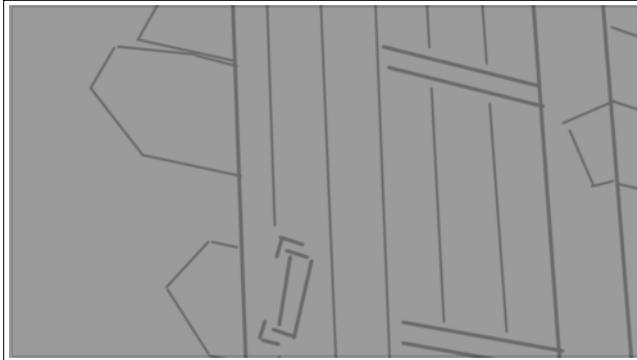

Scene	Duration	Panel	Duration
074	05:02	1	00:22

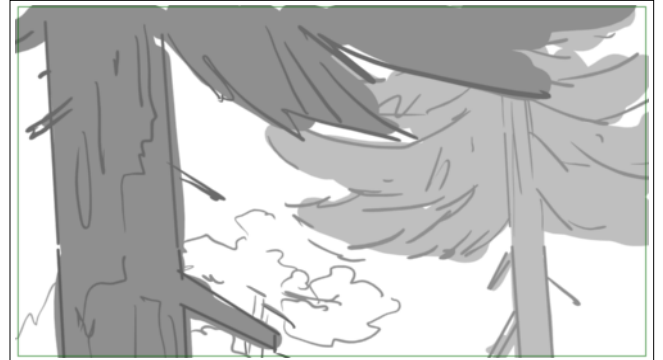

**Action Notes**

EXT MONTAGNE JOUR

Scene	Duration	Panel	Duration
074	05:02	2	02:05

Scene	Duration	Panel	Duration
074	05:02	3	01:00

Scene	Duration	Panel	Duration
074	05:02	4	01:00

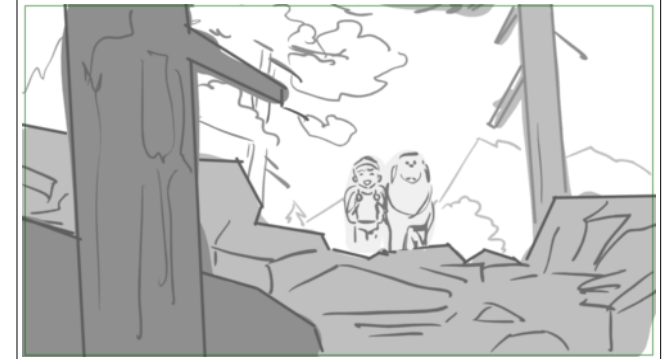
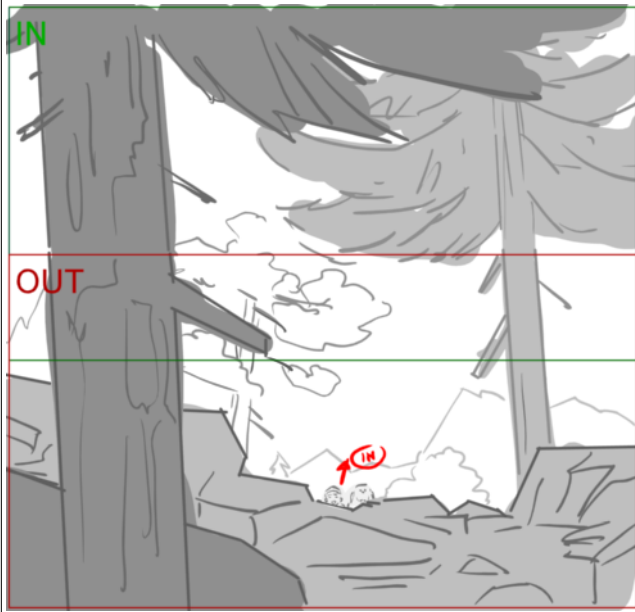

**Dialogue**  
 49. SÉBASTIEN  
 S'ils avaient eu un chien comme toi avec eux,

**Dialogue**  
 49. SÉBASTIEN  
 S'ils avaient eu un chien comme toi avec eux,

**Action Notes**  
 PAN DOWN  
 SEB et BELLE IN

Scene	Duration	Panel	Duration
075	02:14	1	01:00



**Dialogue**  
 49. SÉBASTIEN  
 ils auraient atteint le sommet c'est sûr.

**Action Notes**  
 PAN BG

Scene	Duration	Panel	Duration
075	02:14	2	00:14



**Dialogue**  
 PU BELLE  
 Wouf !< ABOIEMENT POSITIF >

Scene	Duration	Panel	Duration
075	02:14	3	01:00



**Dialogue**  
 49. SÉBASTIEN  
 Et tu verras,





Scene	Duration	Panel	Duration
076	03:24	1	03:24

Dissolve	Duration
	00:12

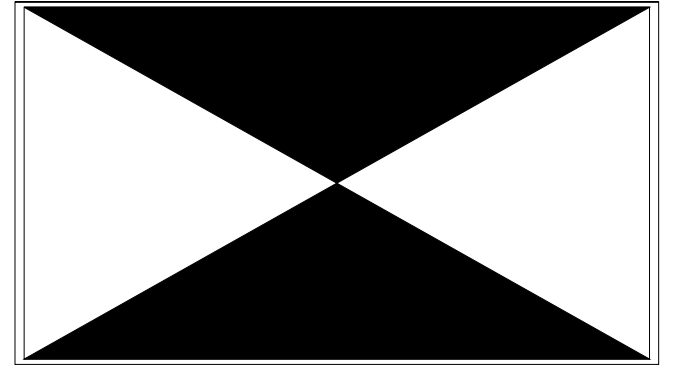

**Dialogue**

49. SÉBASTIEN  
quand on aura réussi, ça fera du bien à Angelina aussi.

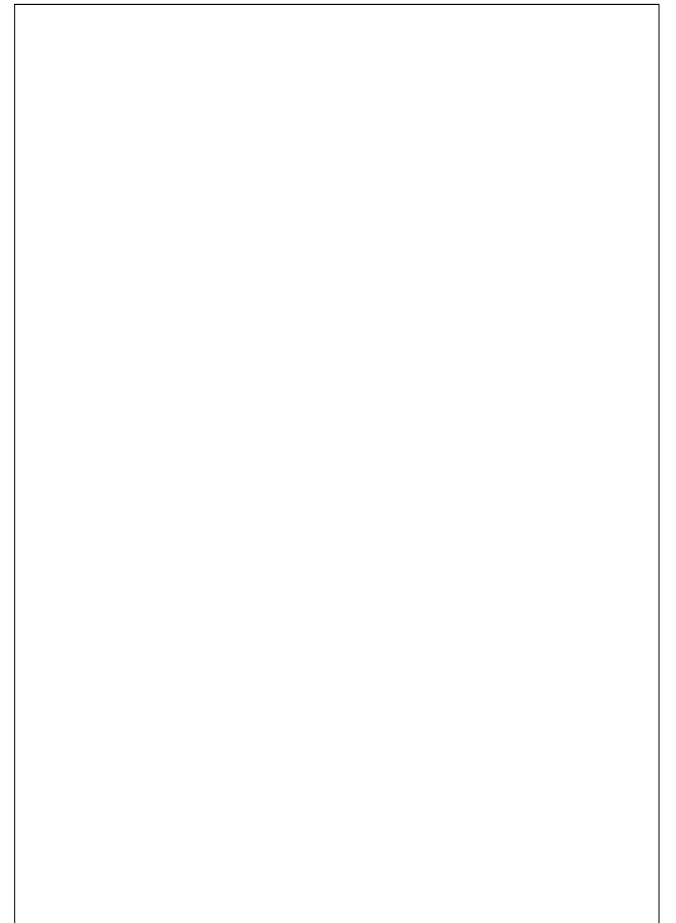



Scene	Duration	Panel	Duration
077	03:14	1	01:00

NO PANEL

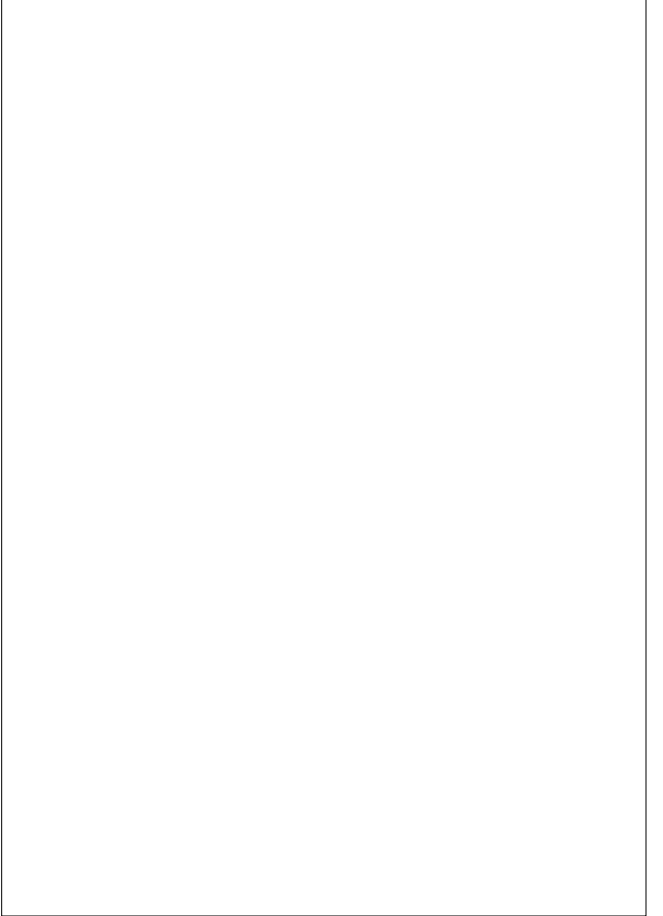
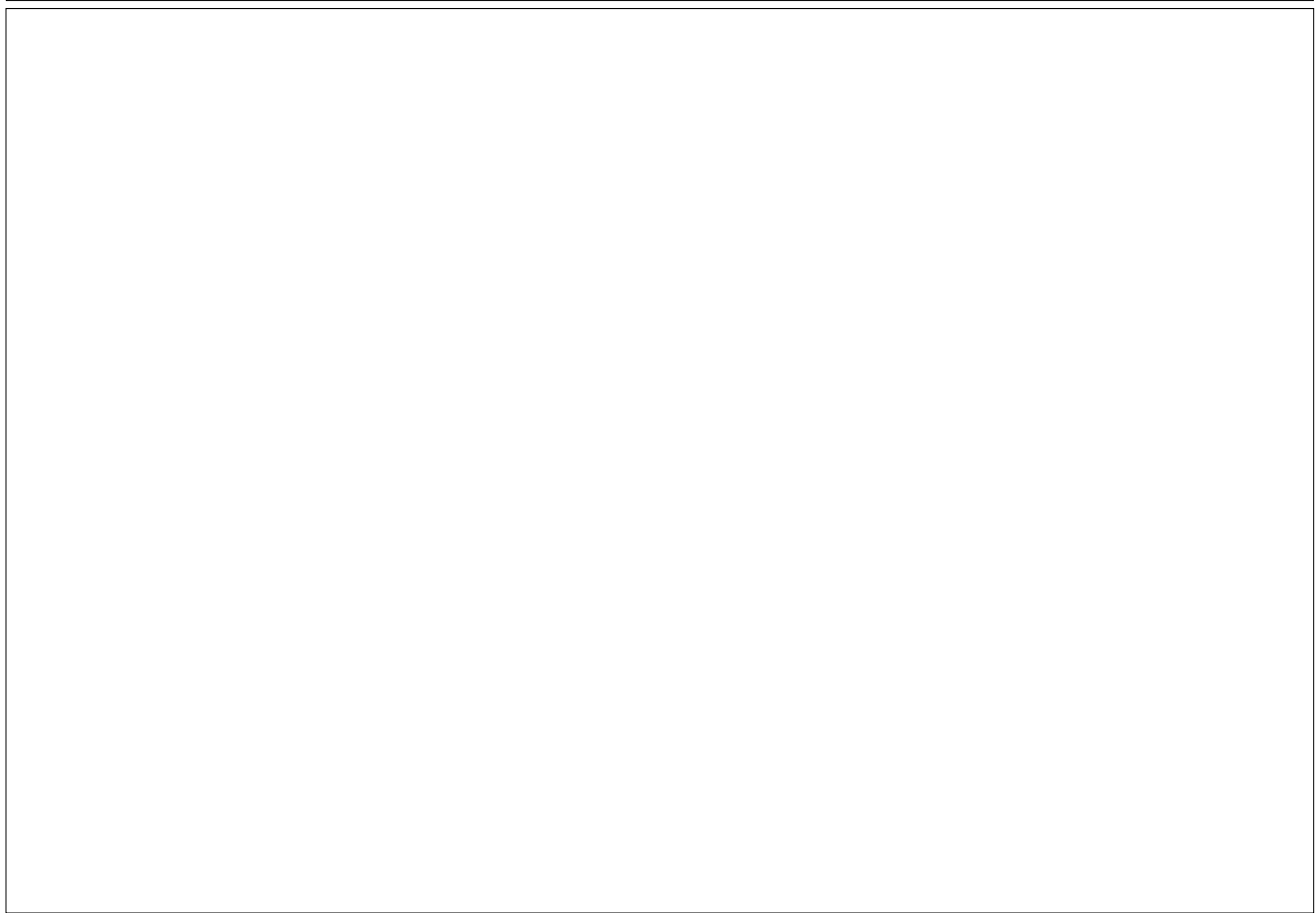
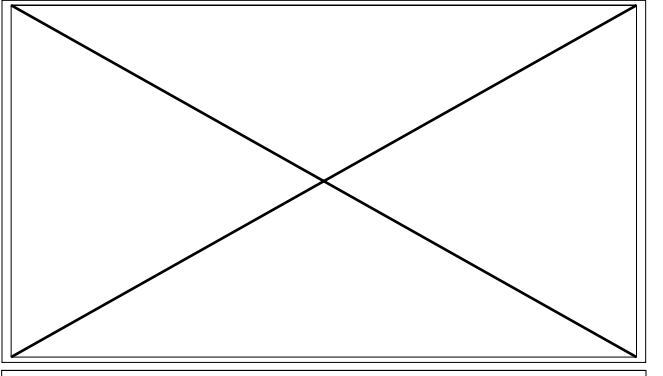



Scene	Duration	Panel	Duration
077	03:14	2	01:00

NO PANEL

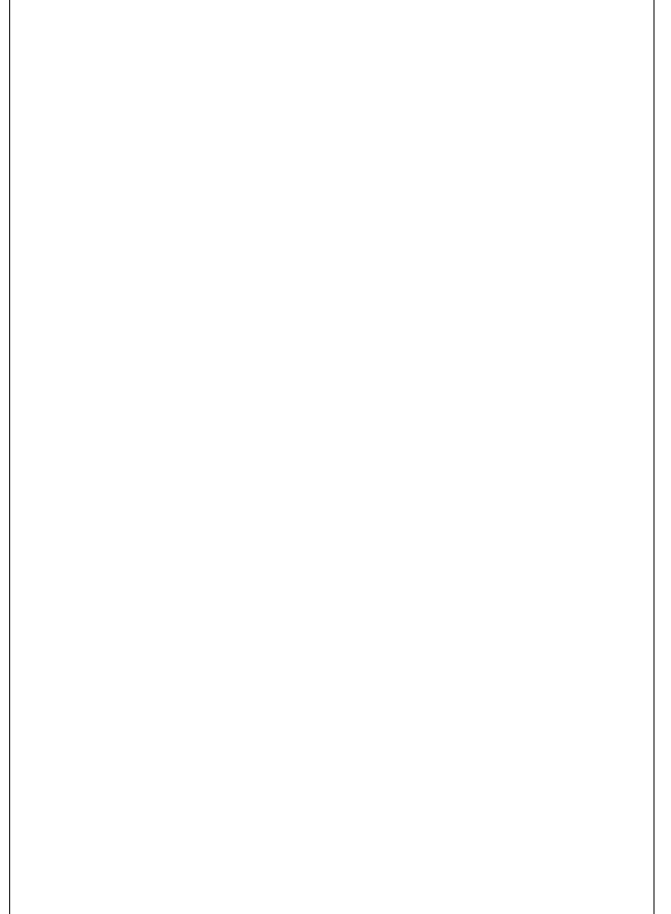
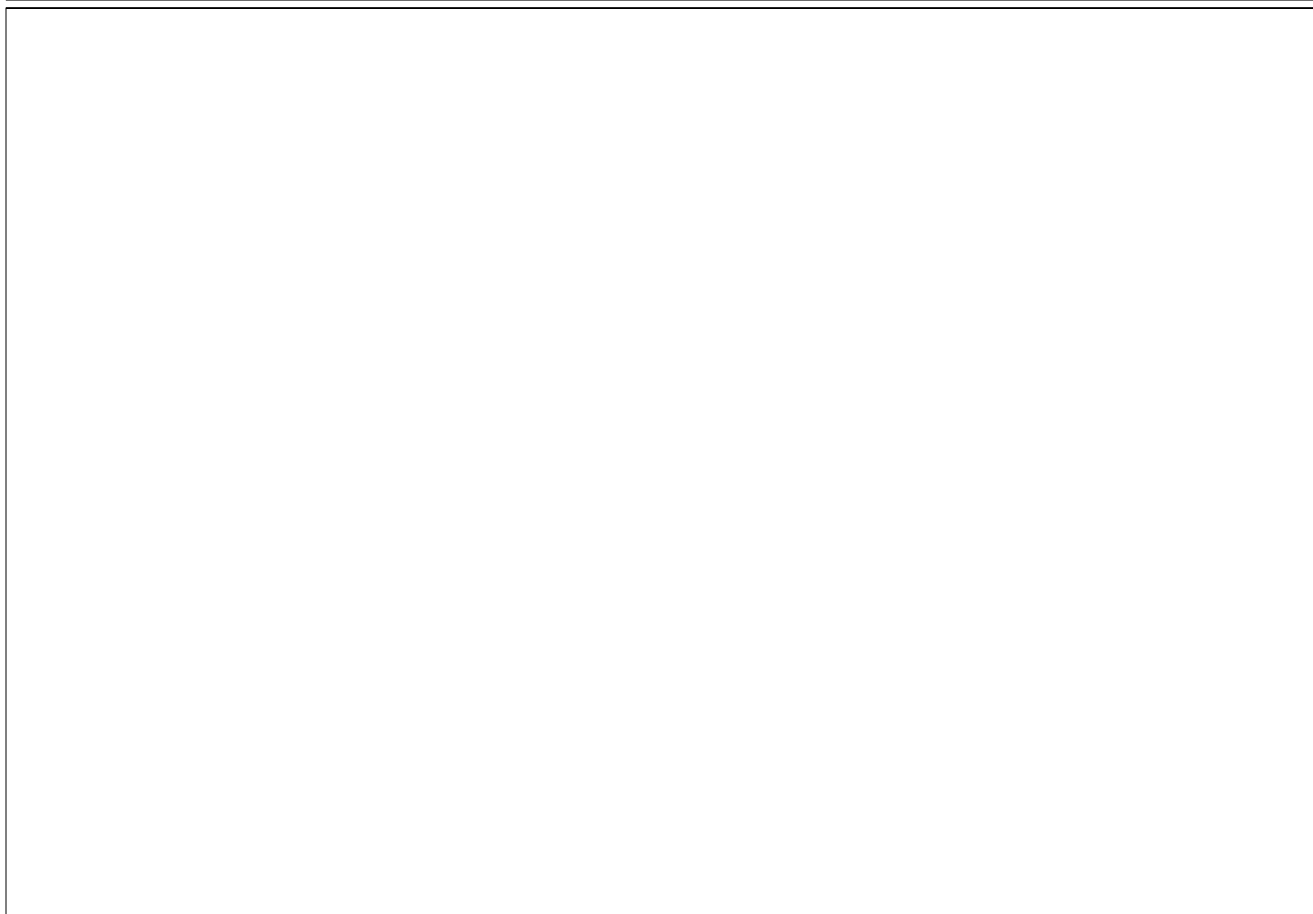
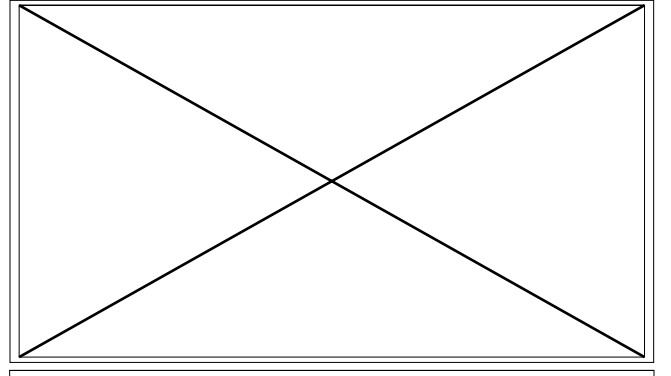
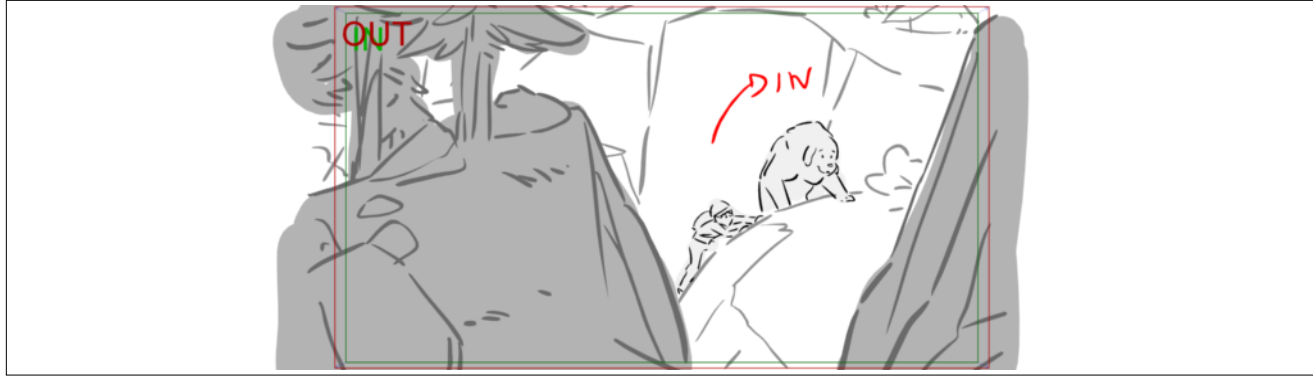



Scene	Duration	Panel	Duration
077	03:14	3	01:14

Dissolve	Duration
	00:12

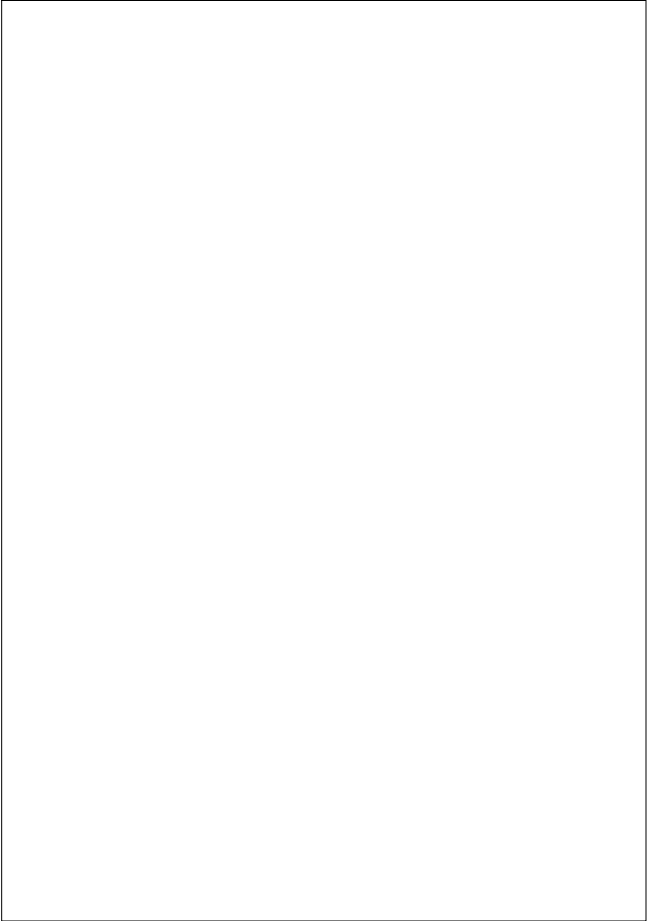
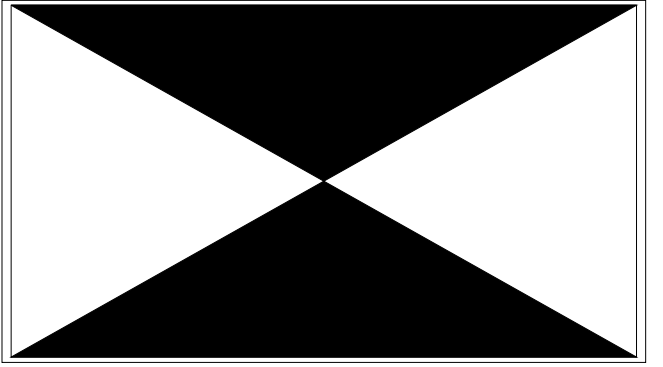
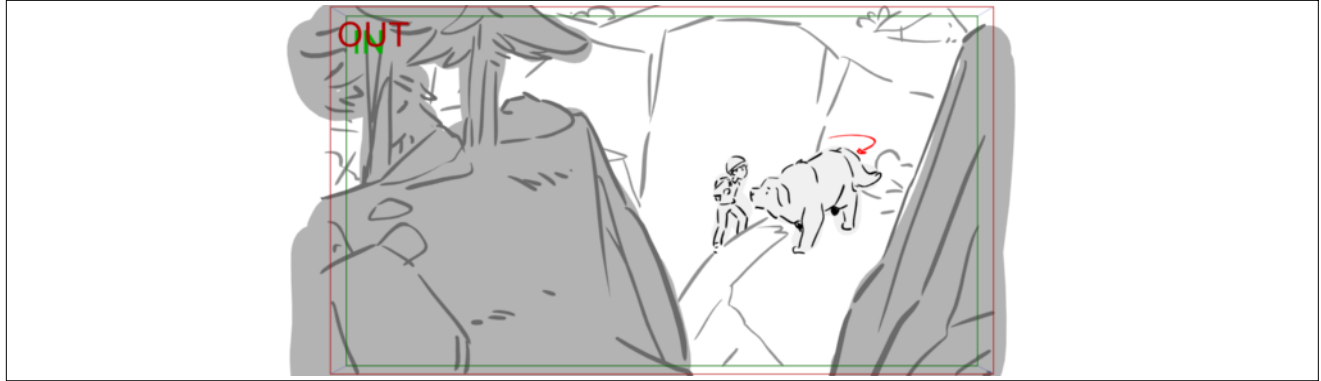

Scene	Duration	Panel	Duration
078	03:21	1	03:21

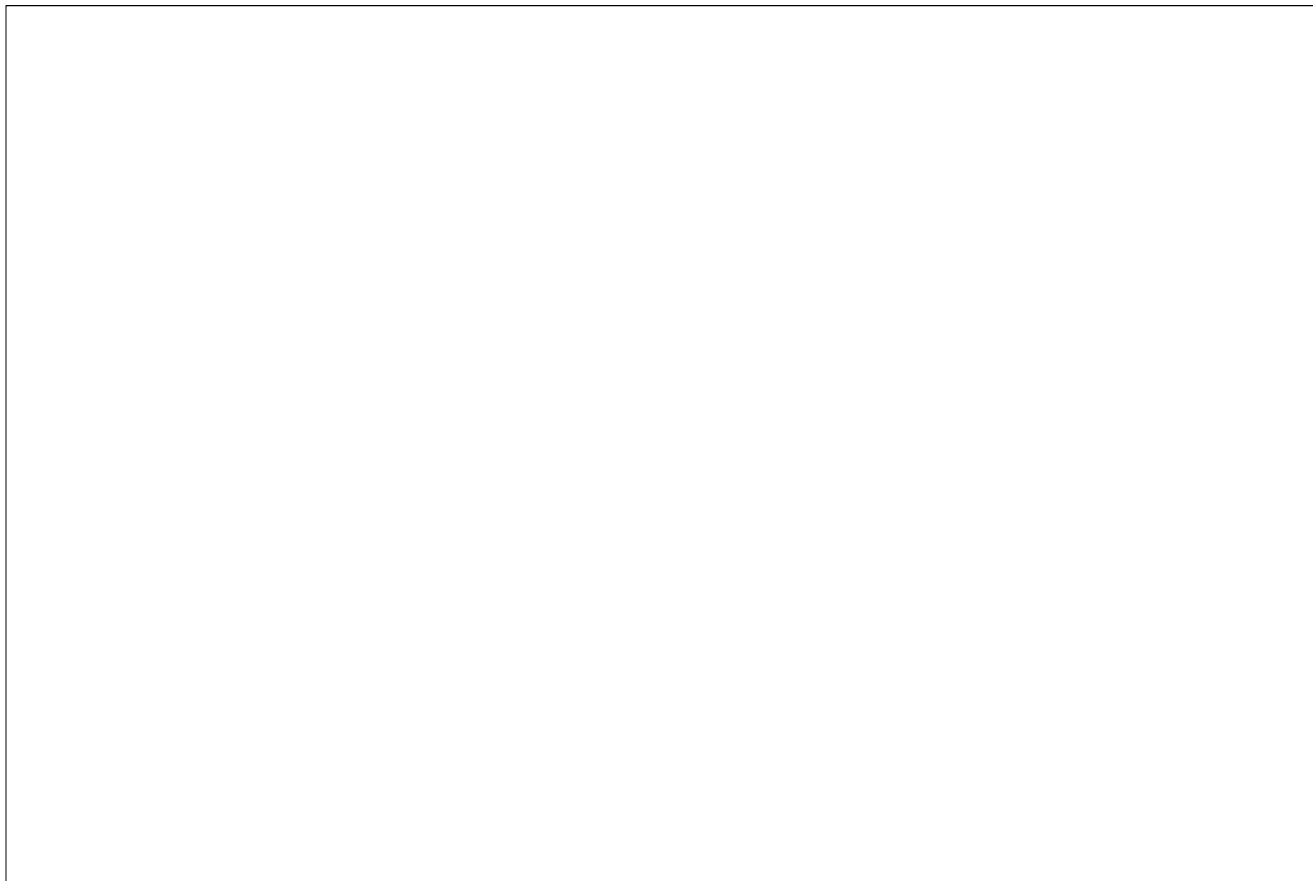
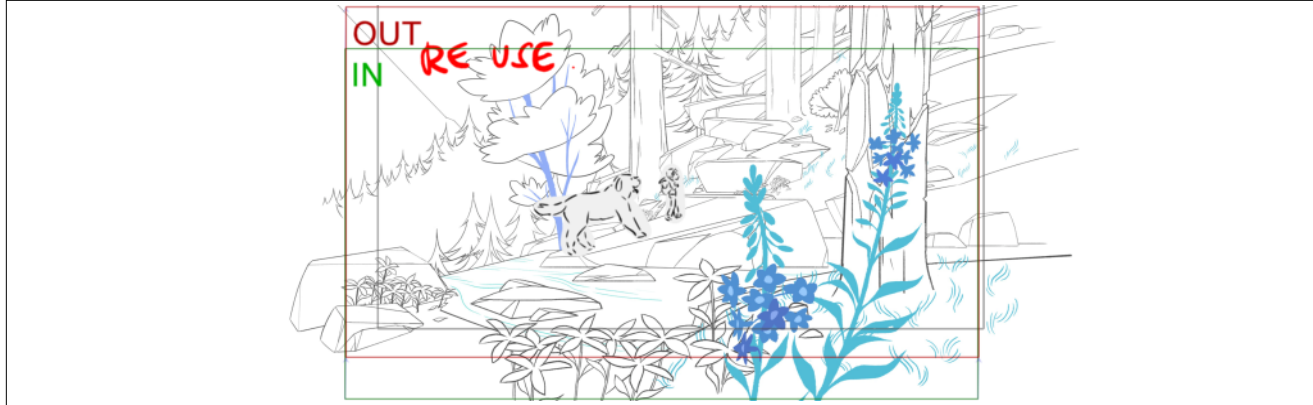

Scene	Duration	Panel	Duration
101_A	06:00	1	04:03

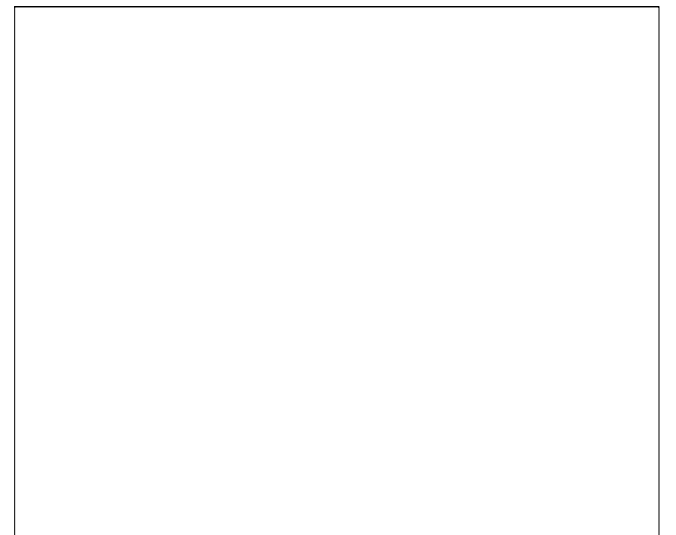
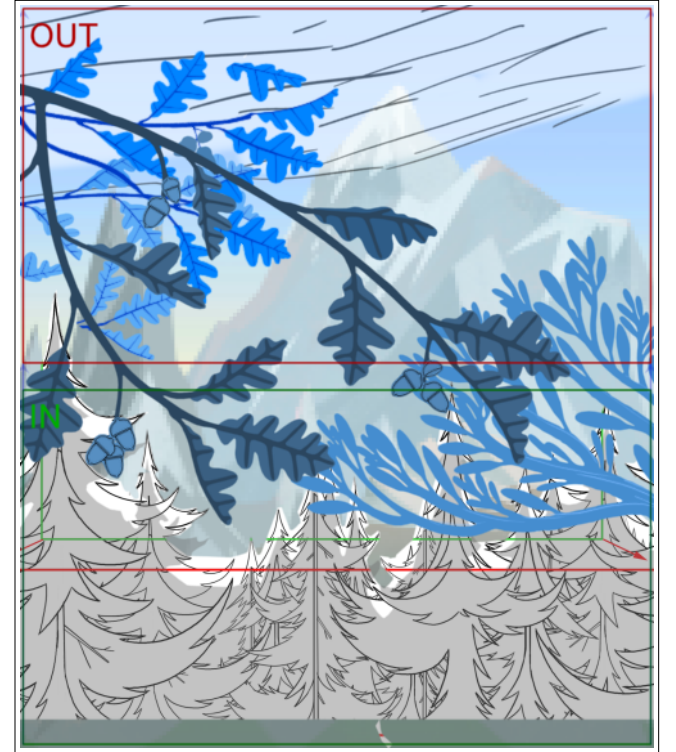

Scene	Duration	Panel	Duration
101_A	06:00	2	01:22

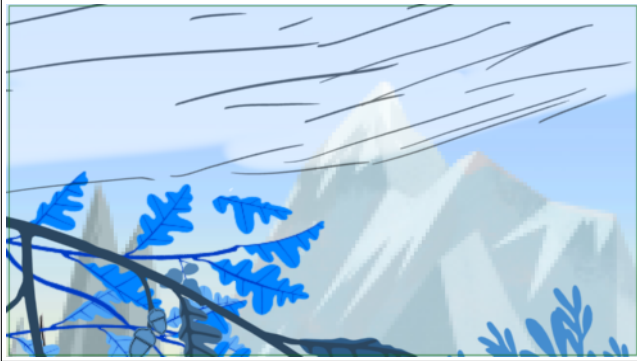

Scene	Duration	Panel	Duration
080	05:11	1	00:17



Scene	Duration	Panel	Duration
080	05:11	2	01:07

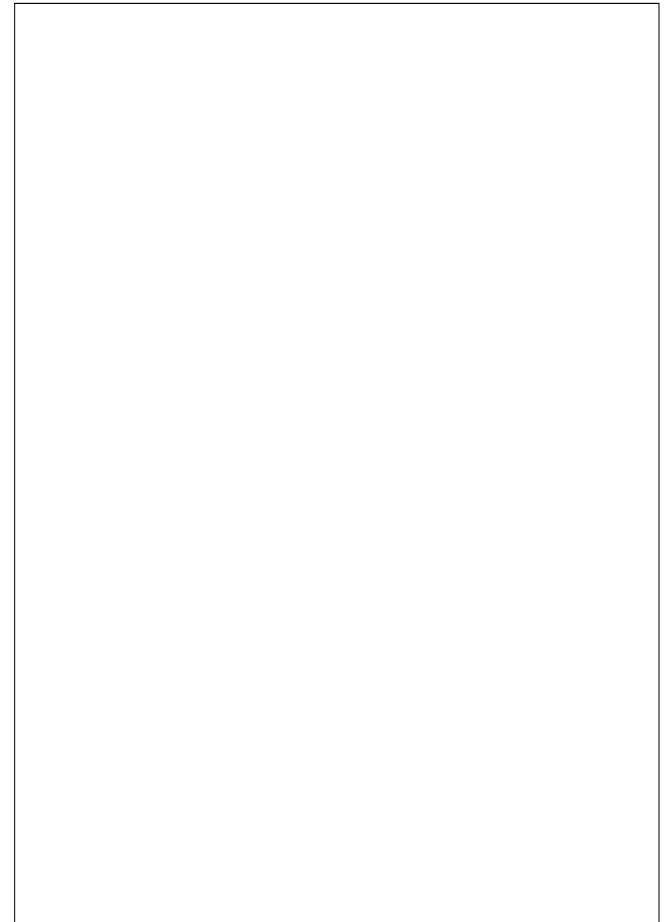
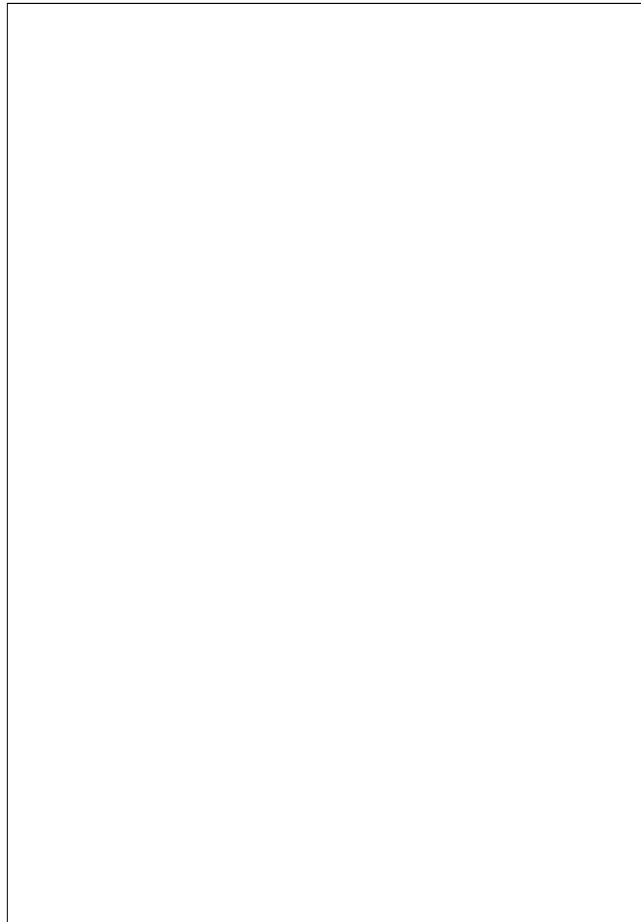
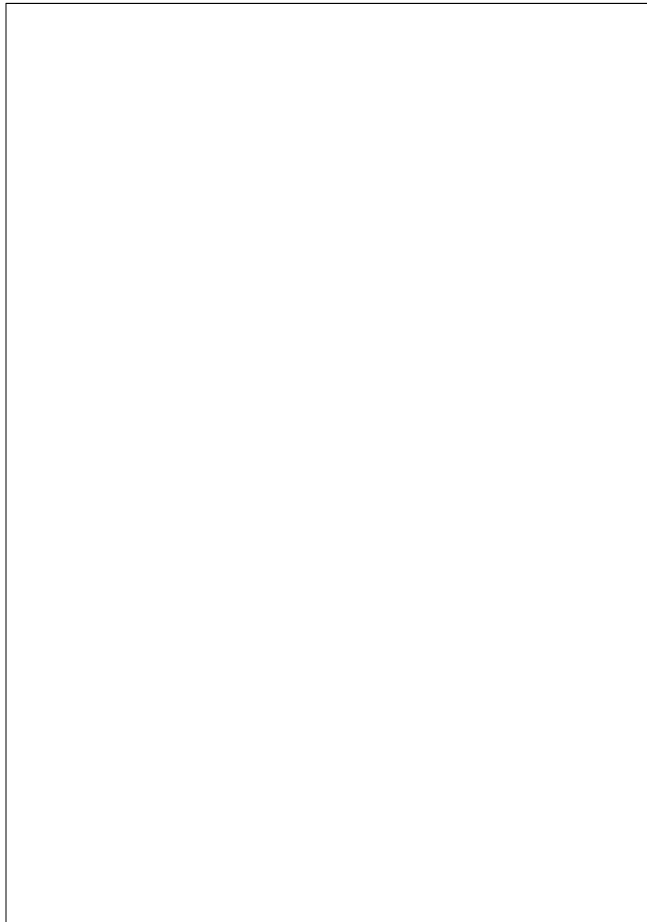
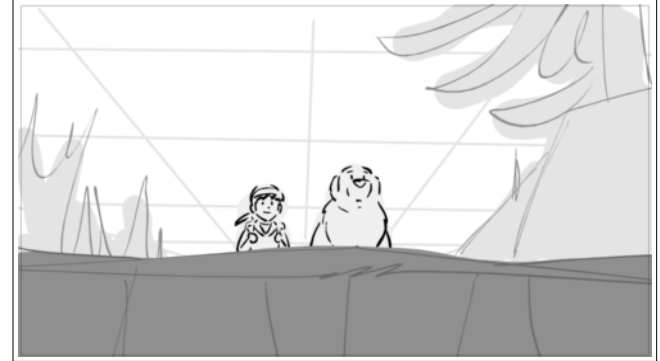

Scene	Duration	Panel	Duration
080	05:11	3	00:24



**Dialogue**

52. SÉBASTIEN (regard de défi)  
A nous deux !

Scene	Duration	Panel	Duration
080	05:11	4	01:13



**Dialogue**

52. SÉBASTIEN (regard de défi)  
A nous deux !

Scene	Duration	Panel	Duration
080	05:11	5	00:13



**Dialogue**

53. BELLE (rappelle qu'elle est là)  
Wouf !

Scene	Duration	Panel	Duration
080	05:11	6	00:12

**Dialogue**

53. BELLE (rappelle qu'elle est là)  
Wouf !

Scene	Duration	Panel	Duration
081	03:18	1	00:06



Scene	Duration	Panel	Duration
081	03:18	2	00:09

**Dialogue**

54. SÉBASTIEN MODIF (trouve qu'elle  
joue sur les mots)  
Oui Belle...



Scene	Duration	Panel	Duration
081	03:18	3	00:23

**Dialogue**

54. SÉBASTIEN MODIF (trouve qu'elle joue sur les mots)  
Oui Belle...

**Action Notes**

SEB hausse les épaules et lève les yeux au ciel

Scene	Duration	Panel	Duration
081	03:18	4	00:20

**Dialogue**

54. SÉBASTIEN MODIF (trouve qu'elle joue sur les mots)  
Oui Belle...

Scene	Duration	Panel	Duration
081	03:18	5	01:10





Scene	Duration	Panel	Duration
082	12:23	1	02:22

NO PANEL

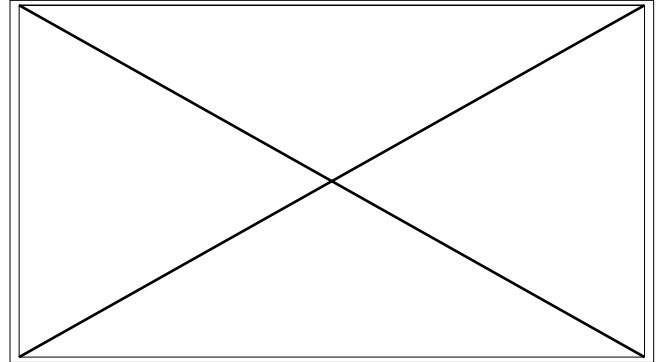
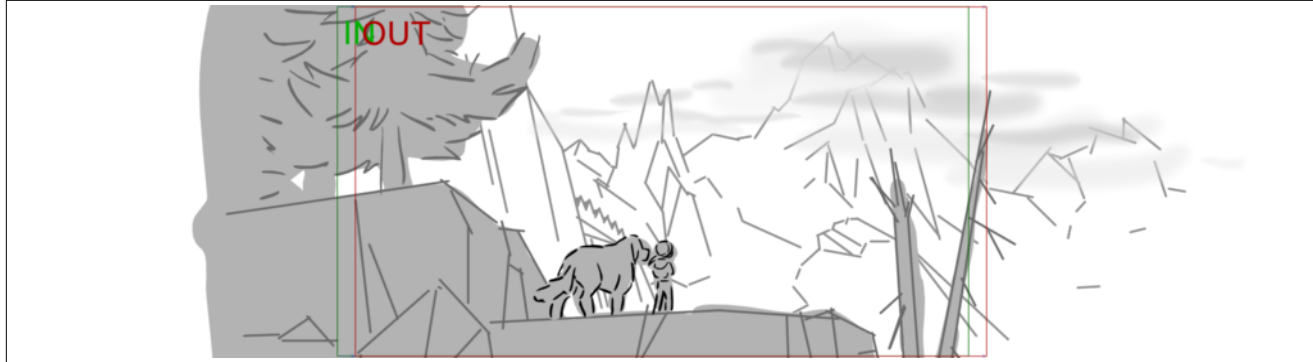

**Dialogue**  
54. SÉBASTIEN (trouve qu'elle joue sur les mots)  
A nous trois si tu préfères !

**Action Notes**  
ESTAB PIC sans nom dans la brume

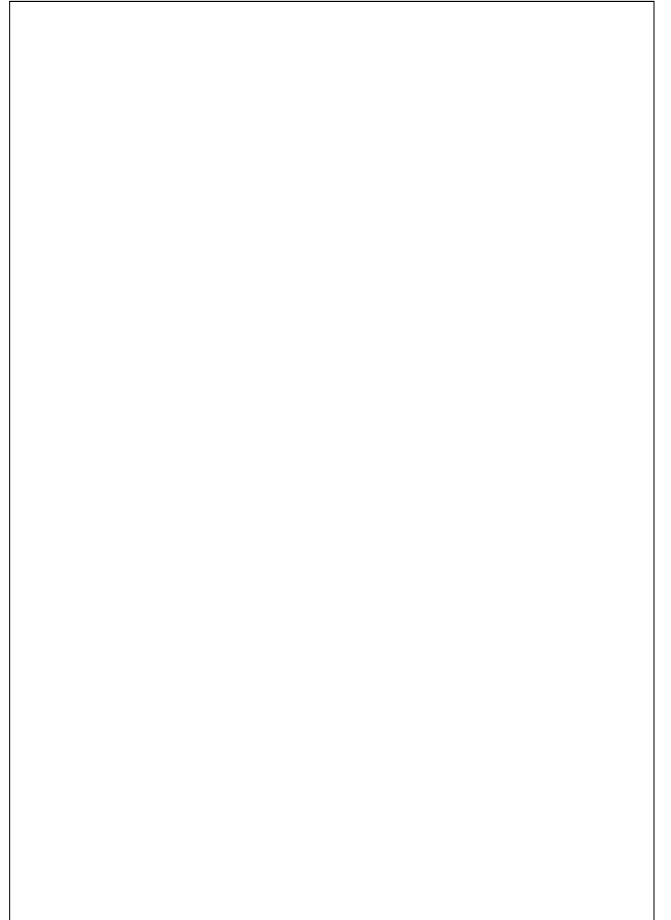

Scene	Duration	Panel	Duration
082	12:23	2	01:11

**Dialogue**

54. SÉBASTIEN (trouve qu'elle joue sur les mots)  
A nous trois si tu préfères !

NO PANEL

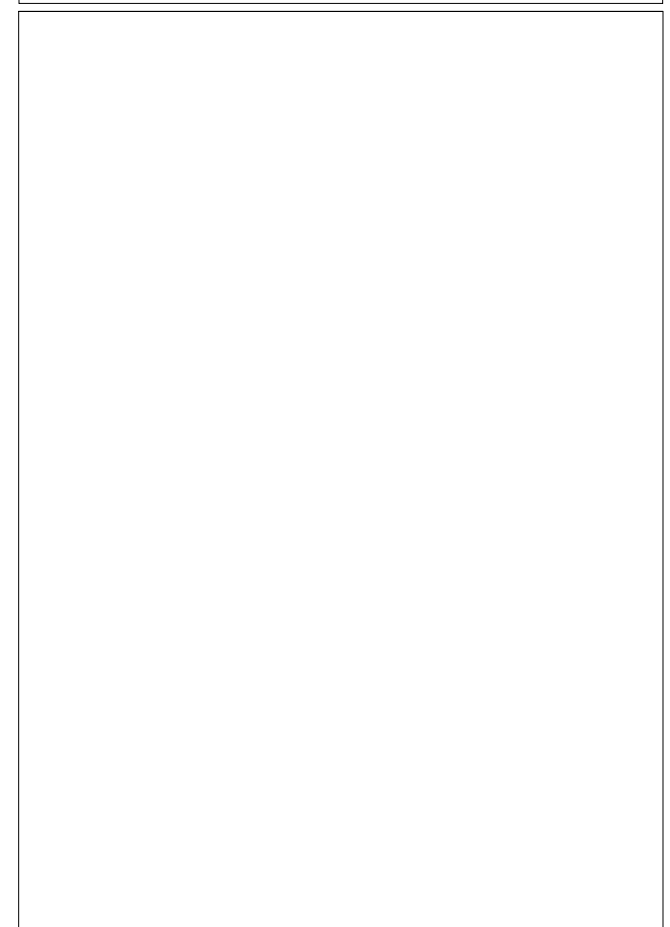
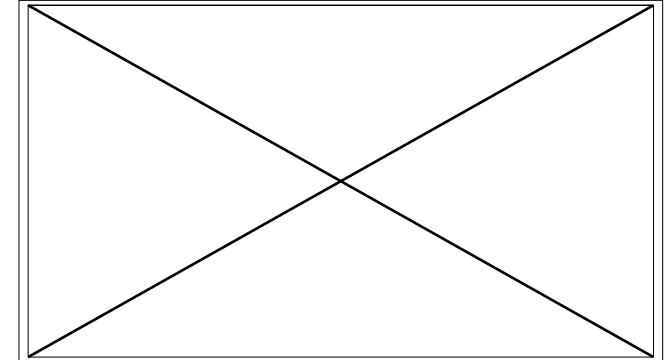

Scene	Duration	Panel	Duration
082	12:23	3	00:22

**Dialogue**

54. SÉBASTIEN (trouve qu'elle joue sur les mots)  
A nous trois si tu préfères !

NO PANEL

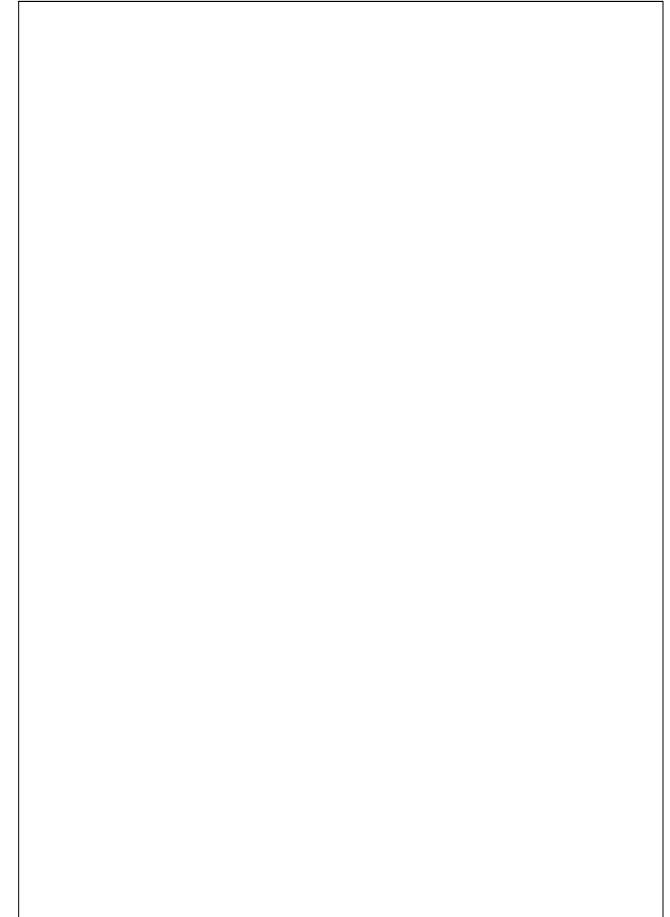
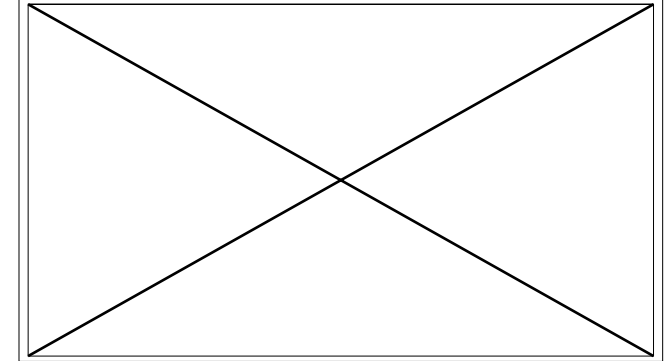

Scene	Duration	Panel	Duration
082	12:23	4	03:05

**Dialogue**

54. SÉBASTIEN (trouve qu'elle joue sur les mots)  
A nous trois si tu préfères !

NO PANEL

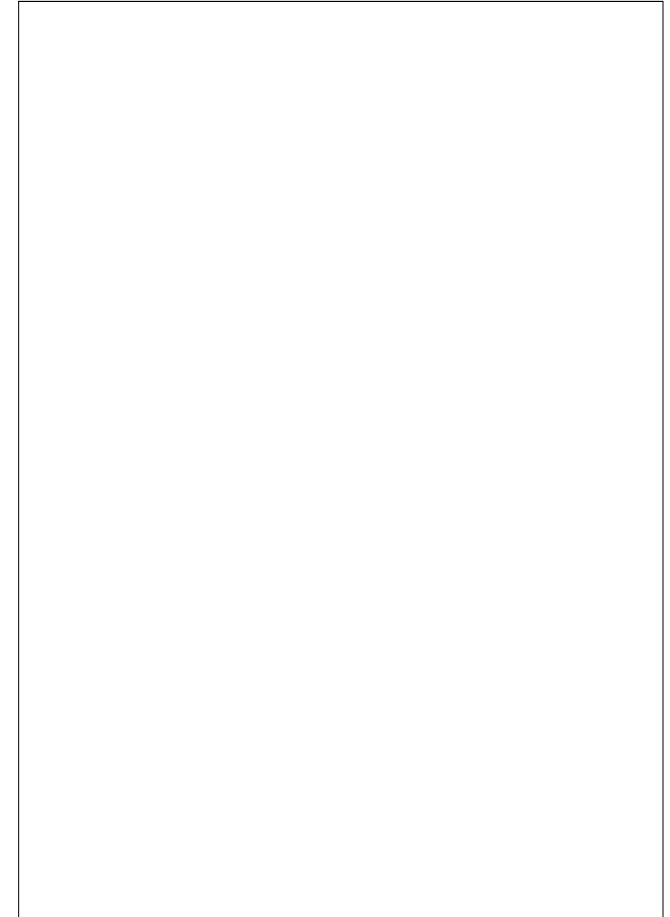
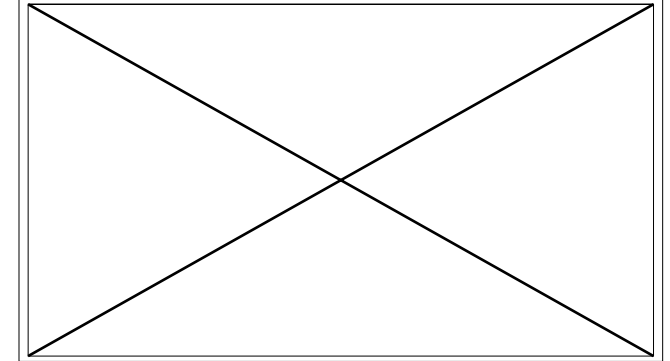

Scene	Duration	Panel	Duration
082	12:23	5	01:09

**Dialogue**

54. SÉBASTIEN (trouve qu'elle joue sur les mots)  
A nous trois si tu préfères !

NO PANEL

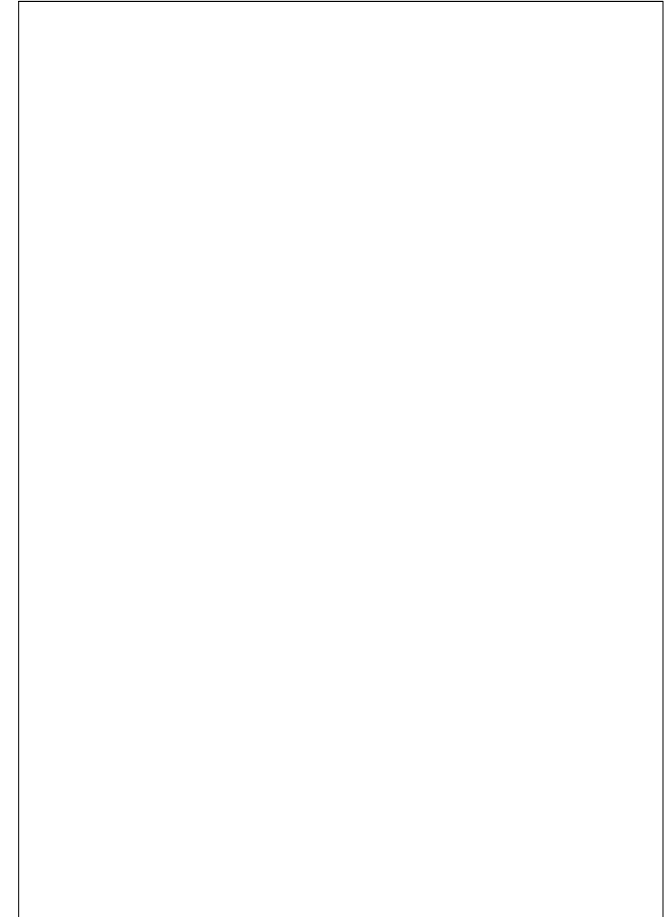
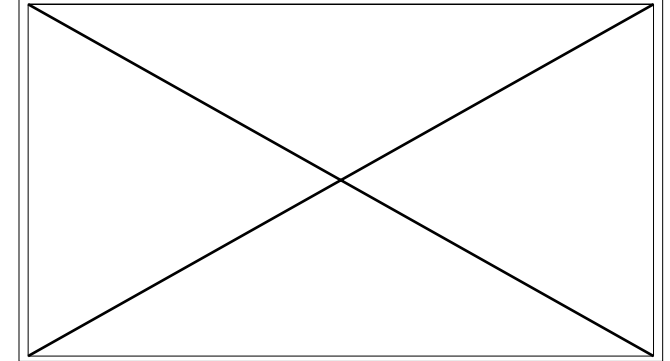

Scene	Duration	Panel	Duration
082	12:23	6	00:14

**Dialogue**

54. SÉBASTIEN (trouve qu'elle joue sur les mots)  
A nous trois si tu préfères !

NO PANEL

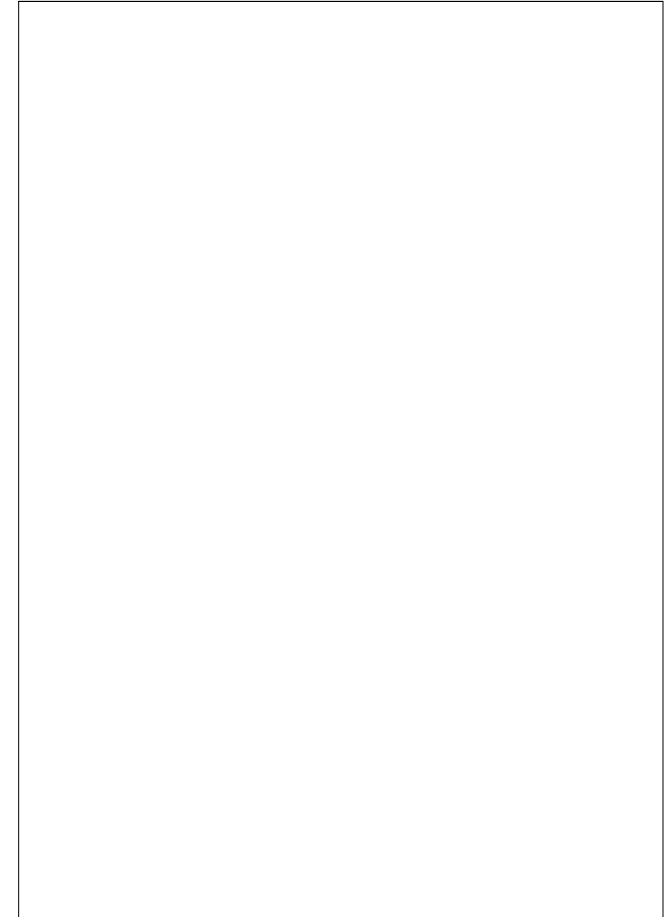
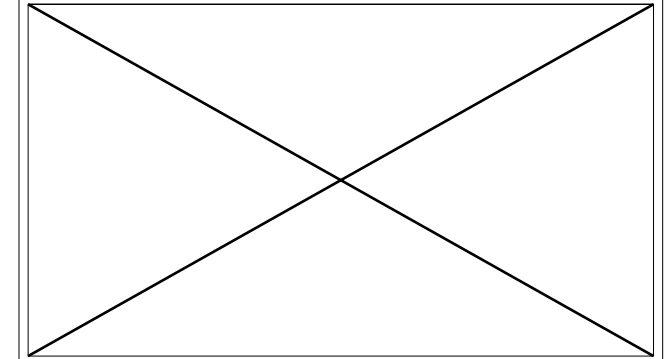



Scene	Duration	Panel	Duration
082	12:23	7	00:12

NO PANEL

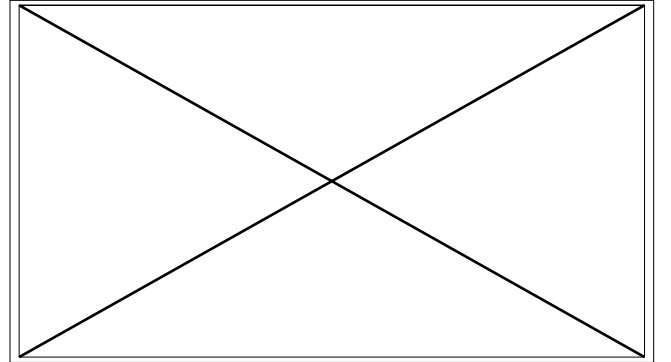

**Dialogue**  
54. SÉBASTIEN (trouve qu'elle joue sur les mots)  
A nous trois si tu préfères !

**Action Notes**  
SEB court OUT

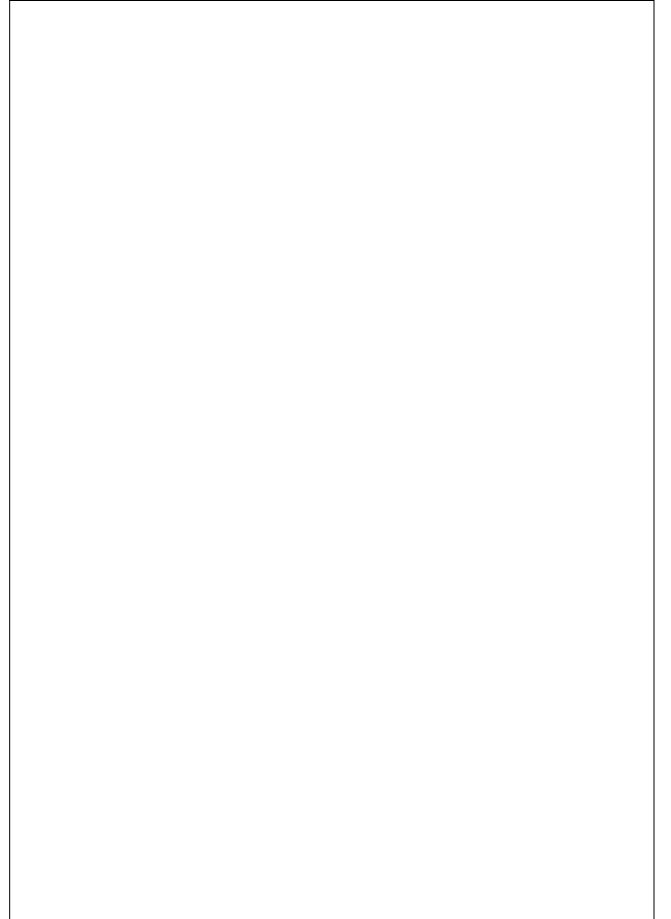



Scene	Duration	Panel	Duration
082	12:23	8	01:07

NO PANEL

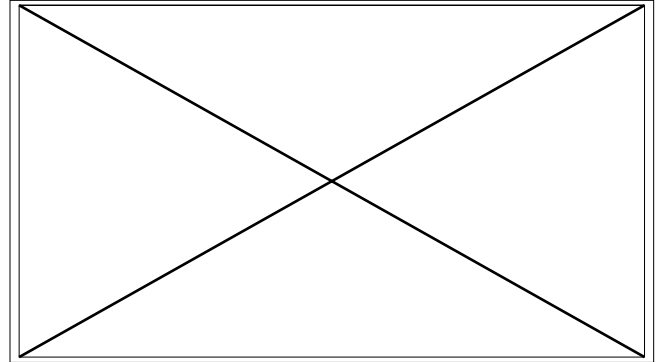
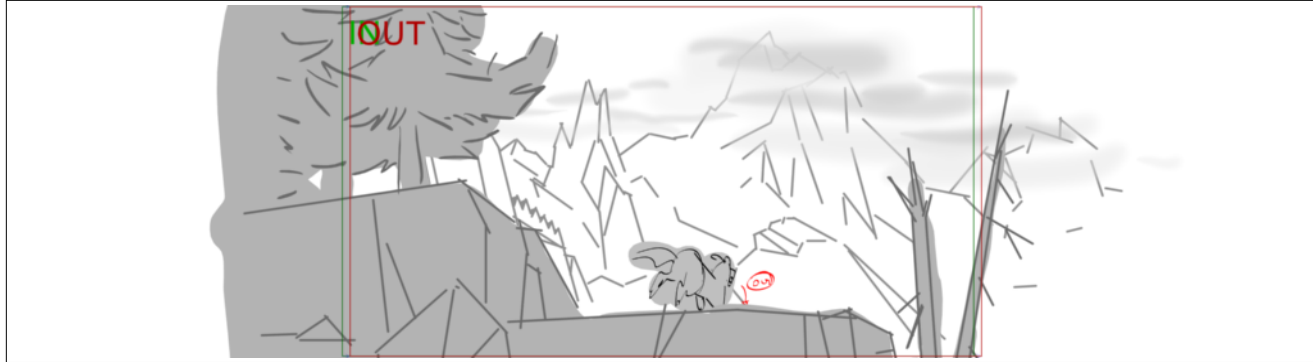

**Dialogue**  
 54. SÉBASTIEN (trouve qu'elle joue sur les mots)  
 A nous trois si tu préfères !

**Action Notes**  
 BELLE le suit OUT

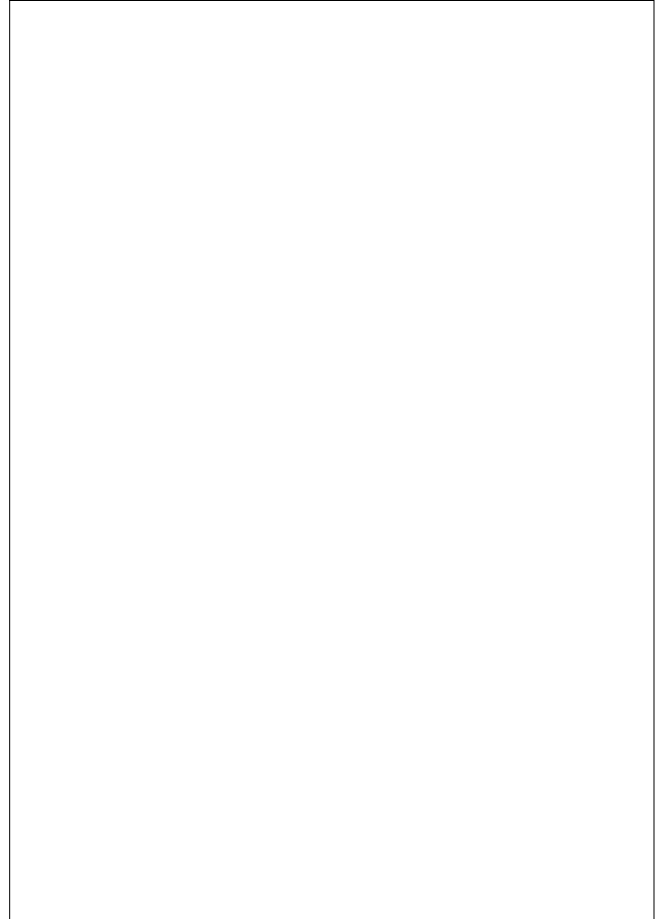



Scene	Duration	Panel	Duration
082	12:23	9	00:21

Scene	Duration	Panel	Duration
083	02:12	1	00:12

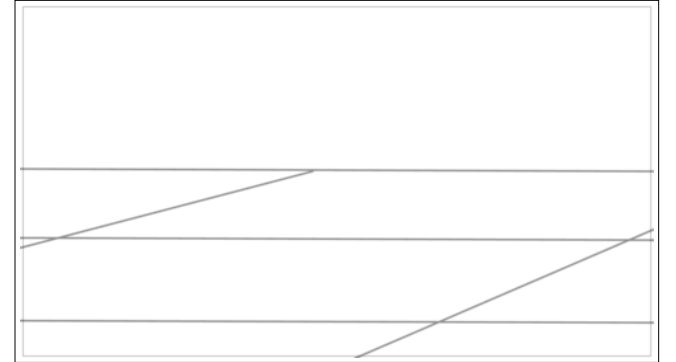
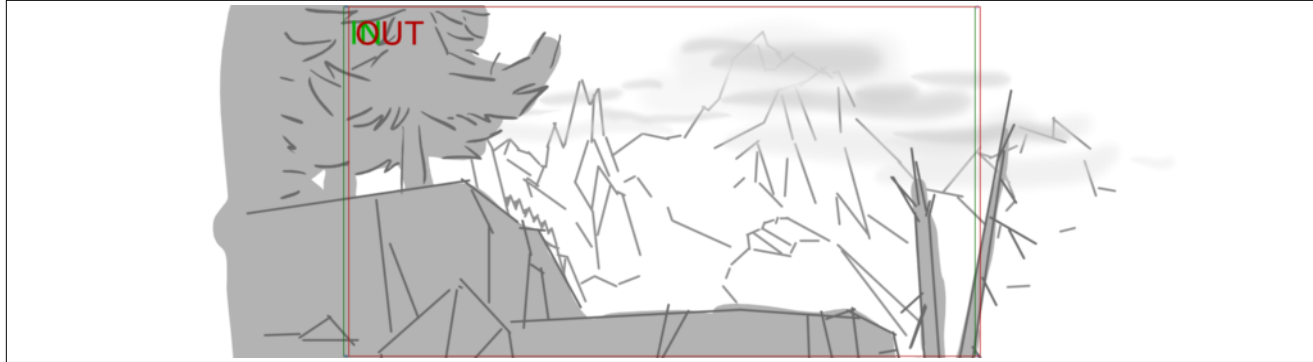

**Dialogue**

54. SÉBASTIEN (trouve qu'elle joue sur les mots)  
A nous trois si tu préfères !

**Action Notes**

11. INT - BASTIDE - JOUR

Scene	Duration	Panel	Duration
083	02:12	2	00:13

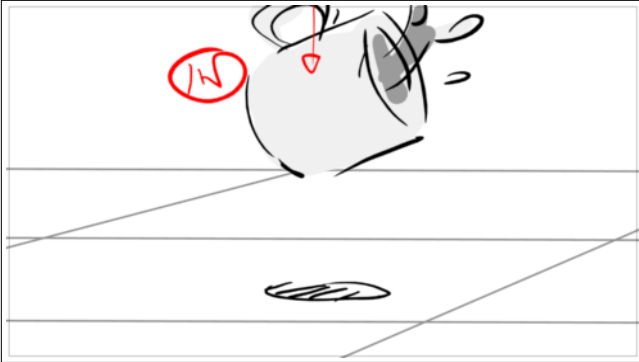

**Action Notes**

Mug de café tombe au sol

Scene	Duration	Panel	Duration
083	02:12	3	00:14

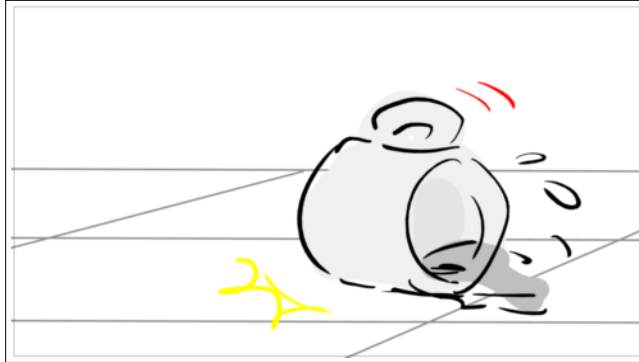

**Dialogue**

64. CÉSAR  
(bouillonne) Mais c'est pas vrai !

Scene	Duration	Panel	Duration
083	02:12	4	00:23



**Dialogue**

64. CÉSAR  
(bouillonne) Mais c'est pas vrai !

**Action Notes**

et roule

Scene	Duration	Panel	Duration
084	02:24	1	01:00

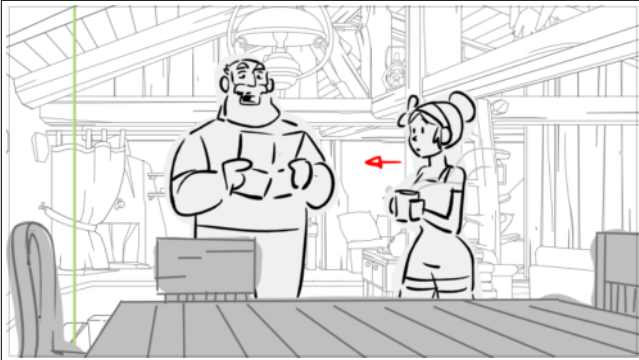

**Dialogue**  
 64. CÉSAR  
 Pourquoi il m'a pas écouté bon sang !

**Action Notes**  
 César estomaqué lettre de SEB en main

Scene	Duration	Panel	Duration
084	02:24	2	01:00



**Dialogue**  
 64. CÉSAR  
 Pourquoi il m'a pas écouté bon sang !

**Action Notes**  
 ANG lit par dessus son épaule

Scene	Duration	Panel	Duration
084	02:24	3	00:24

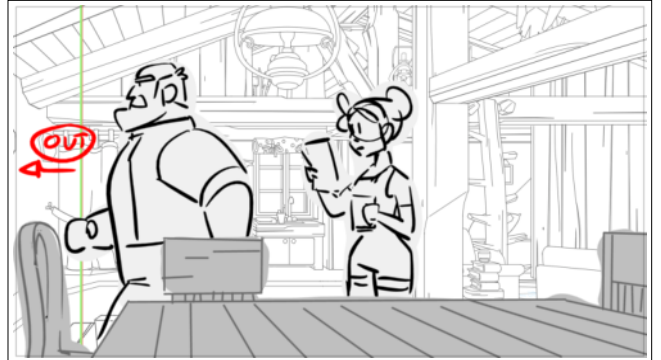

**Action Notes**  
 César OUT laissant la lettre à ANG



Scene	Duration	Panel	Duration
085	02:10	1	00:12

Scene	Duration	Panel	Duration
085	02:10	2	00:05

Scene	Duration	Panel	Duration
085	02:10	3	00:08

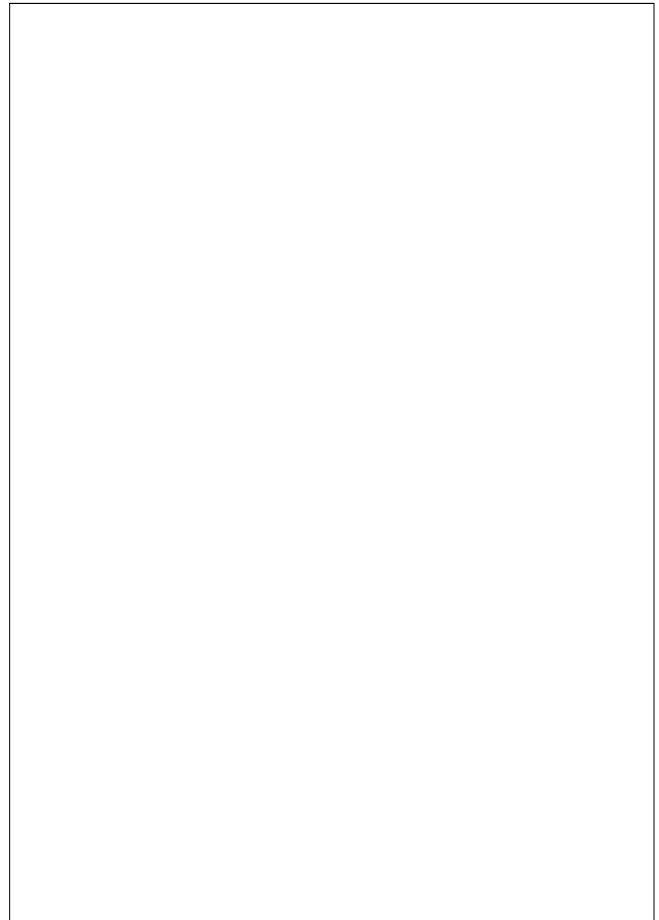
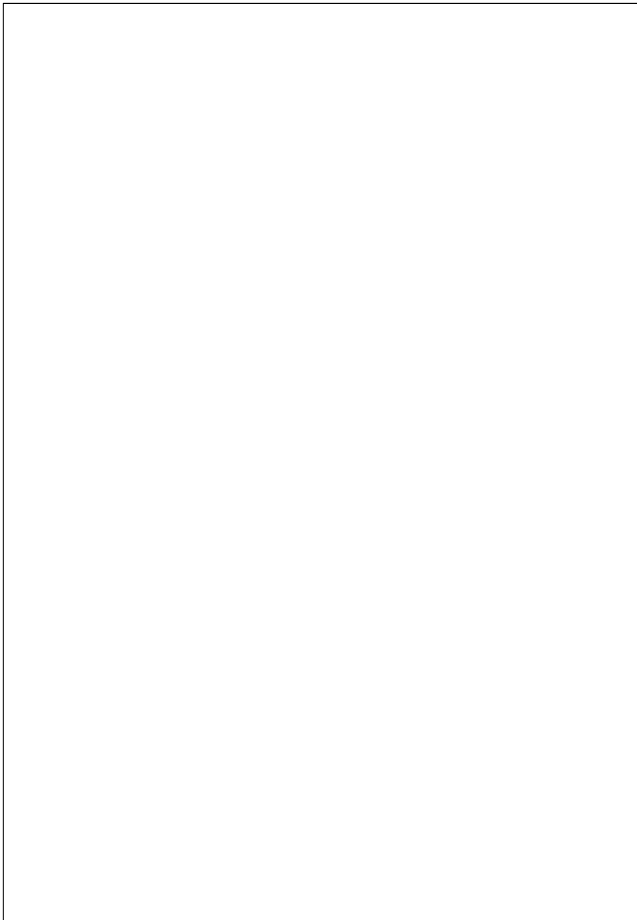
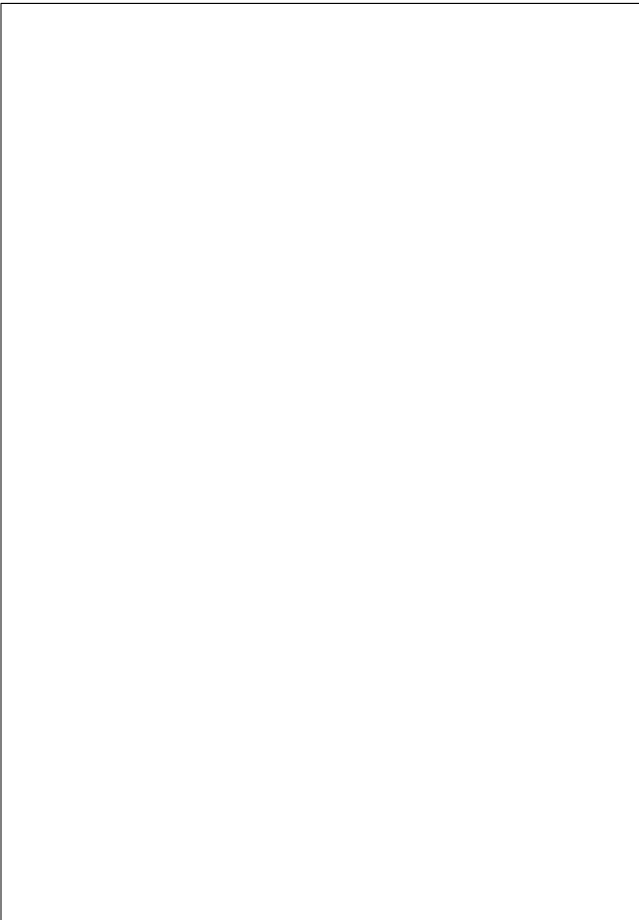

Scene	Duration	Panel	Duration
085	02:10	4	01:04

**Dialogue**

65. ANGELINA (inquiète)  
Tu ne vas pas y aller, quand même ?!

Scene	Duration	Panel	Duration
085	02:10	5	00:06

**Dialogue**

65. ANGELINA (inquiète)  
Tu ne vas pas y aller, quand même ?!

Scene	Duration	Panel	Duration
086	02:15	1	00:07



Scene	Duration	Panel	Duration
086	02:15	2	00:12



**Action Notes**

César UP sac à l'épaule et piolet en main

Scene	Duration	Panel	Duration
086	02:15	3	01:07



**Dialogue**

66. CÉSAR (déterminé)  
Il ne me laisse pas le choix !

Scene	Duration	Panel	Duration
086	02:15	4	00:14



**Dialogue**

66. CÉSAR (déterminé)  
Il ne me laisse pas le choix !

Scene	Duration	Panel	Duration
087	06:12	1	00:18

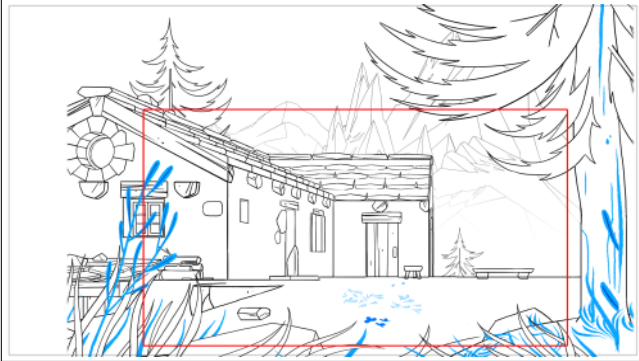

**Action Notes**

13. EXT - BASTIDE - JOUR

Scene	Duration	Panel	Duration
087	06:12	2	01:00

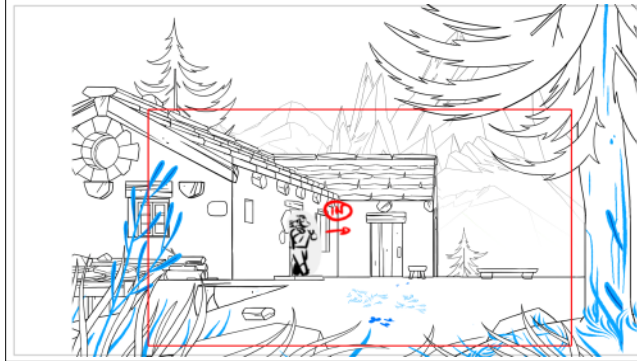

**Action Notes**

Cesar IN

Scene	Duration	Panel	Duration
087	06:12	3	01:00

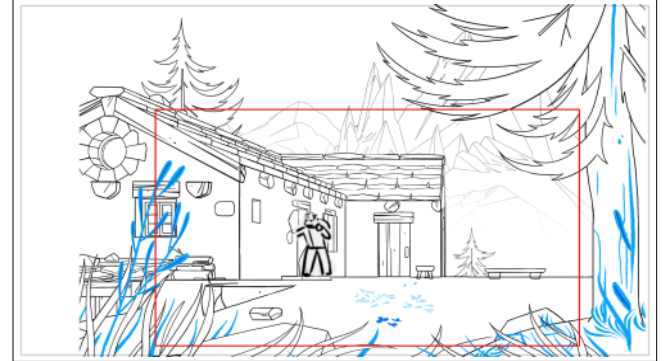

**Action Notes**

ferme la porte de la Bastide



Scene	Duration	Panel	Duration
087	06:12	4	01:00

Scene	Duration	Panel	Duration
087	06:12	5	01:11

Scene	Duration	Panel	Duration
087	06:12	6	01:08

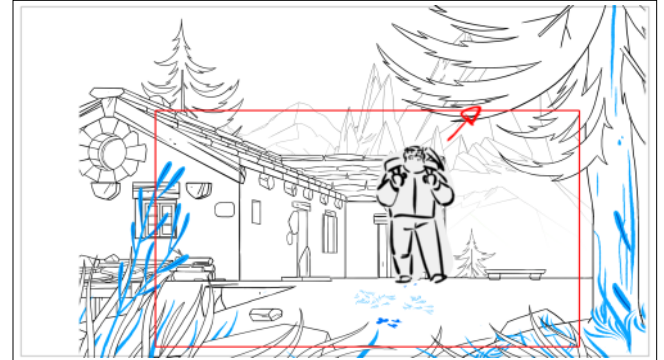
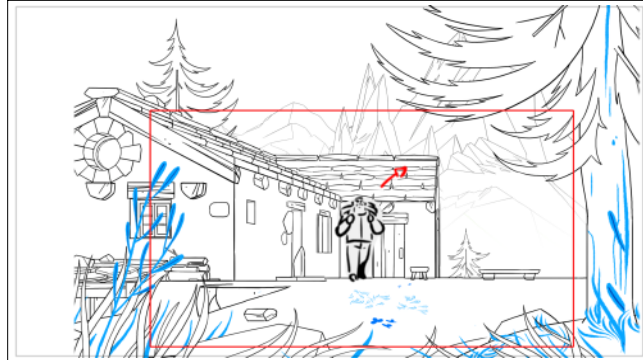
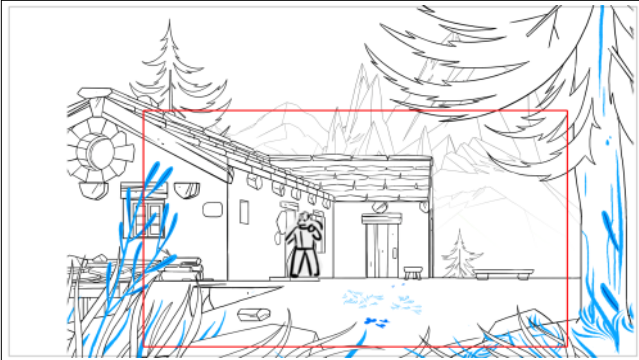

**Action Notes**

ferme la porte de la Bastide

Scene	Duration	Panel	Duration
088	03:22	1	00:09

Scene	Duration	Panel	Duration
088	03:22	2	01:13

Scene	Duration	Panel	Duration
088	03:22	3	00:10



**Dialogue**  
SFX OUVERTURE ET FERMETURE DE PORTE

Scene	Duration	Panel	Duration
088	03:22	4	00:10



**Dialogue**  
 PU ANGELINA  
 César attends! (ou Papa attends?)

Scene	Duration	Panel	Duration
088	03:22	5	01:05



Scene	Duration	Panel	Duration
089	01:12	1	00:15



**Dialogue**  
 69. ANGELINA  
 Je viens avec toi !

Scene	Duration	Panel	Duration
089	01:12	2	00:22



**Dialogue**  
 69. ANGELINA  
 Je viens avec toi !

Scene	Duration	Panel	Duration
090	03:08	1	00:08



**Dialogue**  
 70. CÉSAR (surpris)  
 Quoi ??

Scene	Duration	Panel	Duration
090	03:08	2	01:00



**Dialogue**  
 70. CÉSAR (surpris)  
 Non, non, non Angelina,

Scene	Duration	Panel	Duration
090	03:08	3	00:17



**Dialogue**  
 70. CÉSAR (surpris)  
 c'est trop dangereux.

Scene	Duration	Panel	Duration
090	03:08	4	01:05



**Dialogue**  
 71. ANGELINA  
 Raison de plus !

Scene	Duration	Panel	Duration
090	03:08	5	00:03



**Dialogue**  
 71. ANGELINA  
 Raison de plus !

Scene	Duration	Panel	Duration
091	04:06	1	00:02



**Dialogue**

71. ANGELINA

C'est toi qui répète toujours : "règle numéro un en alpinisme..."

Scene	Duration	Panel	Duration
091	04:06	2	01:12



**Dialogue**

71. ANGELINA

C'est toi qui répète toujours : "règle numéro un en alpinisme..."

Scene	Duration	Panel	Duration
091	04:06	3	01:02



**Dialogue**

71. ANGELINA

C'est toi qui répète toujours : "règle numéro un en alpinisme..."

Scene	Duration	Panel	Duration
091	04:06	4	01:15



**Dialogue**  
 72. CÉSAR (complète lui-même)  
 ...ne jamais partir seul".

Scene	Duration	Panel	Duration
092	05:12	1	00:20



**Dialogue**  
 72. CÉSAR  
 Tu as raison...

Scene	Duration	Panel	Duration
092	05:12	2	01:20



**Dialogue**  
 72. CÉSAR  
 Allons !

Scene	Duration	Panel	Duration
092	05:12	3	02:10

Scene	Duration	Panel	Duration
092	05:12	4	00:12

NO PANEL

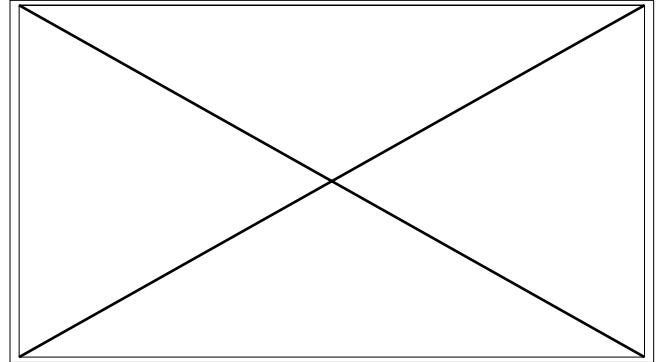
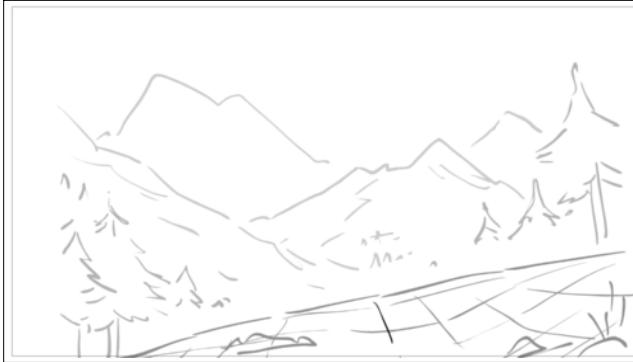

**Dialogue**  
 72. CÉSAR  
 Il ne faut pas traîner !





Scene	Duration	Panel	Duration
093	03:12	1	03:12

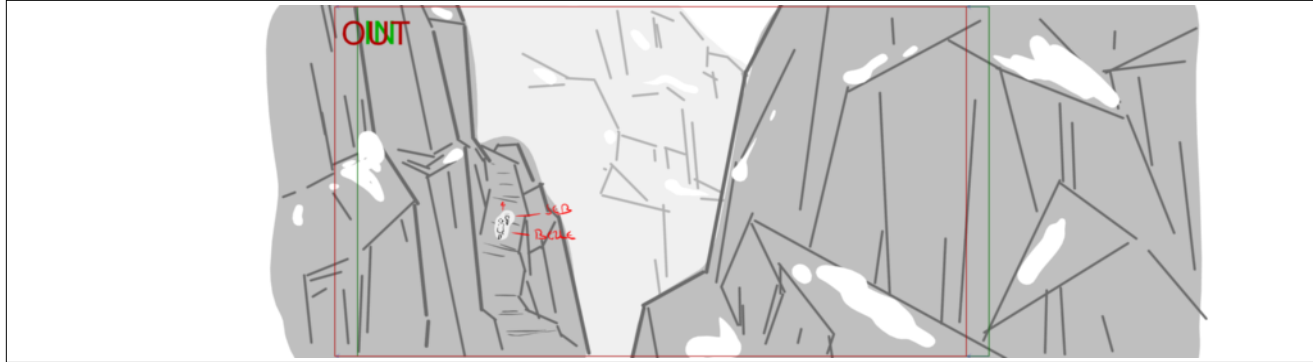

**Action Notes**

12. EXT - PIC SANS NOM, HAUTE ALTITUDE - JOUR  
BG partiellement enneigé SEB et BELLE avancent

Scene	Duration	Panel	Duration
094	02:09	1	02:09



**Action Notes**

BG partiellement enneigé  
SEB et BELLE avancent



Scene	Duration	Panel	Duration
095	02:13	1	00:07

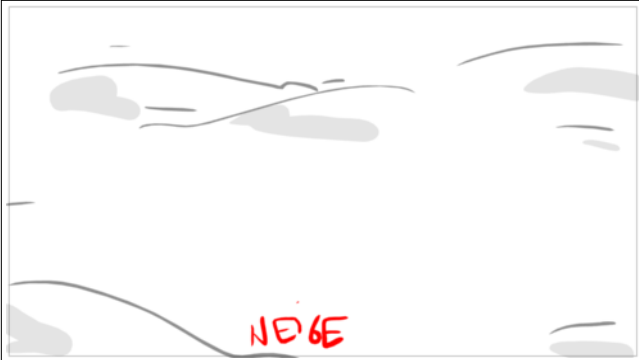

Action Notes  
CLOSE UP NEIGE

Scene	Duration	Panel	Duration
095	02:13	2	00:06



Action Notes  
BOTTE DE SEB IN+ CRAMPONS

Scene	Duration	Panel	Duration
095	02:13	3	00:06



Action Notes

Scene	Duration	Panel	Duration
095	02:13	4	00:06



Scene	Duration	Panel	Duration
095	02:13	5	00:06



**Action Notes**

laisse une trace dans la neige

Scene	Duration	Panel	Duration
095	02:13	6	00:07



Scene	Duration	Panel	Duration
095	02:13	7	00:07

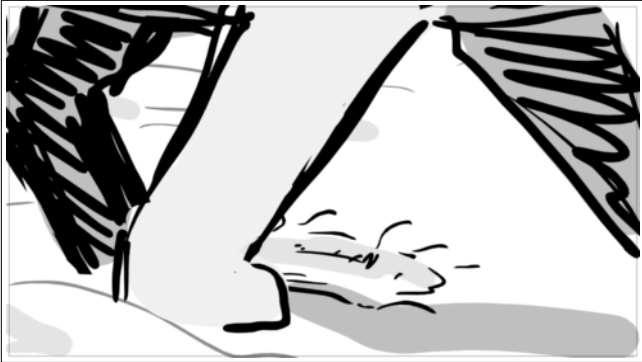

Scene	Duration	Panel	Duration
095	02:13	8	00:06

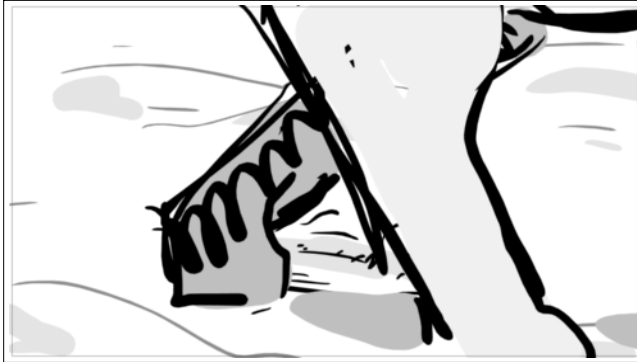

Scene	Duration	Panel	Duration
095	02:13	9	00:06

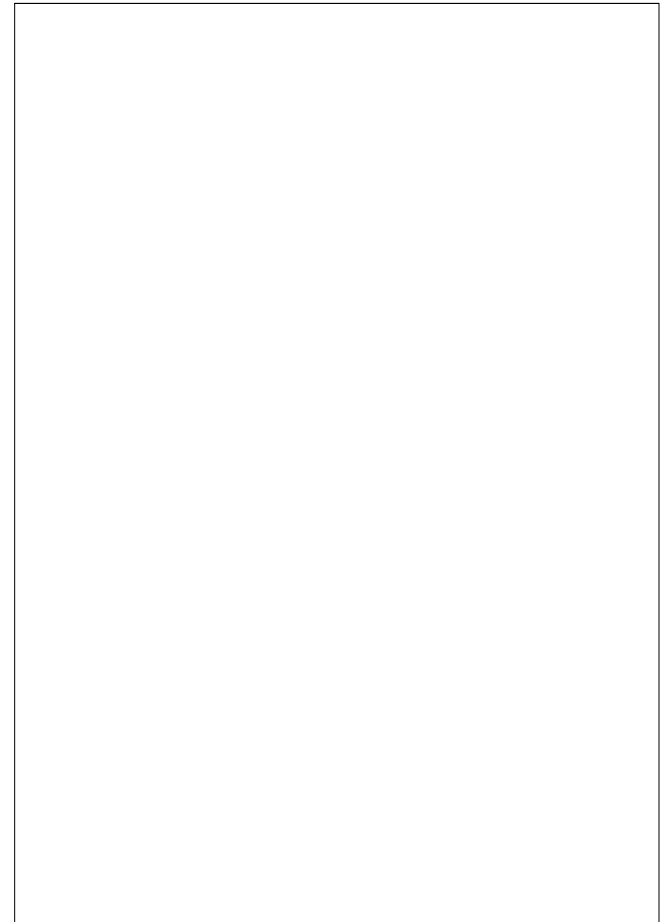
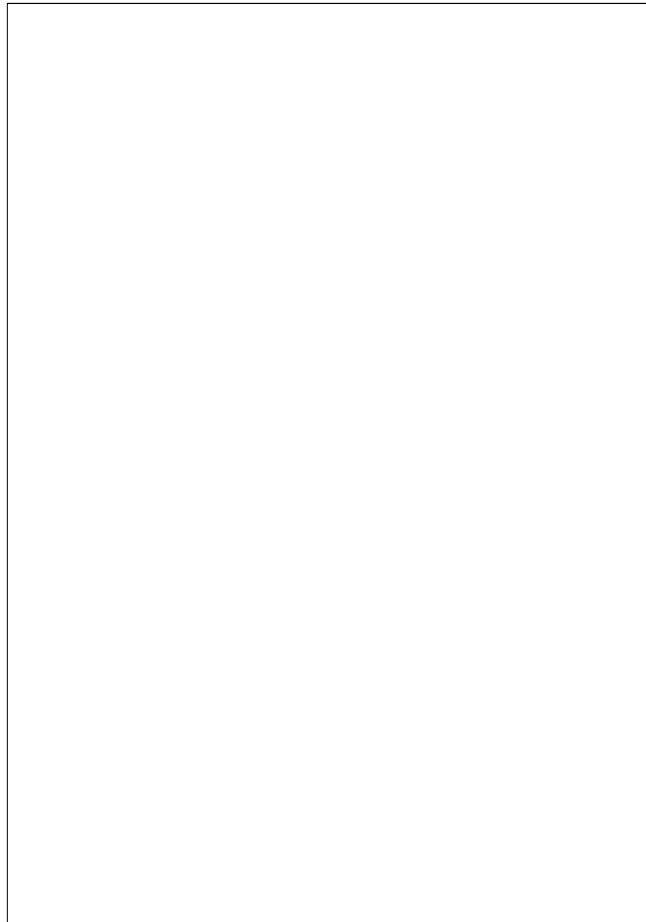
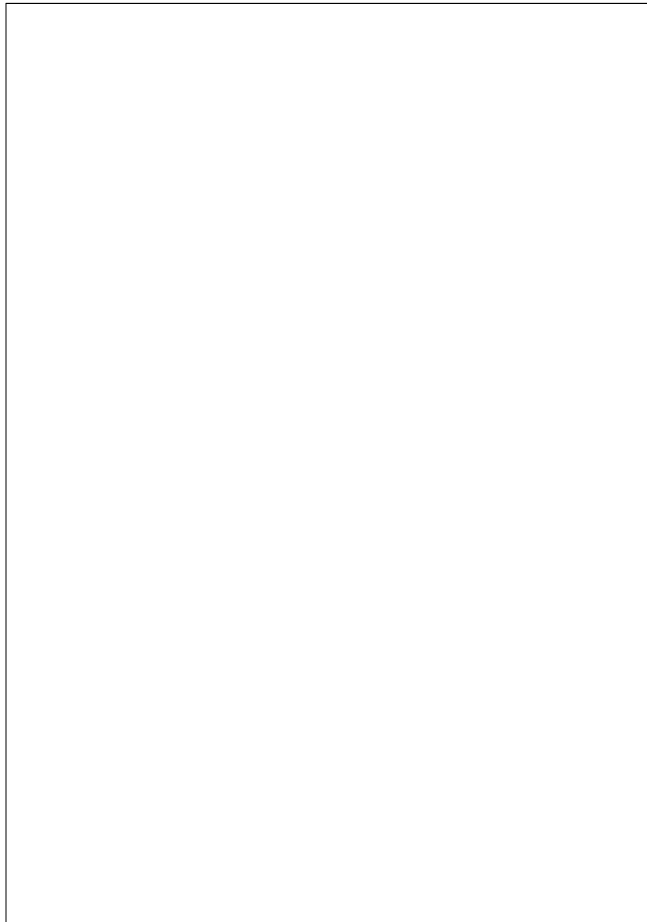

Scene	Duration	Panel	Duration
095	02:13	10	00:06



Scene	Duration	Panel	Duration
096	01:21	1	01:21



**Action Notes**

FX condensation sort de la bouche de seb et Belle

NO PANEL

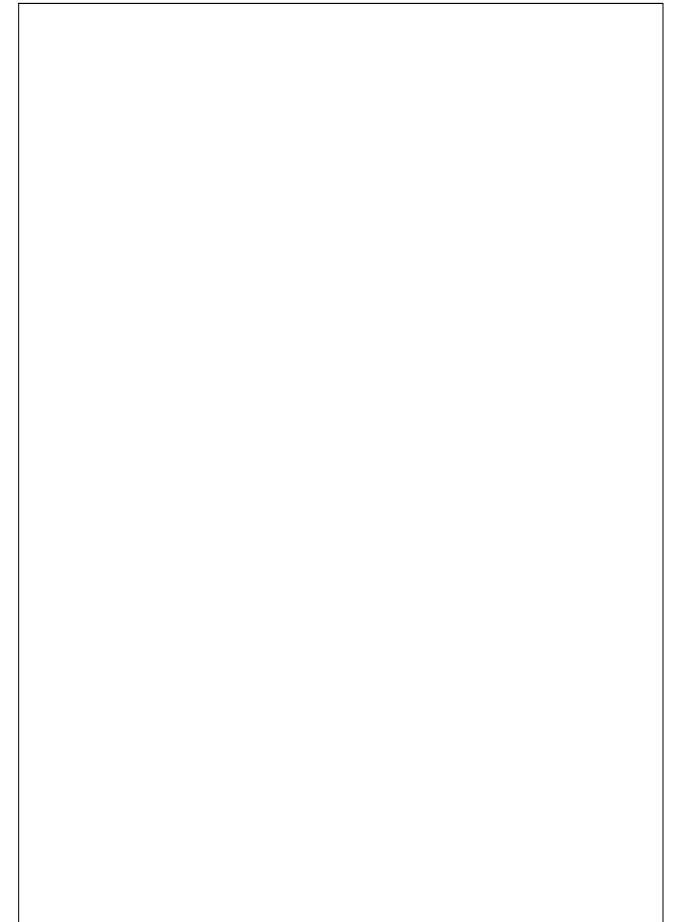
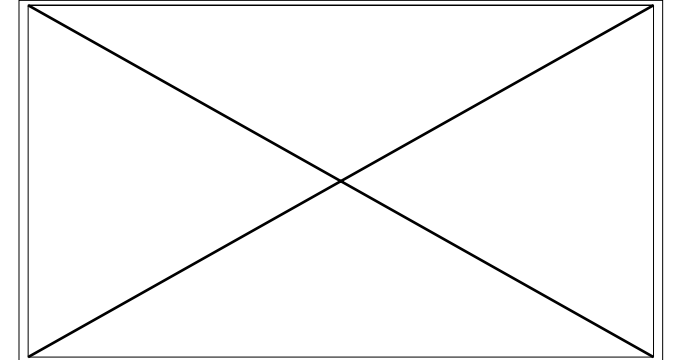

Scene	Duration	Panel	Duration
097	03:12	1	03:12

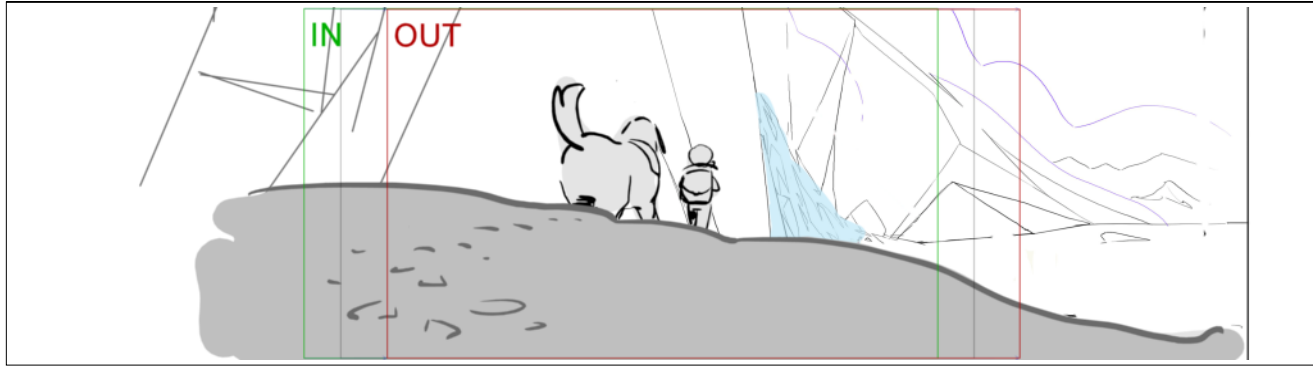

**Action Notes**

PAN FOLLOW  
 SEB et BELLE arrivent à la goulotte de glace

Scene	Duration	Panel	Duration
098	03:01	1	00:10

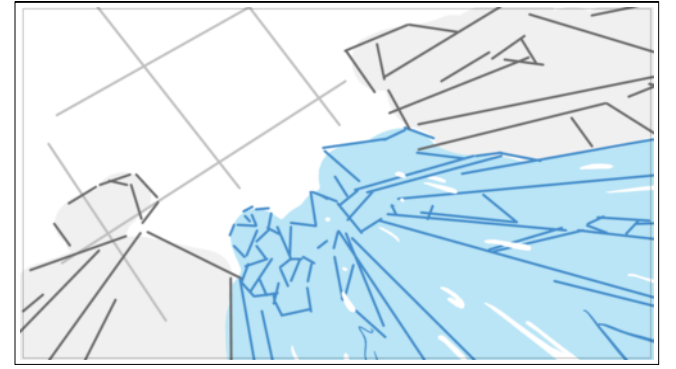

**Action Notes**

DOWNSHOT Pied de la goulotte

Scene	Duration	Panel	Duration
098	03:01	2	02:16

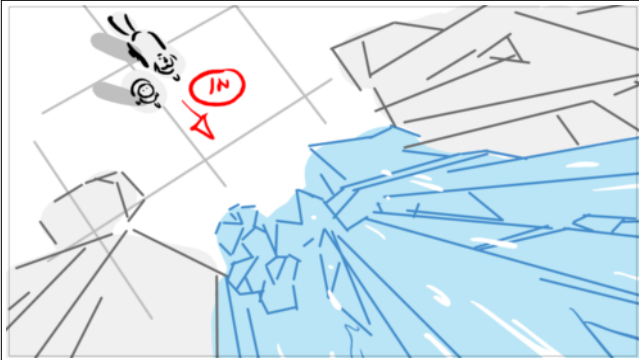

Scene	Duration	Panel	Duration
099	03:06	1	00:06

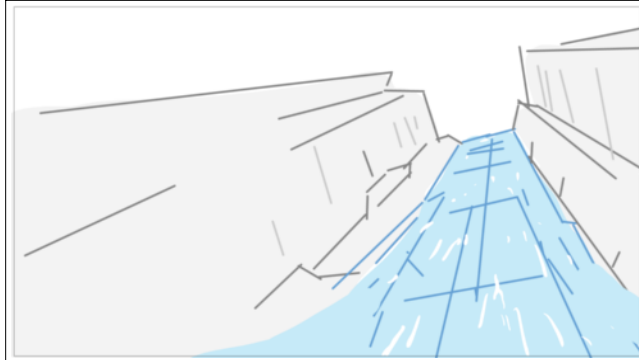

**Action Notes**

UPSHOT GOULOTTE

Scene	Duration	Panel	Duration
099	03:06	2	01:09

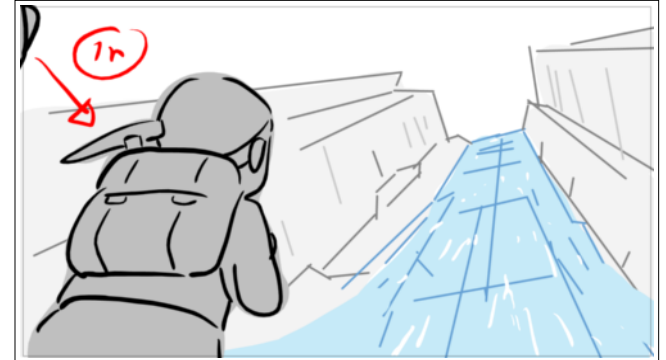

**Dialogue**

62. SÉBASTIEN  
on passe en style « alpi » maintenant.

Scene	Duration	Panel	Duration
099	03:06	3	00:18

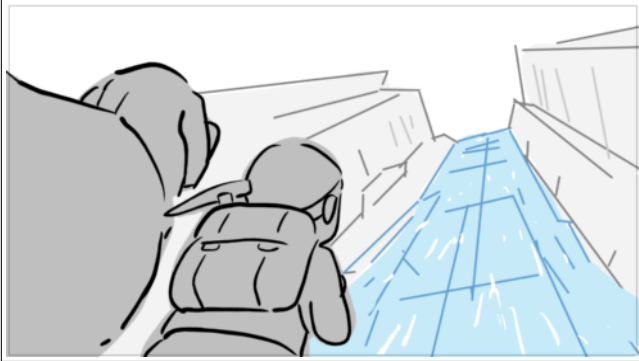

Scene	Duration	Panel	Duration
099	03:06	4	00:11



**Dialogue**

BELLE ABOIE

Scene	Duration	Panel	Duration
099	03:06	5	00:12

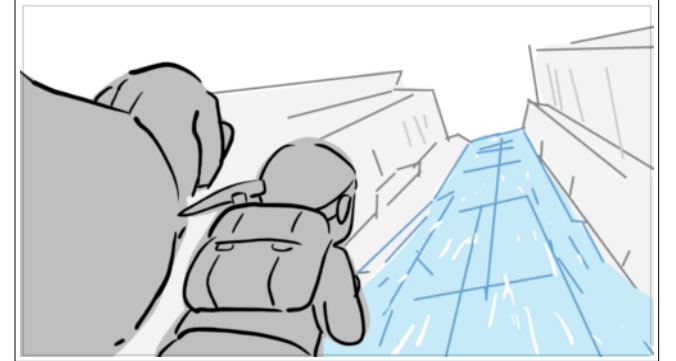



Scene	Duration	Panel	Duration
099_A	02:00	1	01:00

Scene	Duration	Panel	Duration
099_A	02:00	2	01:00

Scene	Duration	Panel	Duration
099_B	02:00	1	01:00

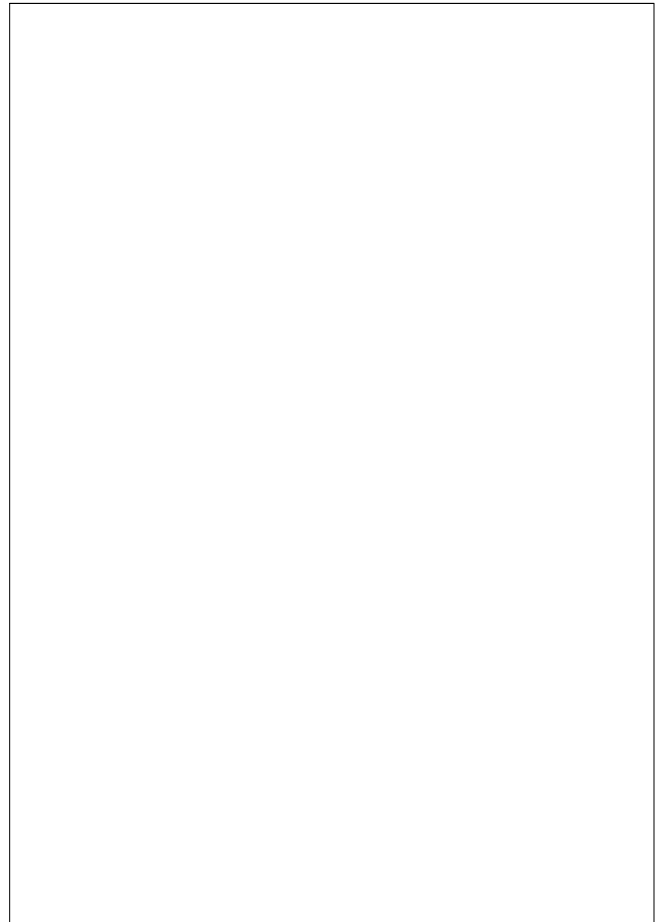
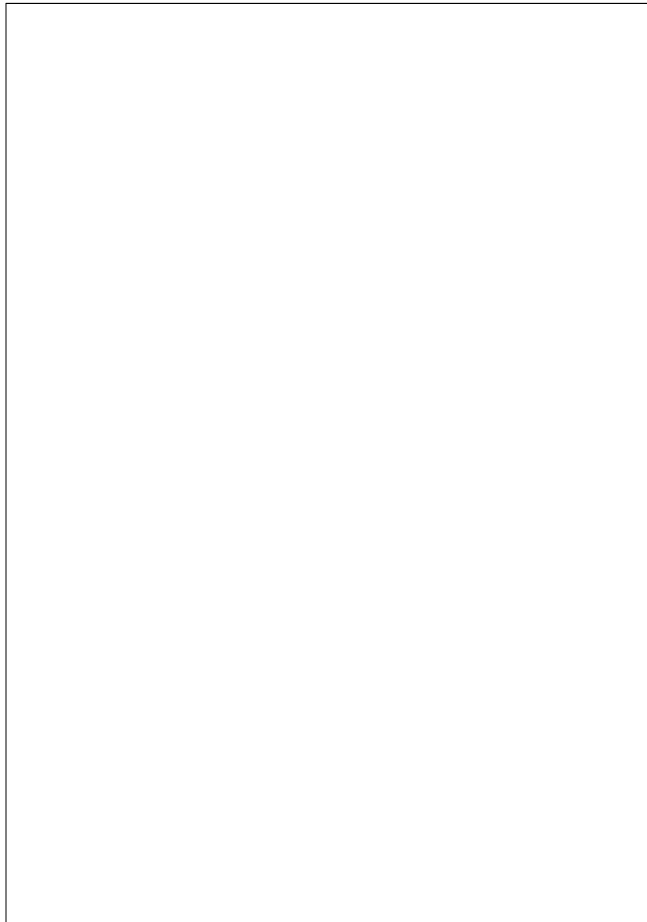

Scene	Duration	Panel	Duration
099_B	02:00	2	01:00



**Action Notes**

SEB OUT derrière OL ROCHER

Scene	Duration	Panel	Duration
100	01:16	1	00:09

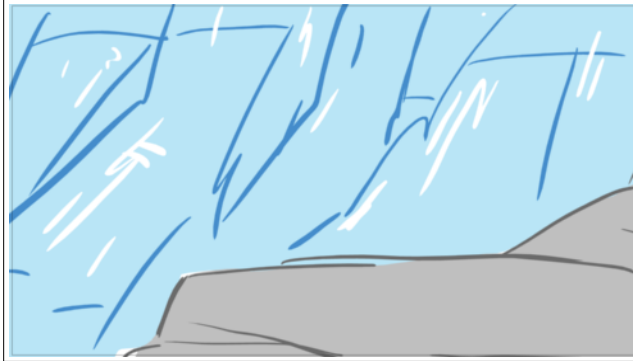

Scene	Duration	Panel	Duration
100	01:16	2	00:14

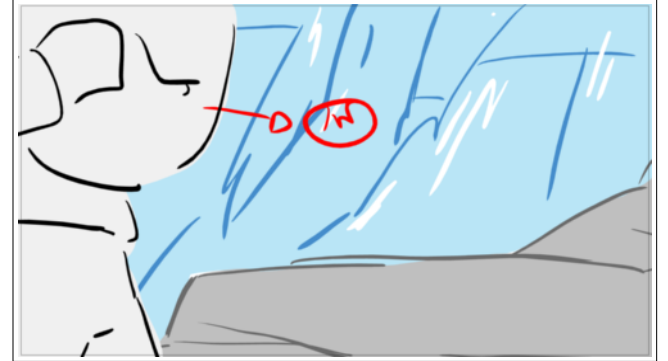

Scene	Duration	Panel	Duration
100	01:16	3	00:18



**Dialogue**

63. SÉBASTIEN  
.Allez,

**Action Notes**

SEB IN pose son sac sur un rocher

Scene	Duration	Panel	Duration
101	03:06	1	00:12



**Dialogue**

63. SÉBASTIEN  
c'est parti !

**Action Notes**

SEB fouille dans son sac

Scene	Duration	Panel	Duration
101	03:06	2	00:16



**Dialogue**

63. SÉBASTIEN  
c'est parti !

**Action Notes**

en sort les cordes

Scene	Duration	Panel	Duration
101	03:06	3	00:11



**Dialogue**  
63. SÉBASTIEN  
c'est parti !

Scene	Duration	Panel	Duration
101	03:06	4	00:16



**Dialogue**  
63. SÉBASTIEN  
c'est parti !

**Action Notes**  
puis le piolet

Scene	Duration	Panel	Duration
101	03:06	5	00:10



**Dialogue**  
63. SÉBASTIEN  
c'est parti !

Scene	Duration	Panel	Duration
101	03:06	6	00:16

Scene	Duration	Panel	Duration
102	06:00	1	00:18

NO PANEL

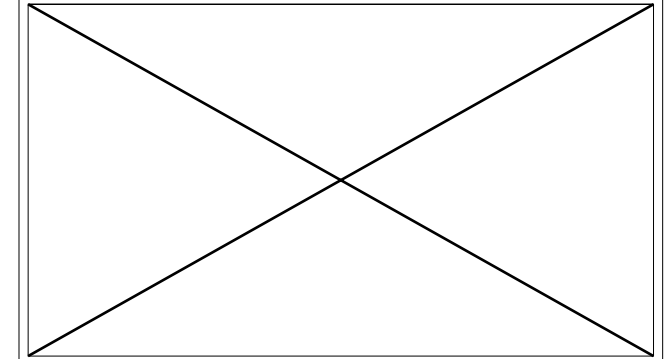
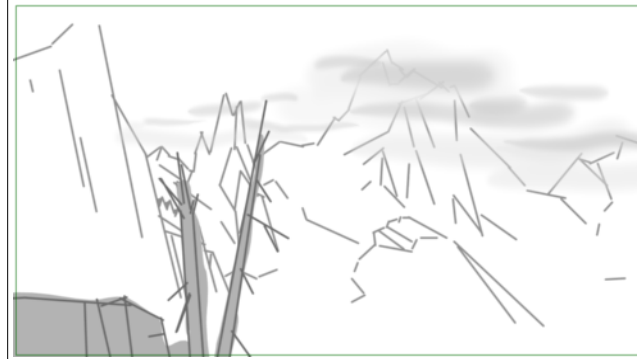

**Dialogue**  
 63. SÉBASTIEN  
 c'est parti !

**Action Notes**  
 15. EXT - PIC SANS NOM, BASSE ALTITUDE  
 - JOUR  
 ESTAB Pic sans nom

**Action Notes**  
 puis son casque

Scene	Duration	Panel	Duration
102	06:00	2	02:05

NO PANEL

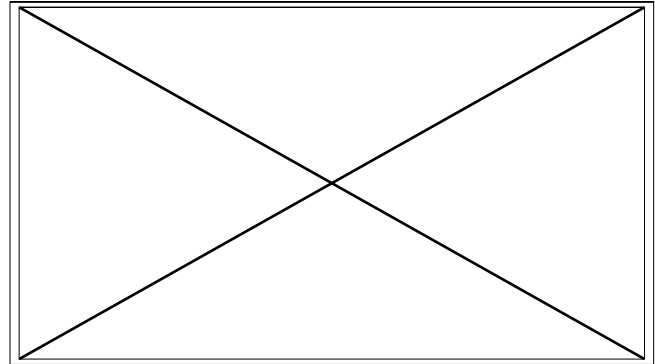
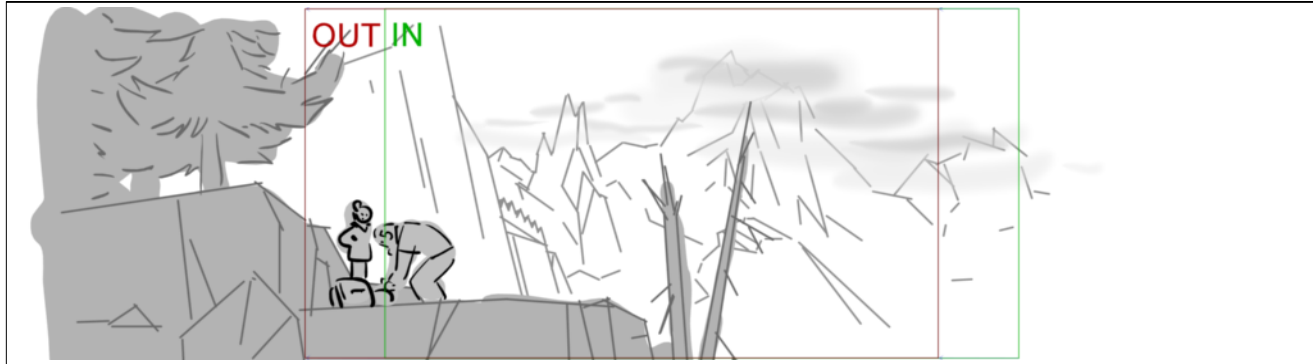

**Dialogue**  
 79. ANGELINA  
 (étonnée) On s'arrête encore ?

**Action Notes**  
 PAN  
 César et Angelina arrêtés, sacs et matériel posés à terre. César en train de fouiller dans son sac

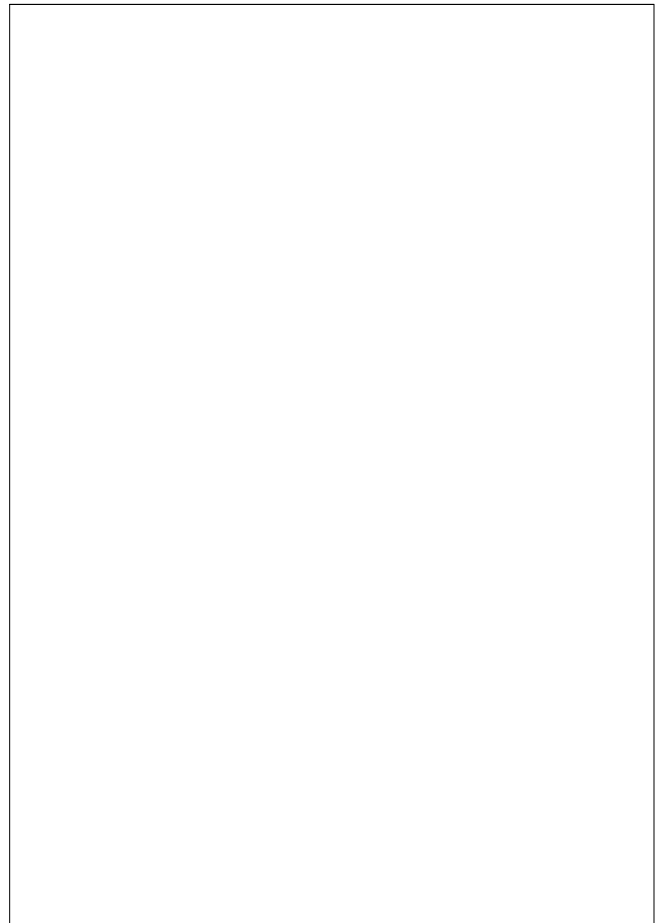

Scene	Duration	Panel	Duration
102	06:00	3	01:20



**Dialogue**

79. ANGELINA  
(étonnée) On s'arrête encore ?

**Action Notes**

César en sort une gourde

Scene	Duration	Panel	Duration
102	06:00	4	01:07



**Dialogue**

79. ANGELINA  
(étonnée) On s'arrête encore ?

**Action Notes**

et s'assied

Scene	Duration	Panel	Duration
103	05:02	1	00:14

**Dialogue**

79. ANGELINA

Je croyais qu'il fallait vite les retrouver.

Scene	Duration	Panel	Duration
103	05:02	2	01:10

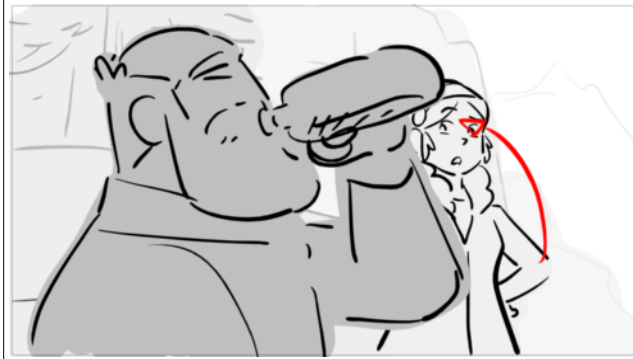
**Dialogue**

79. ANGELINA

Je croyais qu'il fallait vite les retrouver.

**Action Notes**

César boit

Scene	Duration	Panel	Duration
103	05:02	3	00:14

**Dialogue**

79. ANGELINA

Je croyais qu'il fallait vite les retrouver.

**Action Notes**

et s'essuie la bouche



Scene	Duration	Panel	Duration
103	05:02	4	02:14



**Dialogue**  
 80. CÉSAR  
 Si tu ne veux pas avoir le mal des montagnes, fais comme moi :

Scene	Duration	Panel	Duration
104	07:10	1	01:23



**Dialogue**  
 80. CÉSAR  
 des petites pauses régulières,

Scene	Duration	Panel	Duration
104	07:10	2	02:05



**Dialogue**  
 80. CÉSAR  
 et bois beaucoup. Sinon, on n'y arrivera pas.

**Action Notes**  
 César tend la gourde à Angelina

Scene	Duration	Panel	Duration
104	07:10	3	00:11



**Dialogue**  
81. ANGELINA  
Ok.

**Action Notes**  
A la saisit

Scene	Duration	Panel	Duration
104	07:10	4	01:00



**Action Notes**  
A boit

Scene	Duration	Panel	Duration
104	07:10	5	00:15



**Action Notes**  
A s'essuie la bouche

Scene	Duration	Panel	Duration
104	07:10	6	01:06



**Action Notes**

A s'assied à côté de César. Les deux contempelnt le pic sans nom

Scene	Duration	Panel	Duration
105	02:18	1	02:18

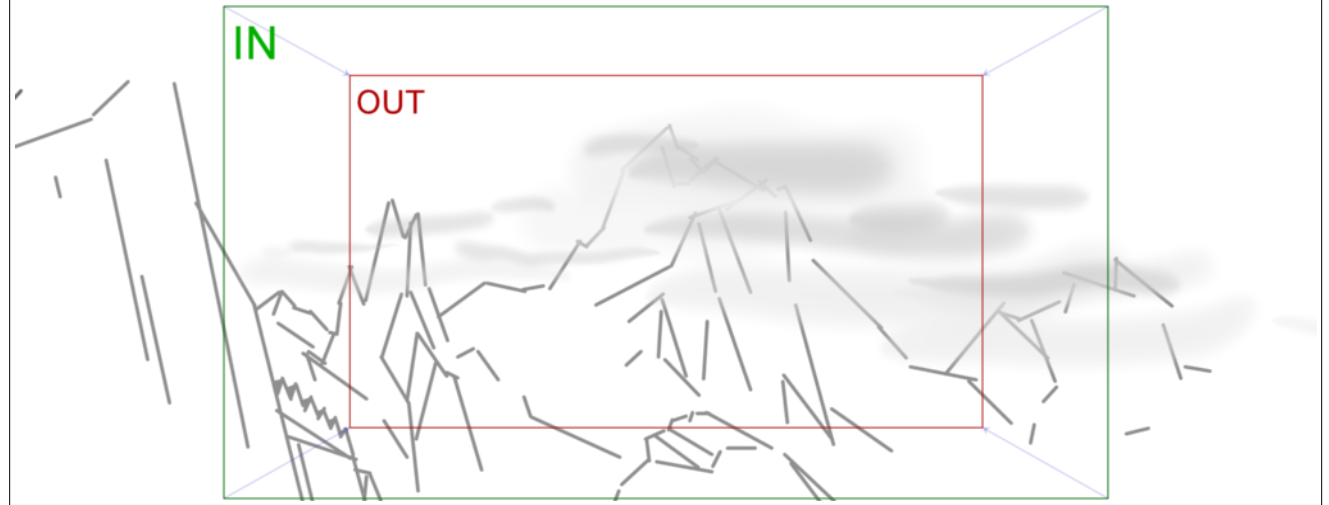

**Dialogue**

< soupir chargé d'émotion >.

**Action Notes**

TRK IN PIC sans nom

Scene	Duration	Panel	Duration
106	02:16	1	00:14



Scene	Duration	Panel	Duration
106	02:16	2	00:22

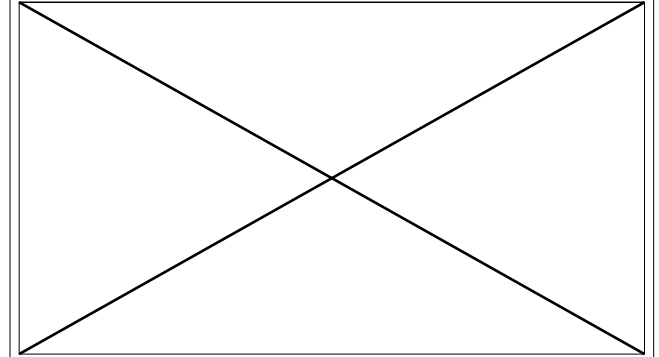

NO PANEL
----------

**Action Notes**

César plisse les yeux farouche

Scene	Duration	Panel	Duration
106	02:16	3	00:11

**Dialogue**

82. ANGELINA (lui pose la main sur l'épaule)  
Je sais...

**Action Notes**

TRK OUT  
Mai d'Angelina IN

Scene	Duration	Panel	Duration
106	02:16	4	00:19

**Dialogue**

82. ANGELINA (lui pose la main sur l'épaule)  
Je sais...

**Action Notes**

...se pose sur l'épaule de César

Scene	Duration	Panel	Duration
107	09:10	1	01:11



**Dialogue**

82. ANGELINA

Revenir là... Ça ne doit pas être facile...

Scene	Duration	Panel	Duration
107	09:10	2	02:20



**Dialogue**

82. ANGELINA

(émue) Je pense à Nino moi aussi.

**Action Notes**

César plisse les yeux à la CLINT EASTWOOD

Scene	Duration	Panel	Duration
107	09:10	3	01:04



**Dialogue**

83. CÉSAR

(reprend ses esprits) Mais on est là pour Sébastien et Belle...

Scene	Duration	Panel	Duration
107	09:10	4	00:12



**Dialogue**  
 83. CÉSAR  
 Allons-y !

**Action Notes**  
 César UP

Scene	Duration	Panel	Duration
107	09:10	5	00:12



**Dialogue**  
 83. CÉSAR  
 Allons-y !

**Action Notes**

Scene	Duration	Panel	Duration
107	09:10	6	00:24

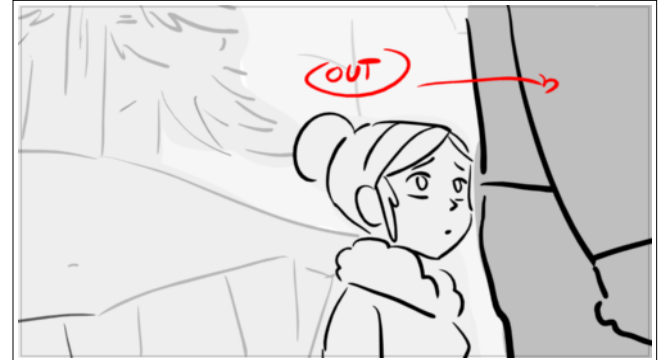

**Dialogue**  
 83. CÉSAR  
 Allons-y !

**Action Notes**  
 CESAR OUT

Scene	Duration	Panel	Duration
107	09:10	7	00:08



Scene	Duration	Panel	Duration
107	09:10	8	01:12

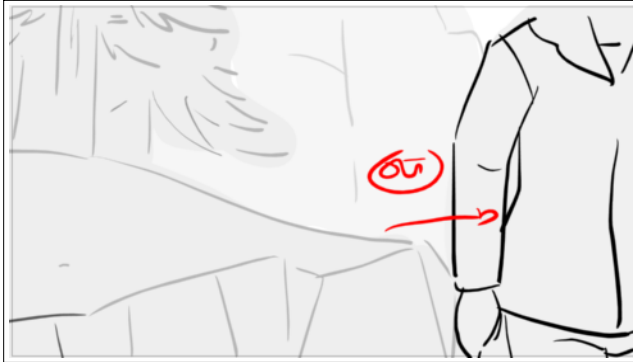

**Action Notes**  
ANG OUT

Scene	Duration	Panel	Duration
107	09:10	9	00:07





Scene	Duration	Panel	Duration
062_A	01:23	1	00:12

Scene	Duration	Panel	Duration
062_A	01:23	2	00:13

Scene	Duration	Panel	Duration
062_A	01:23	3	00:12

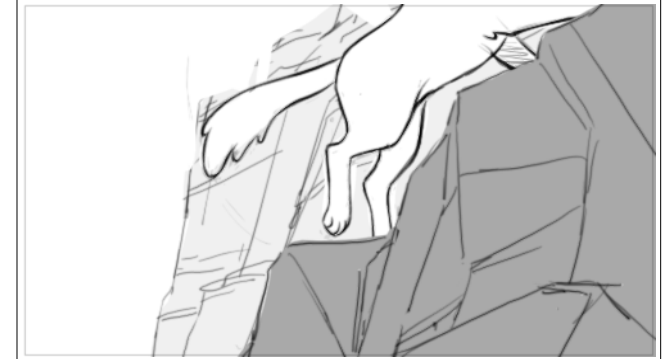

**Action Notes**

BELLE IN grimpe les rochers



Scene	Duration	Panel	Duration
062_A	01:23	4	00:11

Scene	Duration	Panel	Duration
108	05:22	1	00:24

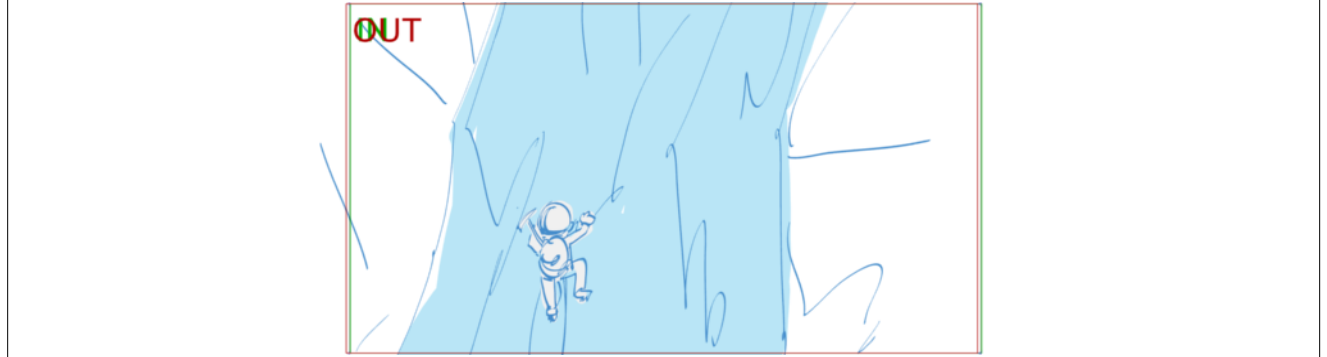
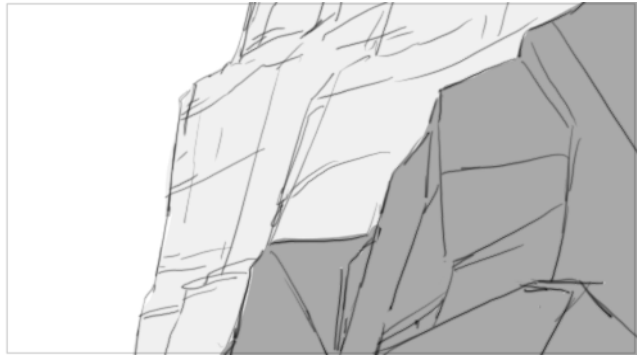

**Action Notes**

SEBASTIEN grimpe la goulotte de glace



Scene	Duration	Panel	Duration
108	05:22	1	00:24

NO PANEL

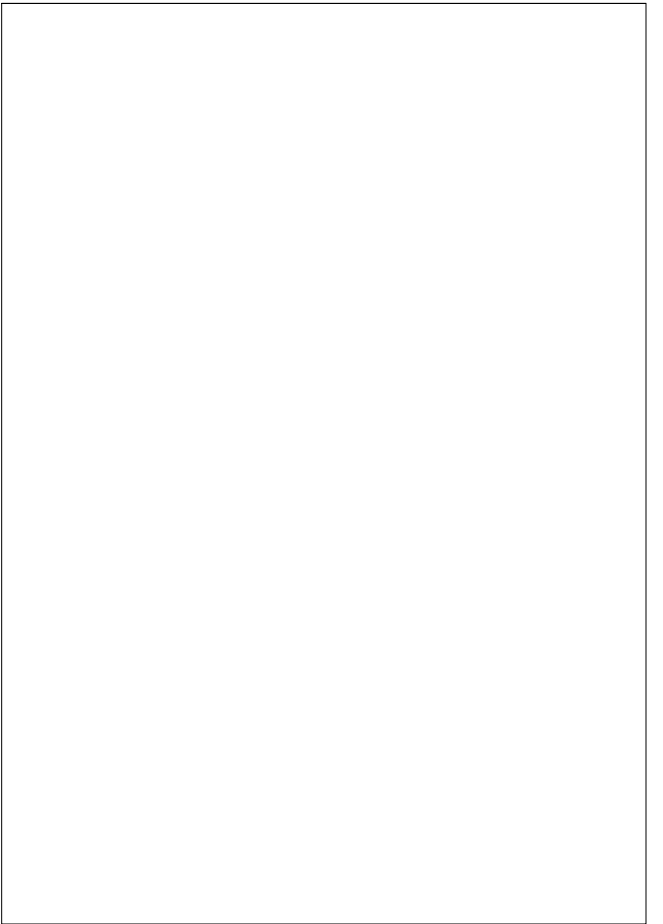
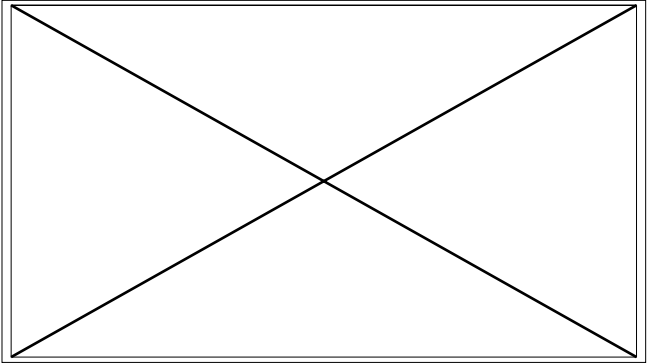
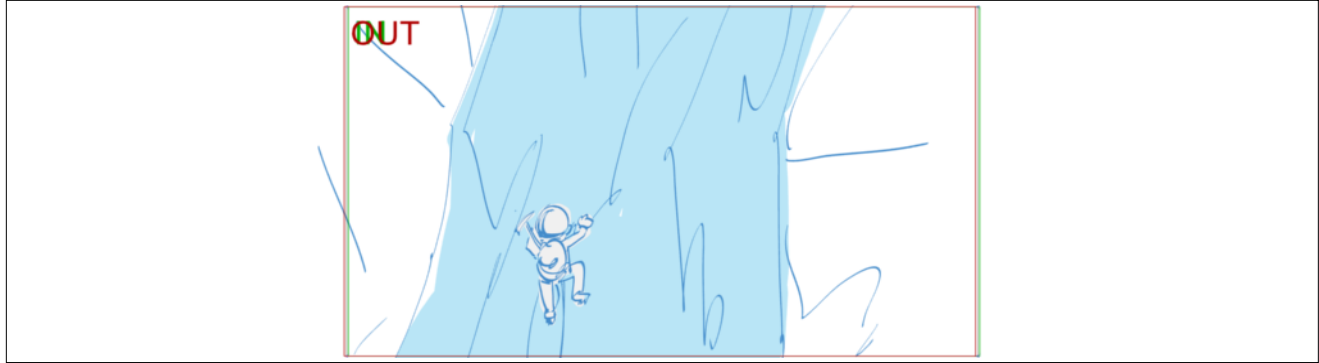



Scene	Duration	Panel	Duration
108	05:22	1	00:24

NO PANEL

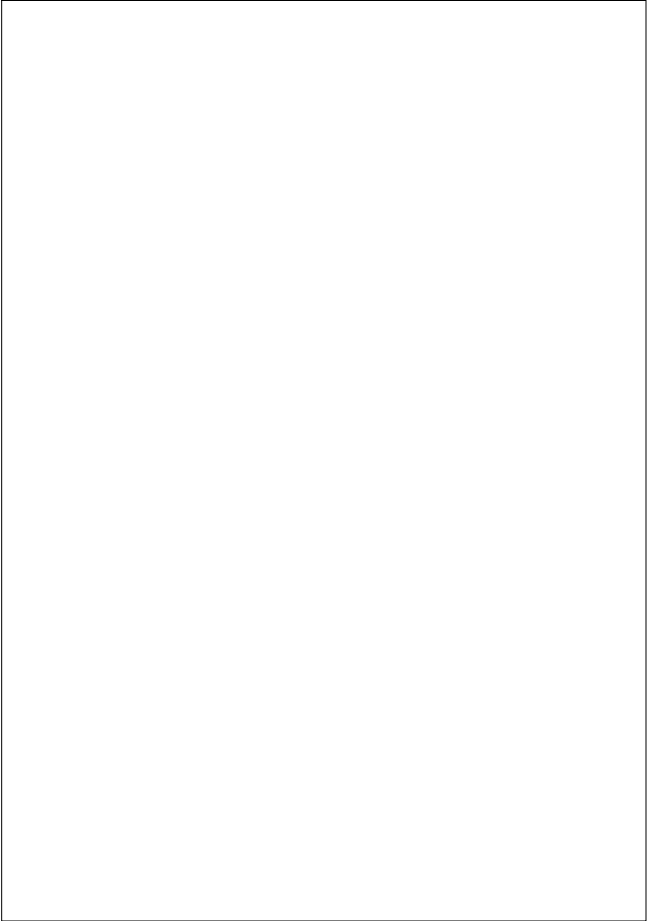
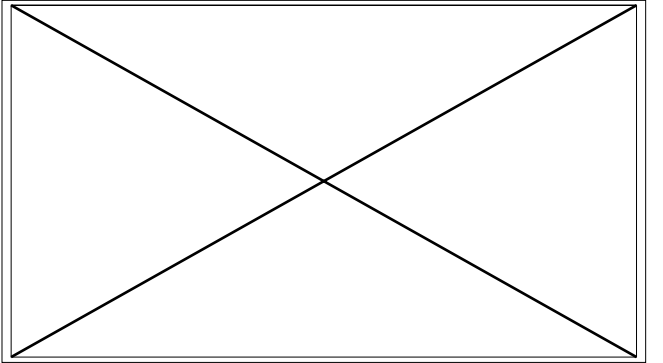
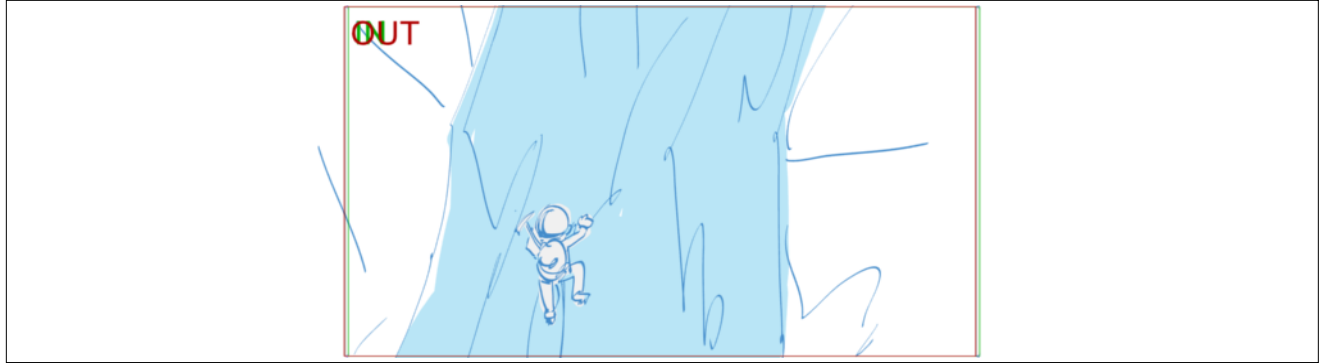



Scene	Duration	Panel	Duration
108	05:22	2	01:01

NO PANEL

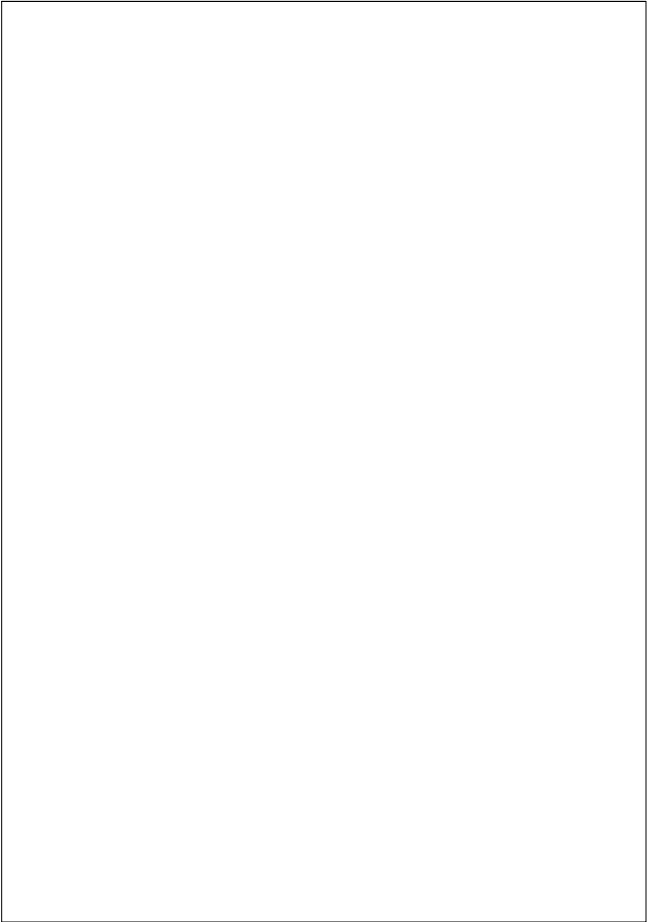
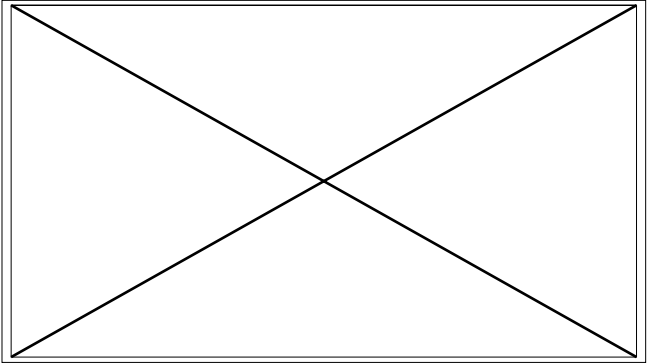
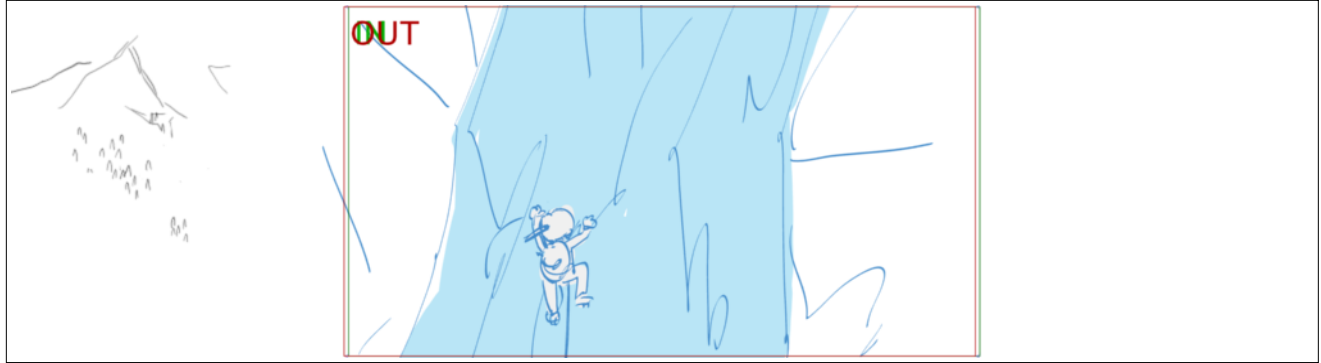



Scene	Duration	Panel	Duration
108	05:22	3	02:00

NO PANEL

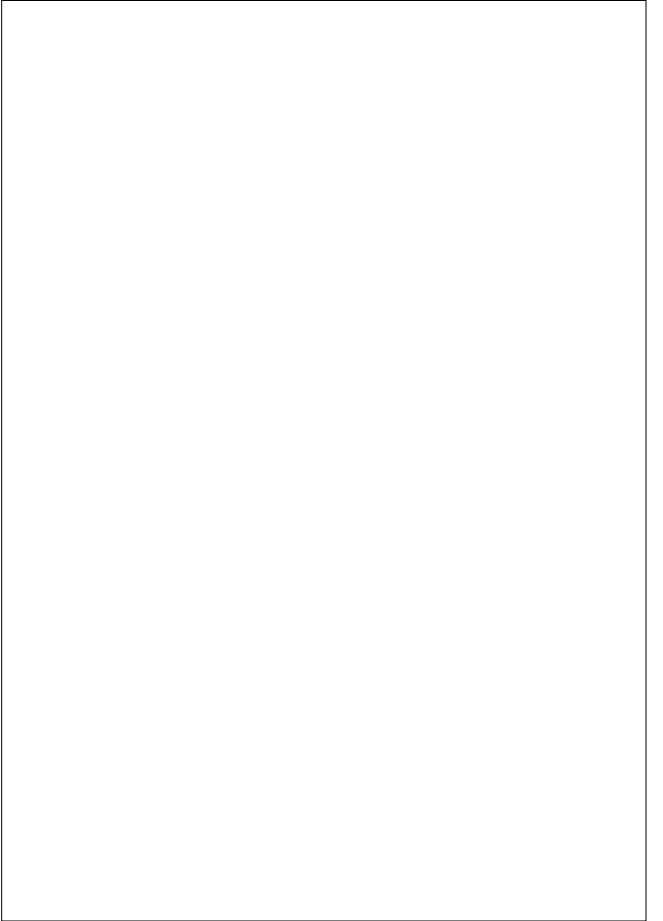
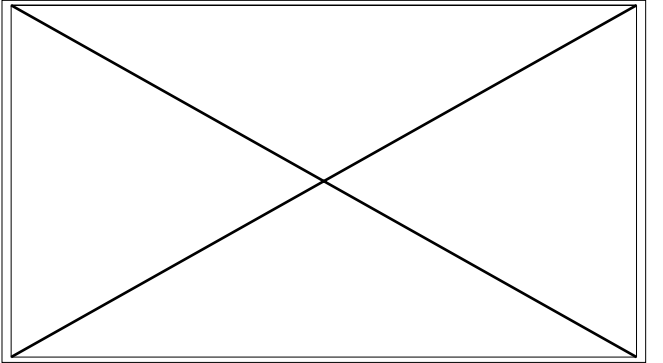
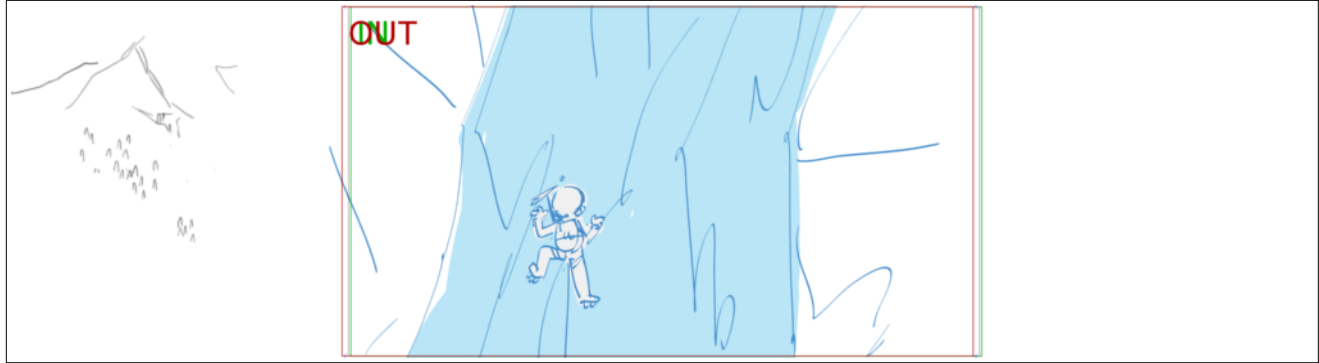



Scene	Duration	Panel	Duration
108	05:22	3	02:00

NO PANEL

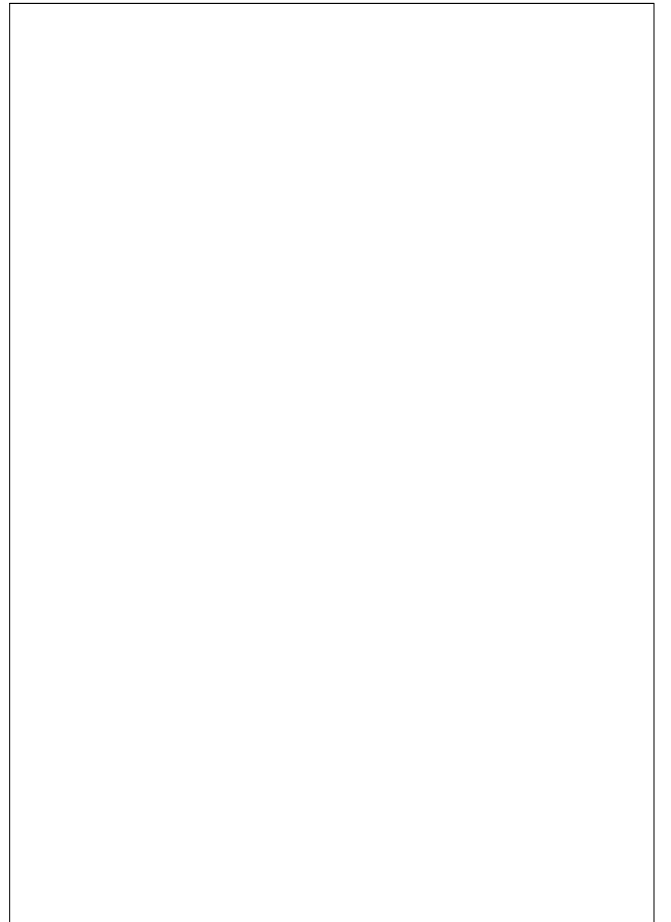
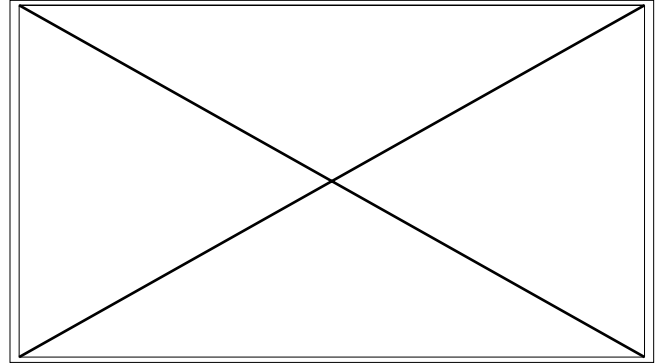
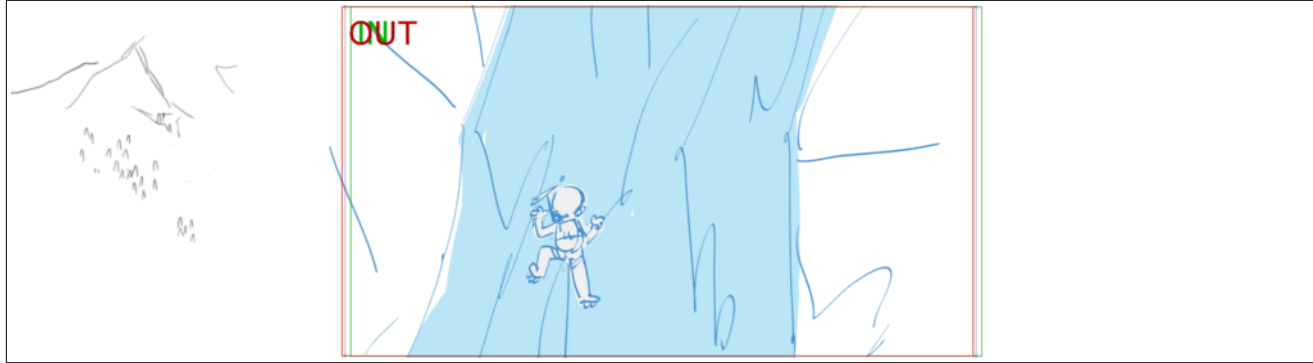



Scene	Duration	Panel	Duration
108	05:22	4	01:22

NO PANEL

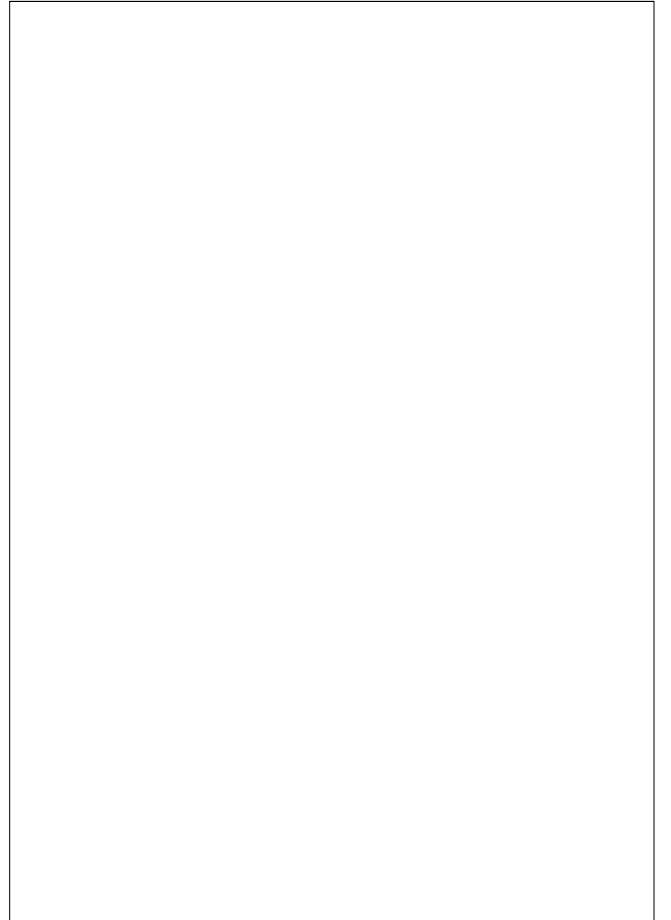
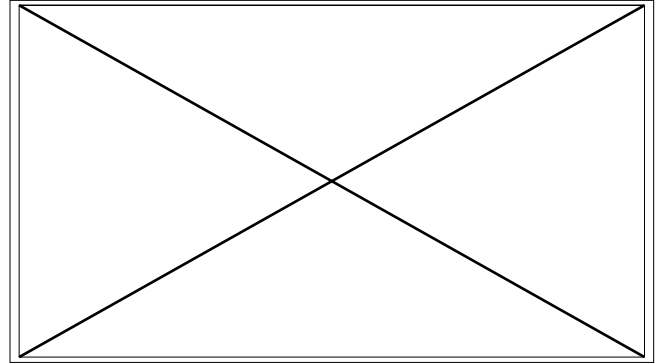
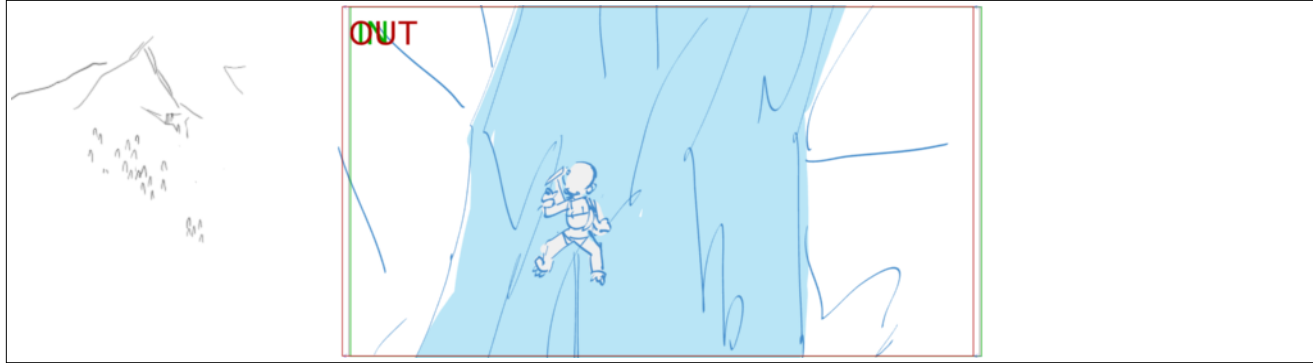





Scene	Duration	Panel	Duration
108	05:22	4	01:22

NO PANEL

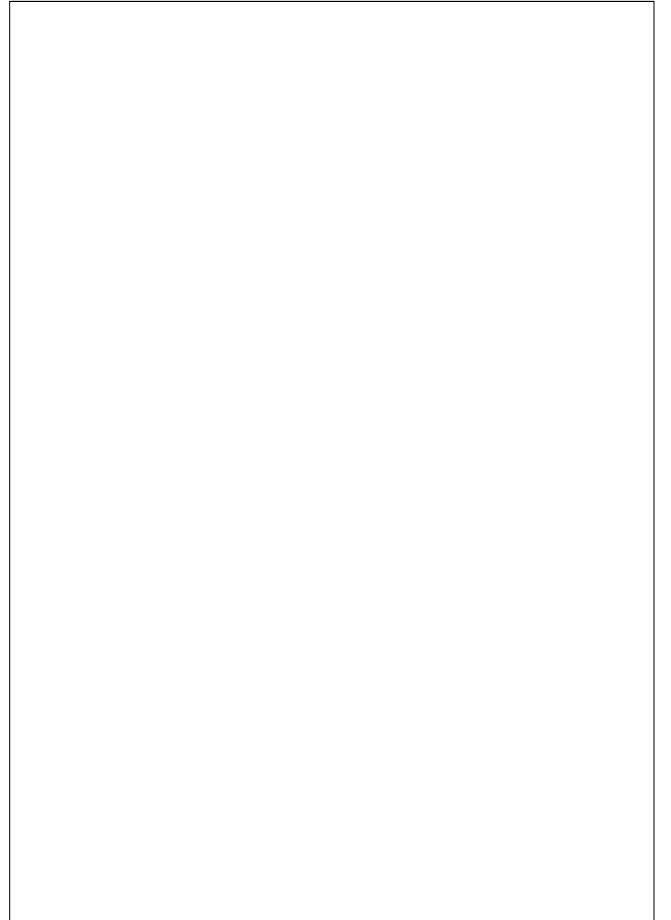
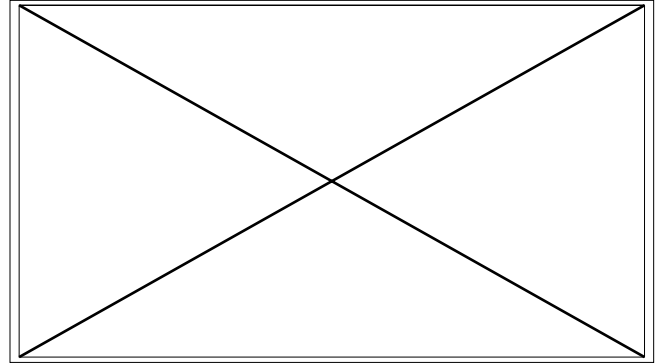
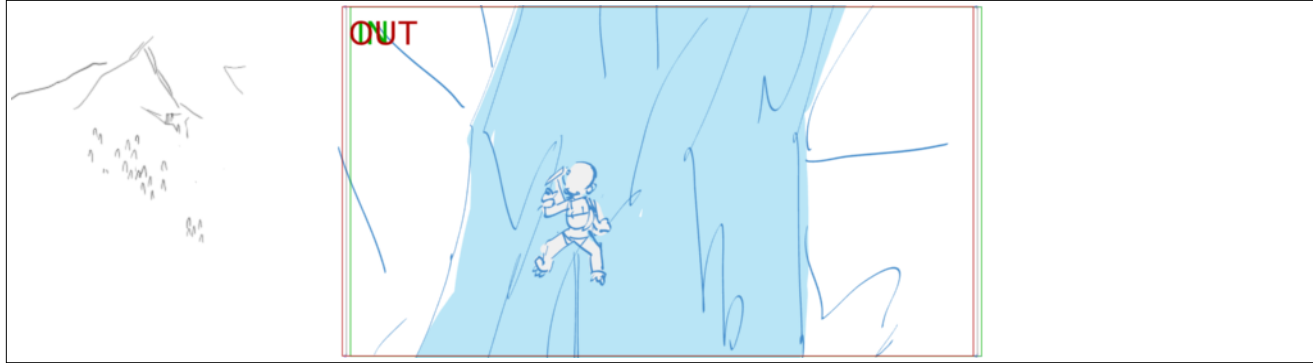



Scene	Duration	Panel	Duration
108	05:22	4	01:22

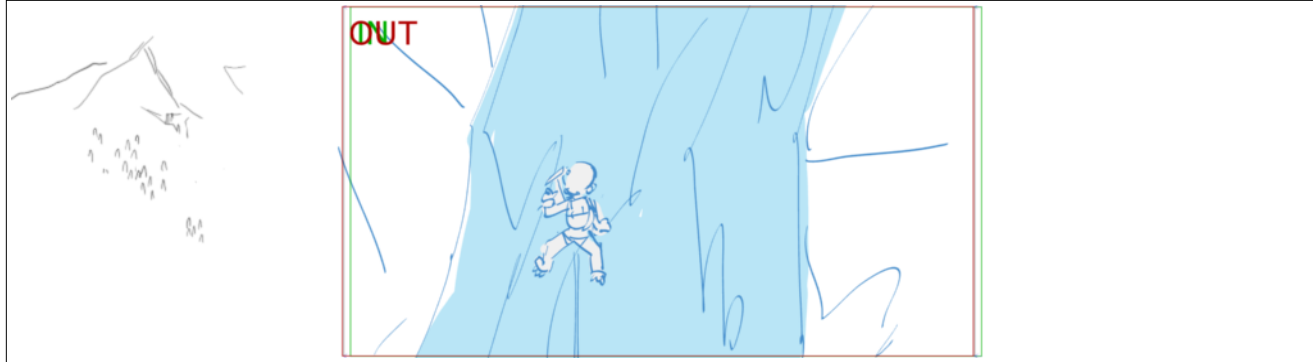

Scene	Duration	Panel	Duration
109	03:01	1	00:17

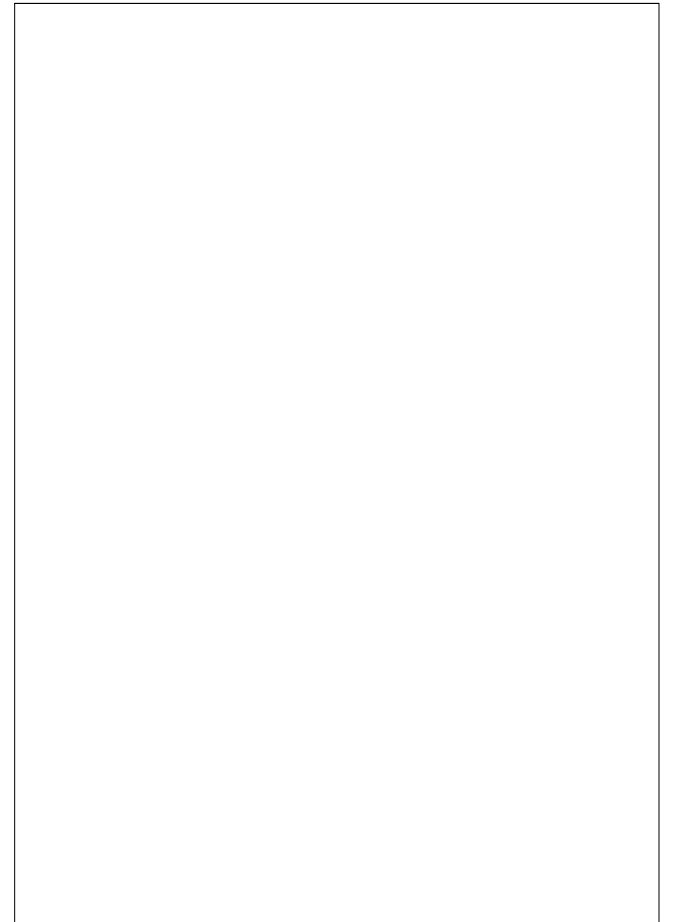
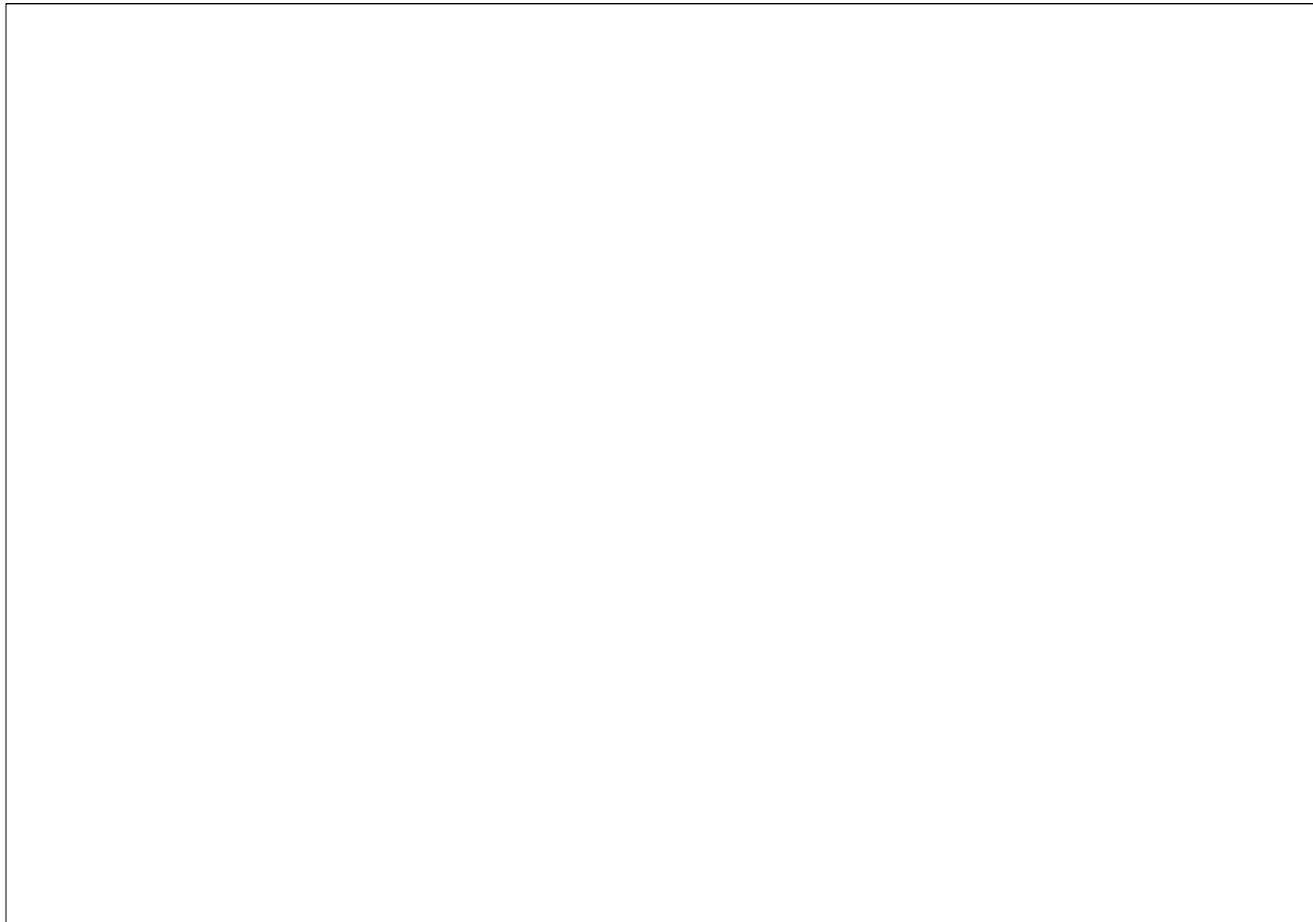
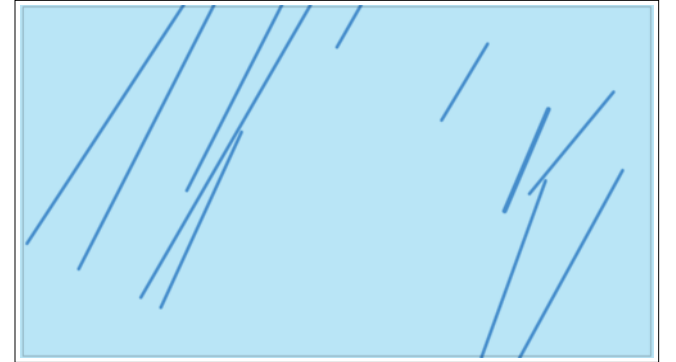

Scene	Duration	Panel	Duration
109	03:01	2	00:08



Scene	Duration	Panel	Duration
109	03:01	3	00:17



**Action Notes**  
 Main de SEB IN positionne un piton sur la glace

Scene	Duration	Panel	Duration
109	03:01	4	00:11

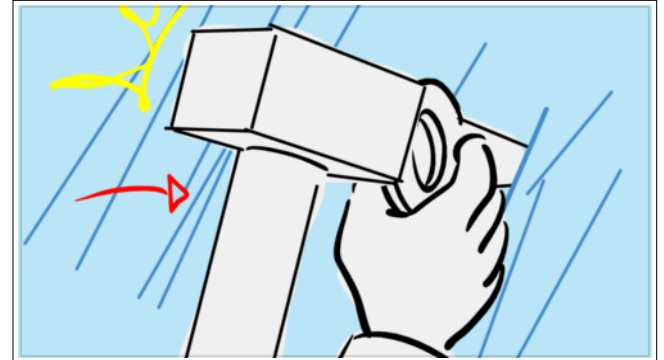

**Action Notes**  
 marteau IN enfonce le piton

Scene	Duration	Panel	Duration
109	03:01	5	00:09



Scene	Duration	Panel	Duration
109	03:01	6	00:10

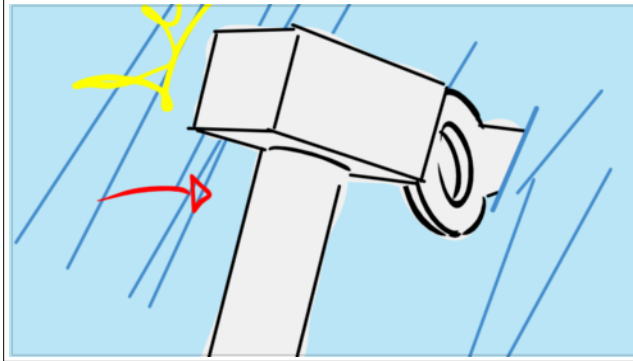

Scene	Duration	Panel	Duration
109	03:01	7	00:04

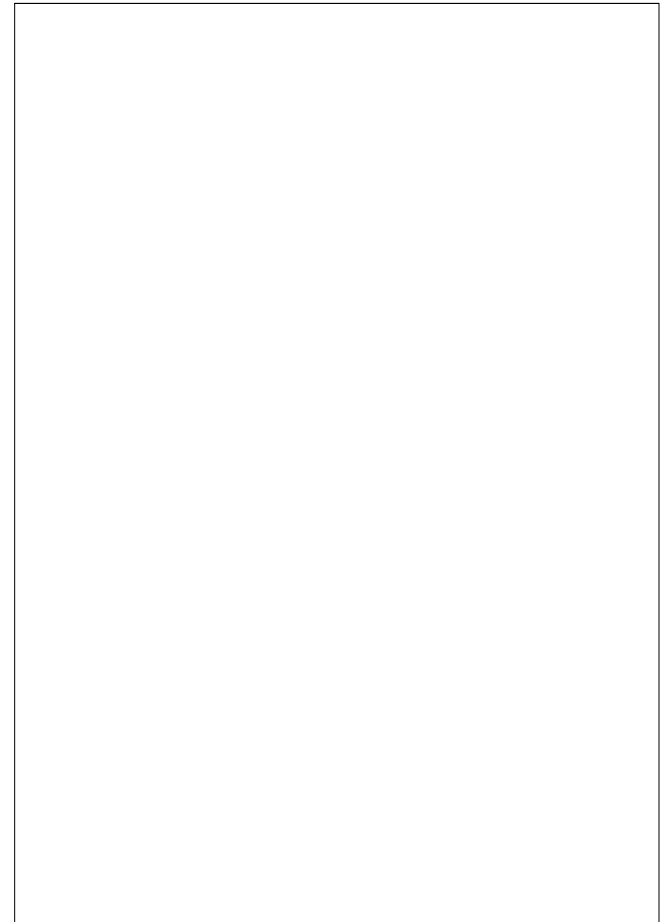
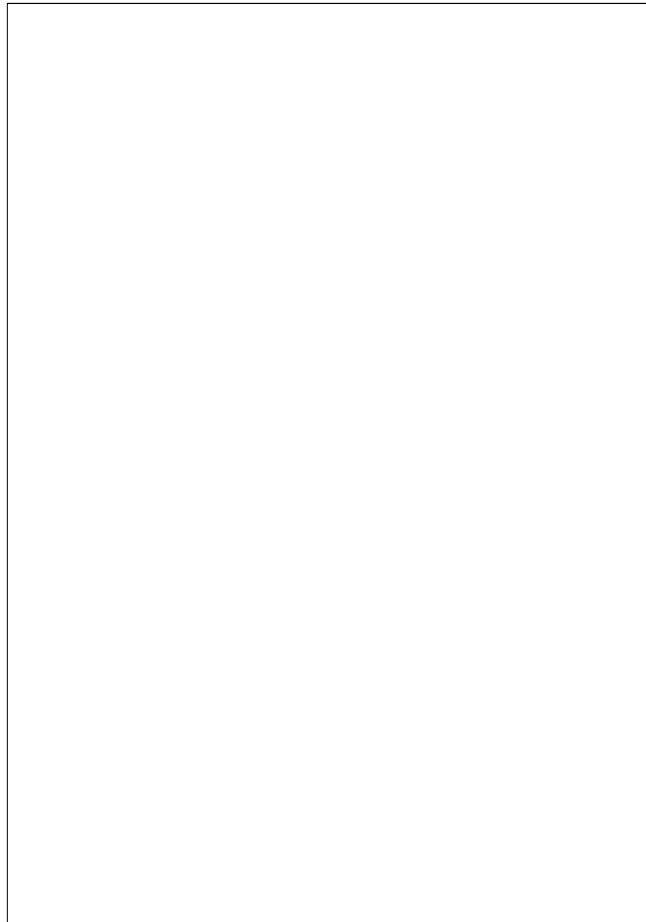
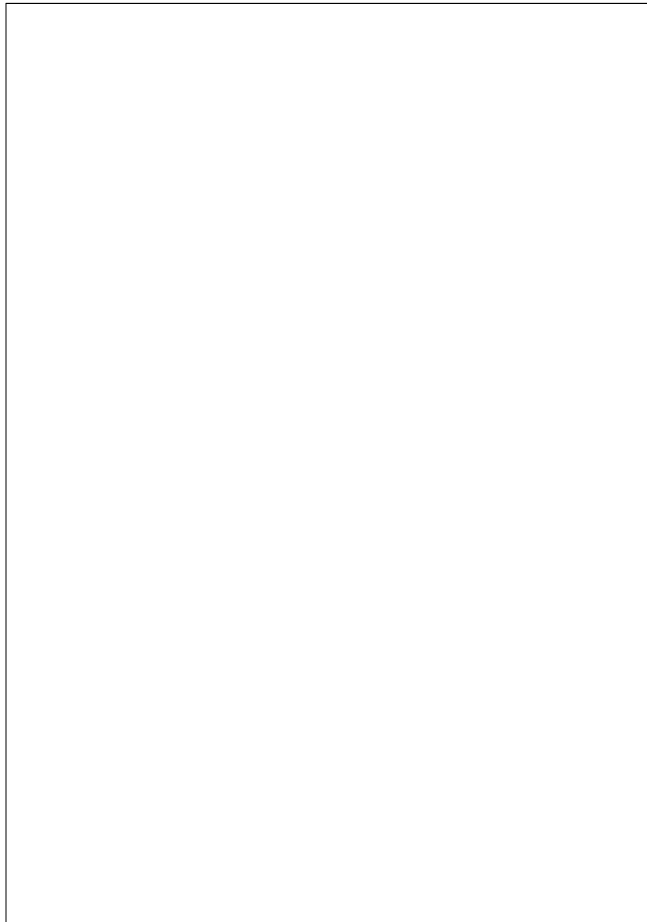
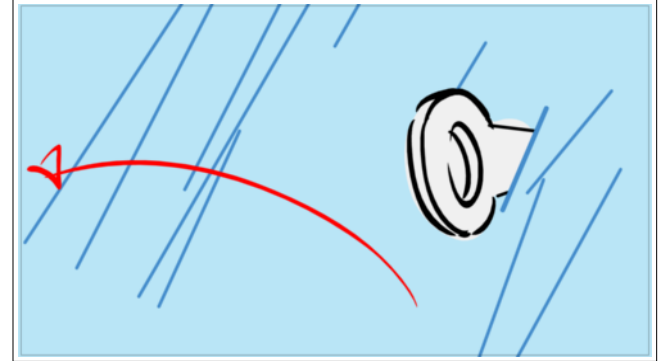

Scene	Duration	Panel	Duration
110	05:19	1	00:08



**Action Notes**

SEb tape sur le piton avec son marteau

Scene	Duration	Panel	Duration
110	05:19	2	00:11

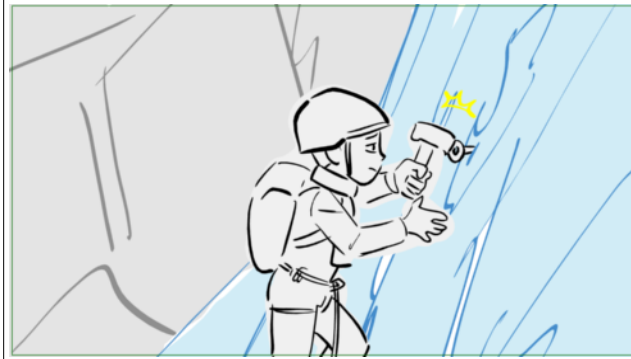

Scene	Duration	Panel	Duration
110	05:19	3	00:10



Scene	Duration	Panel	Duration
110	05:19	4	00:11



Scene	Duration	Panel	Duration
110	05:19	5	01:00

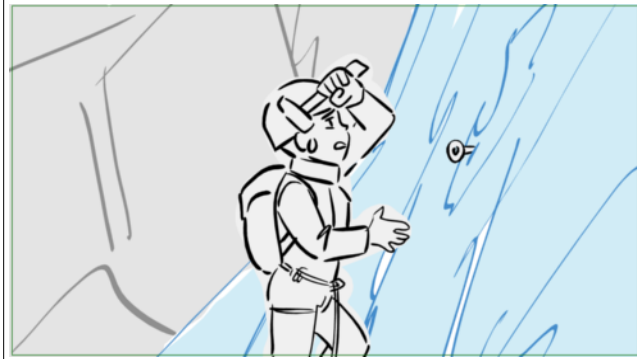

NO PANEL

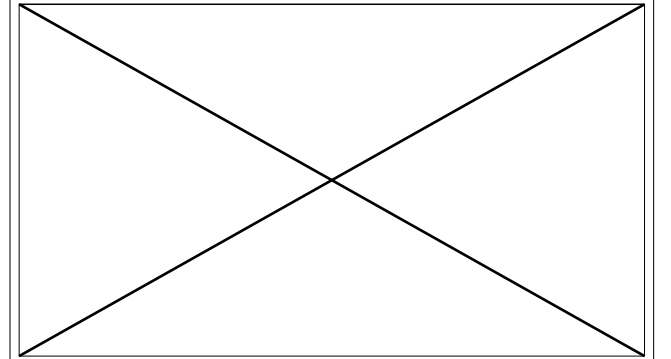

**Dialogue**

73. SEBASTIEN  
(haletant) Hh-hh...

**Action Notes**

s'arrête hors d'haleine et s'essuie le front

Scene	Duration	Panel	Duration
110	05:19	6	02:14

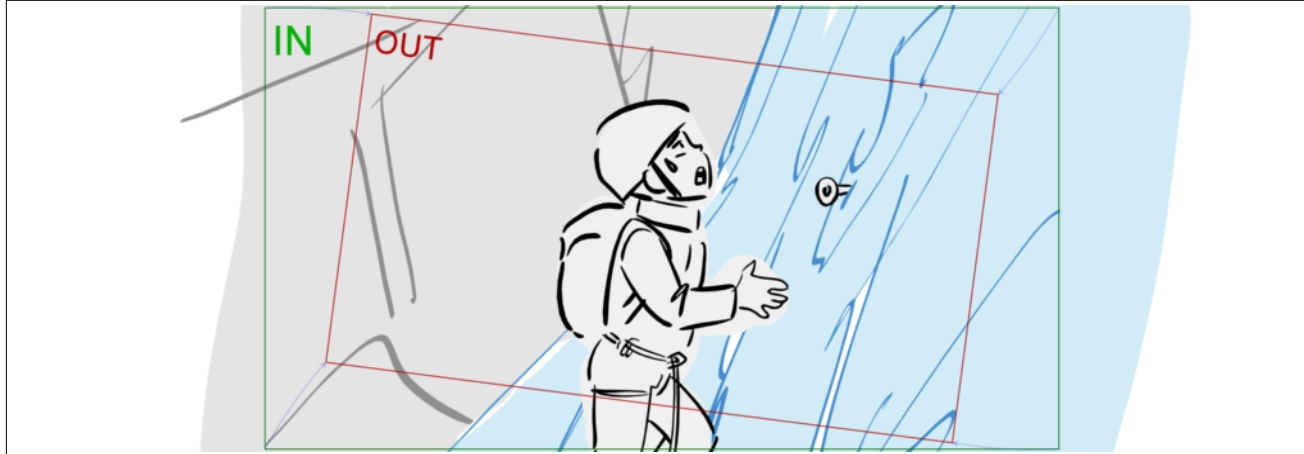
**Dialogue**

73. SEBASTIEN

Je l'imaginais plus près, hh... ce sommet !

**Action Notes**

TILT TRK IN

NO PANEL

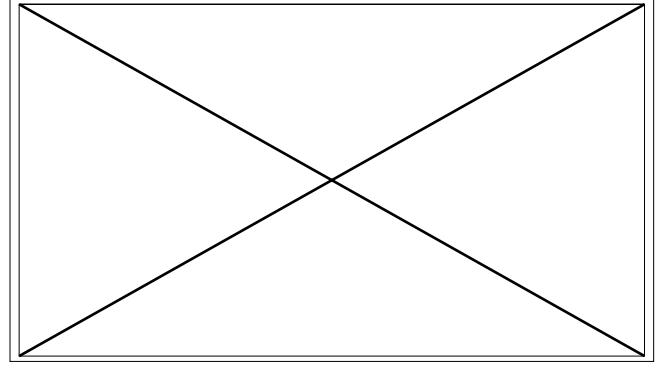



Scene	Duration	Panel	Duration
110	05:19	7	00:15

NO PANEL

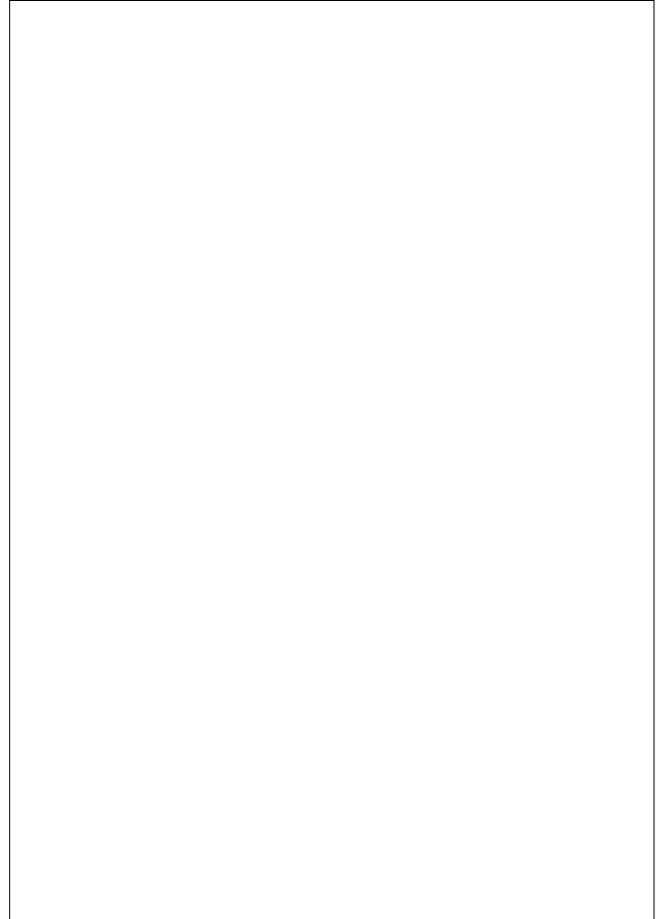
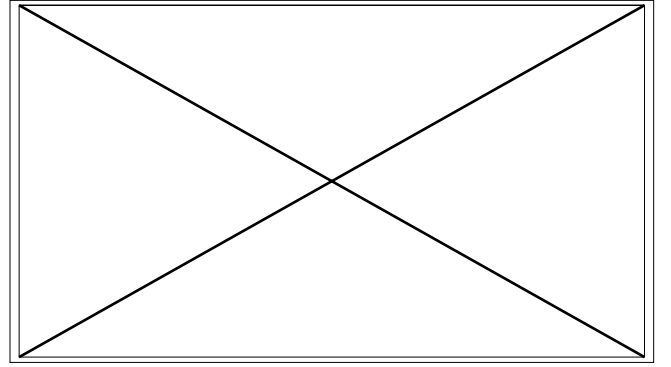
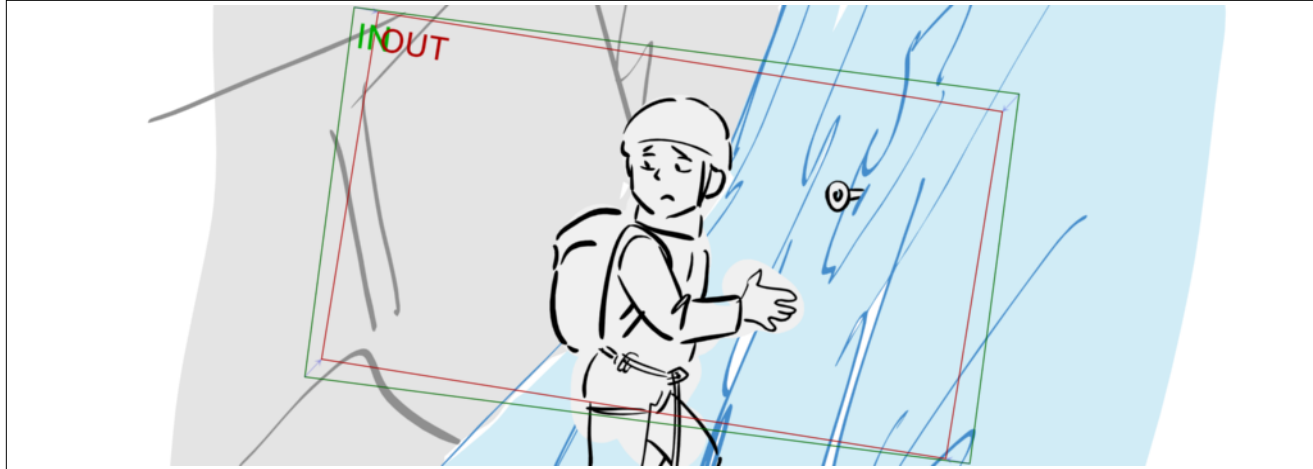





Scene	Duration	Panel	Duration
111	01:14	1	00:19

NO PANEL

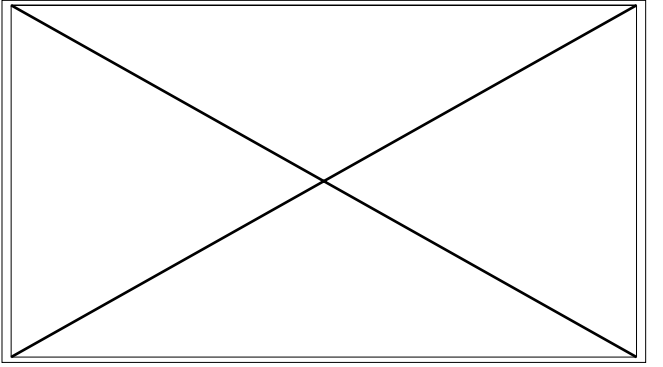
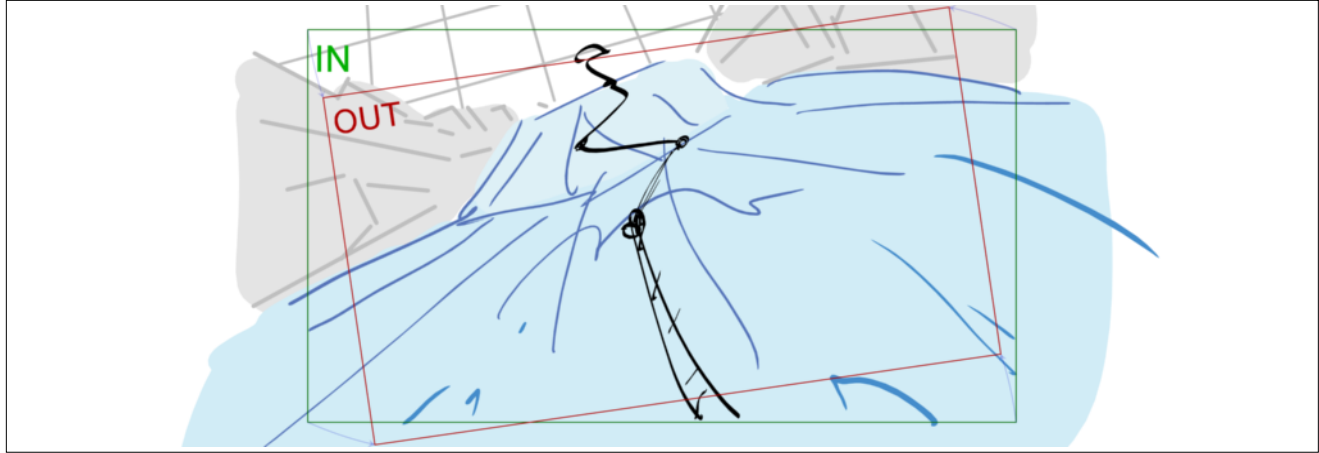

**Action Notes**

DOWN SHOT  
TILT TRK IN

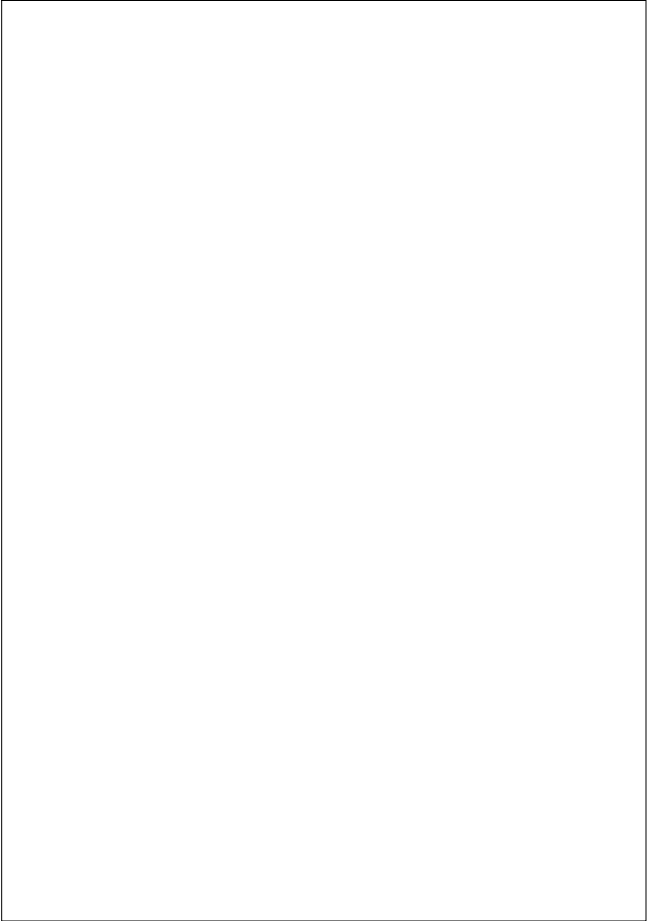



Scene	Duration	Panel	Duration
111	01:14	2	00:20

NO PANEL

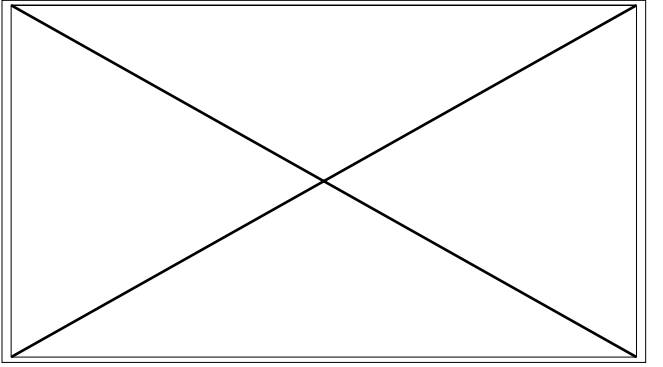
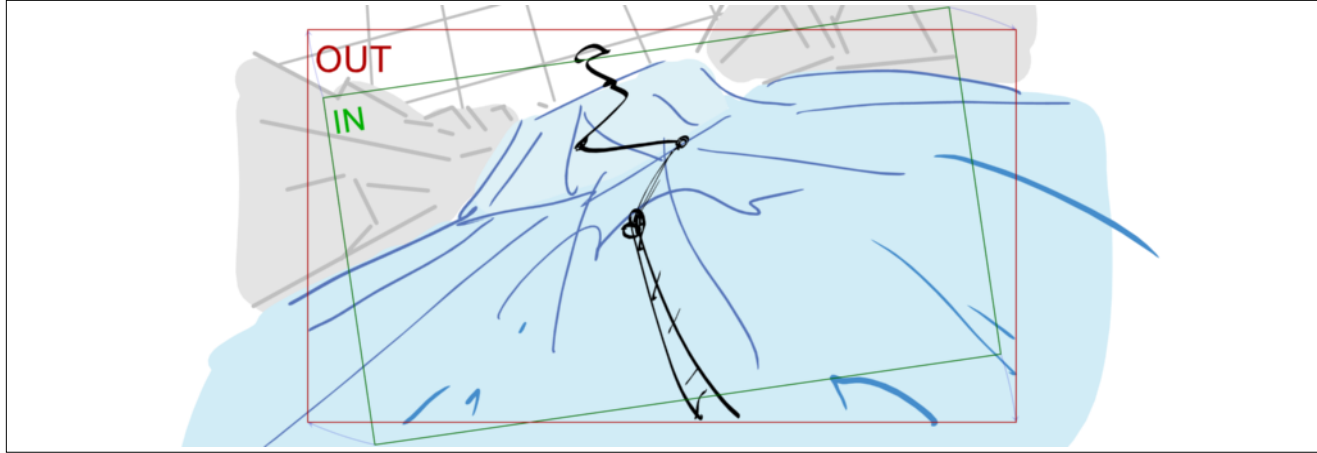

**Action Notes**

TILT TRK OUT

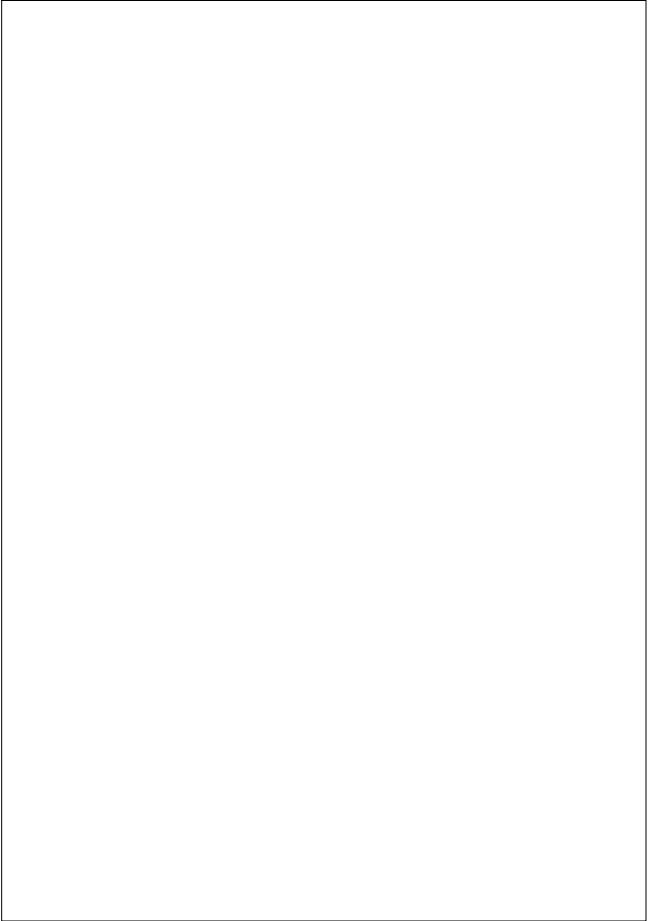



Scene	Duration	Panel	Duration
112	02:16	1	00:08

NO PANEL

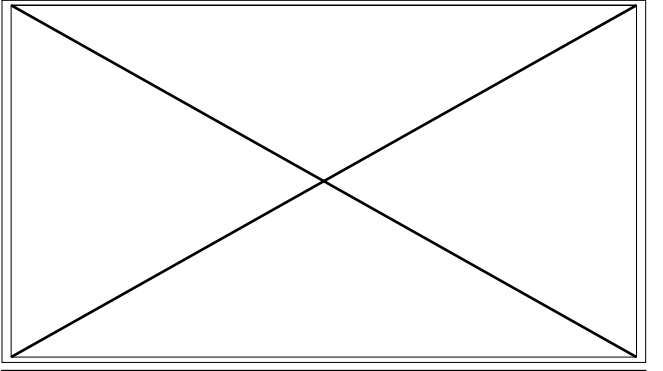

**Action Notes**  
TILT TRK IN

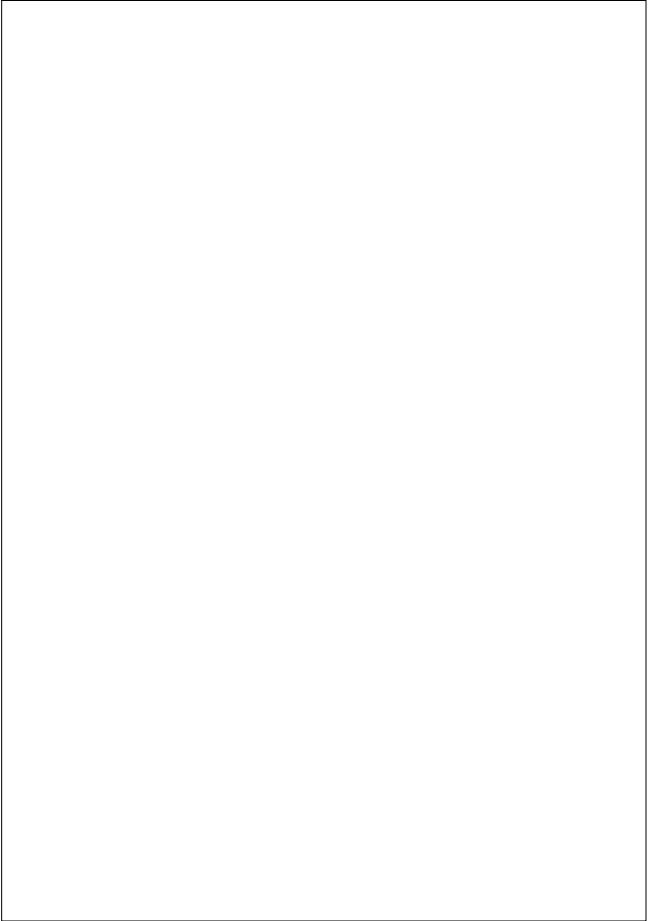



Scene	Duration	Panel	Duration
112	02:16	2	01:16

NO PANEL

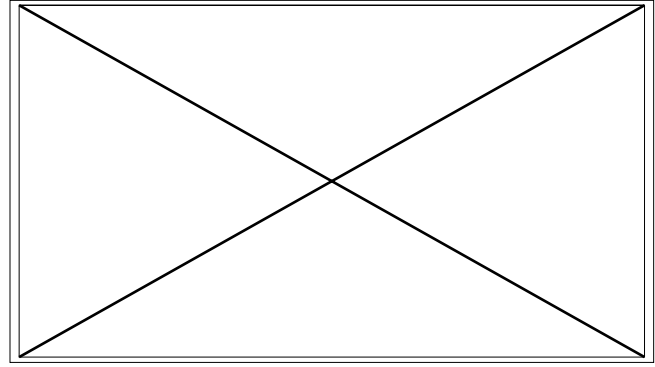
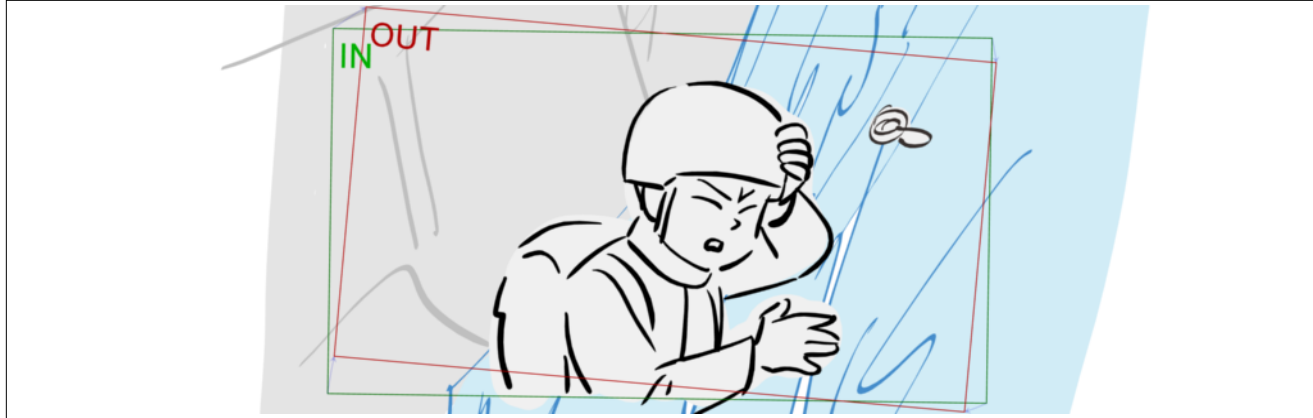

**Dialogue**  
74. SEBASTIEN  
Oh, ma tête...

**Action Notes**  
SEB se tient la tête

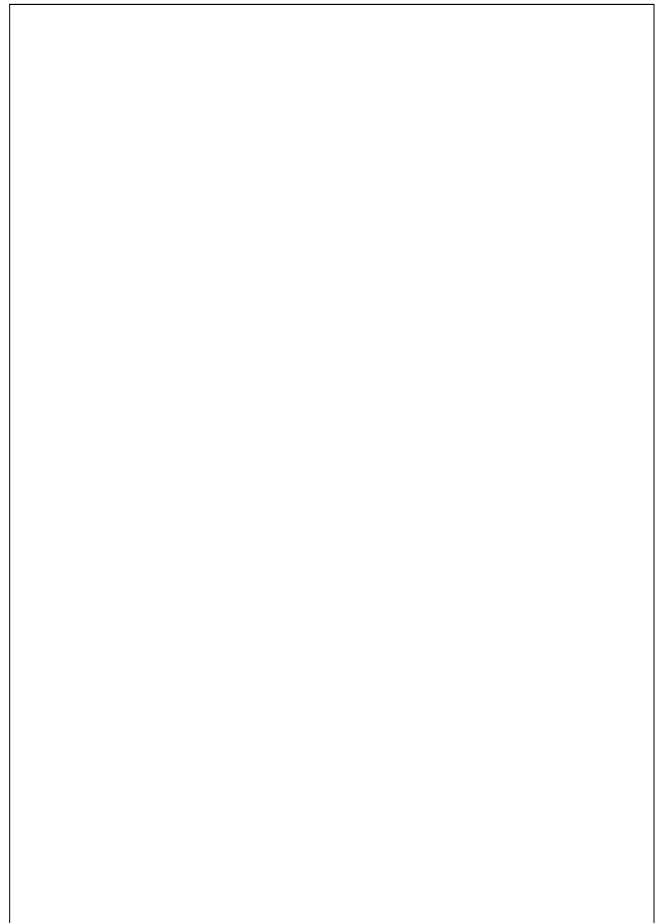

Scene	Duration	Panel	Duration
112	02:16	3	00:17

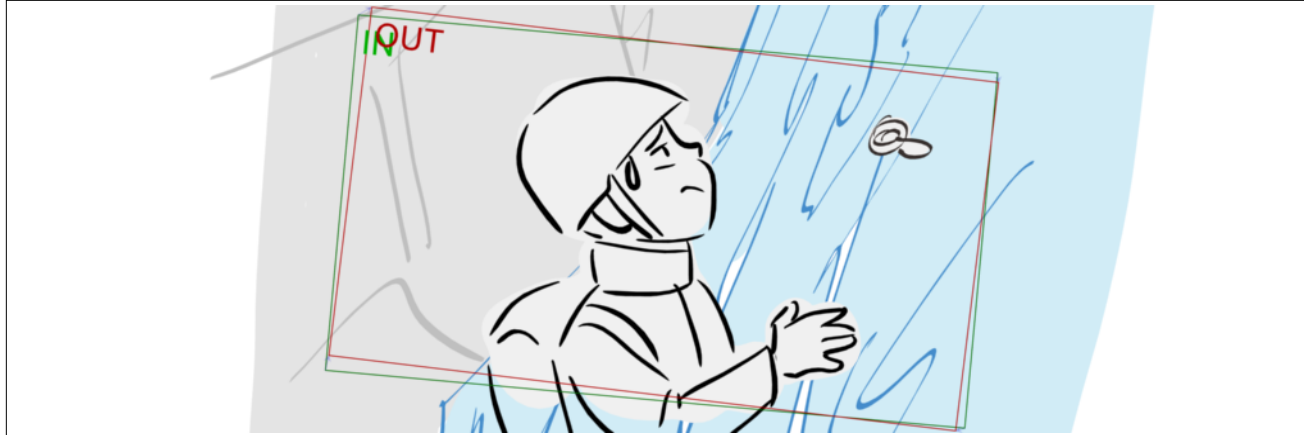
**Dialogue**

75. BELLE  
(inquiète) Wouf !

**Action Notes**

et regarde en haut

NO PANEL

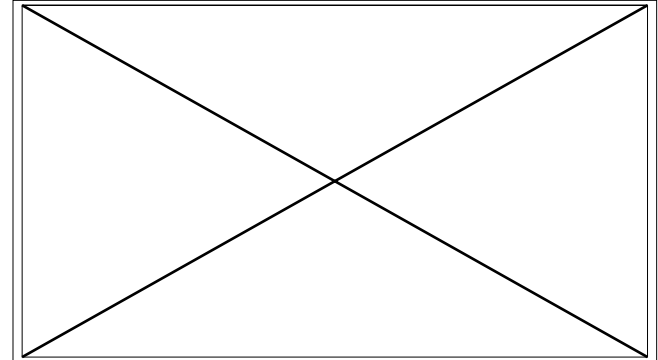



Scene	Duration	Panel	Duration
113	02:22	1	00:09

NO PANEL

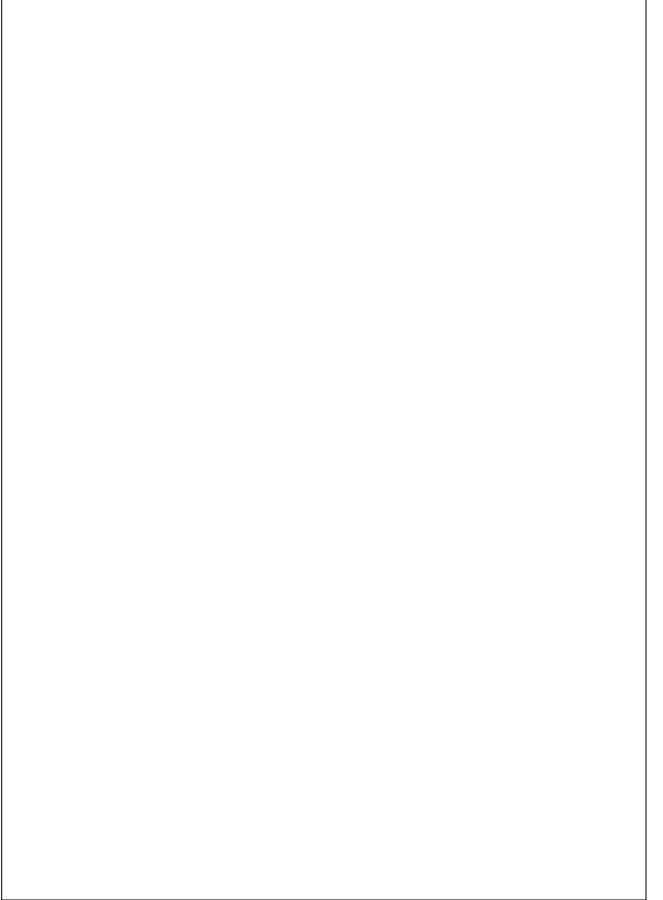
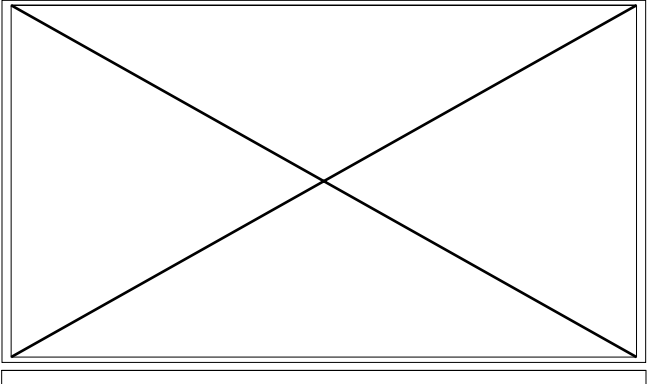
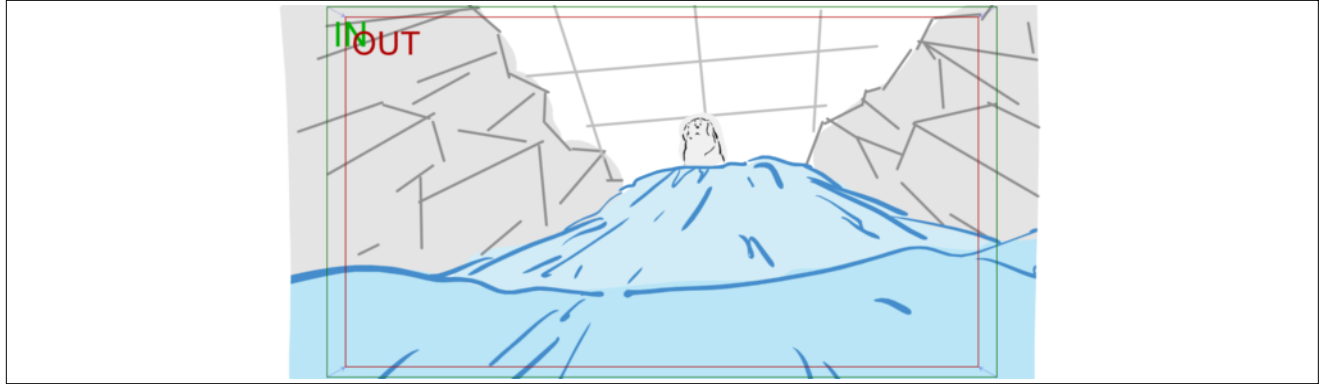

Scene	Duration	Panel	Duration
113	02:22	2	00:20

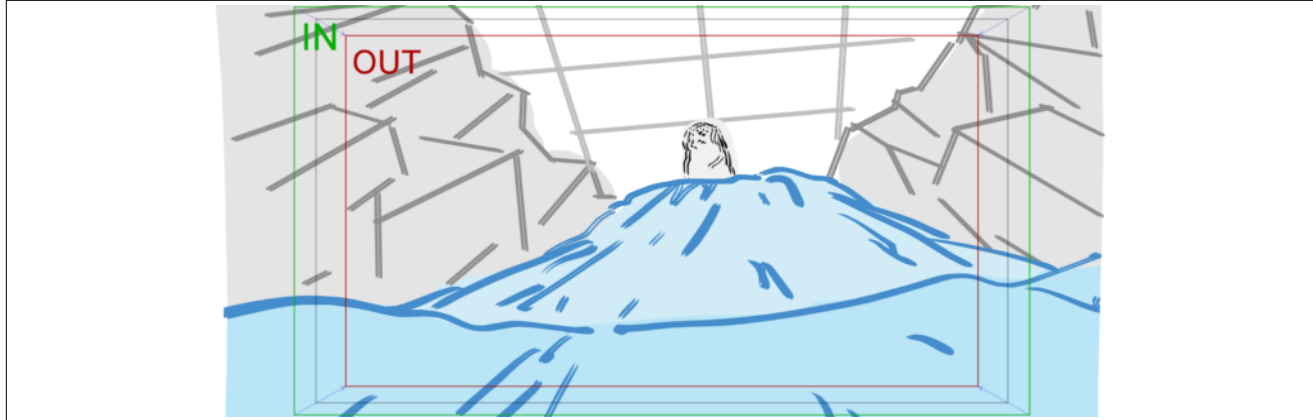

**Action Notes**

TRK IN sur Belle au dessus

Scene	Duration	Panel	Duration
113	02:22	3	00:18

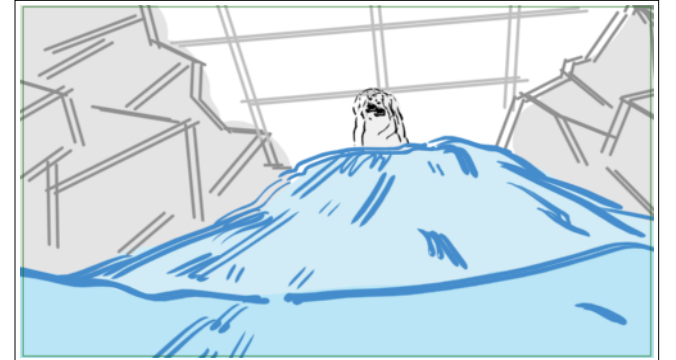

**Action Notes**

image se dédouble

BLUR IN

Scene	Duration	Panel	Duration
113	02:22	4	01:00

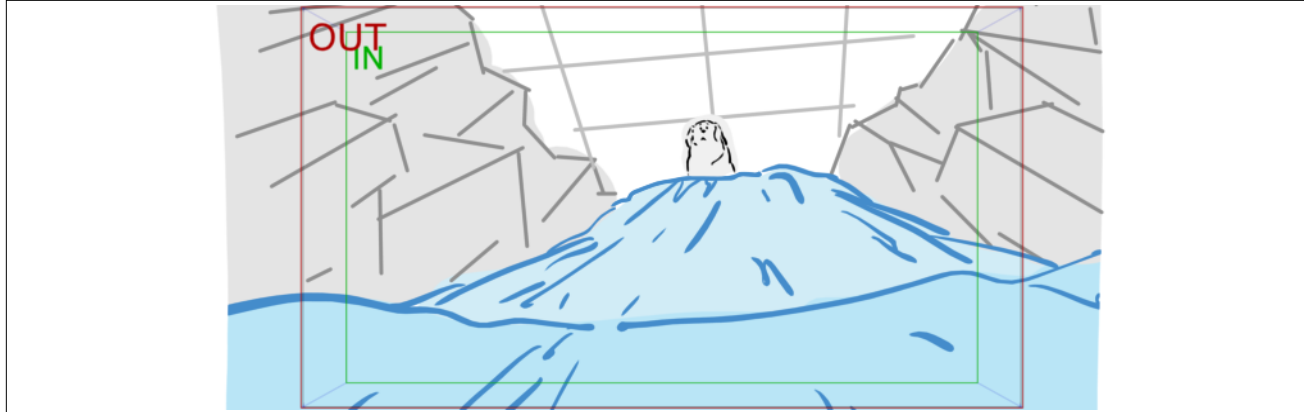

NO PANEL

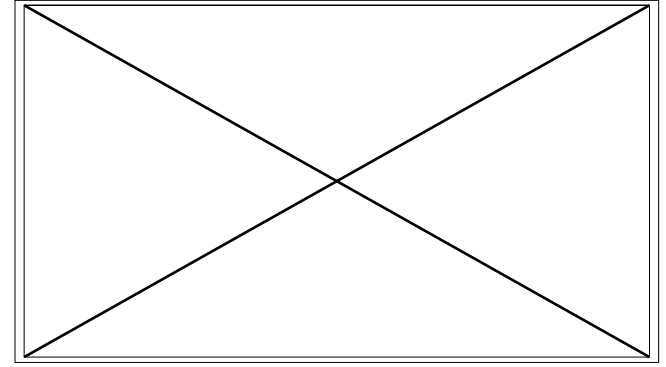
**Dialogue**

75. BELLE  
(inquiète) Wouf !

**Action Notes**

TRK OUT  
+BLUR OUT

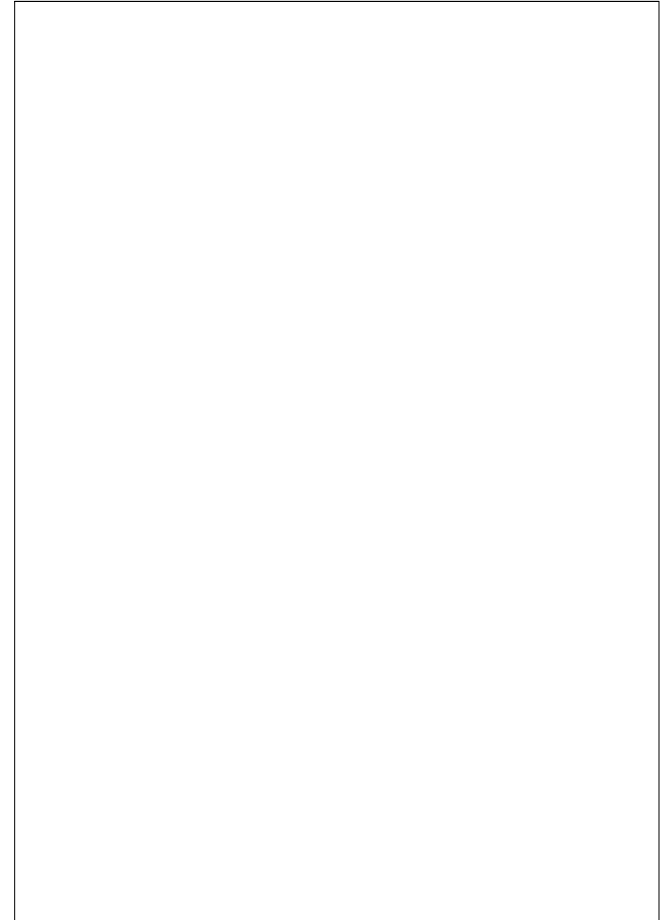





Scene	Duration	Panel	Duration
114	03:08	1	00:12

NO PANEL

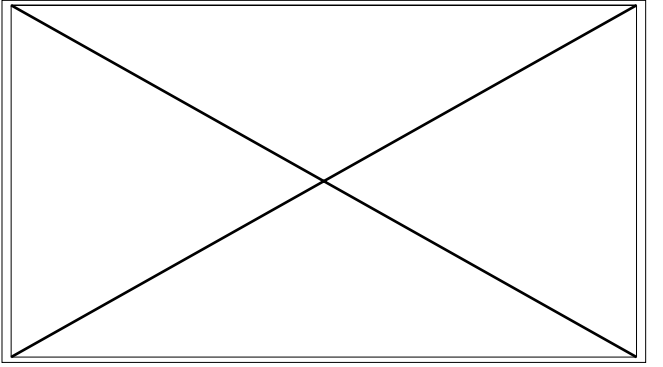
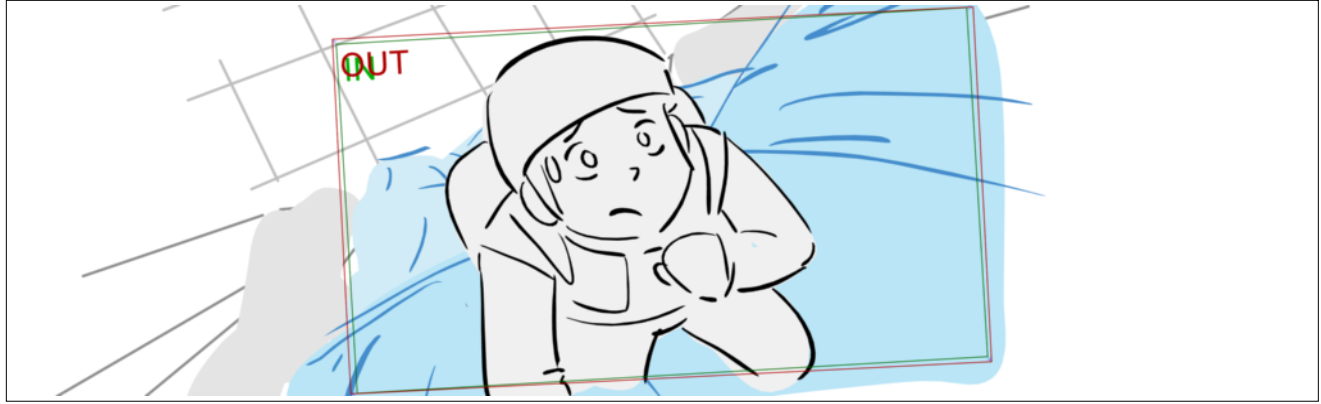

**Action Notes**

SLOW TILT TRK OUT

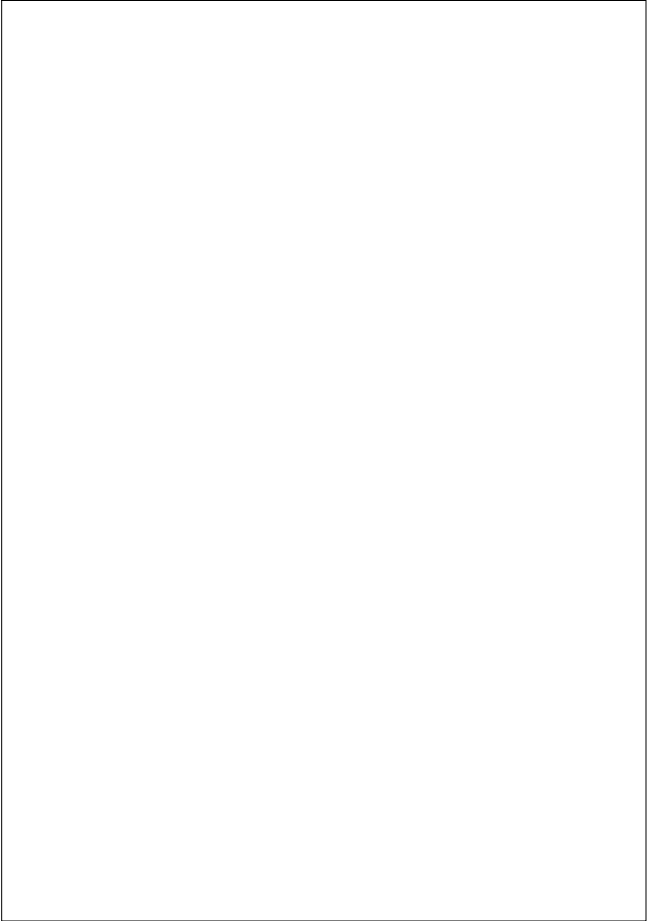



Scene	Duration	Panel	Duration
114	03:08	2	00:08

NO PANEL

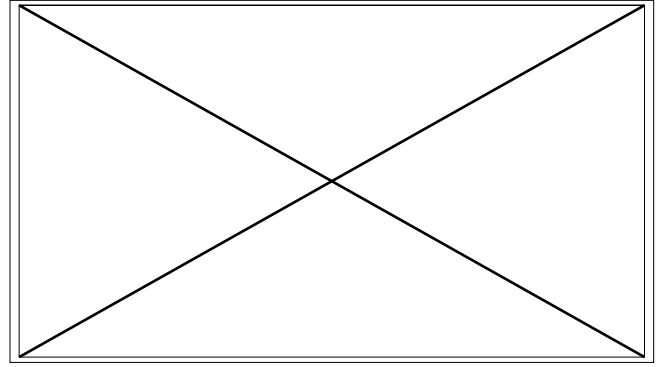
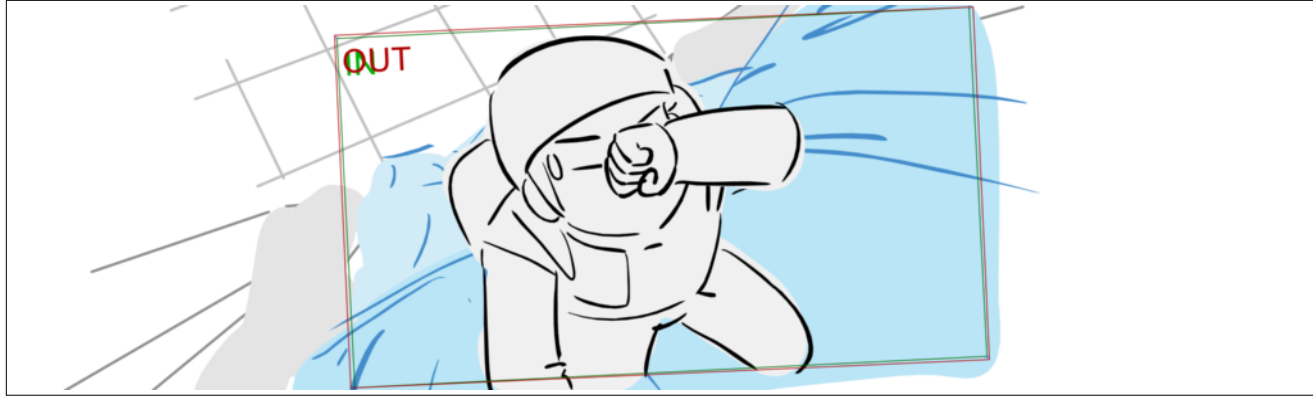

**Action Notes**

SEB se frotte les yeux

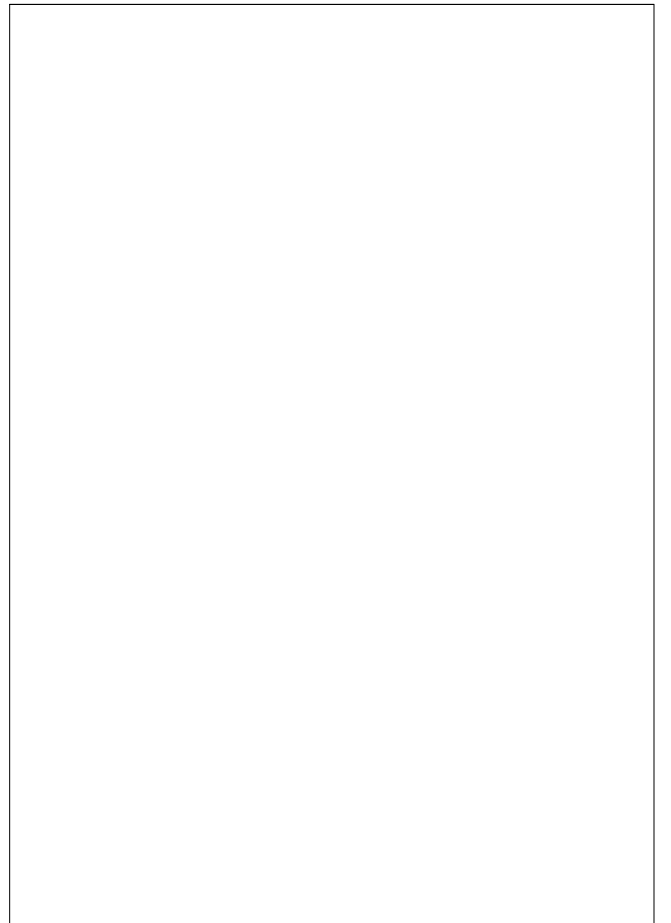



Scene	Duration	Panel	Duration
114	03:08	3	00:09

NO PANEL

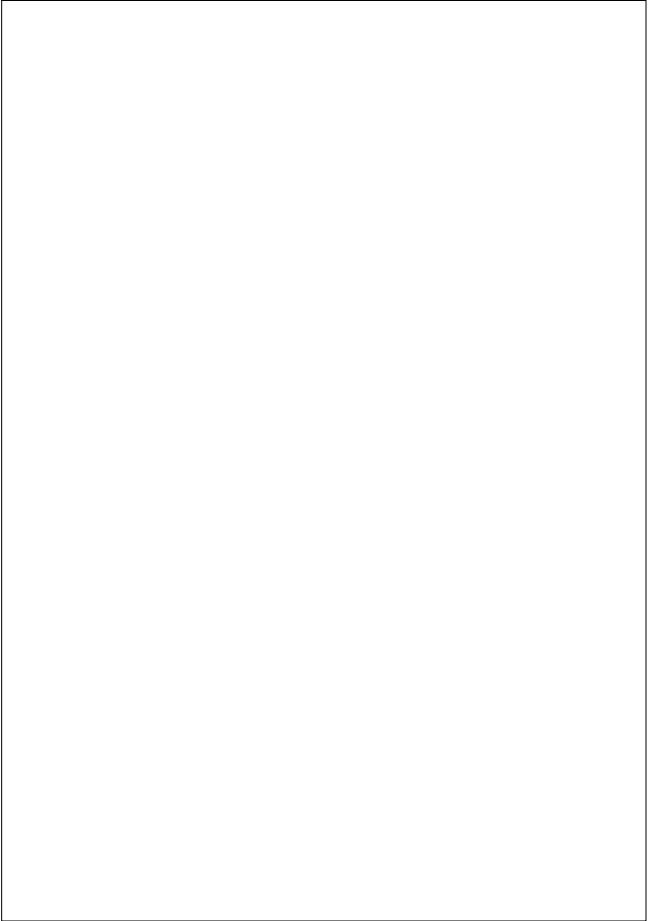
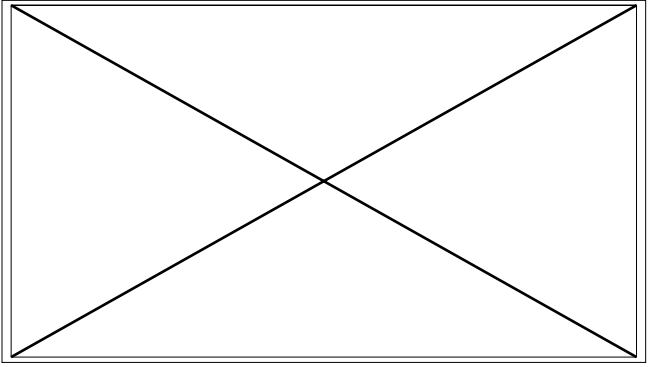
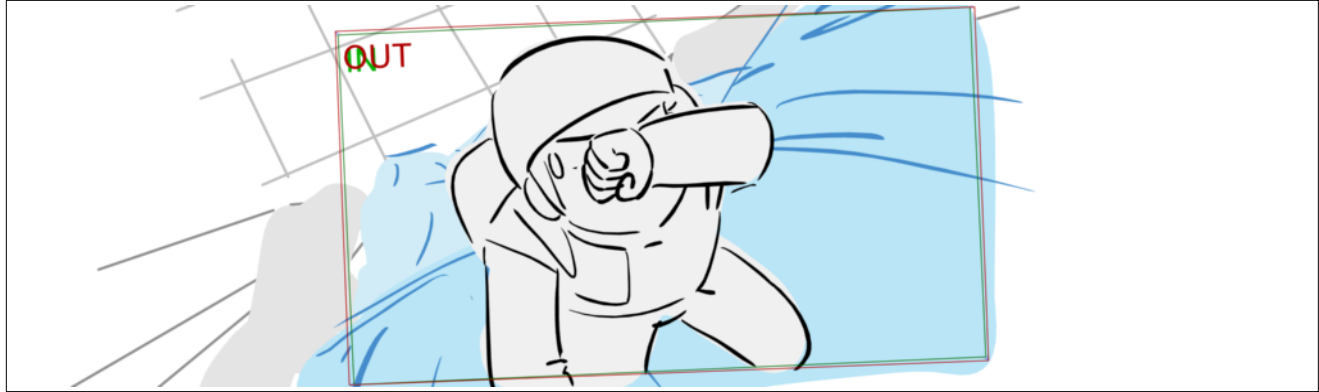



Scene	Duration	Panel	Duration
114	03:08	4	00:08

NO PANEL

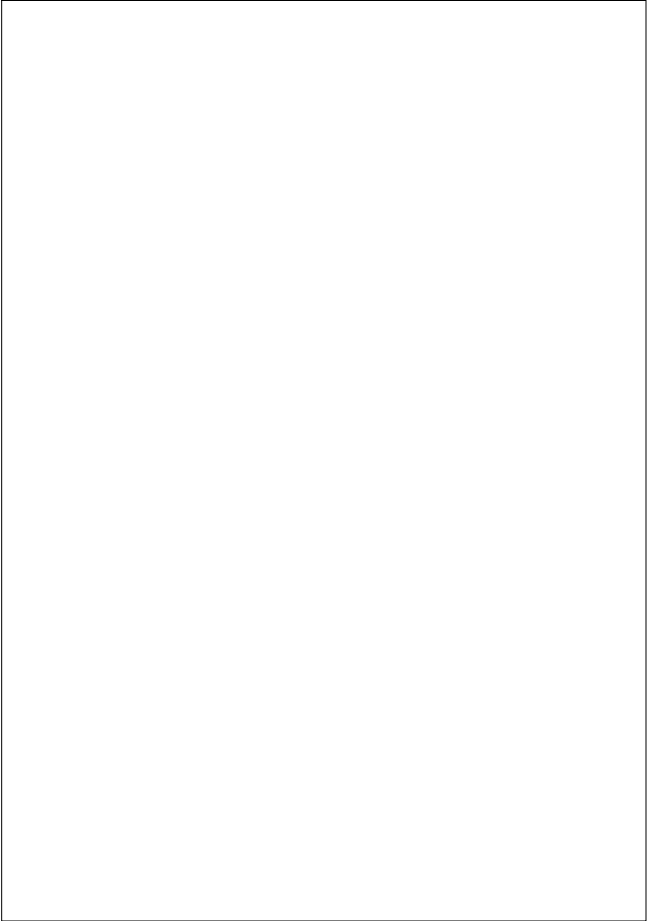
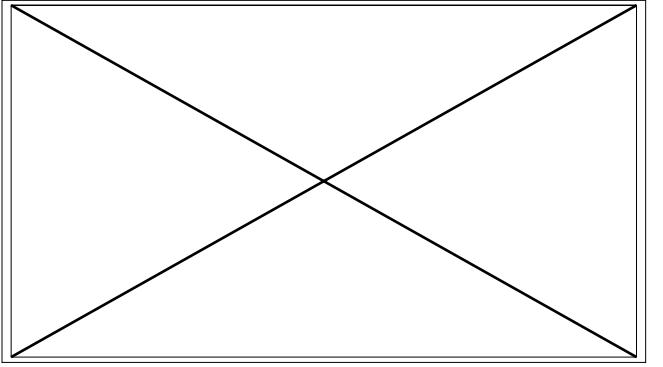
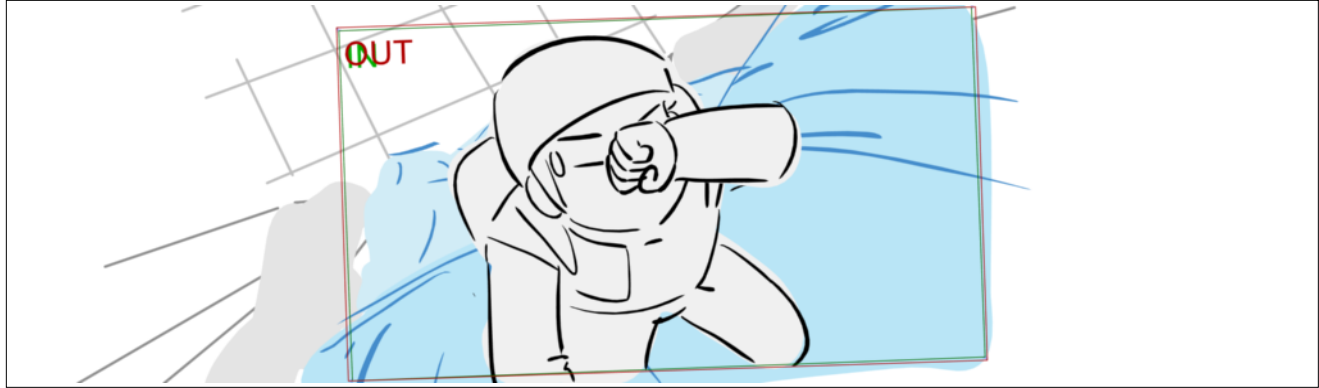

Scene	Duration	Panel	Duration
114	03:08	5	01:21

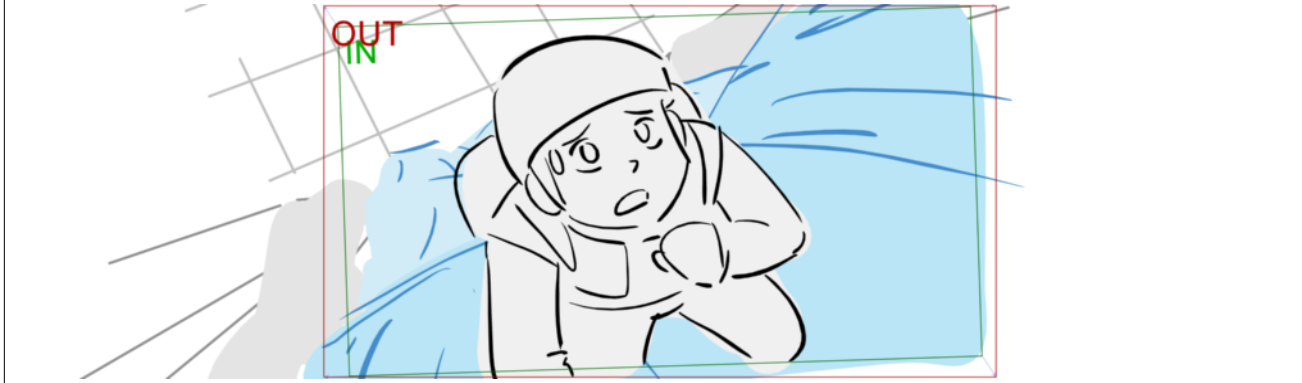
**Dialogue**

76. SÉBASTIEN (tente de la rassurer)  
Nan, nan, t'inquiète, ça va aller.

NO PANEL

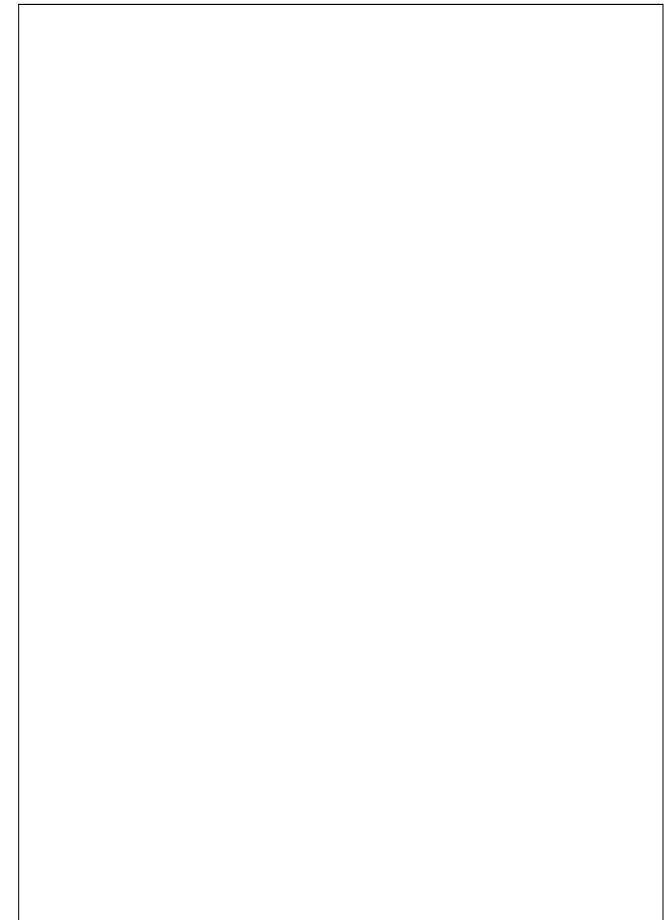
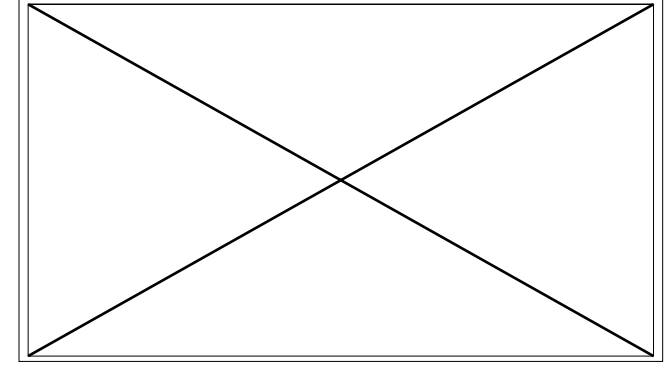

Scene	Duration	Panel	Duration
115	03:02	1	03:02

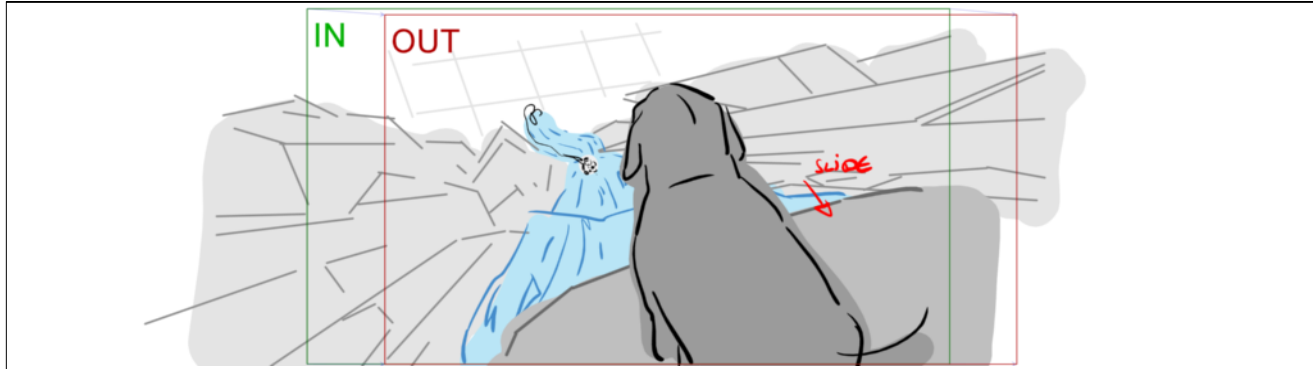

**Dialogue**

76. SÉBASTIEN (tente de la rassurer)  
Laisse-moi juste une minute pour reprendre mon souffle...

78. SÉBASTIEN  
On a dû monter trop vite...

**Action Notes**

SLOW PAN

Scene	Duration	Panel	Duration
116	02:02	1	00:06

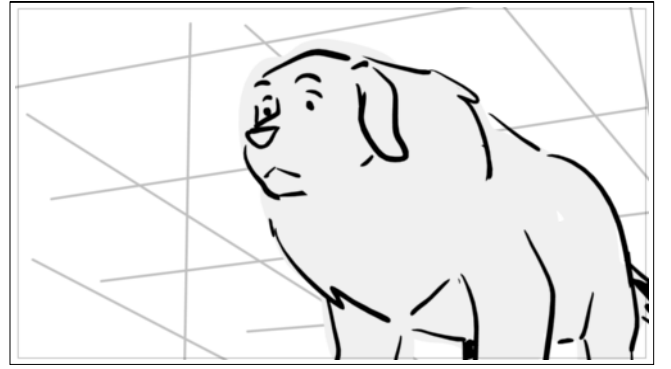

Scene	Duration	Panel	Duration
116	02:02	2	00:09

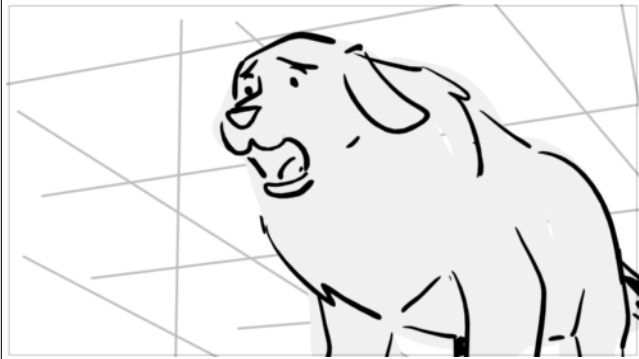
**Dialogue**

77. BELLE (sérieuse, t'es sûr que ça va ?)  
Wouf ?

Scene	Duration	Panel	Duration
116	02:02	3	00:15

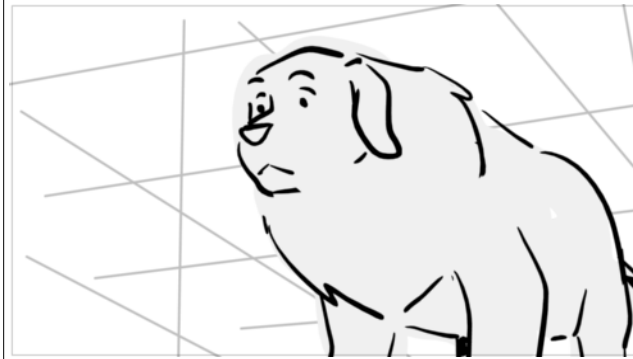
**Dialogue**

78. SÉBASTIEN  
(conscient) J'ai des petits vertiges,

Scene	Duration	Panel	Duration
116	02:02	4	00:22

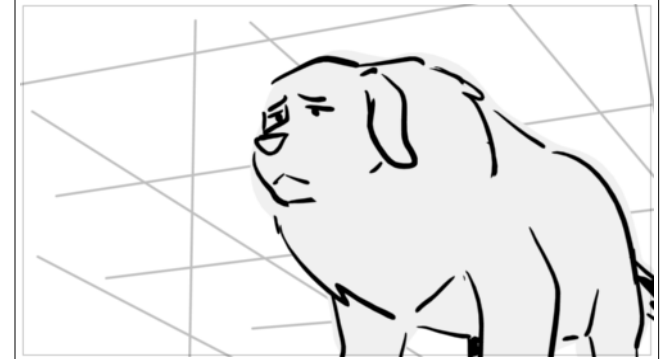
**Dialogue**

88. BELLE  
(inquiète) < Couine ! >

Scene	Duration	Panel	Duration
117	05:11	1	05:11

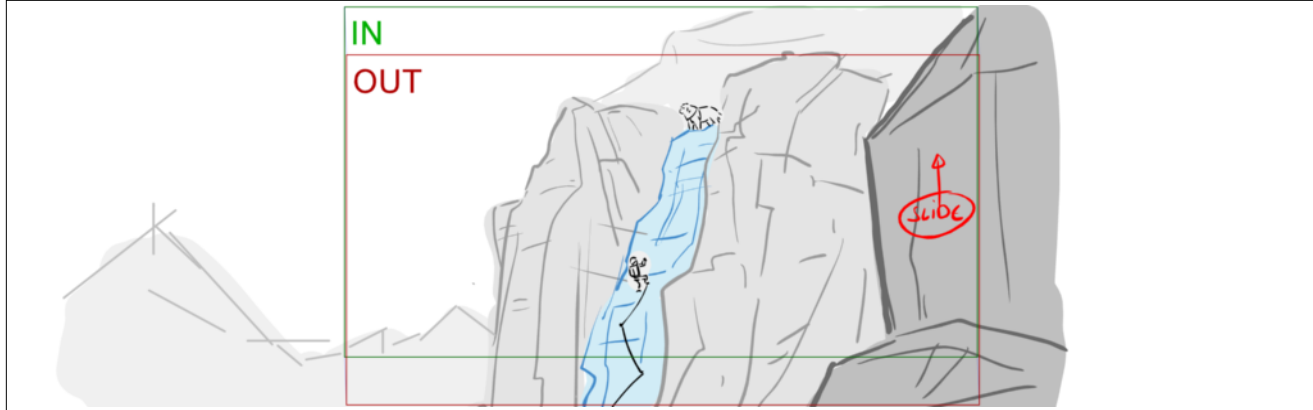

**Dialogue**

78. SÉBASTIEN  
ça doit être les effets de l'altitude. Mais ça va aller, ça va aller...

Scene	Duration	Panel	Duration
055_A	03:09	1	00:14

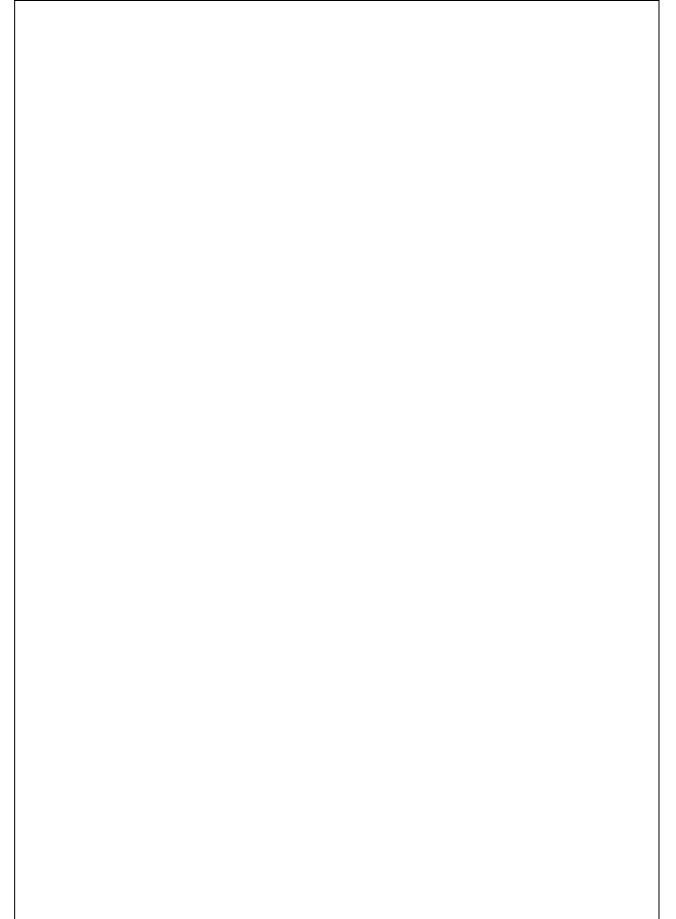
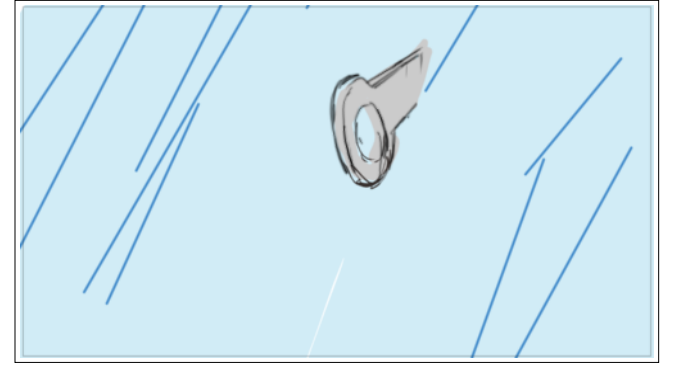



Scene	Duration	Panel	Duration
055_A	03:09	2	00:14

Scene	Duration	Panel	Duration
055_A	03:09	3	00:14

Scene	Duration	Panel	Duration
055_A	03:09	4	00:14

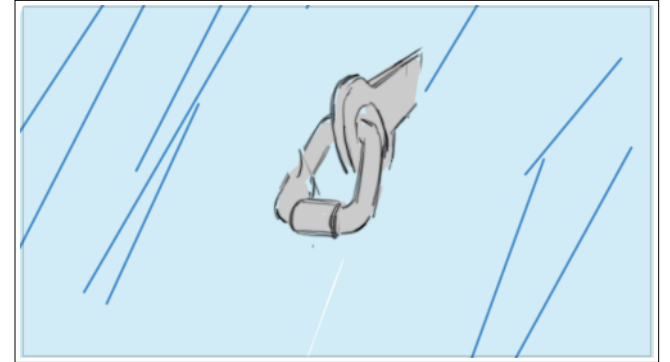
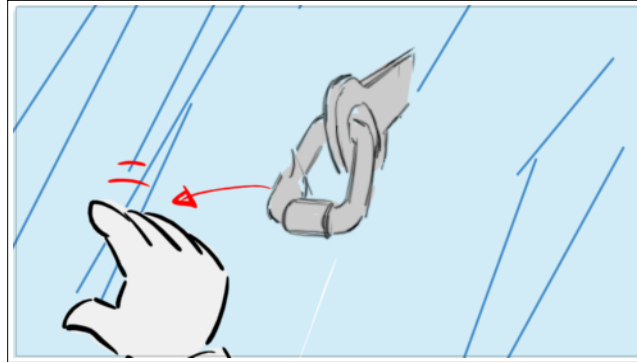
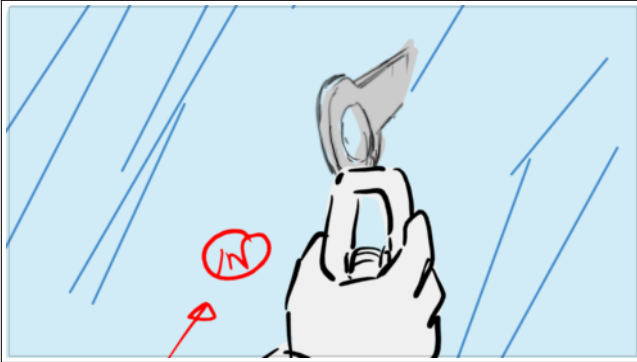

**Action Notes**

SEP accroche un mousqueton

Scene	Duration	Panel	Duration
055_A	03:09	5	00:14

Scene	Duration	Panel	Duration
055_A	03:09	6	00:14

Scene	Duration	Panel	Duration
119	02:00	1	01:00

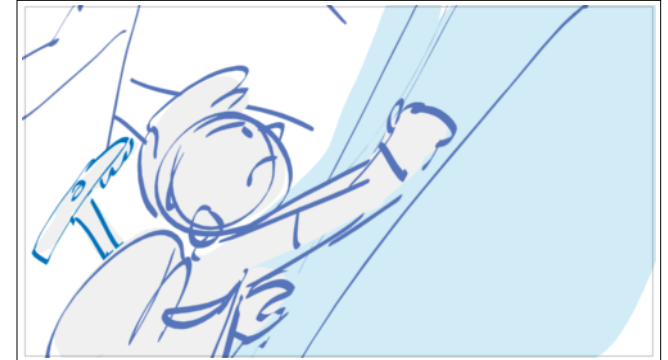
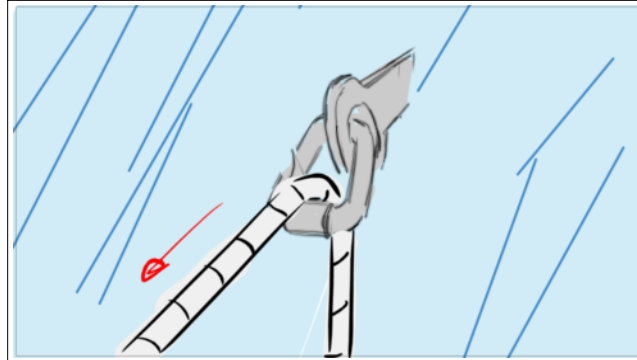
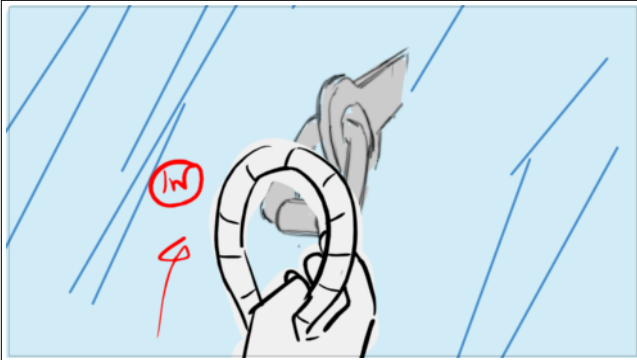

**Action Notes**

et accroche sa corde

**Action Notes**

Seb reprend son ascension

Scene	Duration	Panel	Duration
119	02:00	2	01:00

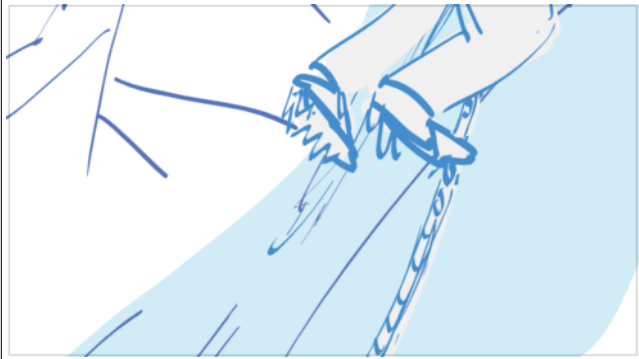

Scene	Duration	Panel	Duration
116_A	01:10	1	00:10

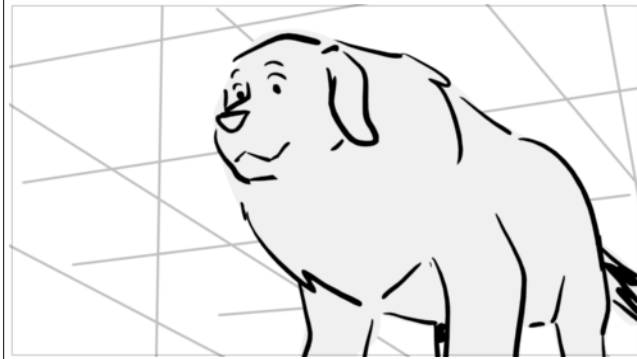

Scene	Duration	Panel	Duration
116_A	01:10	2	00:15

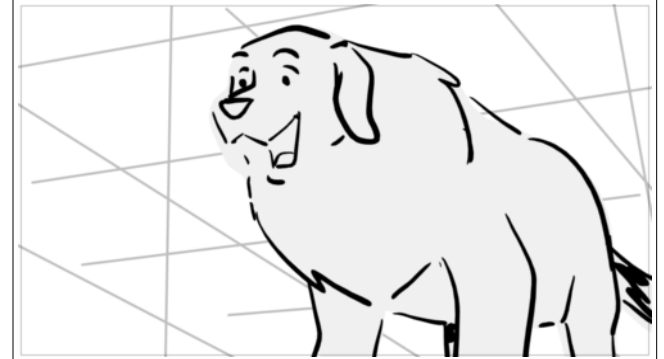

**Dialogue**

PU BELLE  
WOUF!

**Action Notes**

Belle l'encourage

Scene	Duration	Panel	Duration
116_A	01:10	3	00:10

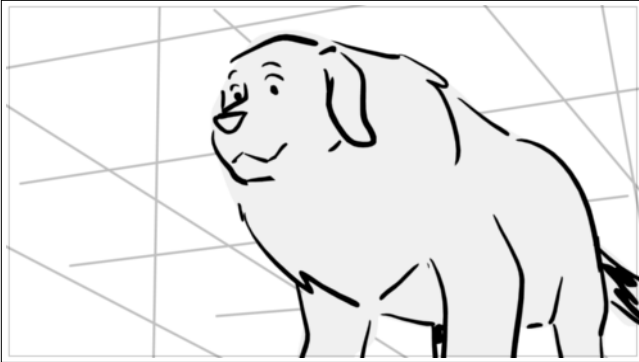

Scene	Duration	Panel	Duration
108_A	02:21	1	00:19

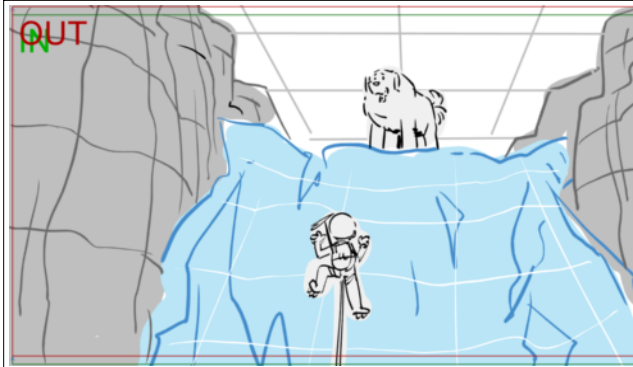

**Action Notes**  
 PAN UP FOLLOW  
 SEB grimpe vers Belle

Scene	Duration	Panel	Duration
108_A	02:21	2	00:17

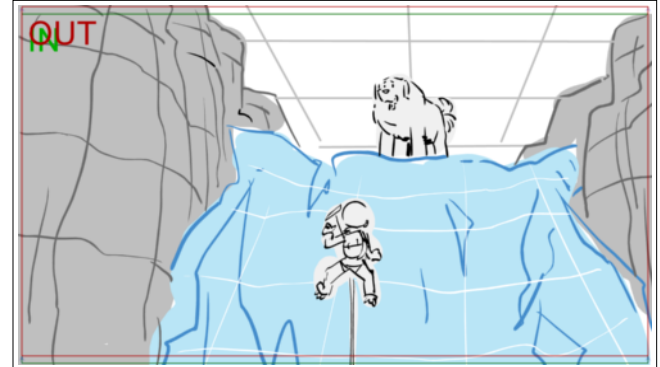

Scene	Duration	Panel	Duration
108_A	02:21	3	00:15

Scene	Duration	Panel	Duration
108_A	02:21	4	00:20

Scene	Duration	Panel	Duration
108_B	04:12	1	00:13

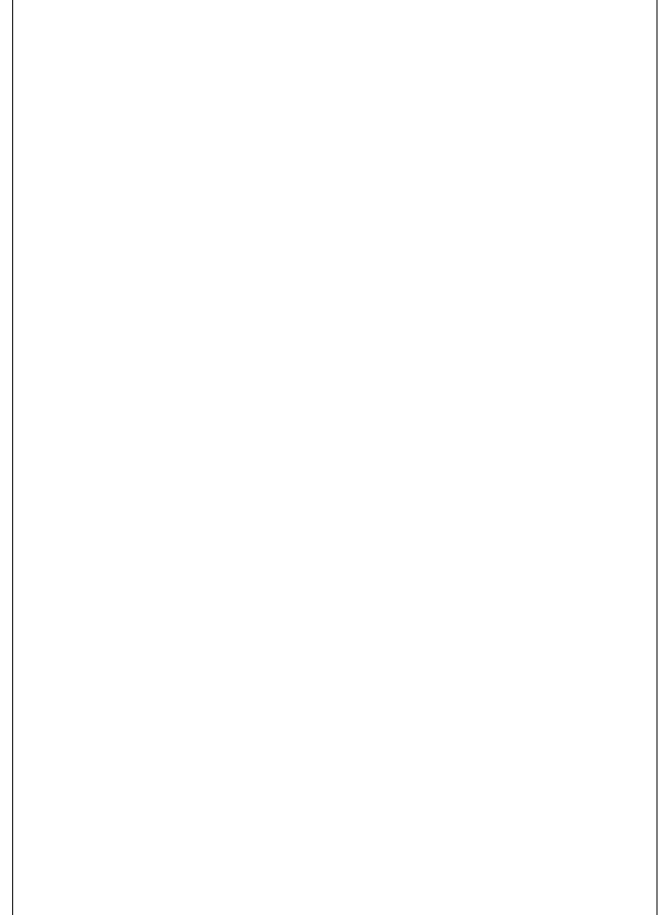
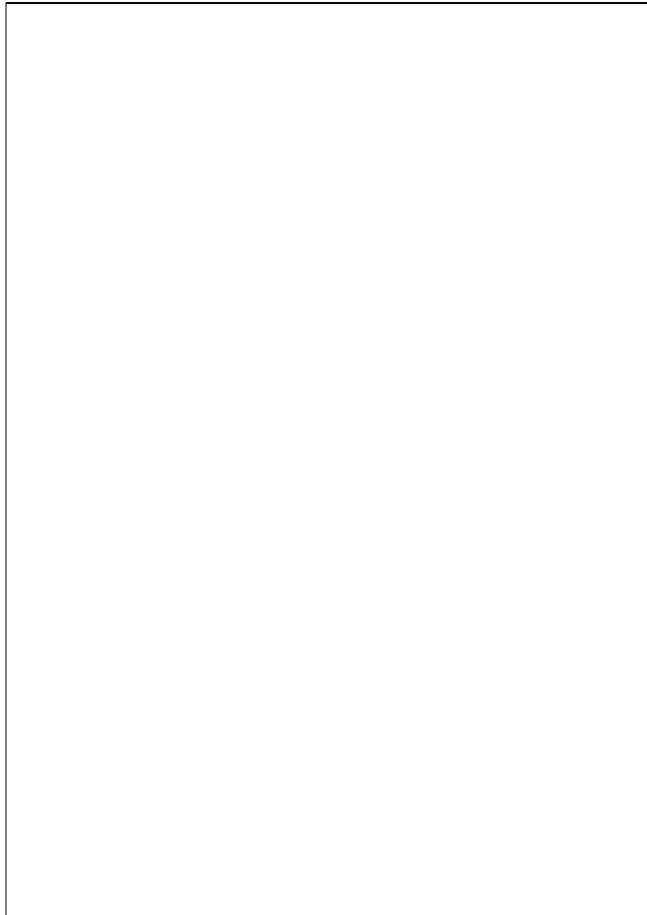
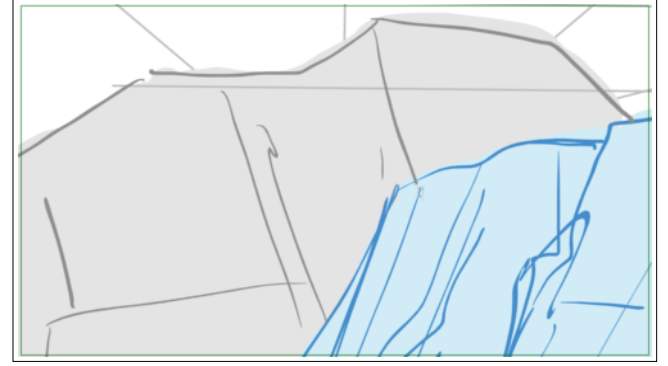
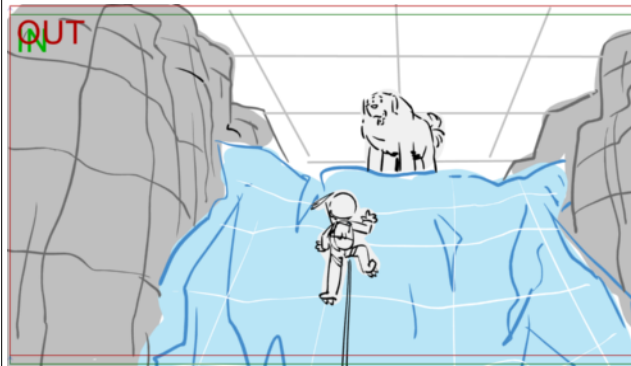
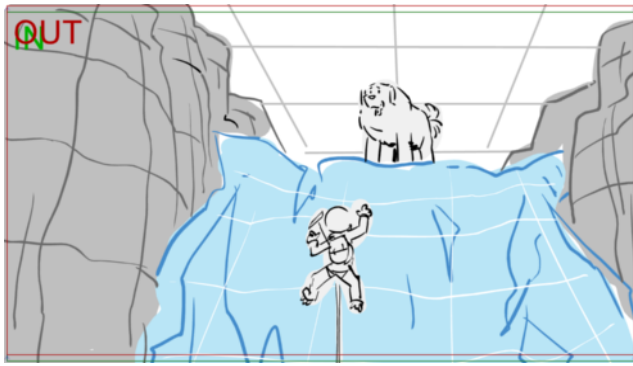

Scene	Duration	Panel	Duration
108_B	04:12	2	00:07

Scene	Duration	Panel	Duration
108_B	04:12	3	00:13

NO PANEL

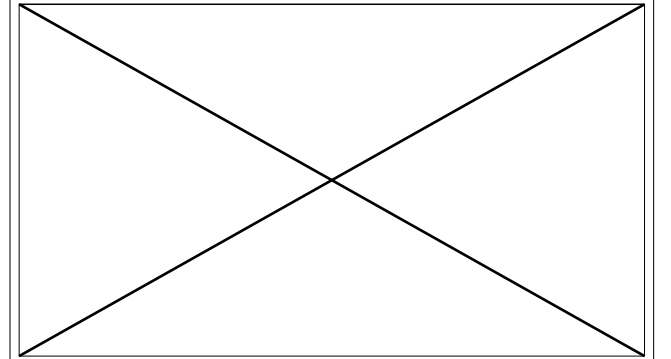
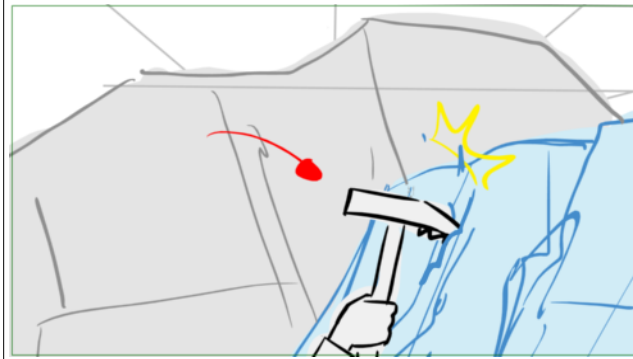
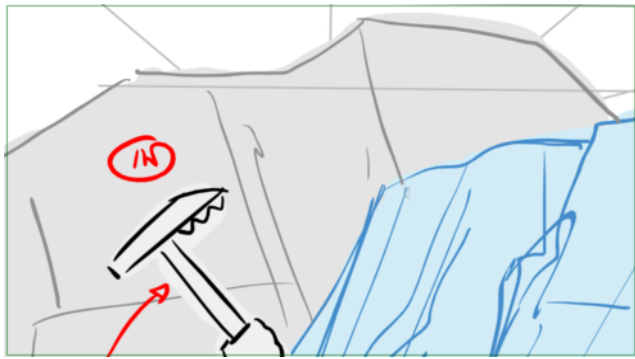

**Action Notes**  
 Main de SEB IN plante le piolet dans la glace

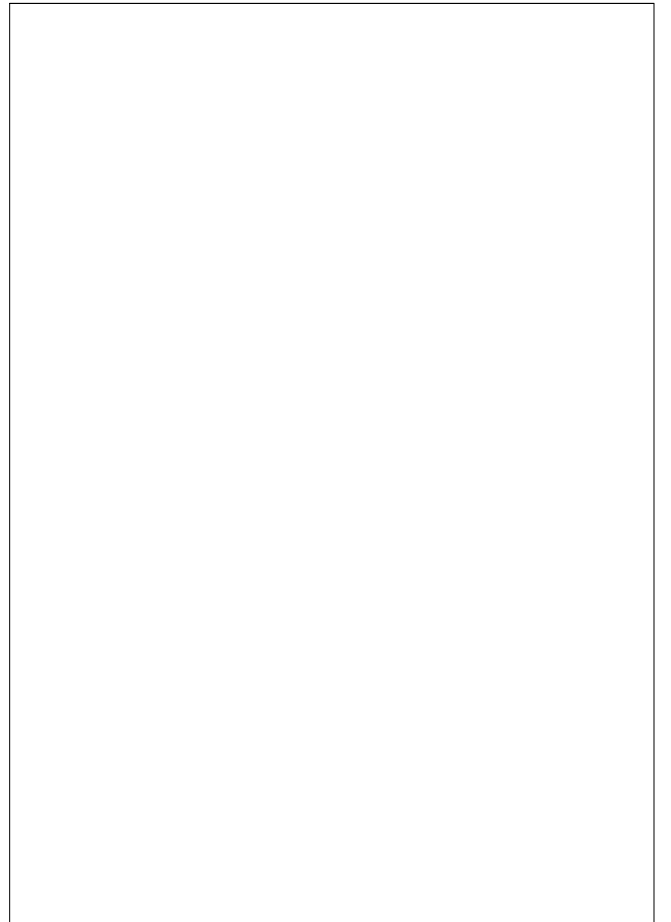
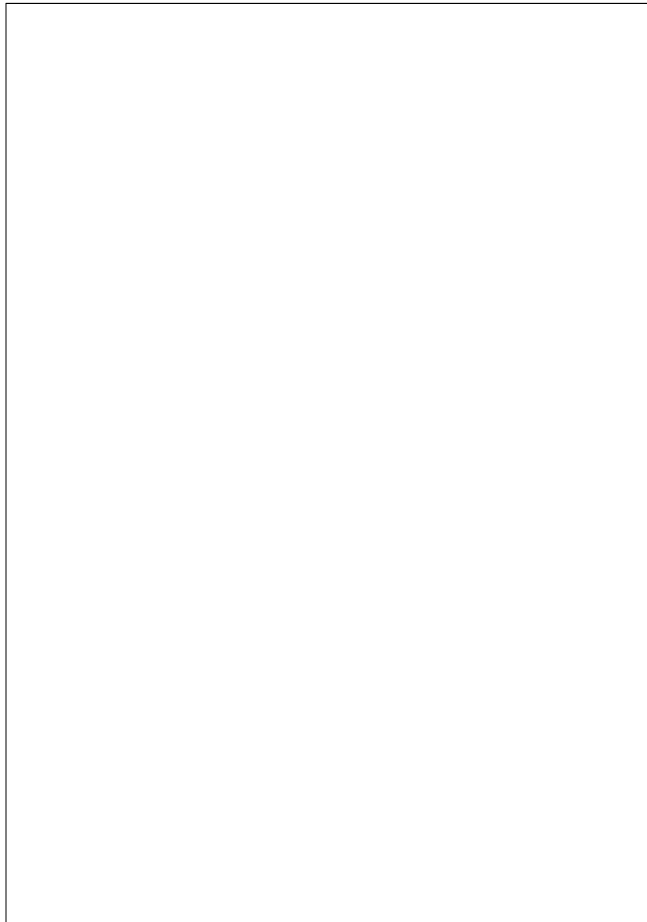



Scene	Duration	Panel	Duration
108_B	04:12	4	01:00

NO PANEL

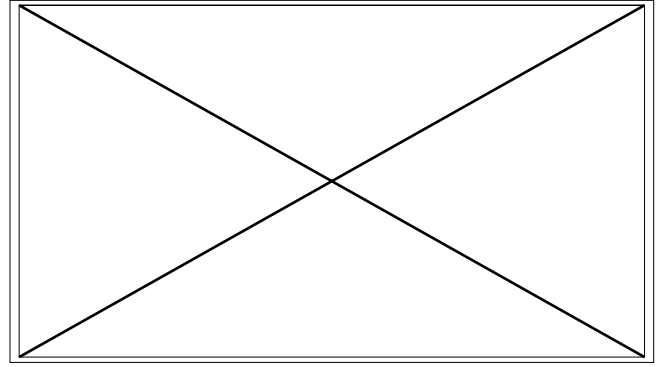
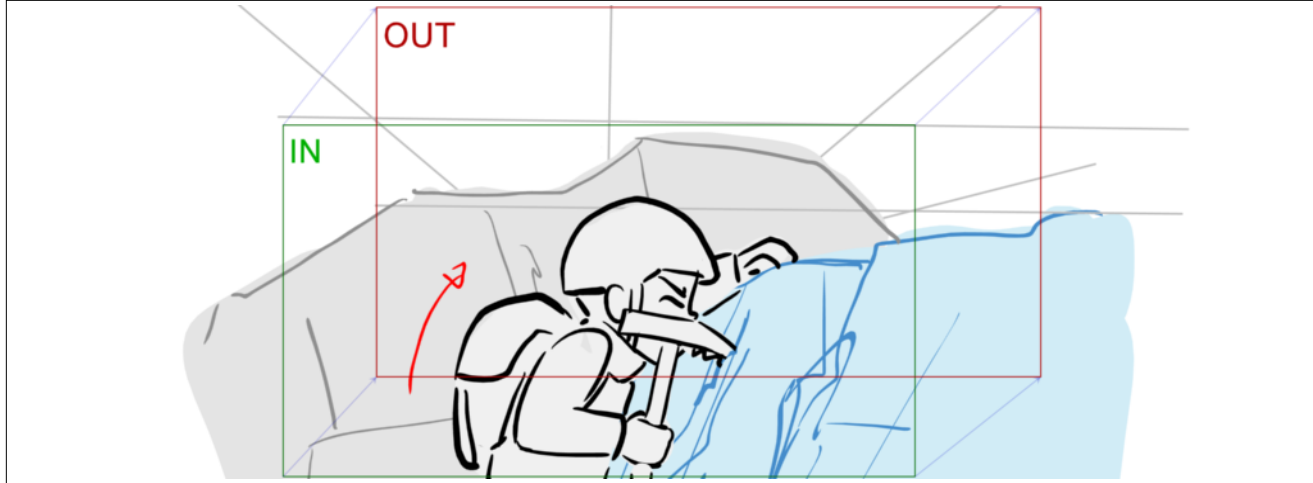

**Action Notes**

SEB s'appuie dessus et grimpe

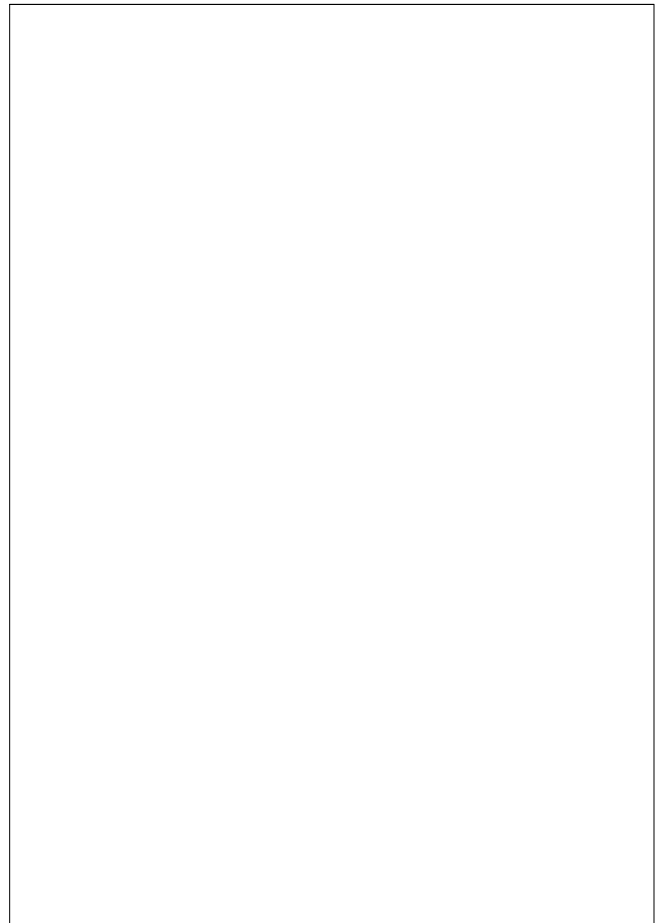

Scene	Duration	Panel	Duration
108_B	04:12	5	00:12

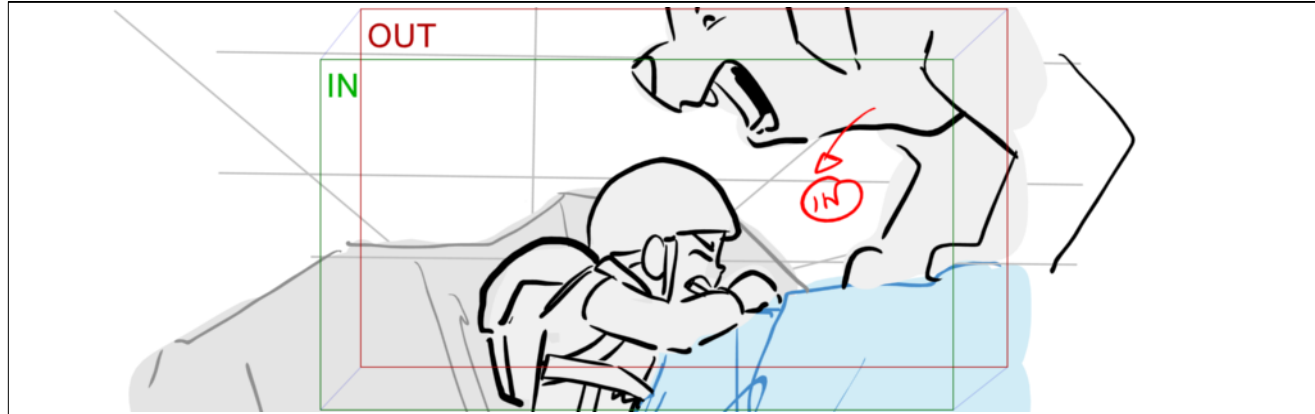

**Action Notes**

Belle prend le pull de Seb dans sa gueule et tire

Scene	Duration	Panel	Duration
108_B	04:12	6	00:15

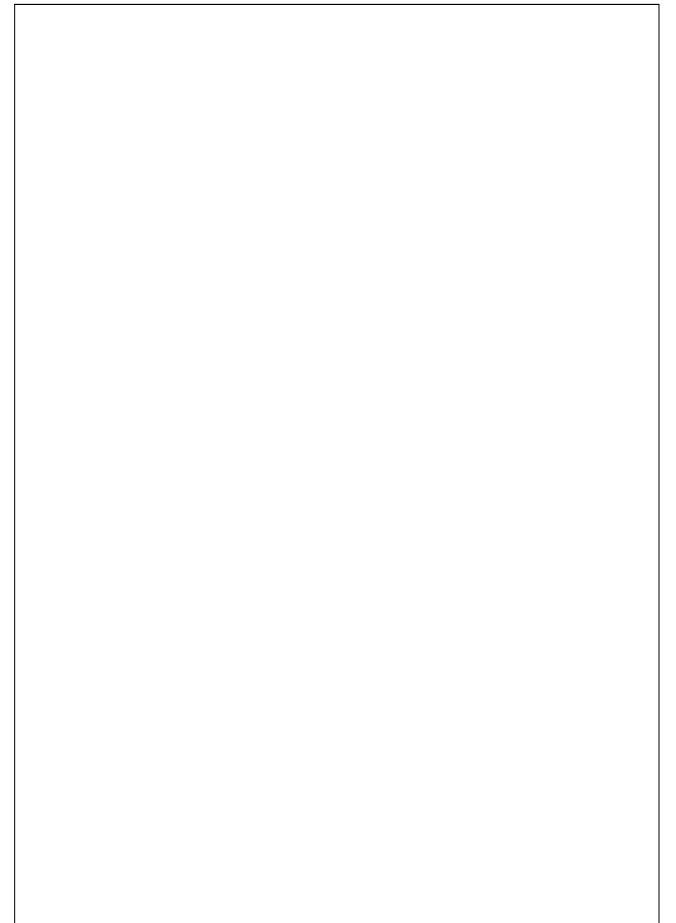
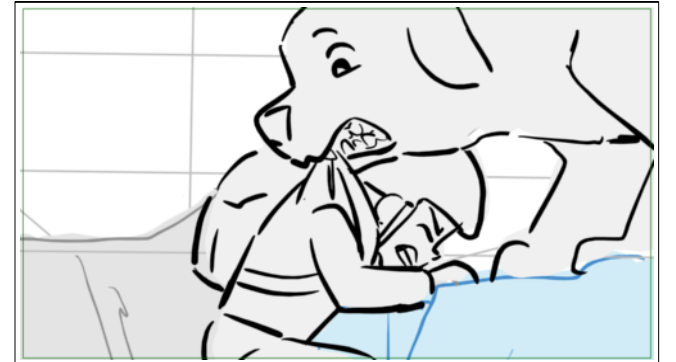



Scene	Duration	Panel	Duration
108_B	04:12	7	00:15

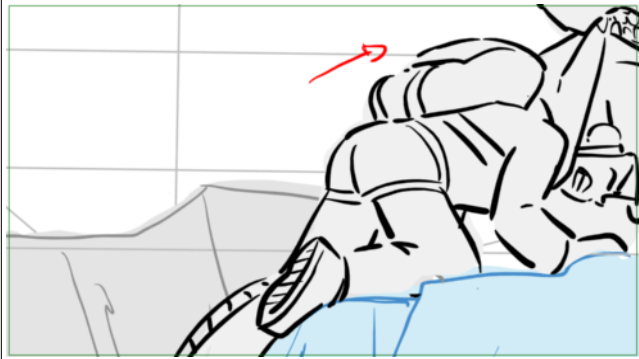

Scene	Duration	Panel	Duration
108_B	04:12	8	00:12

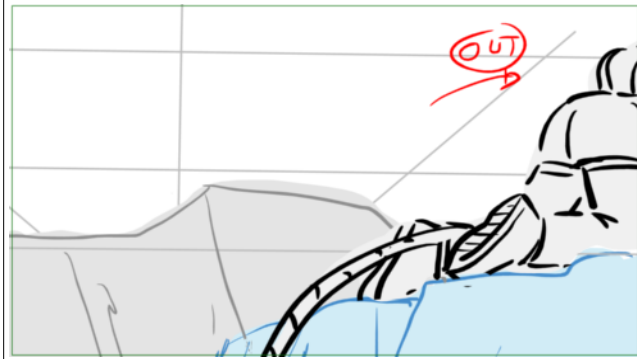

Scene	Duration	Panel	Duration
125	06:17	1	00:13



**Action Notes**

Belle aide SEB à se mettre à se mettre en sécurité

Scene	Duration	Panel	Duration
125	06:17	2	00:13

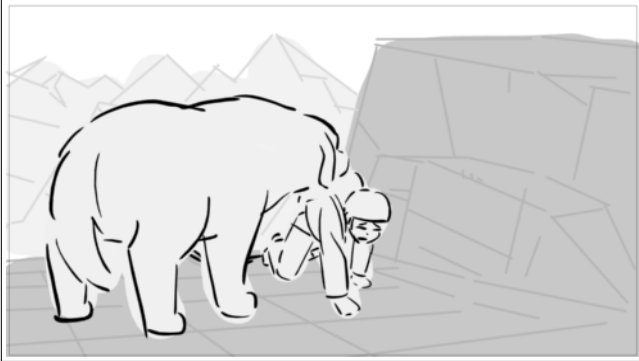

Scene	Duration	Panel	Duration
125	06:17	3	01:17

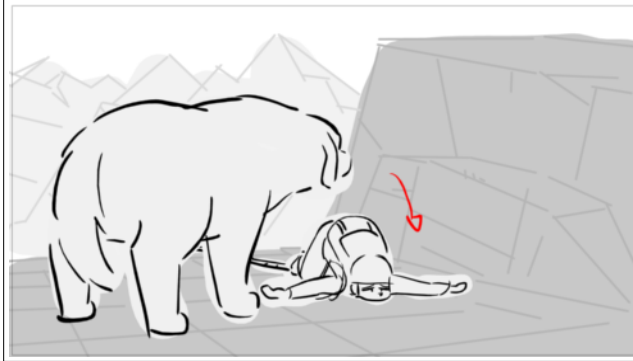

**Action Notes**  
SEB s'écroule

Scene	Duration	Panel	Duration
125	06:17	4	01:01

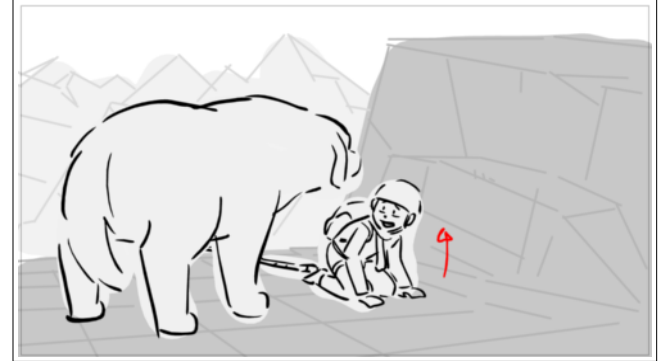

Scene	Duration	Panel	Duration
125	06:17	5	01:15

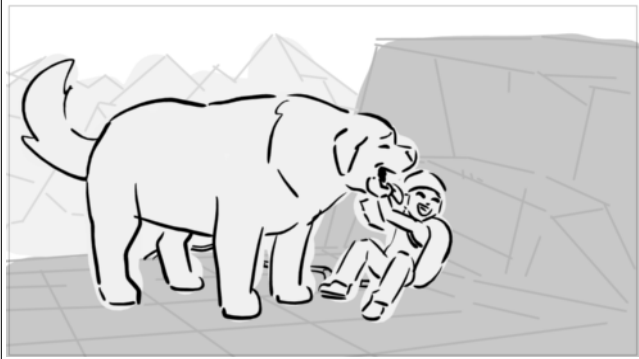

**Dialogue**  
 PU SEBASTIEN  
 Merci Belle!

**Action Notes**  
 Belle lèche le visage de SEB

Scene	Duration	Panel	Duration
125	06:17	6	00:15



**Dialogue**  
 PU SEBASTIEN  
 ça va mieux maintenant

**Action Notes**  
 SEB détache la corde de son baudrier

Scene	Duration	Panel	Duration
125	06:17	7	00:18



**Dialogue**  
 PU SEBASTIEN  
 ça va mieux maintenant

**Action Notes**  
 SEB détache la corde de son baudrier

Scene	Duration	Panel	Duration
109_A	04:10	1	00:17

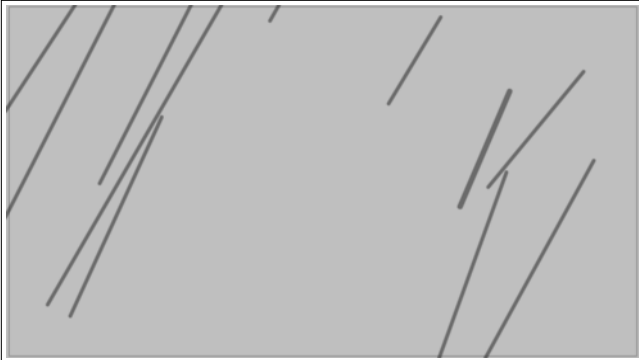

Scene	Duration	Panel	Duration
109_A	04:10	2	00:17



**Action Notes**  
 Main de SEB IN positionne un piton sur le rocher

Scene	Duration	Panel	Duration
109_A	04:10	3	00:11

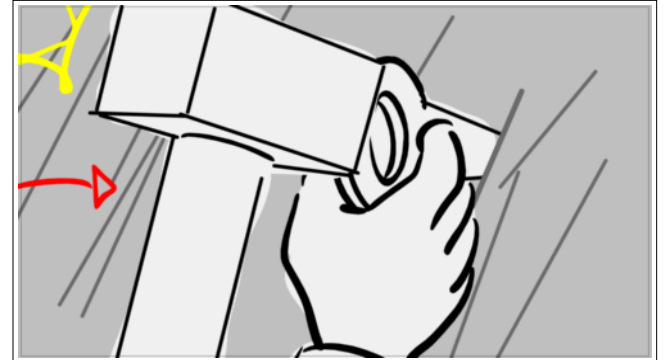

**Action Notes**  
 marteau IN enfonce le piton

Scene	Duration	Panel	Duration
109_A	04:10	4	00:09



Scene	Duration	Panel	Duration
109_A	04:10	5	00:10

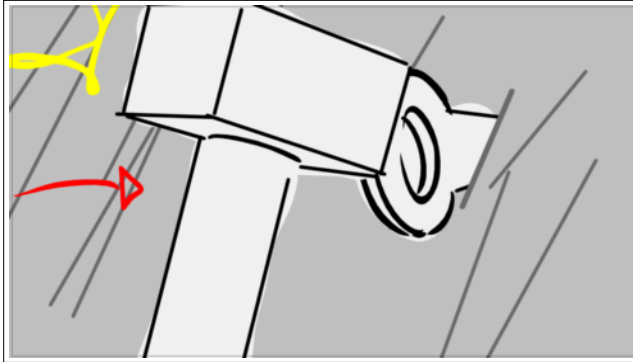

Scene	Duration	Panel	Duration
109_A	04:10	6	00:04

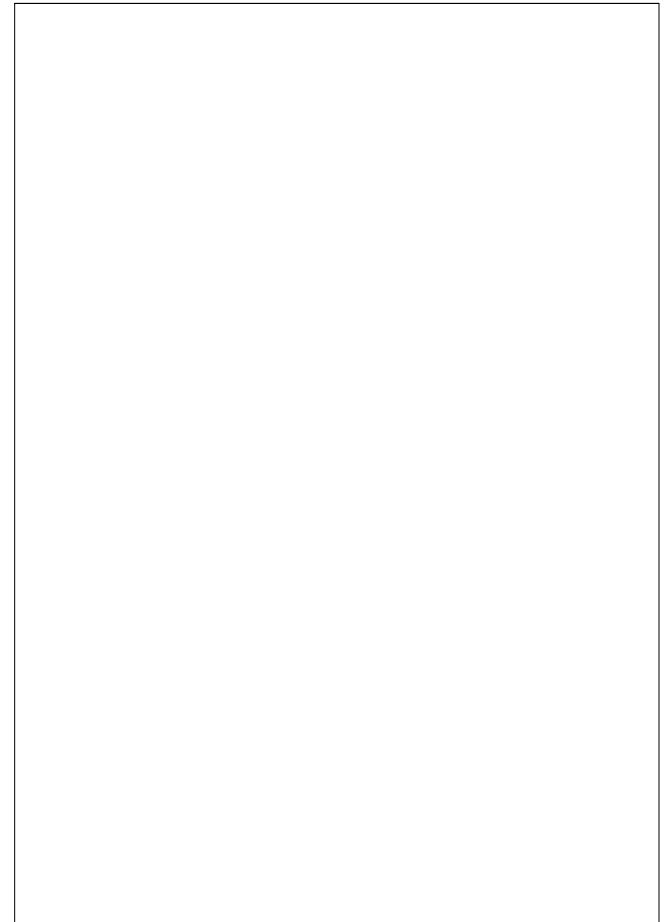
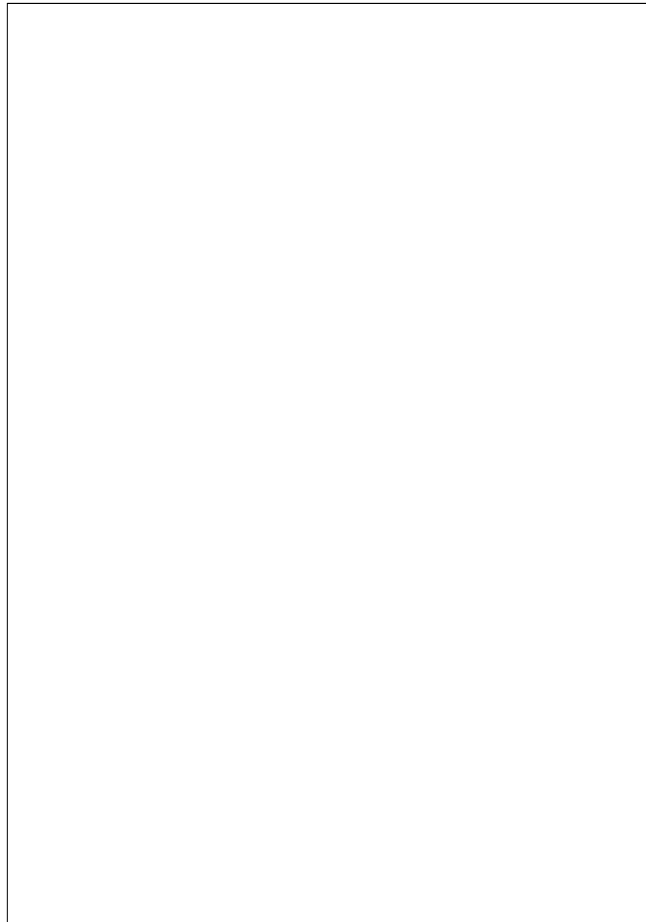
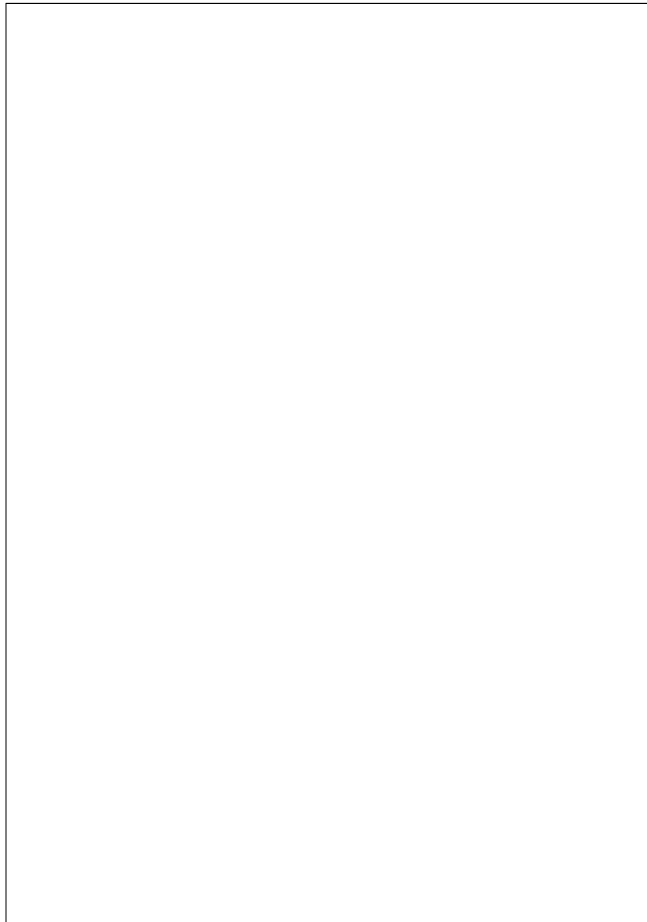
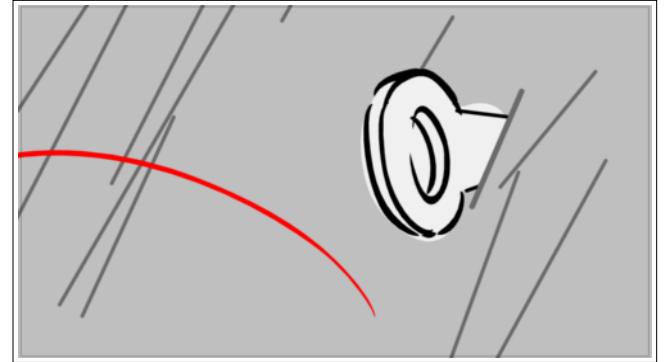

Scene	Duration	Panel	Duration
109_A	04:10	7	00:14

Scene	Duration	Panel	Duration
109_A	04:10	8	00:14

Scene	Duration	Panel	Duration
109_A	04:10	9	00:14

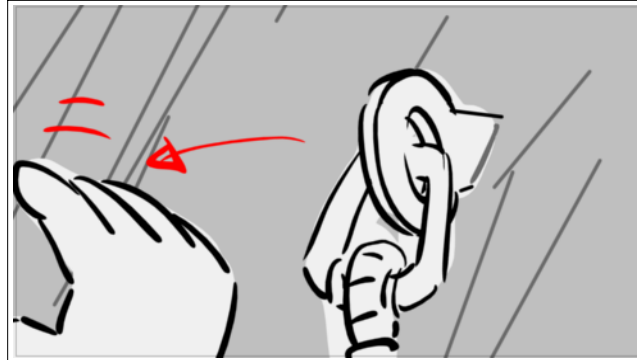
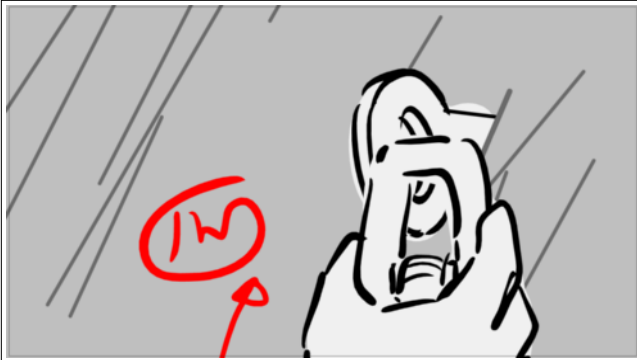

**Action Notes**

Main IN attache le mousqueton avec la corde détachée du baudrier

Scene	Duration	Panel	Duration
125_A	03:07	1	00:13



**Action Notes**

SEB vérifie la solidité du dispositif

Scene	Duration	Panel	Duration
125_A	03:07	2	00:07

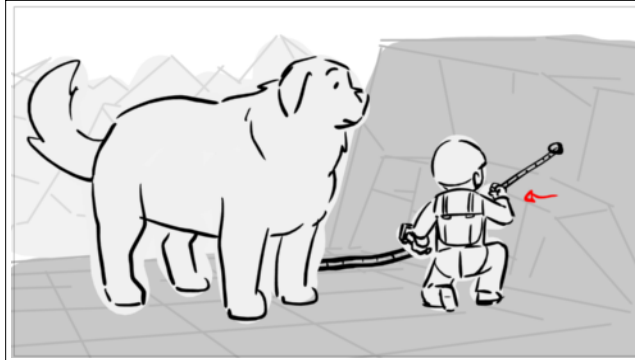

**Dialogue**

PU SEBASTIEN  
Et voilà!

Scene	Duration	Panel	Duration
125_A	03:07	3	00:07

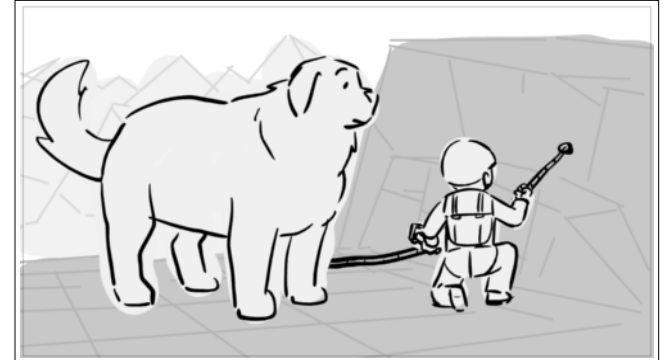

**Dialogue**

PU SEBASTIEN  
Et voilà!

Scene	Duration	Panel	Duration
125_A	03:07	4	00:07

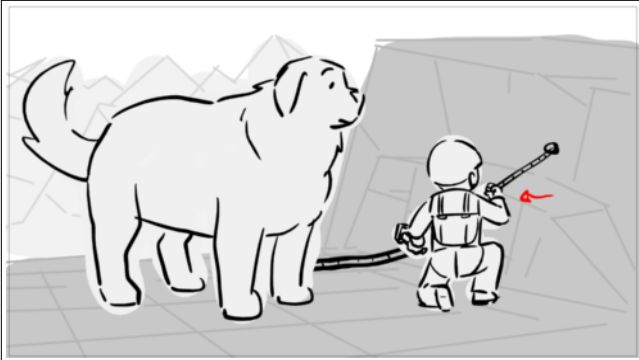

**Dialogue**  
 PU SEBASTIEN  
 Et voilà!

Scene	Duration	Panel	Duration
125_A	03:07	5	00:13

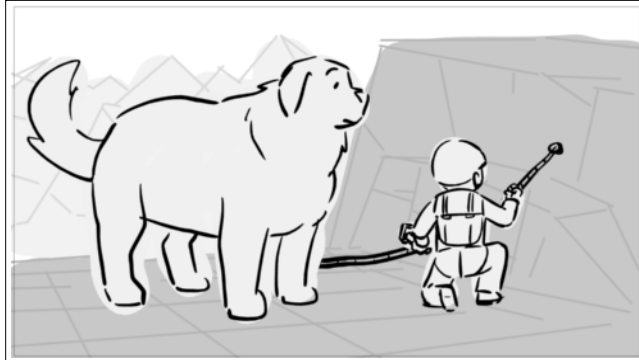

**Dialogue**  
 PU SEBASTIEN  
 Et voilà!

Scene	Duration	Panel	Duration
125_A	03:07	6	01:10



**Dialogue**  
 PU SEBASTIEN  
 Comme ça on pourra redescendre tout à l'heure!



Scene	Duration	Panel	Duration
126	05:03	1	00:09



**Dialogue**  
84. SÉBASTIEN  
Allez,

Scene	Duration	Panel	Duration
126	05:03	2	00:09

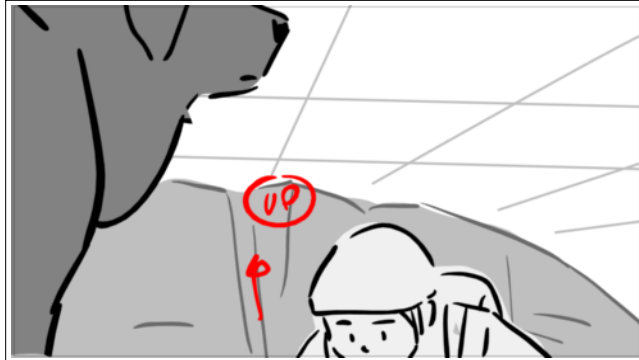

**Action Notes**  
SEB IN UP

Scene	Duration	Panel	Duration
126	05:03	3	01:18



**Dialogue**  
84. SÉBASTIEN  
Allez,

Scene	Duration	Panel	Duration
126	05:03	4	00:17



**Action Notes**  
SEb vacille

Scene	Duration	Panel	Duration
126	05:03	5	00:19



Scene	Duration	Panel	Duration
126	05:03	6	01:06



**Dialogue**  
85. SÉBASTIEN (panique un peu)  
Wow...

Scene	Duration	Panel	Duration
127	01:22	1	00:09



**Dialogue**

85. SÉBASTIEN (panique un peu)  
 Qu'est-ce qu'y s'passe là ?

Scene	Duration	Panel	Duration
127	01:22	2	00:17

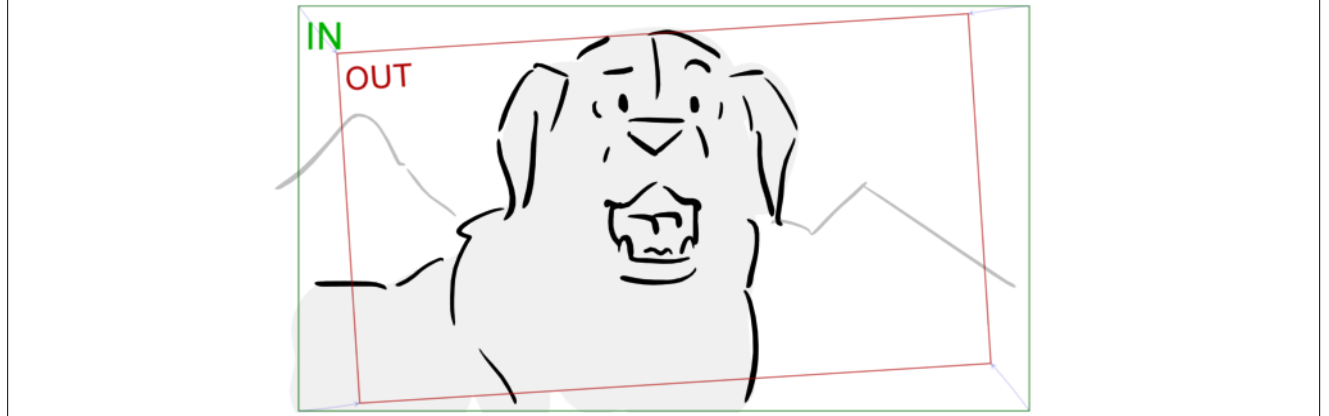

**Dialogue**

86. BELLE  
 (très inquiète maintenant) Wouf !

**Action Notes**

TRK IN

Scene	Duration	Panel	Duration
127	01:22	3	00:21

Scene	Duration	Panel	Duration
128	03:21	1	00:12

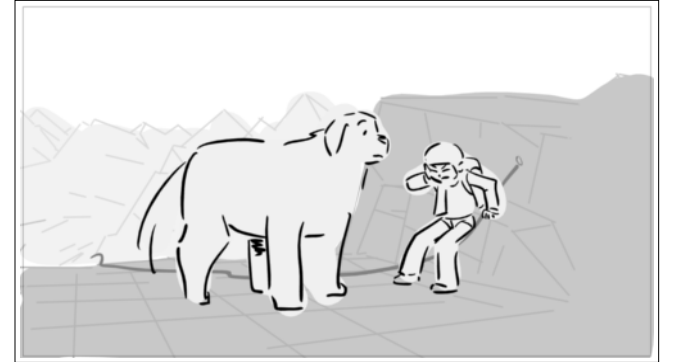
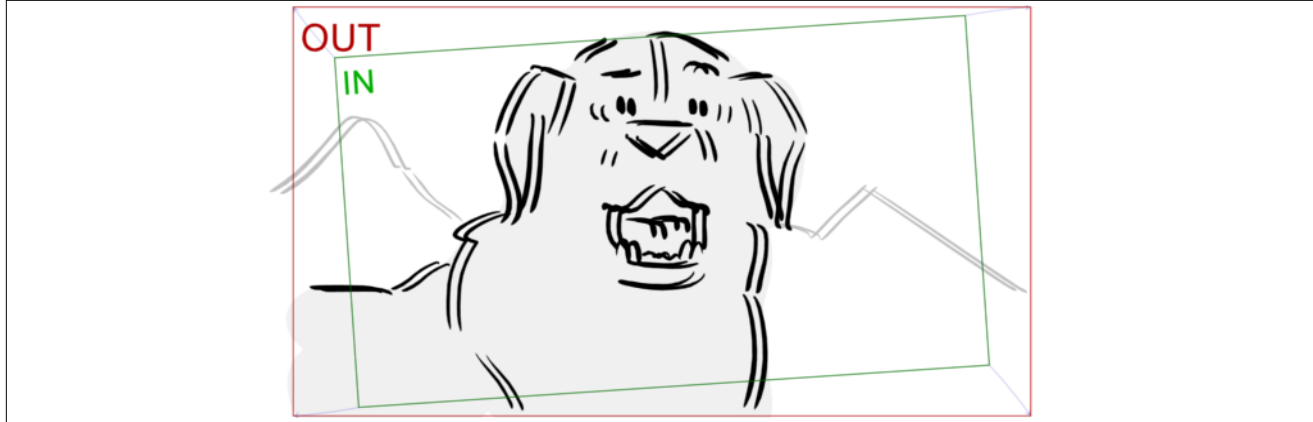

**Dialogue**  
 86. BELLE  
 (très inquiète maintenant) Wouf !

**Action Notes**  
 TRK OUT  
 BLUR IN

Scene	Duration	Panel	Duration
128	03:21	2	00:13

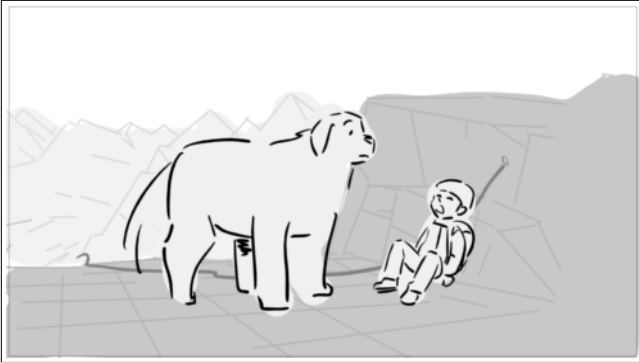

**Action Notes**

SEB s'effondre

Scene	Duration	Panel	Duration
128	03:21	3	01:17

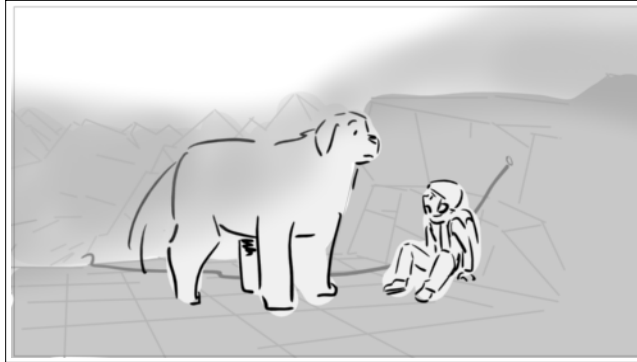

**Dialogue**

85. SÉBASTIEN (panique un peu)  
Je sens plus mes jambes !

**Action Notes**

BRUME IN

Scene	Duration	Panel	Duration
128	03:21	4	01:04





Scene	Duration	Panel	Duration
129	02:09	1	02:09

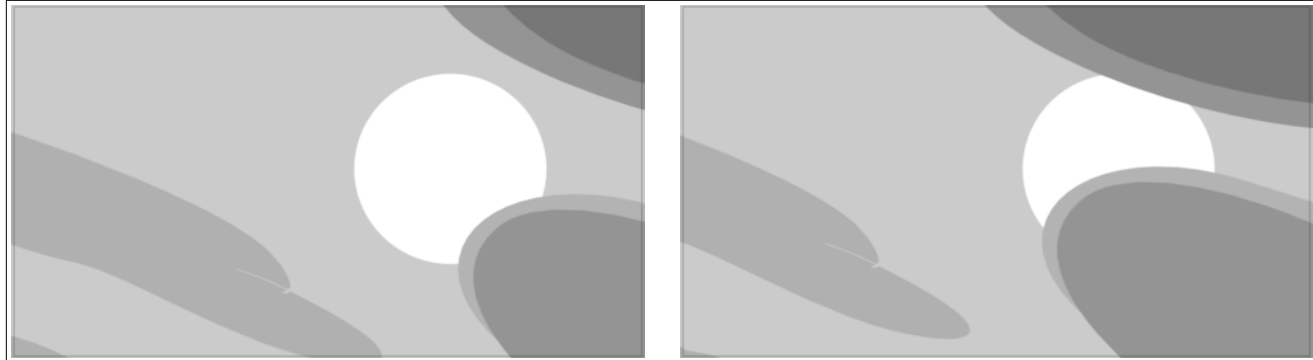

Scene	Duration	Panel	Duration
130	01:21	1	00:13



**Notes**  
FX SUN  
FX CLOUDS



Scene	Duration	Panel	Duration
130	01:21	2	00:19

Scene	Duration	Panel	Duration
130	01:21	3	00:14

NO PANEL

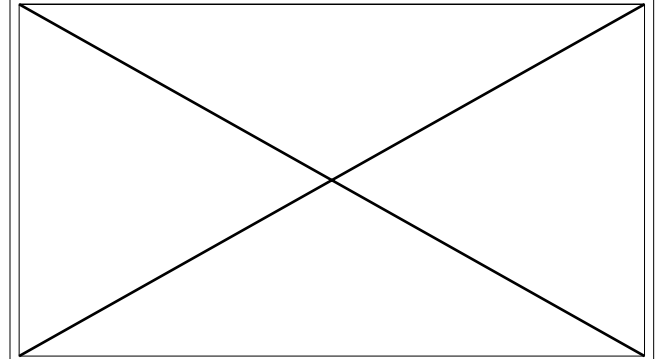
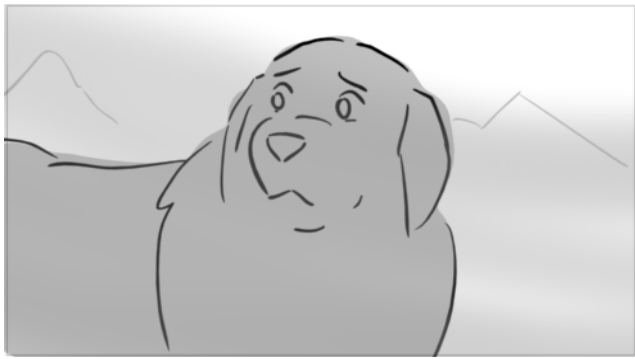

**Action Notes**  
BELLE regarde autour d'elle inquiète

Scene	Duration	Panel	Duration
131	01:22	1	01:22

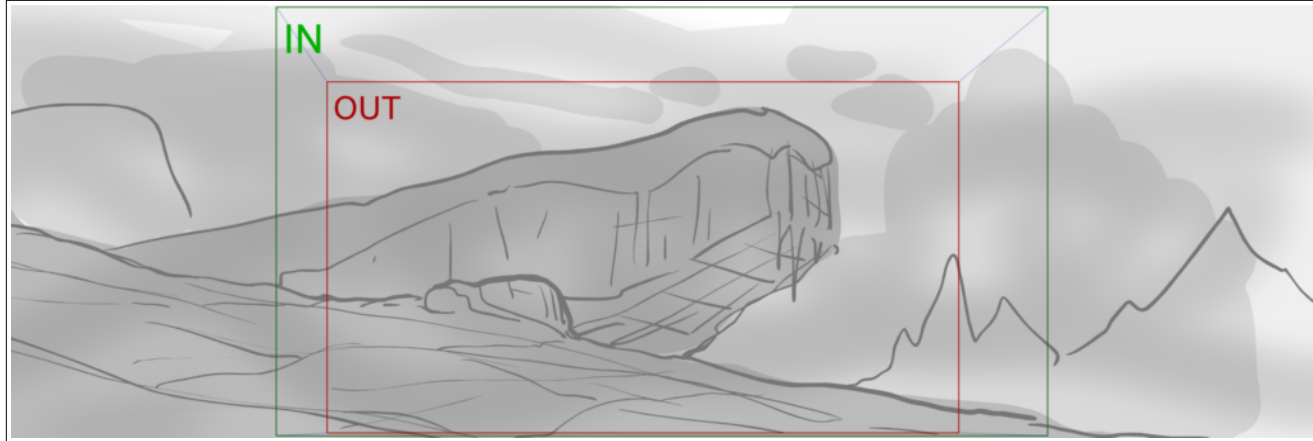

**Action Notes**

POV BELLE  
Un abri sous un rocher

Scene	Duration	Panel	Duration
132	03:21	1	00:18

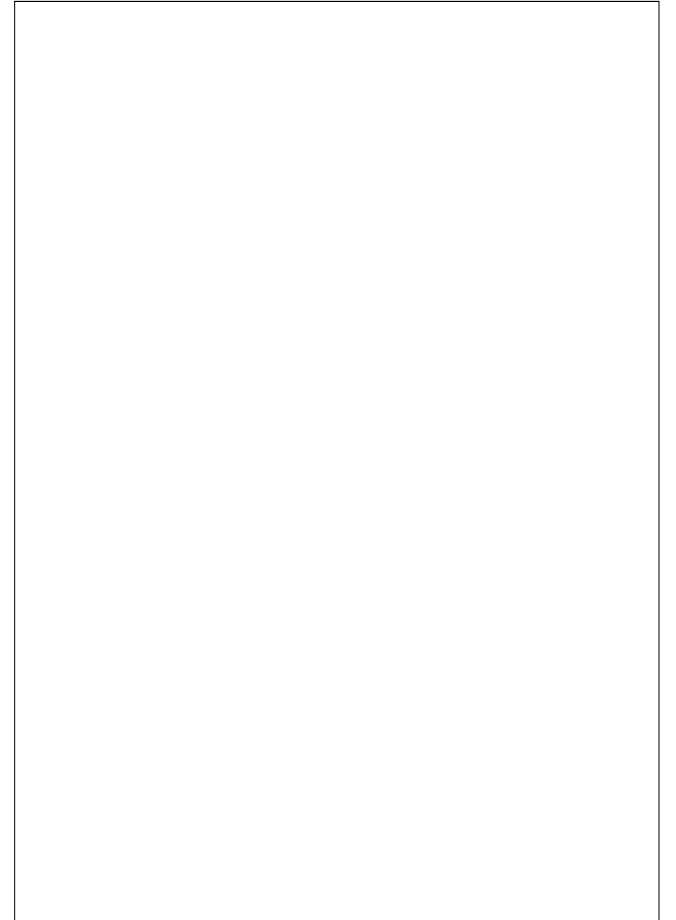



Scene	Duration	Panel	Duration
132	03:21	2	00:14

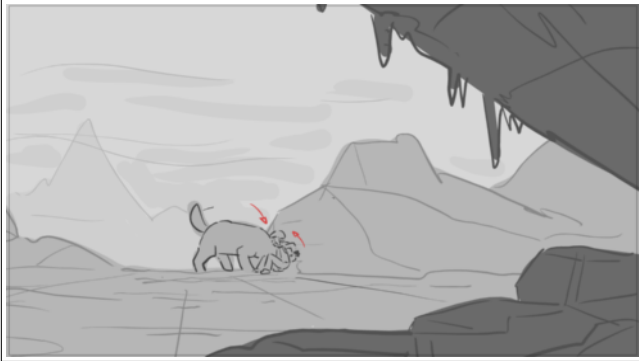

**Action Notes**

Belle aide SEB à se relever

Scene	Duration	Panel	Duration
132	03:21	3	00:11



**Dialogue**

87. SÉBASTIEN  
Qu'est-ce que tu fais ?

Scene	Duration	Panel	Duration
132	03:21	4	00:10

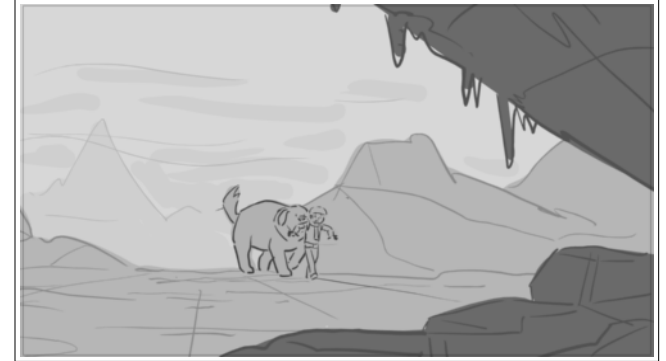

**Dialogue**

87. SÉBASTIEN  
Qu'est-ce que tu fais ?

**Action Notes**

Et le pousse vers l'abri

Scene	Duration	Panel	Duration
132	03:21	5	01:18

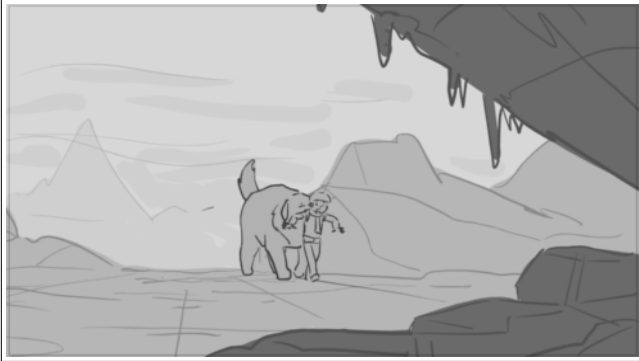

**Dialogue**

87. SÉBASTIEN  
 Qu'est-ce que tu fais ?

Scene	Duration	Panel	Duration
134	03:04	1	00:10



Scene	Duration	Panel	Duration
134	03:04	2	00:10



Scene	Duration	Panel	Duration
134	03:04	3	01:02

Scene	Duration	Panel	Duration
134	03:04	4	00:10

NO PANEL

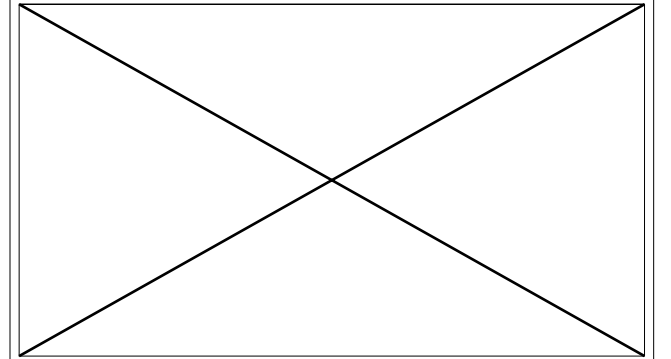

**Dialogue**

89. SÉBASTIEN (vaincu)  
On ne voit plus rien ma Belle.

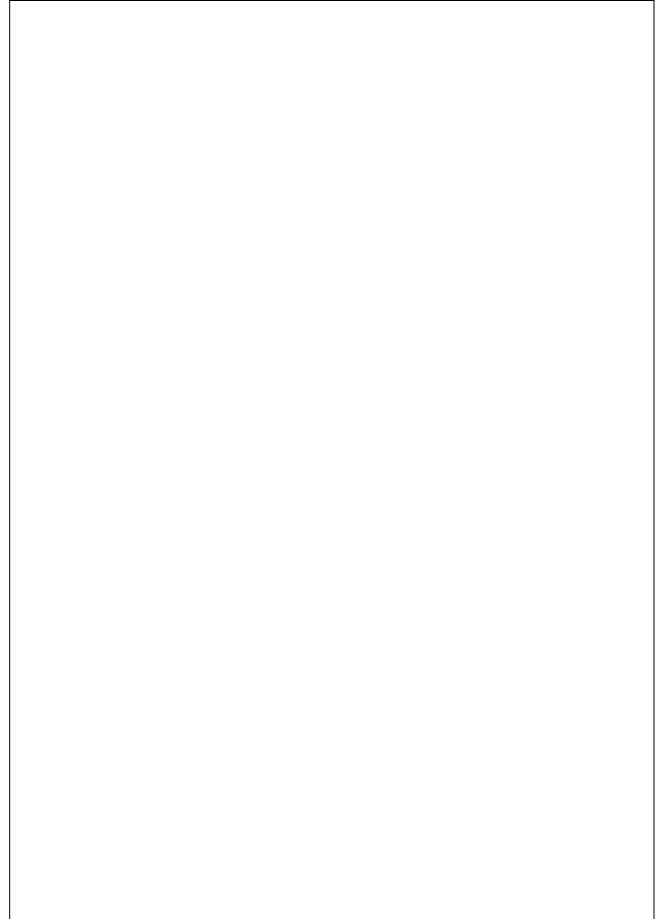



Scene	Duration	Panel	Duration
134	03:04	5	00:22

NO PANEL

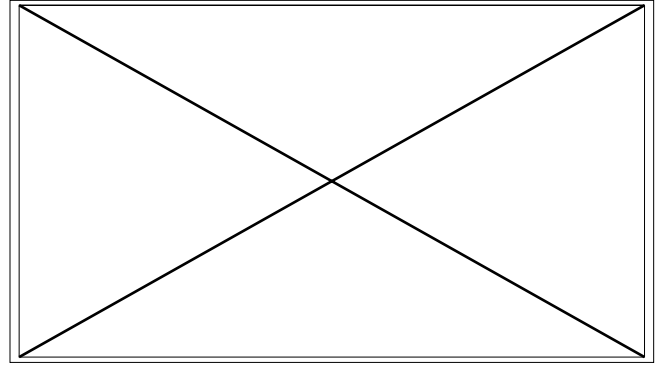
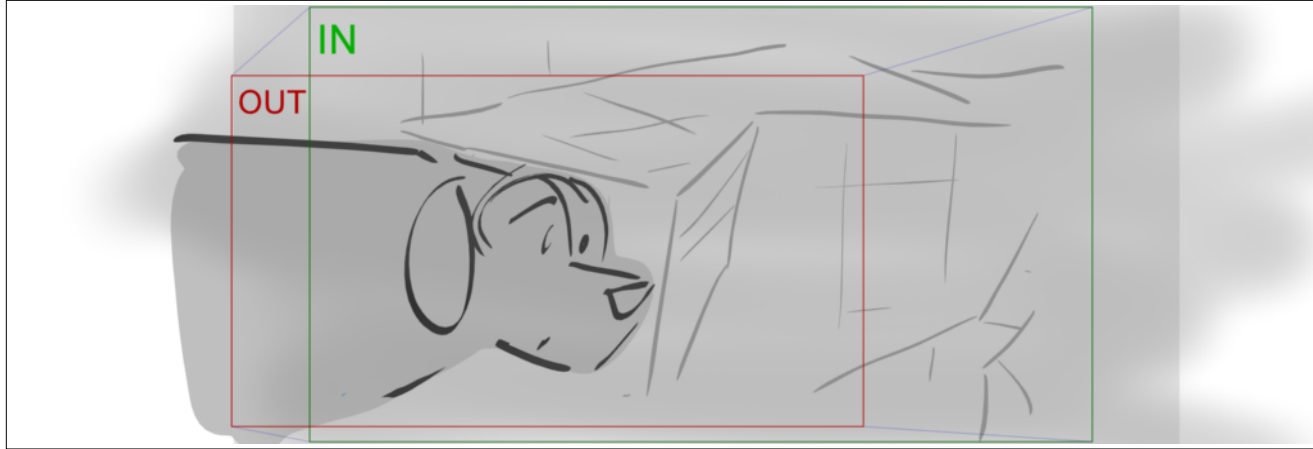

**Dialogue**

89. SÉBASTIEN

Même si on veut redescendre, va falloir attendre que la brume se lève...

Scene	Duration	Panel	Duration
135	06:06	1	06:06

**Dialogue**

89. SÉBASTIEN  
Si elle se lève un jour...  
88. BELLE  
(inquiète) < Couine ! >

Scene	Duration	Panel	Duration
136	05:18	1	00:09

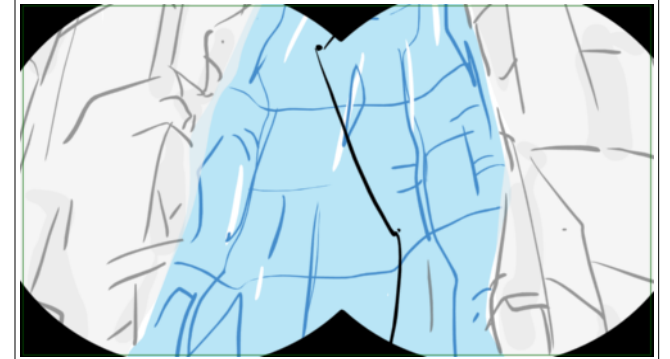
**Dialogue**

90. ANGELINA (regarde vers le haut)  
Je ne les vois toujours pas.

**Action Notes**

18. EXT - PIC SANS NOM, HAUTE ALTITUDE  
- JOUR  
En bas de la goulotte  
POV ANGELINA à travers les jumelles On  
voit la corde de sébastien

Scene	Duration	Panel	Duration
136	05:18	2	00:17

Scene	Duration	Panel	Duration
136	05:18	3	00:09

NO PANEL

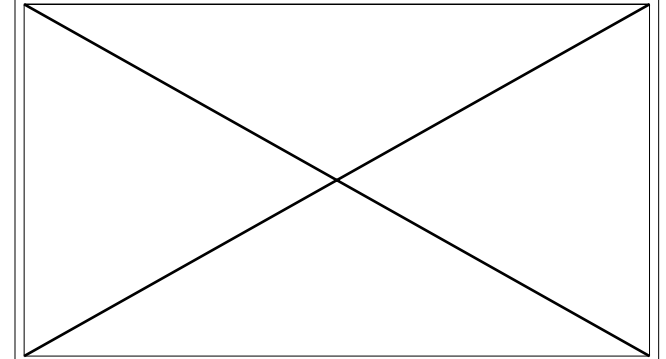
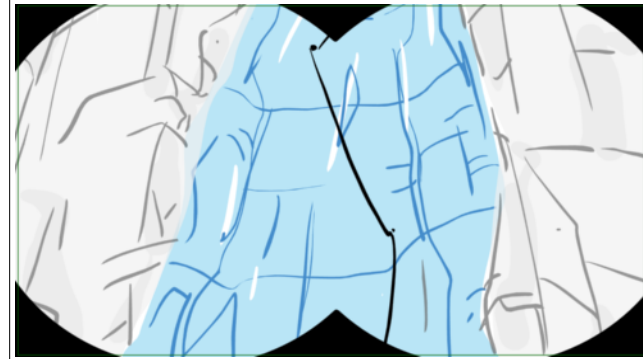
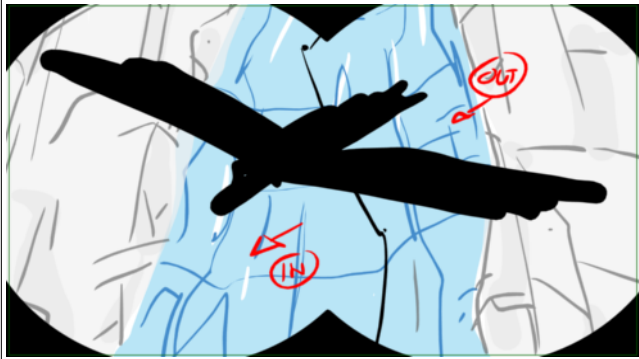

**Dialogue**  
 90. ANGELINA (regarde vers le haut)  
 Je ne les vois toujours pas.

**Dialogue**  
 90. ANGELINA (regarde vers le haut)  
 Je ne les vois toujours pas.

Scene	Duration	Panel	Duration
136	05:18	4	01:14

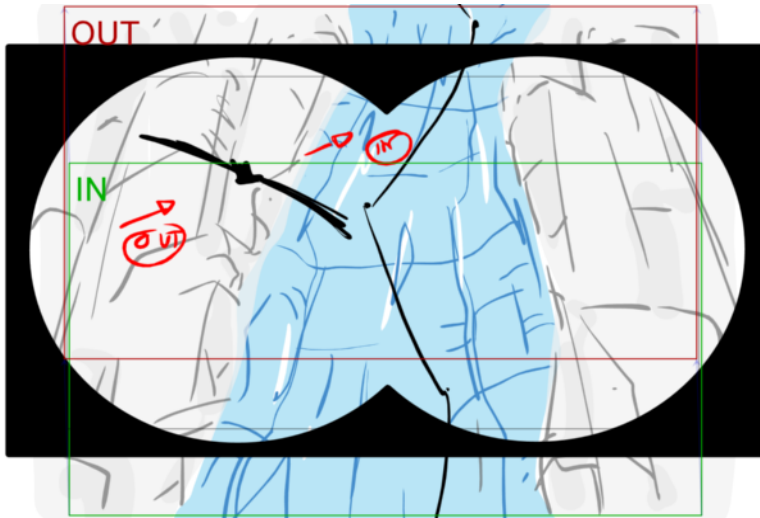
**Dialogue**

90. ANGELINA (regarde vers le haut)  
Je ne les vois toujours pas.

Scene	Duration	Panel	Duration
136	05:18	5	01:05

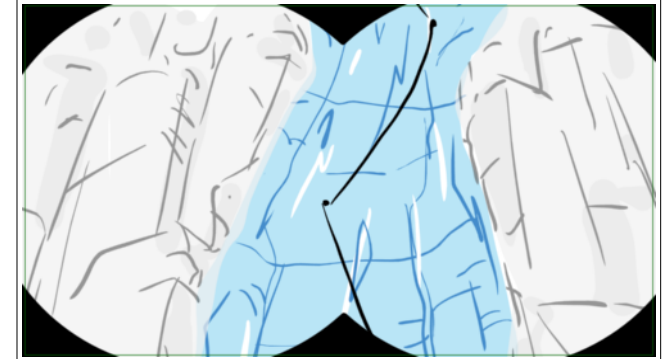
**Dialogue**

90. ANGELINA  
Ils ont dû monter drôlement vite !

Scene	Duration	Panel	Duration
136	05:18	6	00:13

Scene	Duration	Panel	Duration
136	05:18	7	01:01

Scene	Duration	Panel	Duration
137	04:16	1	00:08

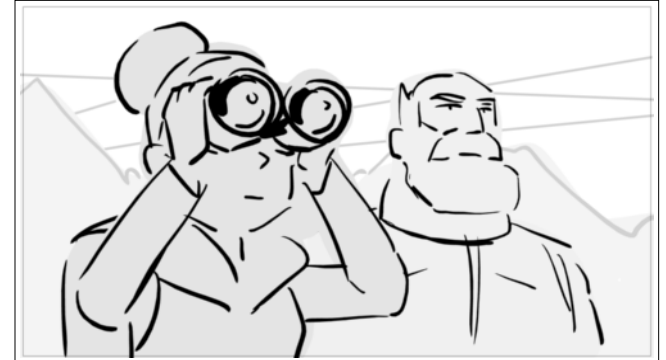
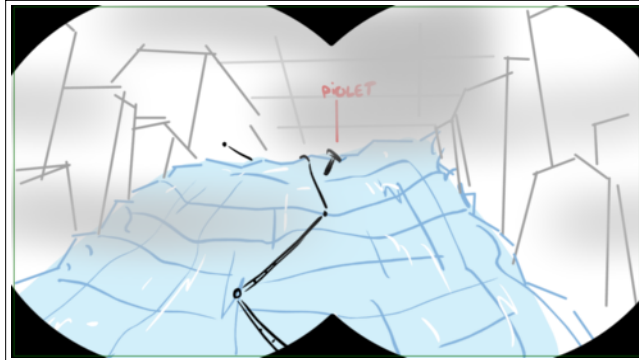
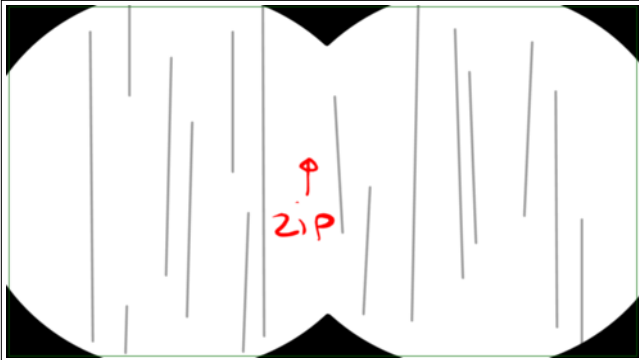

**Dialogue**  
 90. ANGELINA  
 Ils ont dû monter drôlement vite !

**Action Notes**  
 POV haut de la goulotte avec corde et piolet planté dans la glace  
 FX BRUME



Scene	Duration	Panel	Duration
137	04:16	2	00:14

Scene	Duration	Panel	Duration
137	04:16	3	03:19

NO PANEL

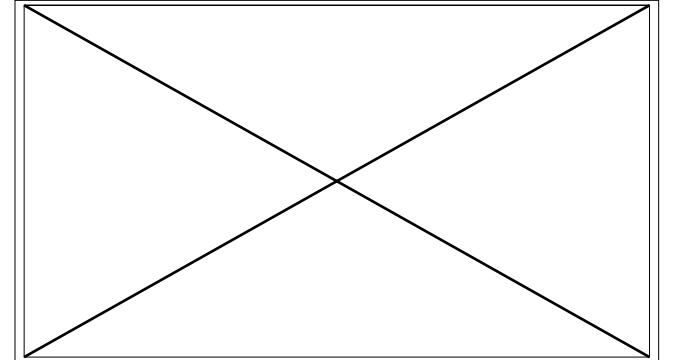

**Dialogue**  
 91. CÉSAR (très inquiet)  
 Trop vite !

Scene	Duration	Panel	Duration
138	02:10	1	02:10

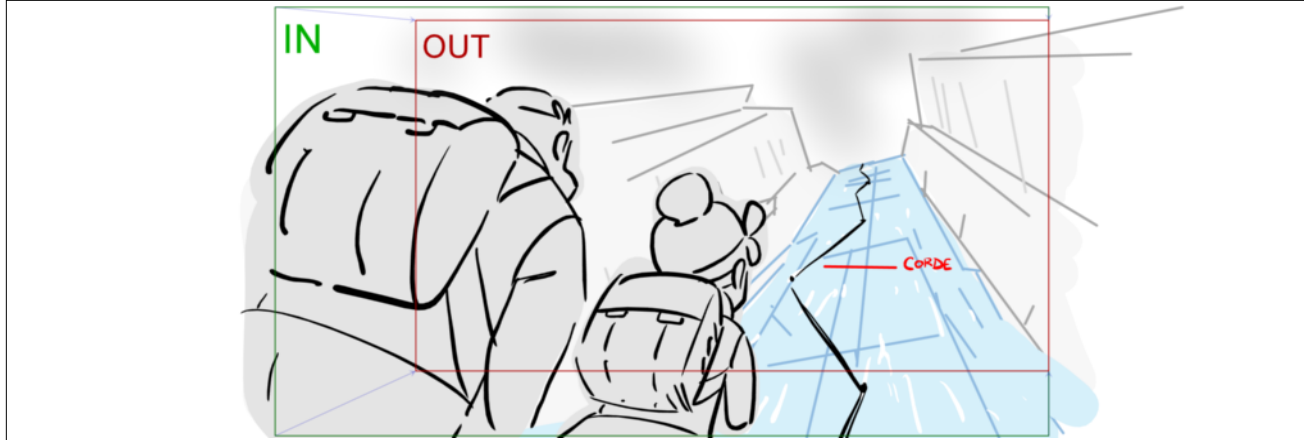
**Dialogue**

91. CÉSAR

A cette altitude, il faut faire très attention. Le mal des montagnes peut être fatal !

**Action Notes**

TRK IN vers le haut de la goulotte

FX brume

NO PANEL

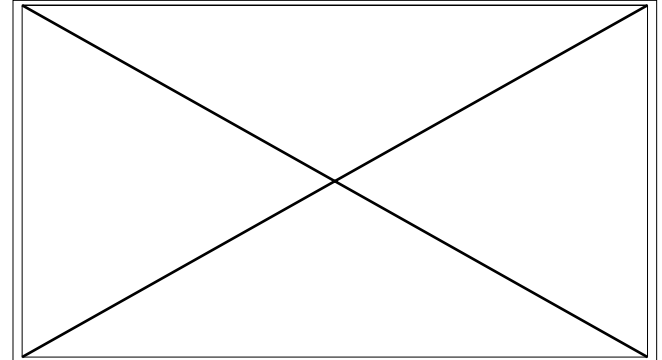

Scene	Duration	Panel	Duration
139	03:02	1	03:02

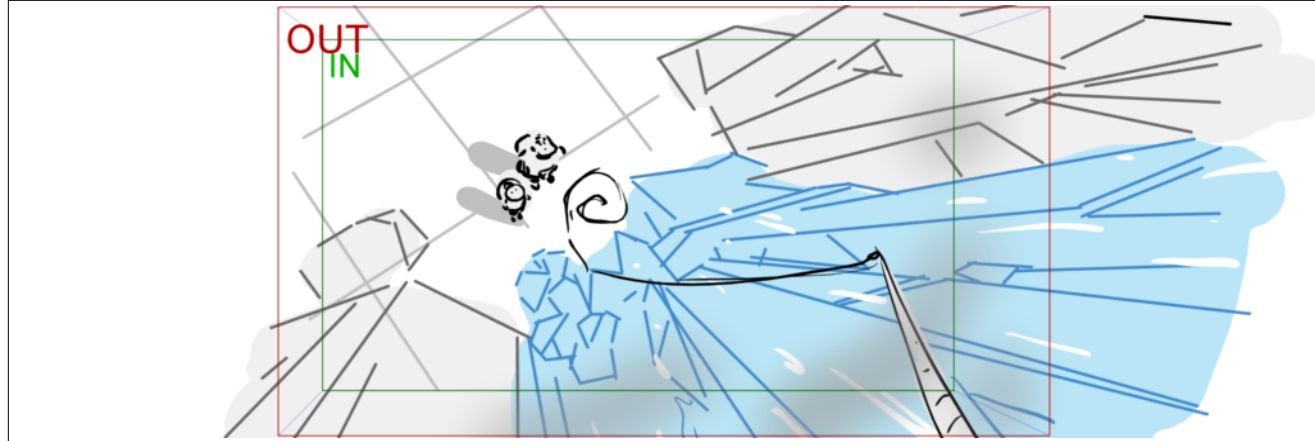

**Dialogue**

91. CÉSAR MODIF

On n'a pas le choix. On va suivre le même chemin qu'eux...

Scene	Duration	Panel	Duration
140	03:14	1	03:14

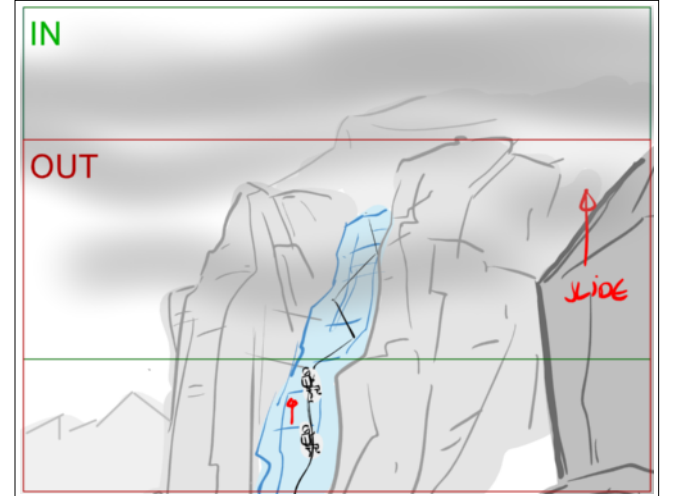

**Dialogue**

93. ANGELINA

SÉBASTIEN ?? BELLE ??

**Action Notes**

PAN DOWN

César et Angelina ascensionnent la goulotte grace à la corde laissée par SEB

FX brume sur le sommet

Scene	Duration	Panel	Duration
141	02:23	1	02:23

NO PANEL

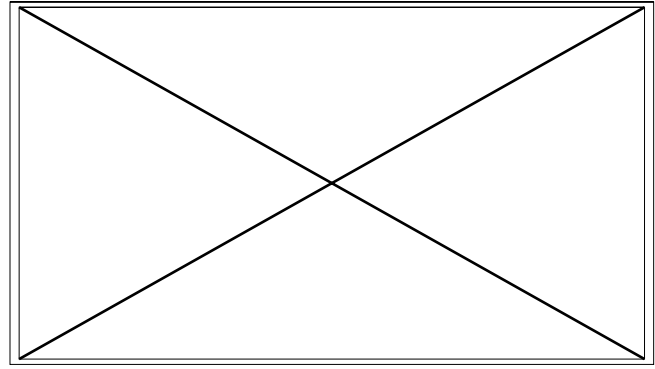

**Dialogue**  
 93. ANGELINA  
 SÉBASTIEN ?? BELLE ??

**Action Notes**  
 TRK OUT

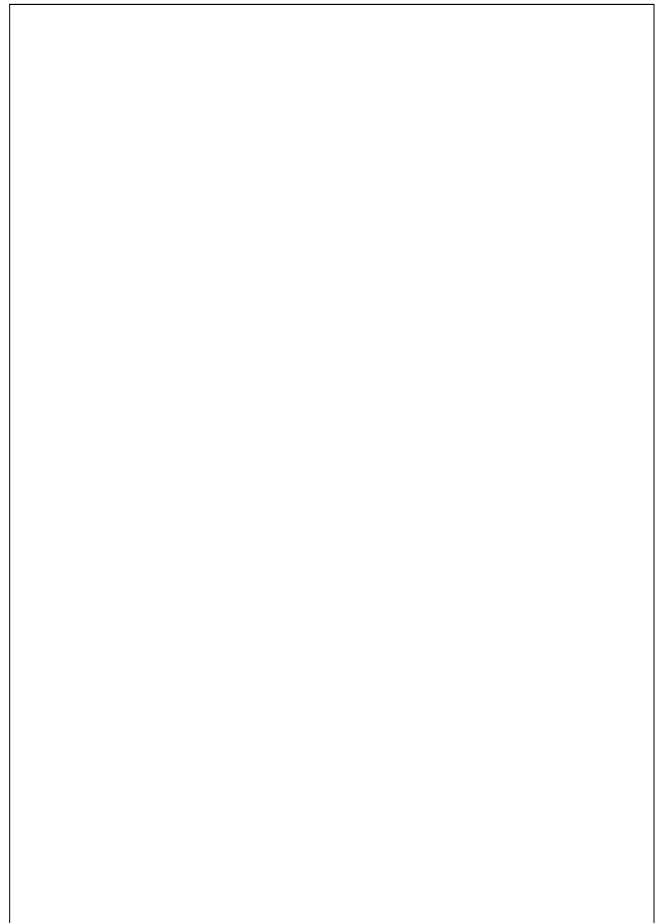

Scene	Duration	Panel	Duration
142	03:13	1	03:13

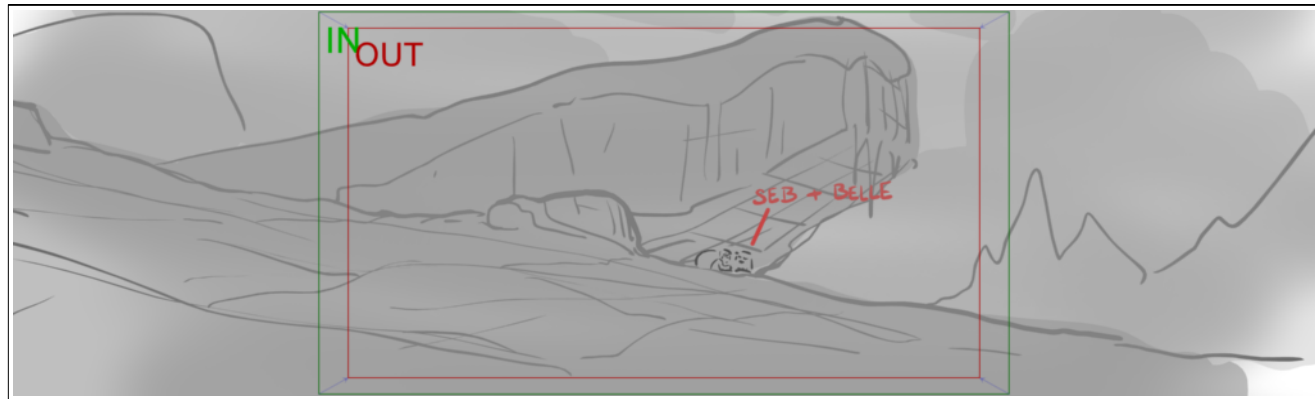

**Dialogue**

94. ANGELINA (ECHO)  
 ...ASTIEN ...ELLE

Scene	Duration	Panel	Duration
143	01:11	1	00:16

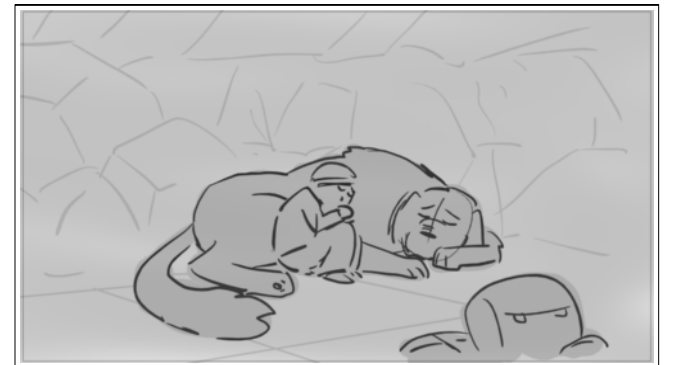

**Dialogue**

94. ANGELINA (ECHO)  
 ...ASTIEN ...ELLE

**Action Notes**

19. EXT - PIC SANS NOM, TRES HAUTE ALTITUDE - JOUR  
 TRK OUT  
 Belle et SEB à l'abri sous le rocher

**Action Notes**

SEB dort enroule dans Belle

Scene	Duration	Panel	Duration
143	01:11	2	00:20



**Dialogue**

94. ANGELINA (ECHO)  
...ASTIEN ...ELLE

**Action Notes**

B et S réagissent à la voix d'A

Scene	Duration	Panel	Duration
144	01:15	1	00:22



Scene	Duration	Panel	Duration
144	01:15	2	00:18



**Dialogue**

95. BELLE  
(les appelle) Wouf. Wou wou wou wou.  
Wouf !

Scene	Duration	Panel	Duration
146	02:12	1	00:16



**Dialogue**

95. BELLE  
 (les appelle) Wouf. Wou wou wou wou.  
 Wouf !

**Action Notes**

C et A réagissent aux aboiements de Belle

Scene	Duration	Panel	Duration
146	02:12	2	00:23



**Dialogue**

96. ANGELINA  
 (espoir, à César) J'entends Belle !

Scene	Duration	Panel	Duration
146	02:12	3	00:23



**Dialogue**

PU ANGELINA  
 Là!

Scene	Duration	Panel	Duration
145	01:17	1	00:15

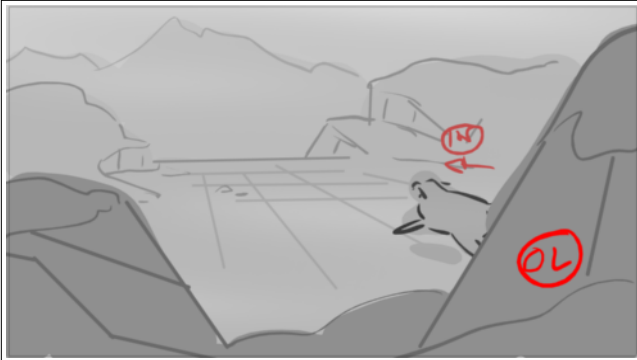

**Dialogue**  
 95. BELLE  
 (les appelle) Wouf. Wou wou wou wou.  
 Wouf !

Scene	Duration	Panel	Duration
145	01:17	2	00:15

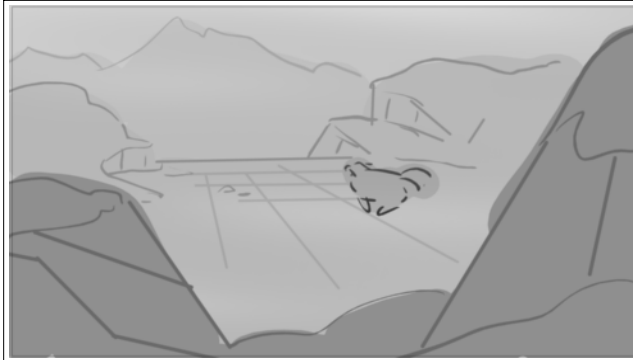

**Dialogue**  
 95. BELLE  
 (les appelle) Wouf. Wou wou wou wou.  
 Wouf !

Scene	Duration	Panel	Duration
145	01:17	3	00:12

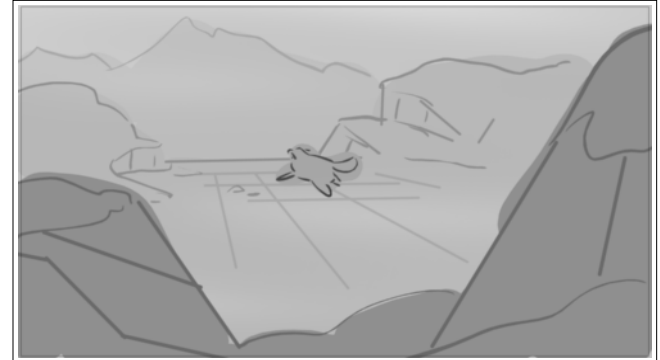

**Dialogue**  
 95. BELLE  
 (les appelle) Wouf. Wou wou wou wou.  
 Wouf !



Scene	Duration	Panel	Duration
147	01:17	1	00:12

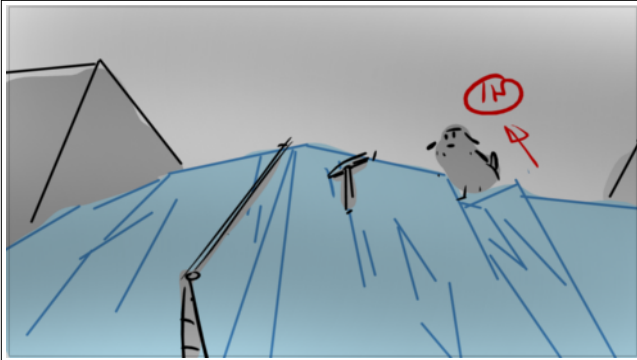

**Dialogue**

95. BELLE  
 (les appelle) Wouf. Wou wou wou wou.  
 Wouf !

Scene	Duration	Panel	Duration
147	01:17	2	01:05

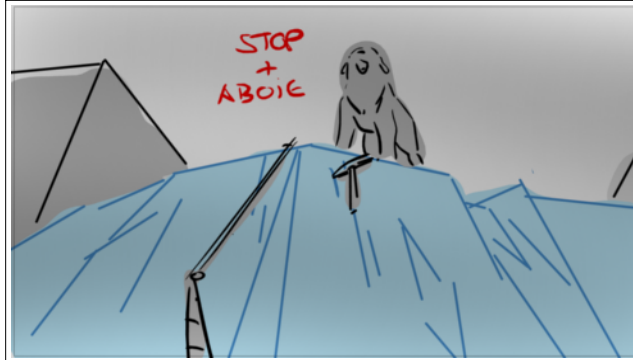

**Dialogue**

95. BELLE  
 (les appelle) Wouf. Wou wou wou wou.  
 Wouf !

Scene	Duration	Panel	Duration
148	02:09	1	02:09

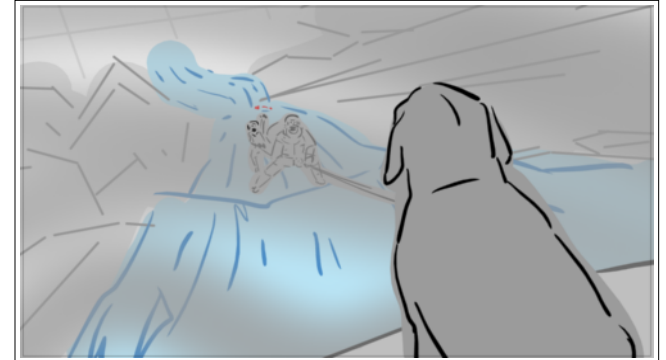

**Dialogue**

96. ANGELINA  
 BOUGEZ PAS !! ON ARRIVE !!

**Action Notes**

Angelina agite le bras en contrebass de Belle

Scene	Duration	Panel	Duration
149	01:21	1	00:13

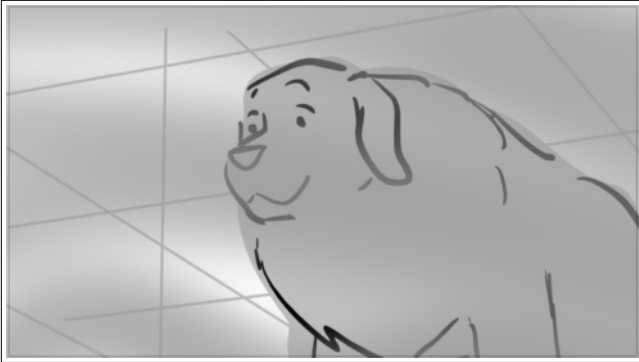

Scene	Duration	Panel	Duration
149	01:21	2	00:08



**Dialogue**

BELLE  
Wouf !

Scene	Duration	Panel	Duration
149	01:21	3	01:00

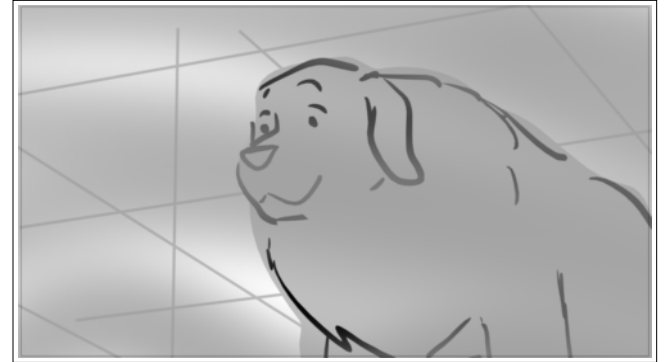

Dissolve	Duration 00:12
----------	-------------------

Scene 150	Duration 02:24	Panel 1	Duration 02:24
--------------	-------------------	------------	-------------------

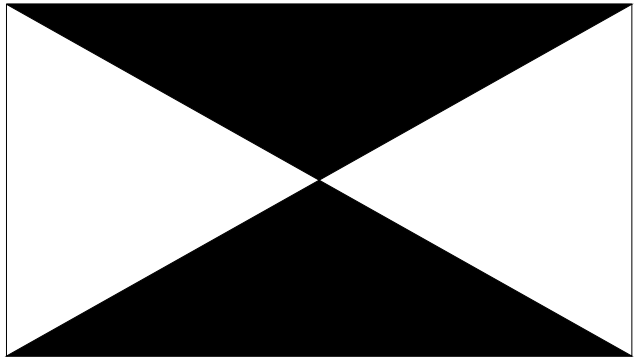
**Dialogue**

97. ANGELINA  
Merci ma Belle.

**Action Notes**

20. EXT - PIC SANS NOM, TRES HAUTE ALTITUDE - JOUR

SLOW PAN

César et Angelina ont rejoint Belle et Sébastien. César aide Sébastien à récupérer en lui donnant à boire

Scene	Duration	Panel	Duration
151	02:07	1	00:17



**Dialogue**  
 97. ANGELINA  
 Tu nous as parfaitement guidés jusqu'à vous !

Scene	Duration	Panel	Duration
151	02:07	2	00:15



**Dialogue**  
 97. ANGELINA  
 Tu nous as parfaitement guidés jusqu'à vous !

**Action Notes**  
 A lance un gâteau à BELLE

Scene	Duration	Panel	Duration
151	02:07	3	01:00



**Dialogue**  
 PU BELLE  
 Crunch! Crunch!

Scene	Duration	Panel	Duration
152	05:22	1	01:00

**Dialogue**

98. CÉSAR

Nous avons balisé tout le chemin,

Scene	Duration	Panel	Duration
152	05:22	2	01:00

**Dialogue**

98. CÉSAR

Nous avons balisé tout le chemin,

Scene	Duration	Panel	Duration
152	05:22	3	00:11

**Dialogue**

98. CÉSAR

Nous avons balisé tout le chemin,

Scene	Duration	Panel	Duration
152	05:22	4	00:06

**Dialogue**

98. CÉSAR

Nous pourrons redescendre en toute sécurité dès que tu iras mieux.

Scene	Duration	Panel	Duration
152	05:22	5	00:19

**Dialogue**

98. CÉSAR

Nous pourrons redescendre en toute sécurité dès que tu iras mieux.

**Action Notes**

SEb crache de surprise

Scene	Duration	Panel	Duration
152	05:22	6	00:12

**Dialogue**

98. CÉSAR

Nous pourrons redescendre en toute sécurité dès que tu iras mieux.

Scene	Duration	Panel	Duration
152	05:22	7	00:18



**Dialogue**

98. CÉSAR  
 Nous pourrons redescendre en toute  
 sécurité dès que tu iras mieux.

Scene	Duration	Panel	Duration
152	05:22	8	01:06



**Dialogue**

99. SÉBASTIEN  
 (tête de mule) On va pas redescendre  
 maintenant ?

Scene	Duration	Panel	Duration
154	04:11	1	00:09



Scene	Duration	Panel	Duration
154	04:11	2	00:12



**Dialogue**

99. SÉBASTIEN (tête de mule)  
On est si près du but !

**Action Notes**

César range la gourde dans le sac OS

Scene	Duration	Panel	Duration
154	04:11	3	01:01



**Dialogue**

99. SÉBASTIEN (tête de mule)  
On est si près du but !

**Action Notes**

la couverture tombe des épaules de SEB

Scene	Duration	Panel	Duration
154	04:11	4	02:14



**Dialogue**

104. CÉSAR  
C'est à ça qu'on reconnaît les grands alpinistes mon garçon!.



Scene	Duration	Panel	Duration
155	04:22	1	00:14



**Dialogue**  
 104. CÉSAR  
 Ils savent renoncer quand la montagne est plus forte.

Scene	Duration	Panel	Duration
155	04:22	2	01:21



**Dialogue**  
 104. CÉSAR  
 Ils savent renoncer quand la montagne est plus forte.

**Action Notes**  
 SEb vascille de vertige

Scene	Duration	Panel	Duration
155	04:22	3	01:12



**Dialogue**  
 104. CÉSAR  
 Ils savent renoncer quand la montagne est plus forte.

**Action Notes**  
 S regarde en l'air

Scene	Duration	Panel	Duration
155	04:22	4	01:00



**Dialogue**  
 101. SÉBASTIEN (insiste)  
 Mais regardez!!

Scene	Duration	Panel	Duration
156	02:00	1	02:00

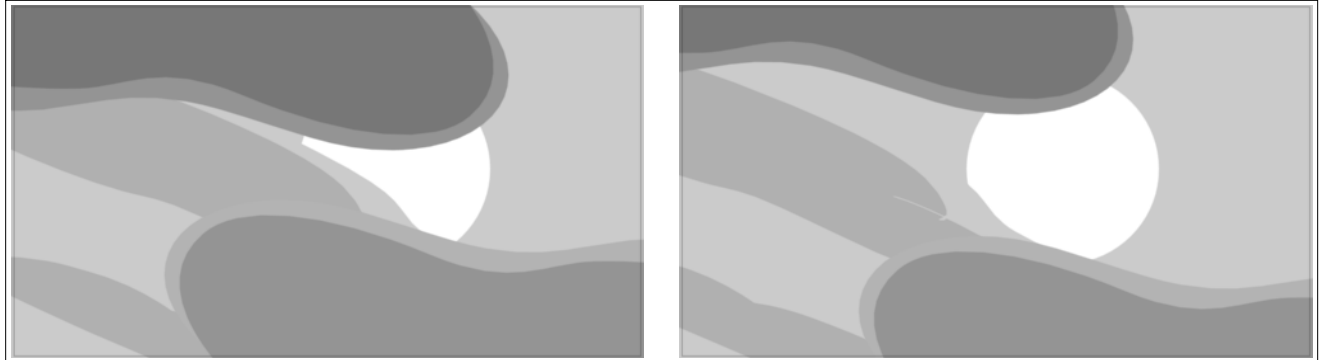

**Dialogue**  
 101. SÉBASTIEN (insiste)  
 la brume se lève !!

**Action Notes**  
 Le soleil réapparaît

**Notes**  
 FX SUN  
 FX CLOUDS

Scene	Duration	Panel	Duration
157	06:04	1	01:04

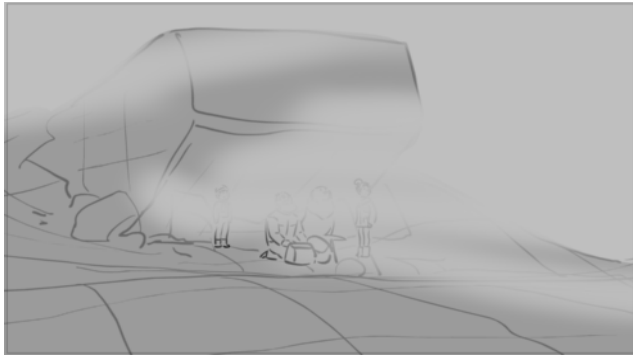
**Dialogue**

101. SÉBASTIEN MODIF

Jean-Baptiste avait raison : c'est possible d'y arriver le jour du solstice d'ètè !

**Action Notes**

La brume se disspe

Scene	Duration	Panel	Duration
157	06:04	2	00:06

**Dialogue**

101. SÉBASTIEN MODIF

Jean-Baptiste avait raison : c'est possible d'y arriver le jour du solstice d'ètè !

Scene	Duration	Panel	Duration
157	06:04	3	00:10



**Dialogue**

101. SÉBASTIEN MODIF

Jean-Baptiste avait raison : c'est possible d'y arriver le jour du solstice d'été !

**Action Notes**

le soleil revient  
FX light

Scene	Duration	Panel	Duration
157	06:04	4	00:16



**Dialogue**

101. SÉBASTIEN MODIF

Jean-Baptiste avait raison : c'est possible d'y arriver le jour du solstice d'été !

**Action Notes**

SEb s'avance en titubant

Scene	Duration	Panel	Duration
157	06:04	5	01:09



**Dialogue**

101. SÉBASTIEN MODIF

Jean-Baptiste avait raison : c'est possible d'y arriver le jour du solstice d'été !

Scene	Duration	Panel	Duration
157	06:04	6	01:04



**Dialogue**

101. SÉBASTIEN MODIF

Jean-Baptiste avait raison : c'est possible d'y arriver le jour du solstice d'été !

**Action Notes**

s'écroule saisit de vertige

Scene	Duration	Panel	Duration
157	06:04	7	01:05



**Dialogue**

101. SÉBASTIEN MODIF

Jean-Baptiste avait raison : c'est possible d'y arriver le jour du solstice d'été !

Scene	Duration	Panel	Duration
158	07:05	1	00:06

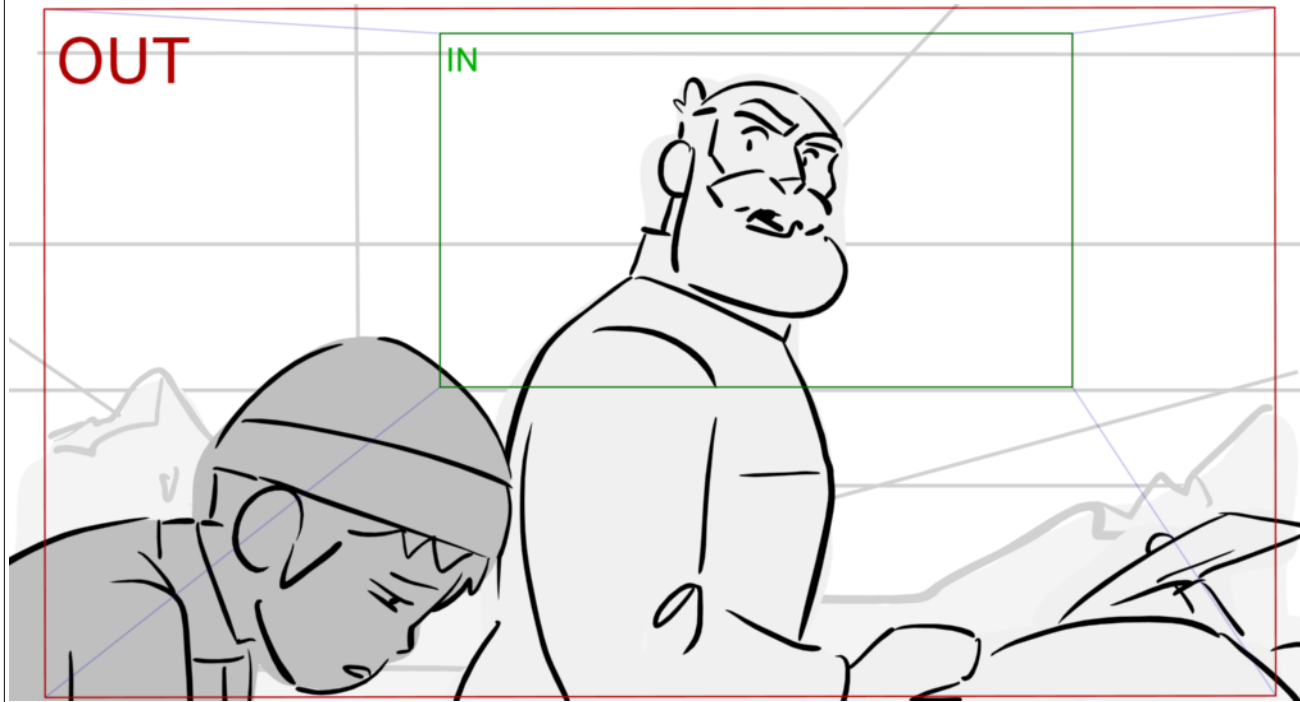

Scene	Duration	Panel	Duration
158	07:05	2	03:03

**Dialogue**

100. CÉSAR (ferme)

On ne plaisante pas avec le mal des montagnes Sébastien !

**Action Notes**

TRK OUT

NO PANEL

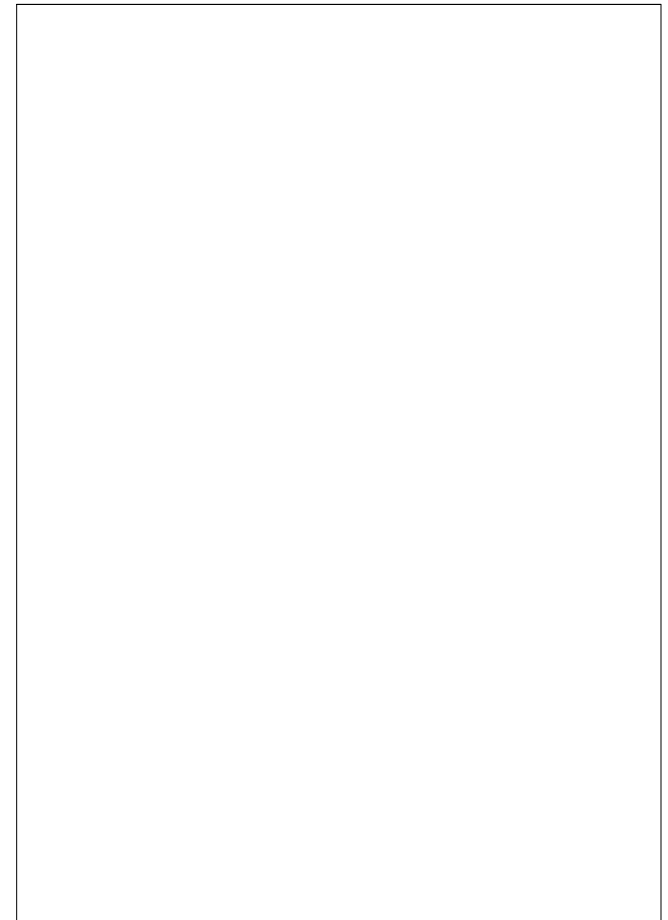
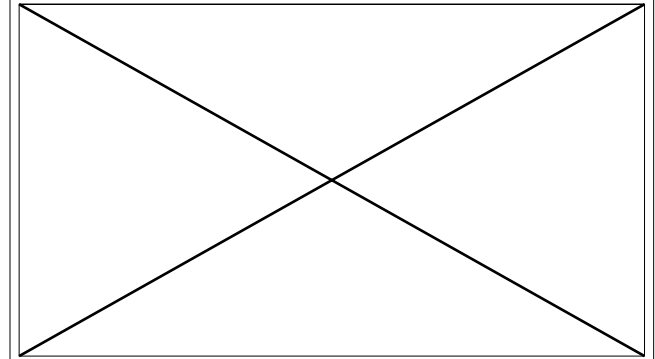

Scene	Duration	Panel	Duration
158	07:05	3	01:01



NO PANEL

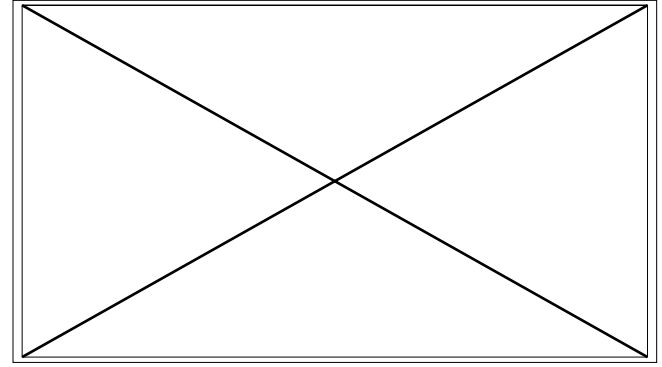

**Dialogue**

100. CÉSAR (ferme)

On ne plaisante pas avec le mal des montagnes Sébastien !

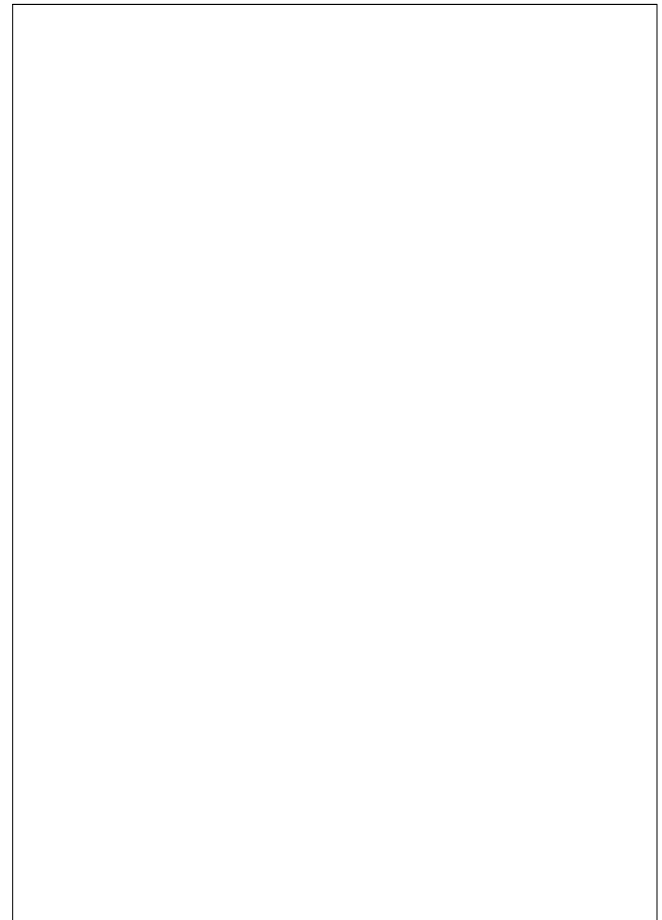

Scene	Duration	Panel	Duration
158	07:05	4	02:20



**Dialogue**

100. CÉSAR (ferme)  
On ne plaisante pas avec le mal des montagnes Sébastien !

Scene	Duration	Panel	Duration
160	04:07	1	04:07

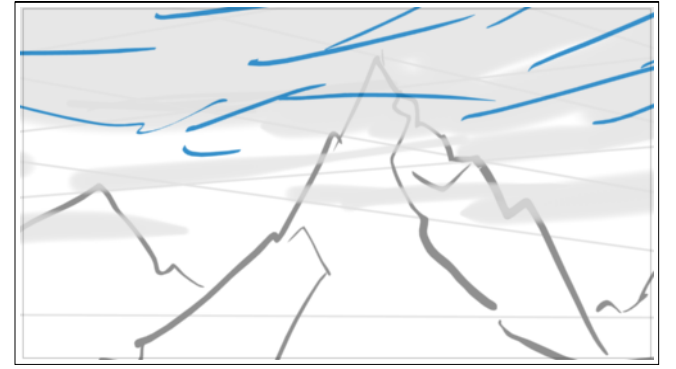

**Dialogue**

100. CÉSAR (ferme)  
J'en suis déjà redescendu une fois sans mon coéquipier... C'était une fois de trop.

**Action Notes**

POV SEB= ESTAB sommet  
La brume remonte vers le sommet



Scene	Duration	Panel	Duration
160_A	01:20	1	00:23



**Dialogue**  
 102. ANGELINA  
 Sébastien...sois raisonnable.

Scene	Duration	Panel	Duration
160_A	01:20	2	00:22



**Dialogue**  
 102. ANGELINA  
 Sébastien...sois raisonnable.

Scene	Duration	Panel	Duration
161	05:08	1	01:05



**Action Notes**  
 SEB boude

Scene	Duration	Panel	Duration
161	05:08	2	01:05



Scene	Duration	Panel	Duration
161	05:08	3	01:05



**Action Notes**

FAST TRK OUT  
SEB a une idée

Scene	Duration	Panel	Duration
161	05:08	4	00:18



Scene	Duration	Panel	Duration
161	05:08	5	01:00



**Dialogue**  
 108. SÉBASTIEN  
 Regardez là-bas...

Scene	Duration	Panel	Duration
162	04:20	1	00:06





Scene	Duration	Panel	Duration
162	04:20	2	00:16

Scene	Duration	Panel	Duration
162	04:20	3	00:20

Scene	Duration	Panel	Duration
162	04:20	4	00:18

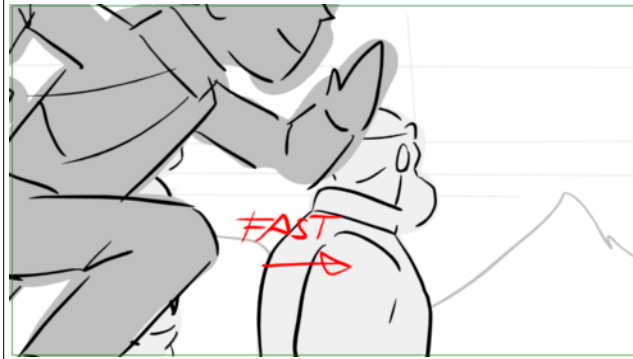
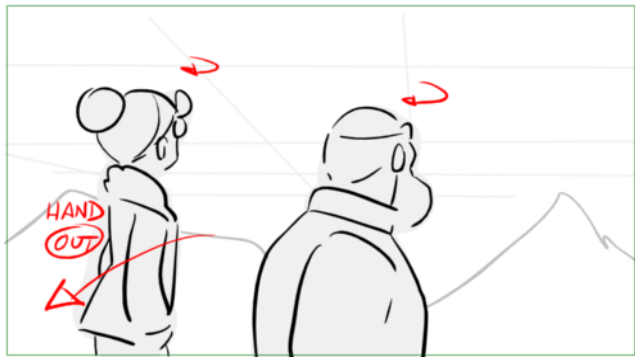

**Action Notes**

SEb fast IN OUT

Scene	Duration	Panel	Duration
162	04:20	5	00:18

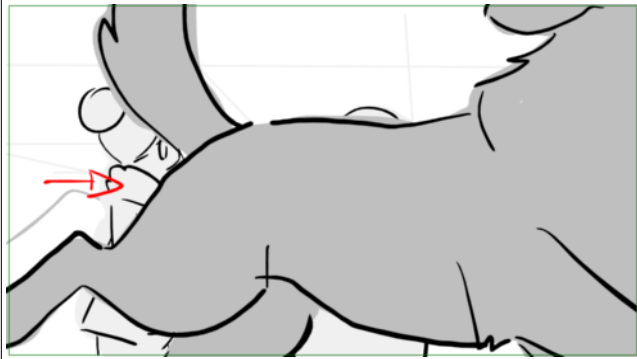

**Dialogue**

105. BELLE  
Wouf !

**Action Notes**

BELLE le suit

Scene	Duration	Panel	Duration
162	04:20	6	00:12



**Dialogue**

106. CÉSAR  
Mais c'est pas vrai ça.

NO PANEL

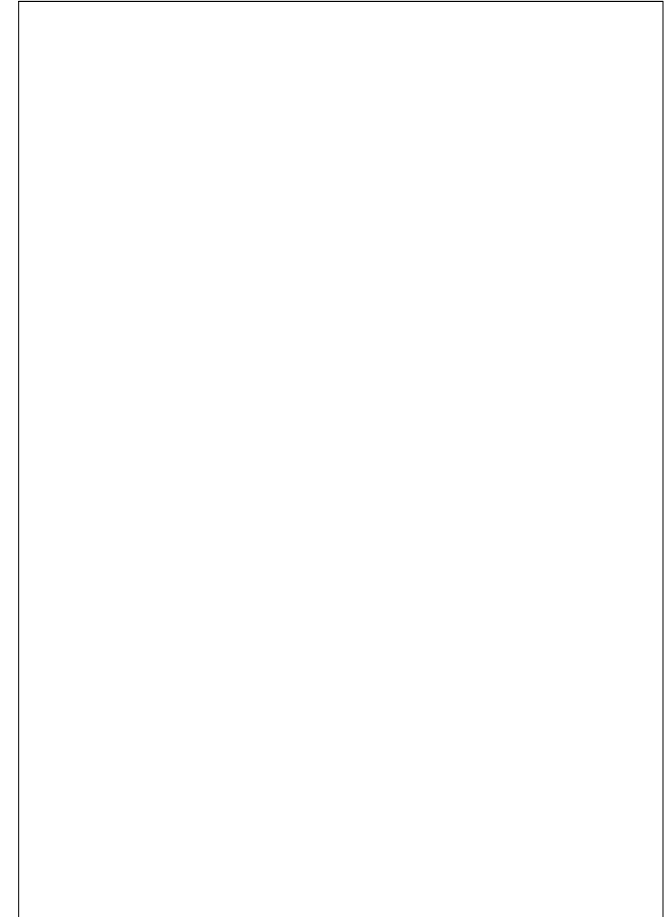
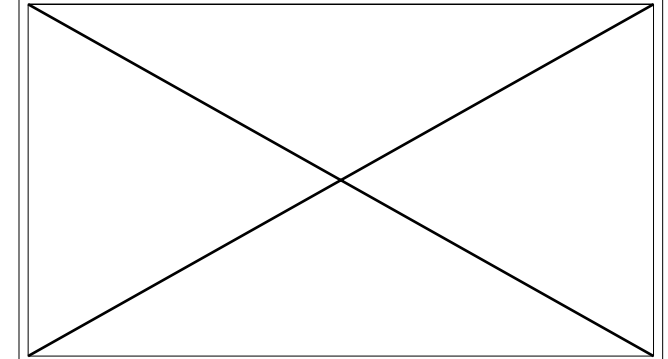

Scene	Duration	Panel	Duration
162	04:20	7	01:05

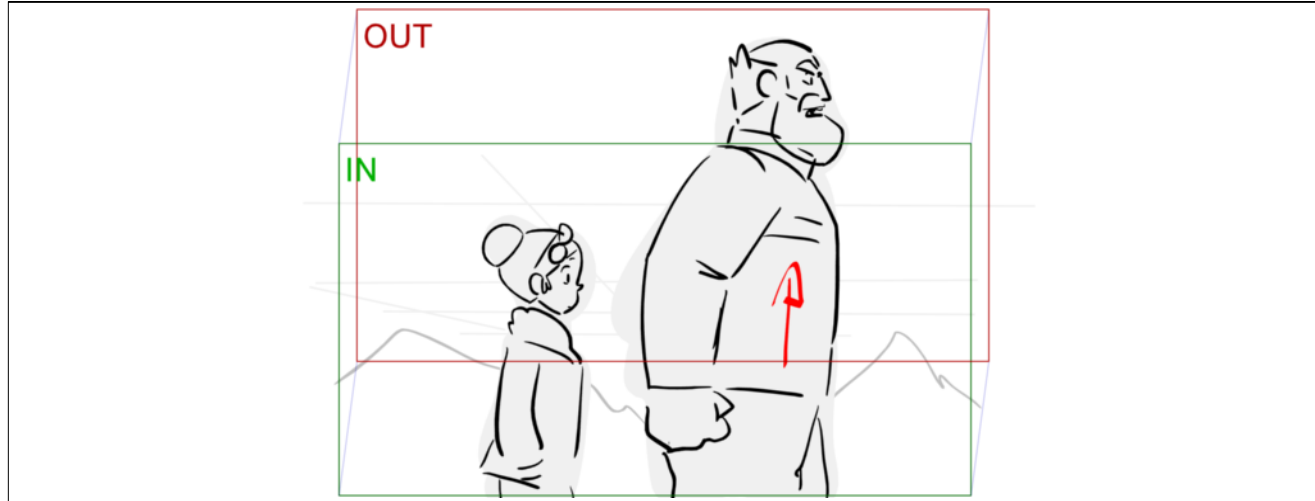

**Dialogue**  
 106. CÉSAR  
 Mais c'est pas vrai ça.

**Action Notes**  
 César se lève estomaqué  
 PAN FOLLOW

Scene	Duration	Panel	Duration
163	02:18	1	01:00

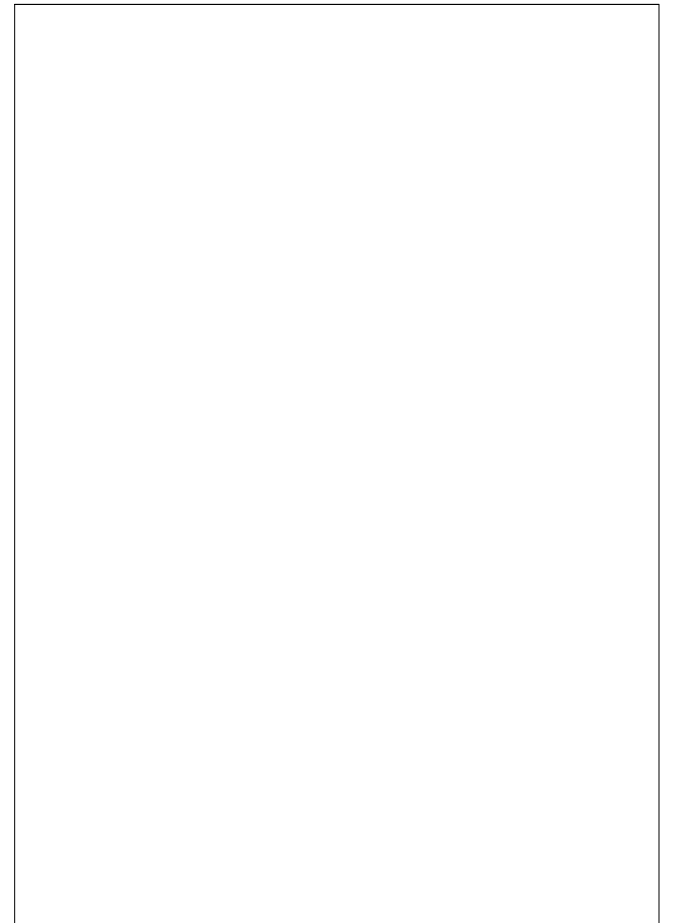

Scene	Duration	Panel	Duration
163	02:18	2	01:00

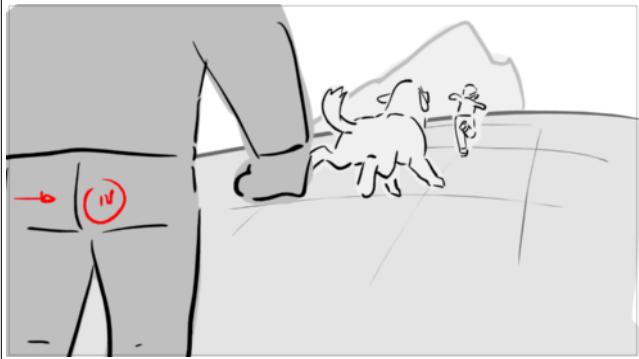

**Dialogue**  
 106. CÉSAR  
 Sébastien ! Reviens ici !

**Action Notes**  
 SEb et BELLE se précipitent vers la crête

Scene	Duration	Panel	Duration
163	02:18	3	00:18

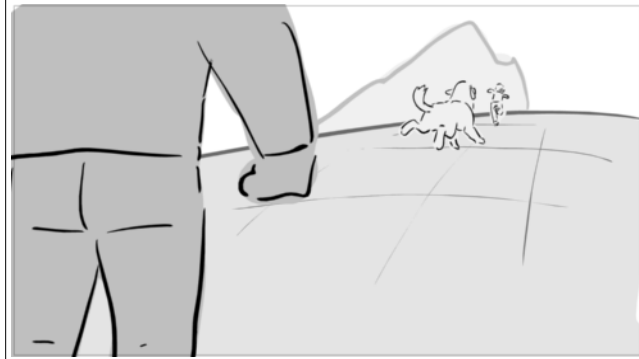

**Dialogue**  
 106. CÉSAR  
 Sébastien ! Reviens ici !

Scene	Duration	Panel	Duration
164	02:22	1	00:17



**Dialogue**  
 109. CÉSAR  
 Quelle tête de mule !...

Scene	Duration	Panel	Duration
164	02:22	2	01:17

**Dialogue**

109. CÉSAR  
Quelle tête de mule !...

Scene	Duration	Panel	Duration
164	02:22	3	00:13

**Dialogue**

107. SÉBASTIEN (OFF)  
Venez.

Scene	Duration	Panel	Duration
165	04:01	1	01:09

**Dialogue**

107. SÉBASTIEN  
Faut que vous voyiez ça !

**Action Notes**

SEb agite le bras



Scene	Duration	Panel	Duration
165	04:01	2	00:21

**Dialogue**

107. SÉBASTIEN

Faut que vous voyiez ça !

Scene	Duration	Panel	Duration
165	04:01	3	00:16

**Dialogue**

107. SÉBASTIEN

Faut que vous voyiez ça !

Scene	Duration	Panel	Duration
165	04:01	4	01:05

**Dialogue**

107. SÉBASTIEN

Faut que vous voyiez ça !

Scene	Duration	Panel	Duration
166	04:01	1	00:06



Scene	Duration	Panel	Duration
166	04:01	2	00:15



**Dialogue**  
 108. SÉBASTIEN  
 Il avait réussi.

NO PANEL

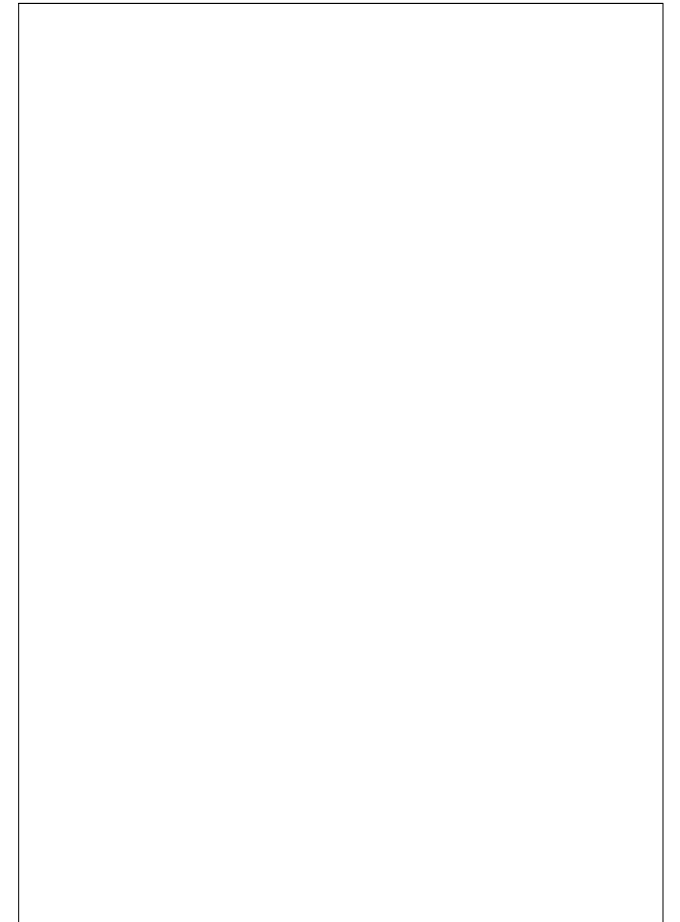
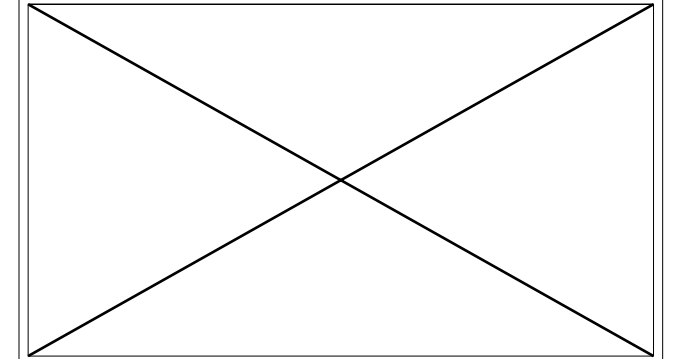

Scene	Duration	Panel	Duration
166	04:01	3	01:13

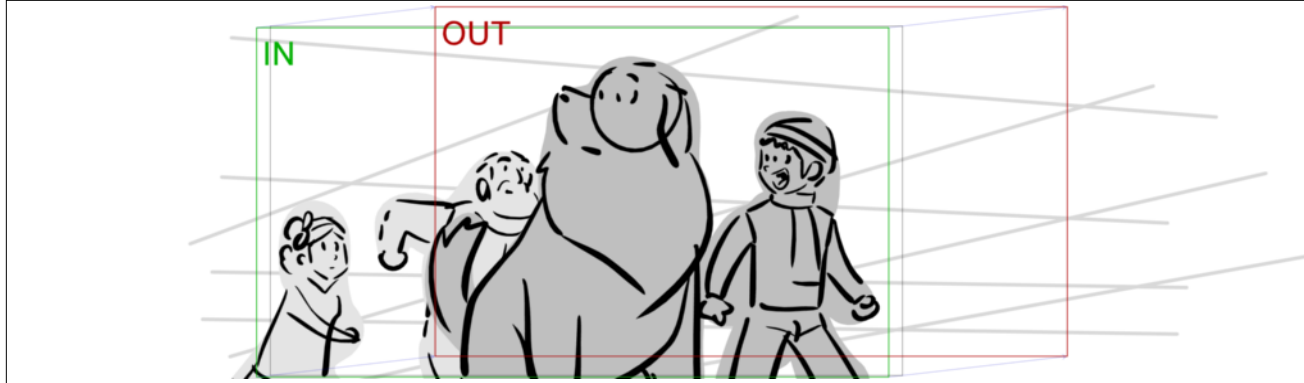
**Dialogue**

108. SÉBASTIEN  
Regardez là-bas...

NO PANEL

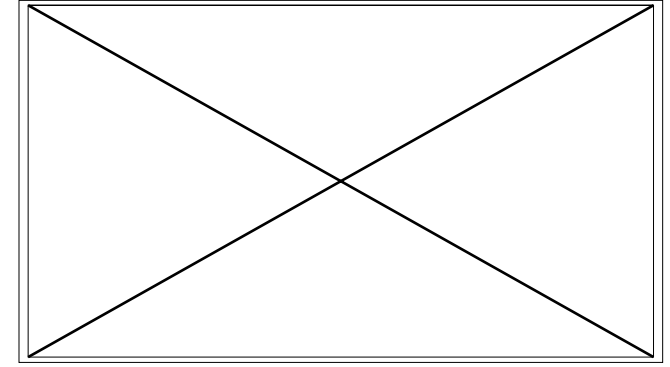

Scene	Duration	Panel	Duration
166	04:01	4	01:17

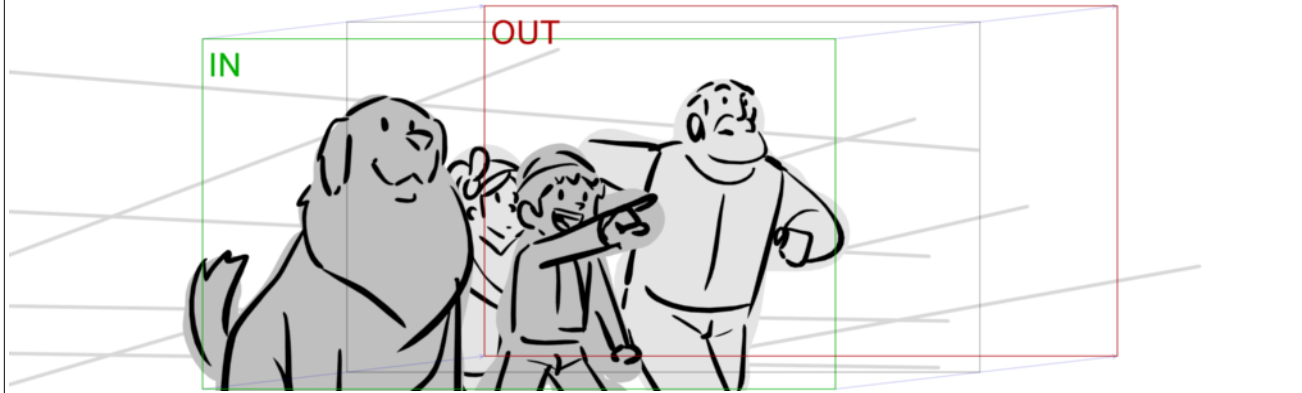
**Dialogue**

108. SÉBASTIEN

Il avait réussi. Nino avait réussi !

Scene	Duration	Panel	Duration
167	02:10	1	00:05

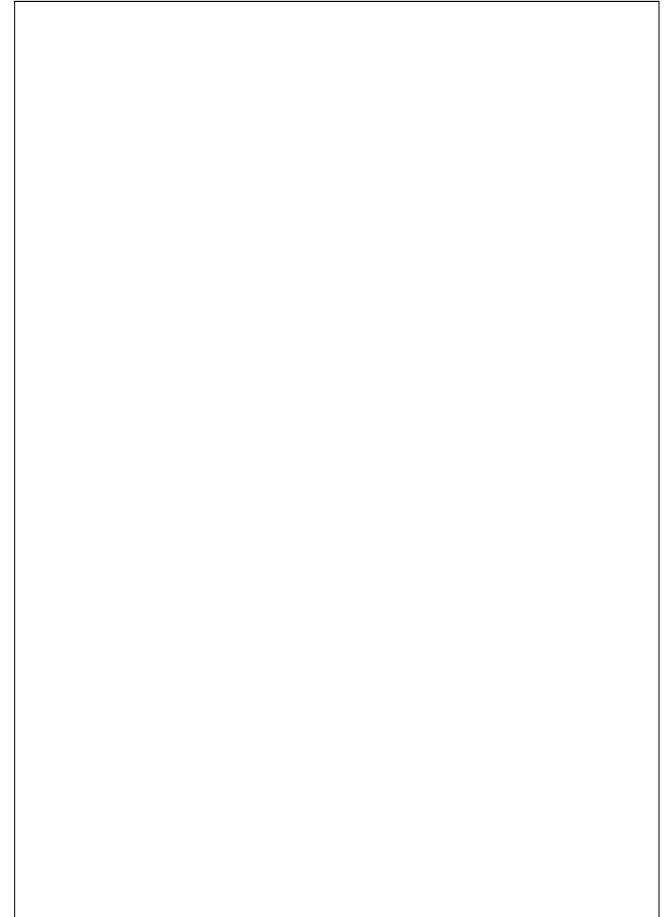
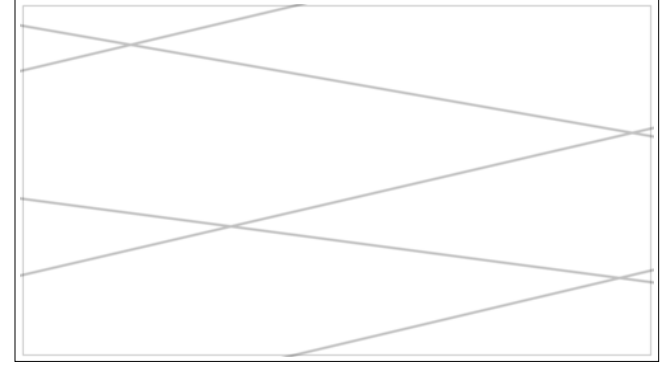

Scene	Duration	Panel	Duration
167	02:10	2	00:11

Scene	Duration	Panel	Duration
167	02:10	3	01:19

NO PANEL

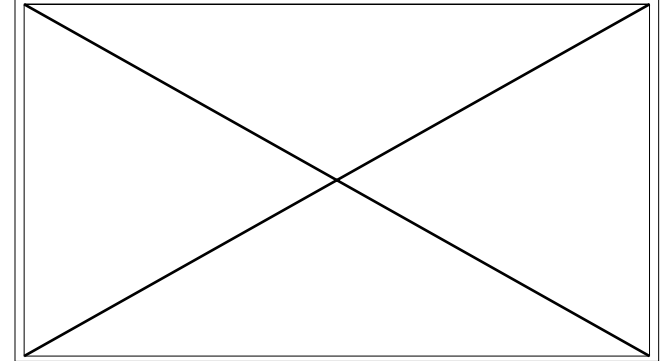

**Dialogue**  
PU CESAR  
Oh! ça alors!

Scene	Duration	Panel	Duration
168	03:12	1	03:12

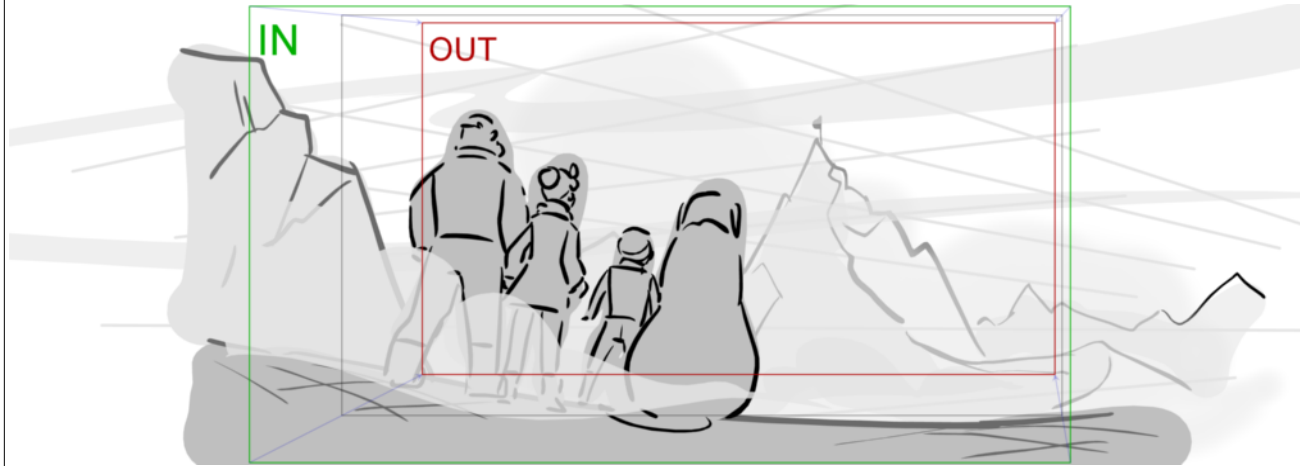
**Dialogue**

PU CESAR  
C'est le drapeau de Nino là bas!

**Action Notes**

TRK IN PIC sans nom  
La brume se lève laissant apparaitre un drapeau  
FX BRUME VENT et POUSSIERE DE NEIGE

NO PANEL

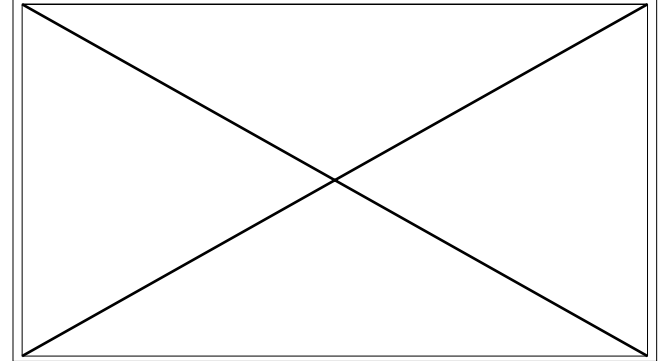



Scene	Duration	Panel	Duration
169	04:01	1	04:01

NO PANEL

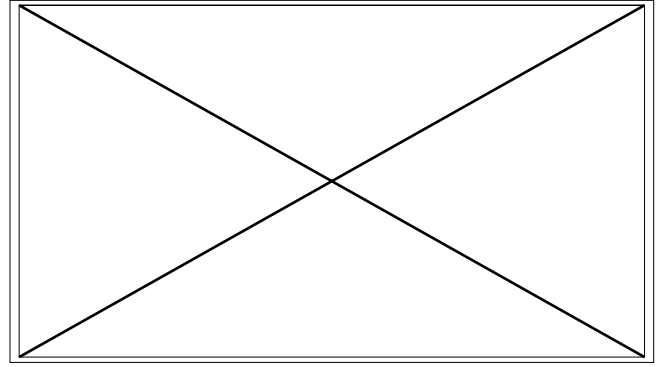
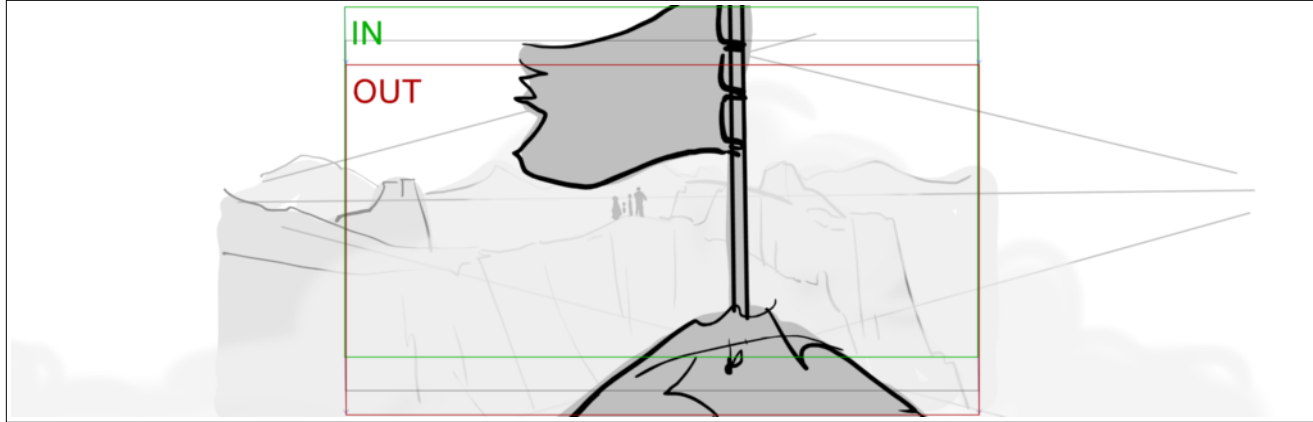

**Dialogue**  
PU ANGELINA  
Il aura réussi à atteindre le sommet finalement!

**Action Notes**  
CLOSE UP sur le drapeau  
PAN DOWN  
Drapeau SLIDES laissant apparaître nos héros sur la crête opposée  
FX Brume et Vent

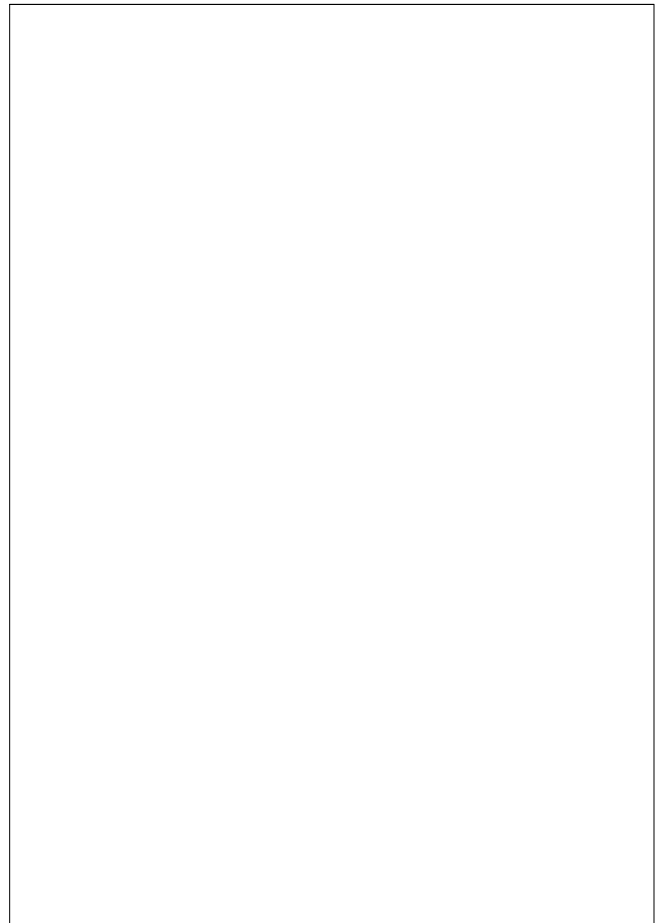

Scene	Duration	Panel	Duration
170	02:23	1	02:23



**Dialogue**  
 PU CESAR  
 Il a réalisé son rêve avant de disparaître!

**Action Notes**  
 Slow PAN

Scene	Duration	Panel	Duration
171	03:15	1	00:22



**Action Notes**  
 Les yeux d'Angelina sont humides



Scene	Duration	Panel	Duration
171	03:15	2	01:17

Scene	Duration	Panel	Duration
171	03:15	3	01:01

Scene	Duration	Panel	Duration
172	02:19	1	00:11

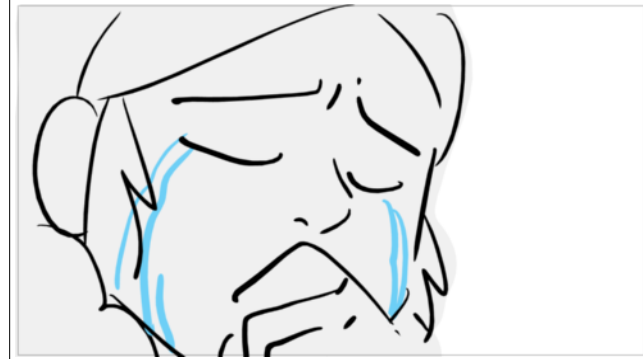
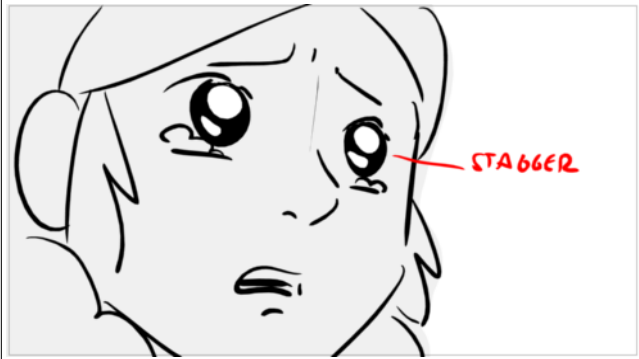

**Dialogue**

110. ANGELINA  
Et dire que depuis tout ce temps,  
personne ne le savait...

**Action Notes**

FX plaus

Scene	Duration	Panel	Duration
172	02:19	2	00:19



**Action Notes**

Belle et SEb se ragerdent tristes

Scene	Duration	Panel	Duration
172	02:19	3	00:15



**Action Notes**

Seb sort la photo de sa poche

Scene	Duration	Panel	Duration
172	02:19	4	00:24



Scene	Duration	Panel	Duration
173	03:15	1	00:16

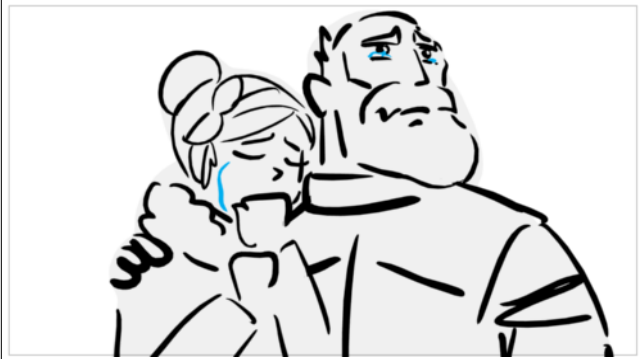

Scene	Duration	Panel	Duration
173	03:15	2	00:17

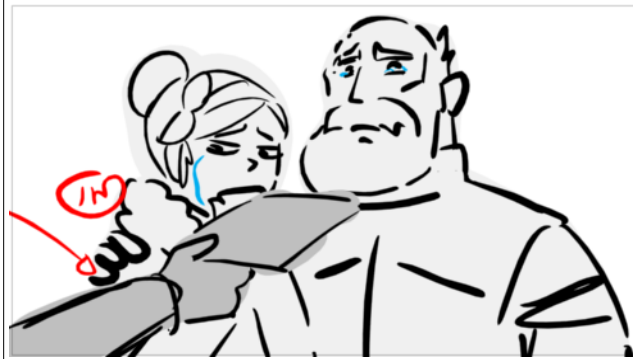

**Dialogue**  
 111. SÉBASTIEN  
 Tenez...

Scene	Duration	Panel	Duration
173	03:15	3	02:07



**Dialogue**  
 111. SÉBASTIEN  
 j'avais pensé que ce serait bien de la  
 déposer sur le Pic...

Scene	Duration	Panel	Duration
174	02:14	1	00:14



Scene	Duration	Panel	Duration
174	02:14	2	01:00

**Dialogue**

112. SEBASTIEN  
(taquin) Et puis, vu le look que tu  
avais à l'époque,

Scene	Duration	Panel	Duration
174	02:14	3	01:00

**Dialogue**

112. SEBASTIEN  
j'pense qu'il vaut mieux se débarrasser  
de cette photo. (rigolard)



Scene	Duration	Panel	Duration
175	02:14	1	00:13



Scene	Duration	Panel	Duration
175	02:14	2	01:16



Scene	Duration	Panel	Duration
175	02:14	3	00:10

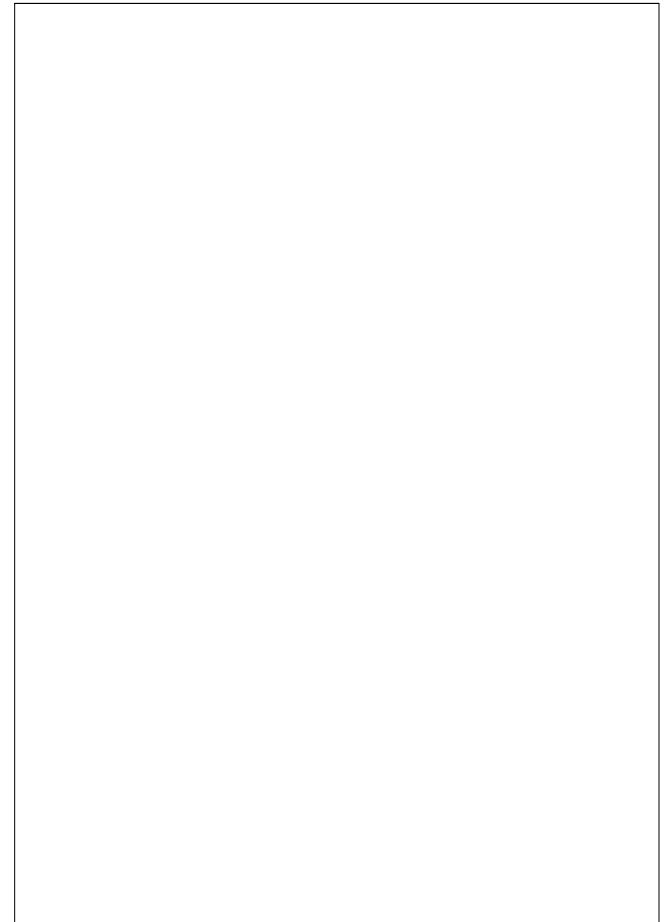
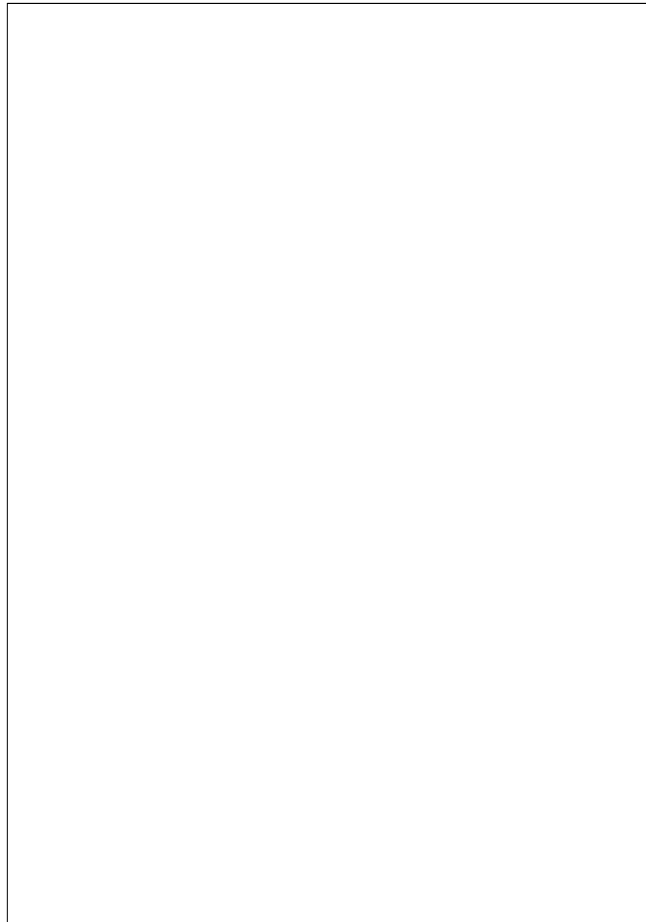
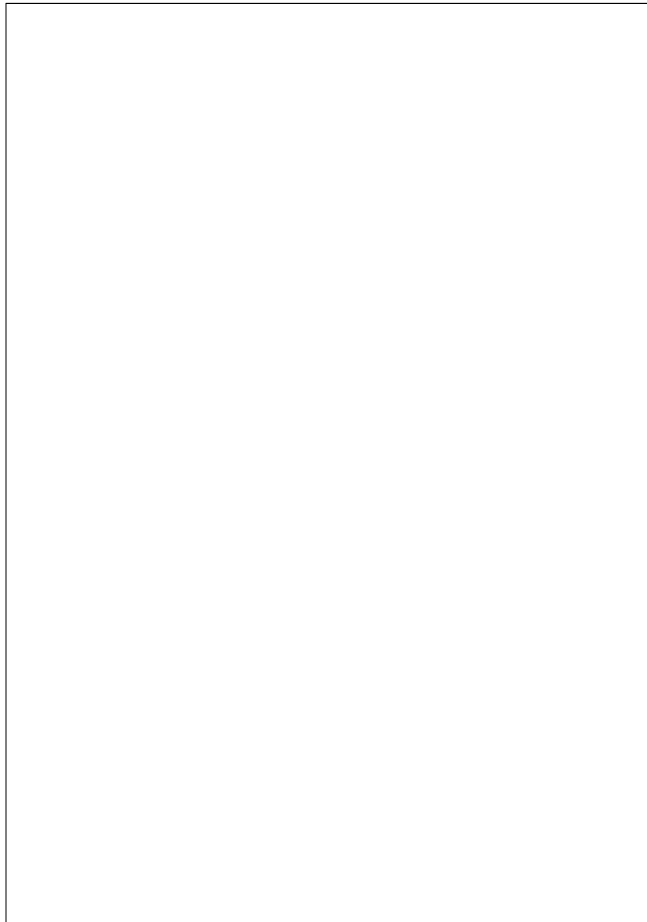

Scene	Duration	Panel	Duration
176	04:07	1	02:01



**Dialogue**  
 112. SEBASTIEN  
 (rigolard) Nan mais c'est vrai, t'as vu ton bonnet ?

**Action Notes**  
 SEB rigole

Scene	Duration	Panel	Duration
176	04:07	2	02:06



**Dialogue**  
 RIRES

**Action Notes**  
 tout le monde rigole

Scene	Duration	Panel	Duration
177	02:01	1	00:11

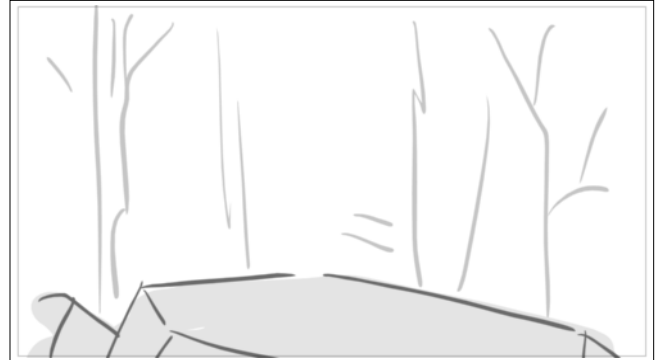

**Action Notes**  
 21. EXT - PIC SANS NOM, VUE SUR LE SOMMET - JOUR

Scene	Duration	Panel	Duration
177	02:01	2	00:21

Scene	Duration	Panel	Duration
177	02:01	3	00:12

Scene	Duration	Panel	Duration
177	02:01	4	00:07



**Action Notes**

Main d'Angelina IN glisse la photo dans la fente d'un rocher

Scene	Duration	Panel	Duration
178	01:12	1	00:10



Scene	Duration	Panel	Duration
178	01:12	2	01:02



Scene	Duration	Panel	Duration
179	02:01	1	01:10



**Action Notes**

POV SEB à travers objectif d'un  
 appareil photo  
 C, A, et B recueillis devant la photo



Scene	Duration	Panel	Duration
179	02:01	2	00:16

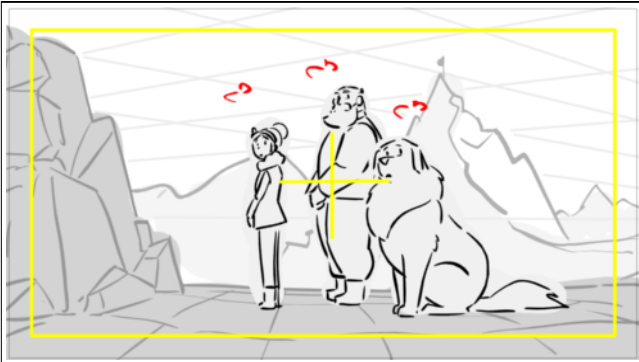

**Dialogue**

113. SÉBASTIEN  
Vous êtes prêts ?

**Action Notes**

les trois se tournent vers l'objectif

Scene	Duration	Panel	Duration
180	01:20	1	00:10



**Action Notes**

SEB finit son réglage

Scene	Duration	Panel	Duration
180	01:20	2	01:10



**Dialogue**

113. SÉBASTIEN  
On va en faire une mieux.

**Action Notes**

et se relève

Scene	Duration	Panel	Duration
181	01:08	1	00:12

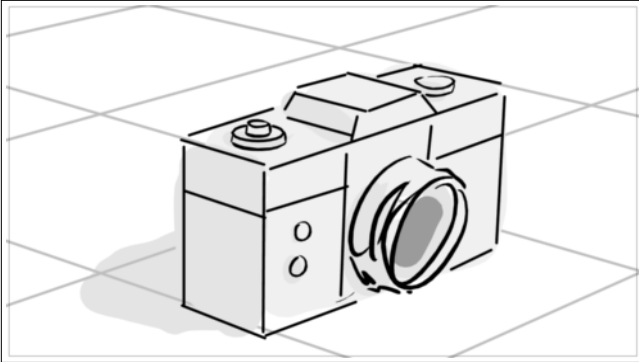

Scene	Duration	Panel	Duration
181	01:08	2	00:21

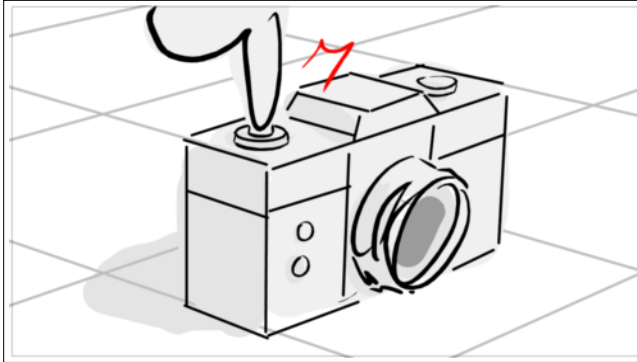

**Action Notes**  
doigt de seb appuie sur le retardateur

Scene	Duration	Panel	Duration
182	02:07	1	00:13



**Dialogue**  
SFX PHOTO

**Action Notes**  
POV objectif

Scene	Duration	Panel	Duration
182	02:07	2	00:18

Scene	Duration	Panel	Duration
182	02:07	3	00:20

Scene	Duration	Panel	Duration
182	02:07	4	00:06

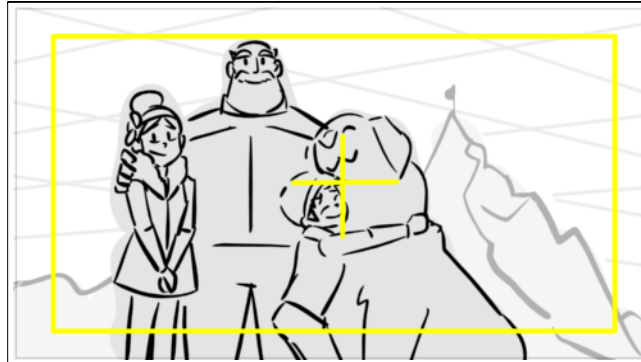

**Dialogue**  
SFX PHOTO

**Dialogue**  
SFX PHOTO

**Dialogue**  
SFX PHOTO

**Action Notes**  
SEb zip IN

**Action Notes**  
FX FLASH

Scene	Duration	Panel	Duration
183	04:05	1	01:04

**Dialogue**

116. GABRIEL  
Ouah,

**Action Notes**

23. INT - ECOLE, SALLE DE CLASSE - JOUR  
POV GABRIEL

Scene	Duration	Panel	Duration
183	04:05	2	00:16

**Dialogue**

116. GABRIEL  
c'est toi sur la photo ?

**Action Notes**

TRK OUT

Scene	Duration	Panel	Duration
183	04:05	3	00:16

**Dialogue**

116. GABRIEL

c'est toi sur la photo ?

**Action Notes**

Photo OUT révélant SEB au tableau avec la baguette  
Il a accroché une photo de Nino et une grande photo du Pic Sans Nom.

Scene	Duration	Panel	Duration
183	04:05	4	00:07

**Action Notes**

Photo OUT révélant SEB au tableau avec la baguette  
Il a accroché une photo de Nino et une grande photo du Pic Sans Nom.

Scene	Duration	Panel	Duration
183	04:05	5	00:08

Scene	Duration	Panel	Duration
183	04:05	6	00:08

Scene	Duration	Panel	Duration
183	04:05	7	00:21



**Dialogue**  
 PU SEBASTIEN  
 Hmmm Hmmm

**Dialogue**  
 PU SEBASTIEN  
 Hmmm Hmmm

**Action Notes**  
 SEB opine

Scene	Duration	Panel	Duration
184	04:03	1	03:03



**Dialogue**

117. LES ÉLÈVES DE LA CLASSE (réaction collective, impressionnés) Waou... / Trop classe / La chance... / C'est incroyable...

**Action Notes**

Les élèves sont agglutinés autour de Gabriel et de la photo

Scene	Duration	Panel	Duration
184	04:03	2	01:00



**Dialogue**

115. SÉBASTIEN

Et c'est en voyant son drapeau au sommet

**Action Notes**

Tous lèvent les yeux vers SEB

Scene	Duration	Panel	Duration
185	04:04	1	02:20



NO PANEL

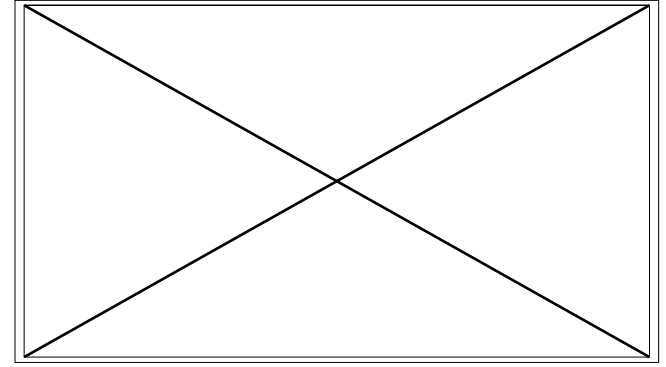

#### Dialogue

115. SÉBASTIEN

qu'on a découvert, après toutes ces années, que Nino avait réussi à gravir le Pic Sans Nom.

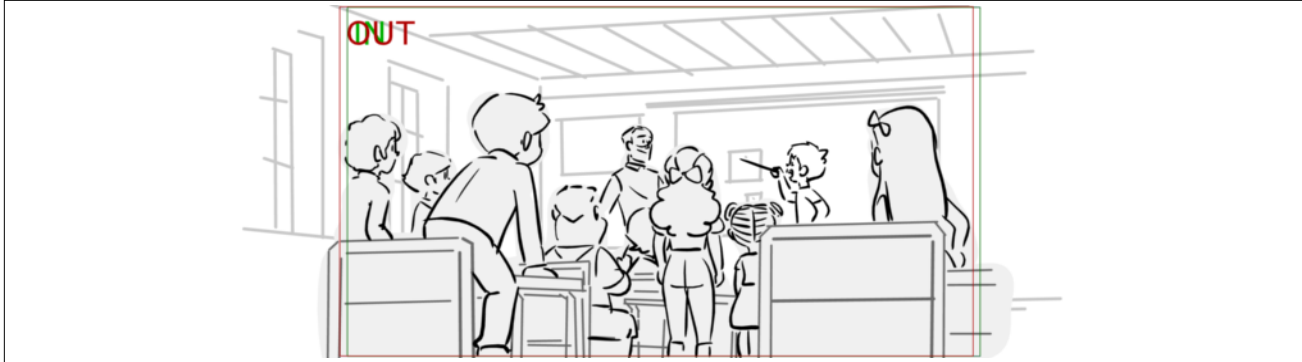

Scene	Duration	Panel	Duration
185	04:04	2	01:09

**Dialogue**

115. SÉBASTIEN

qu'on a découvert, après toutes ces années, que Nino avait réussi à gravir le Pic Sans Nom.

Scene	Duration	Panel	Duration
186	03:20	1	01:05

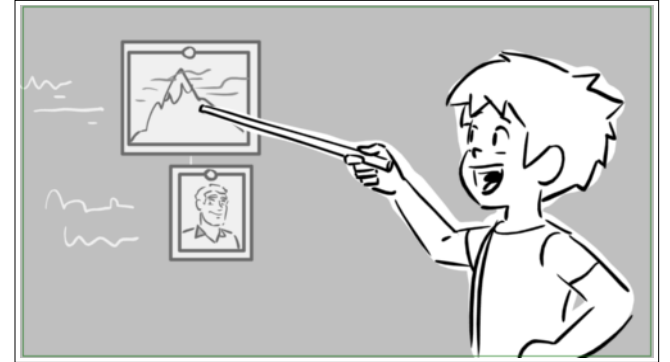
**Dialogue**

115. SÉBASTIEN

Qu'on peut désormais appeler le Pic de Nino !

Scene	Duration	Panel	Duration
186	03:20	2	01:09



**Dialogue**

115. SÉBASTIEN

Qu'on peut désormais appeler le Pic de Nino !

Scene	Duration	Panel	Duration
186	03:20	3	01:06



**Dialogue**

115. SÉBASTIEN

Qu'on peut désormais appeler le Pic de Nino !

Scene	Duration	Panel	Duration
187	04:21	1	01:00



**Dialogue**

118. JEAN-BAPTISTE

Merci Sébastien. Merci d'avoir partagé avec nous une partie de l'histoire de ta famille.

Scene	Duration	Panel	Duration
187	04:21	2	00:18



**Dialogue**

118. JEAN-BAPTISTE

Merci Sébastien. Merci d'avoir partagé avec nous une partie de l'histoire de ta famille.

**Action Notes**

SEb repose la baguette

Scene	Duration	Panel	Duration
187	04:21	3	01:04



**Dialogue**

118. JEAN-BAPTISTE

Merci Sébastien. Merci d'avoir partagé avec nous une partie de l'histoire de ta famille.

Scene	Duration	Panel	Duration
187	04:21	4	01:11



**Dialogue**

118. JEAN-BAPTISTE

Merci Sébastien. Merci d'avoir partagé avec nous une partie de l'histoire de ta famille.



Scene	Duration	Panel	Duration
187	04:21	5	00:13



Scene	Duration	Panel	Duration
188	04:07	1	00:02



Scene	Duration	Panel	Duration
188	04:07	2	01:05

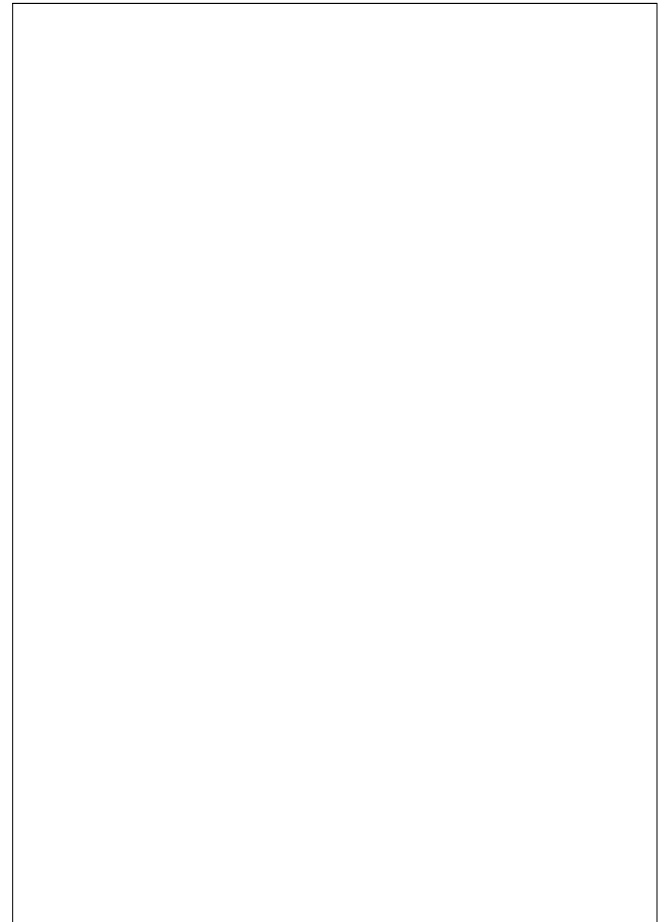
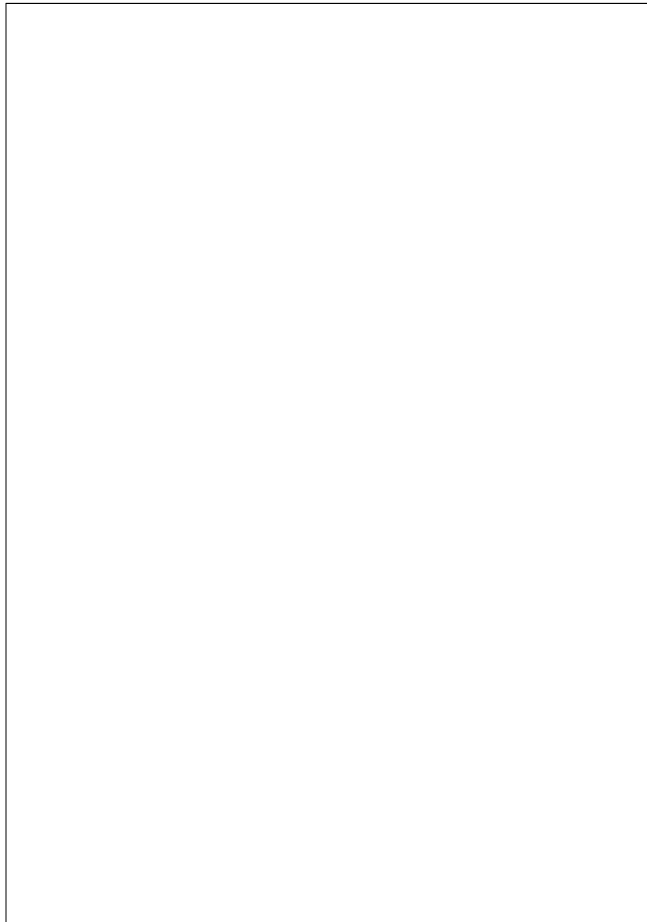

Scene	Duration	Panel	Duration
188	04:07	3	01:01



**Dialogue**  
 119. CAMÉO (cherche la petite bête, en regardant la photo)  
 c'est pas le sommet !

Scene	Duration	Panel	Duration
188	04:07	4	01:24



**Dialogue**  
 119. CAMÉO  
 Vous n'êtes pas montés jusqu'en haut en fait !

Scene	Duration	Panel	Duration
189	04:09	1	00:07



**Dialogue**  
 120. SÉBASTIEN  
 Nan. Mais Nino l'a fait lui.

Scene	Duration	Panel	Duration
189	04:09	2	01:02



**Dialogue**  
 120. SÉBASTIEN  
 Nan. Mais Nino l'a fait lui.

Scene	Duration	Panel	Duration
189	04:09	3	01:02



**Dialogue**  
 120. SÉBASTIEN  
 Nan. Mais Nino l'a fait lui.

Scene	Duration	Panel	Duration
189	04:09	4	01:23



**Dialogue**  
 120. SÉBASTIEN  
 Et comme il fait partie de ma famille...

Scene	Duration	Panel	Duration
190	05:23	1	01:14



**Dialogue**  
 PU SEBASTIEN  
 D'autres questions?

Scene	Duration	Panel	Duration
190	05:23	2	00:18



**Dialogue**  
 PU SEBASTIEN  
 D'autres questions?

Scene	Duration	Panel	Duration
190	05:23	3	02:06

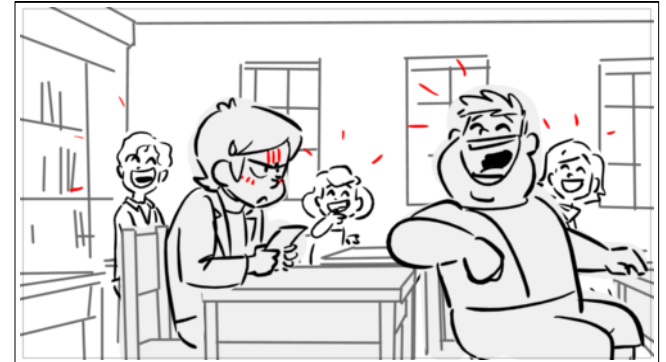

**Dialogue**  
 RIRES

Scene	Duration	Panel	Duration
190	05:23	4	01:10



**Dialogue**  
 PU GABRIEL  
 Comment il l'a mouché hey!

Scene	Duration	Panel	Duration
191	02:13	1	01:03



**Dialogue**  
 ADELE  
 Hi!Hi!Hi!

Scene	Duration	Panel	Duration
191	02:13	2	01:10



**Dialogue**  
 PU ADELE  
 Bravo Sébastien



Scene	Duration	Panel	Duration
192	03:06	1	00:16



Scene	Duration	Panel	Duration
192	03:06	2	00:08



**Action Notes**  
SEB fait un clin d'oeil à Angelina

Scene	Duration	Panel	Duration
192	03:06	3	00:18



Scene	Duration	Panel	Duration
192	03:06	4	01:14

NO PANEL

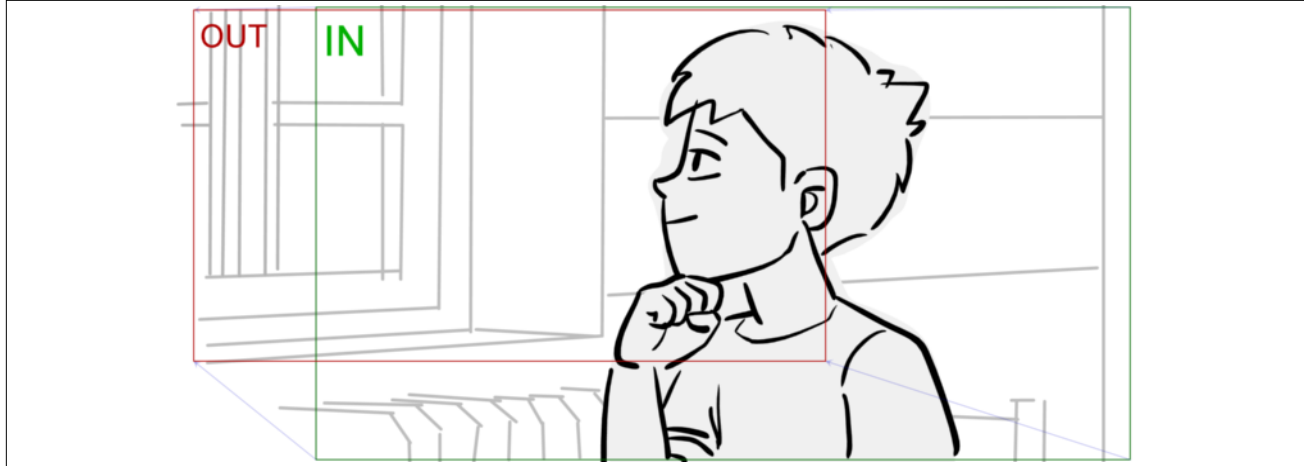

**Action Notes**

SEB se retourne rêveur vers la fenêtre

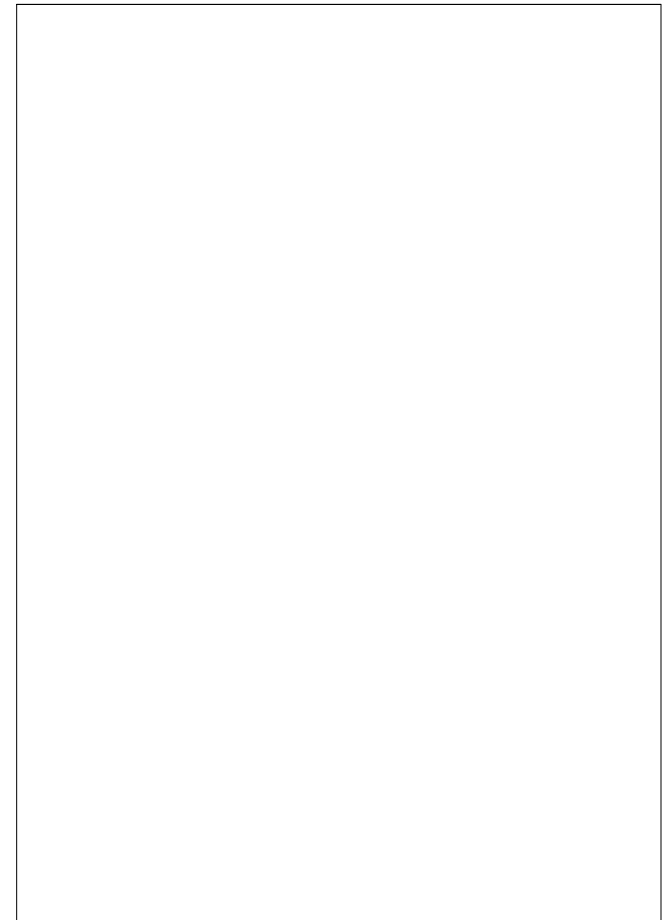
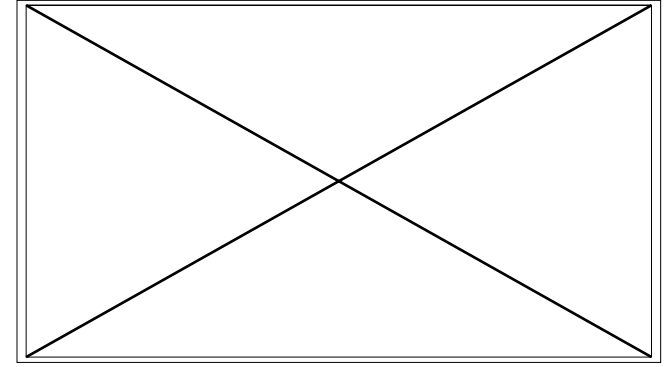



Scene	Duration	Panel	Duration
193	04:13	1	04:13

Dissolve	Duration
	00:12

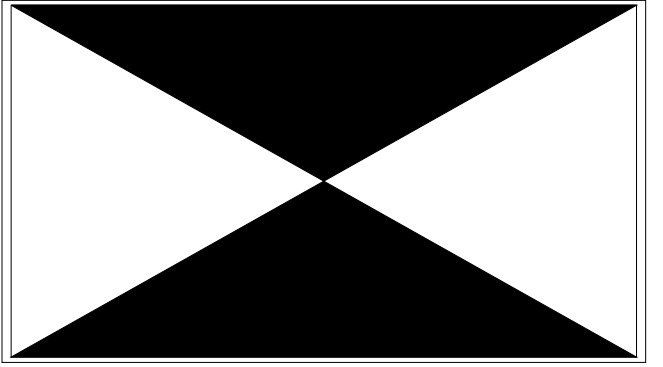
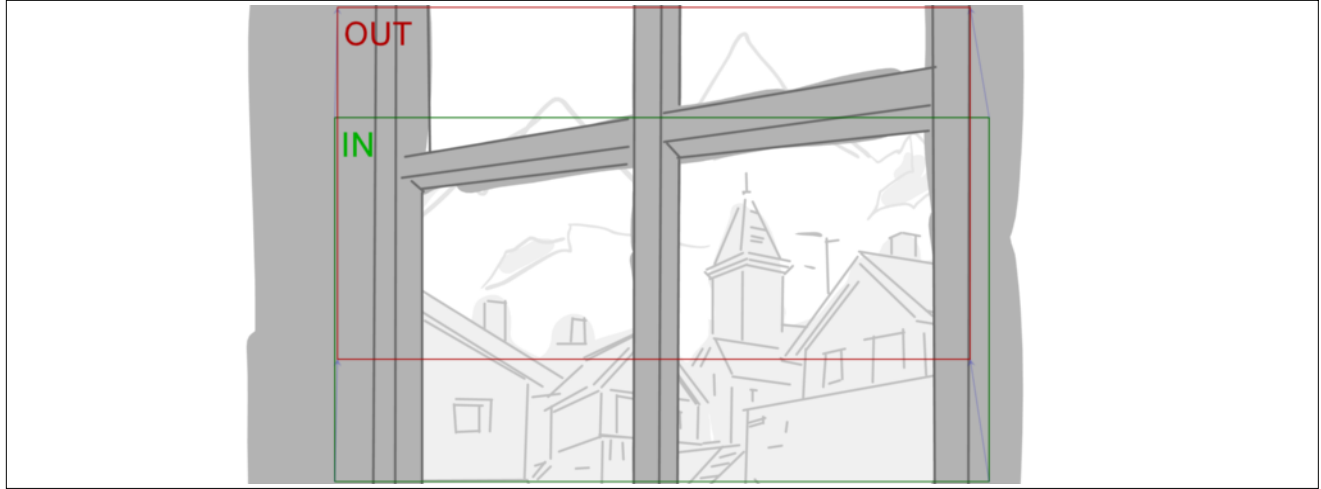

**Action Notes**  
POV son regard s'élève vers la montagne

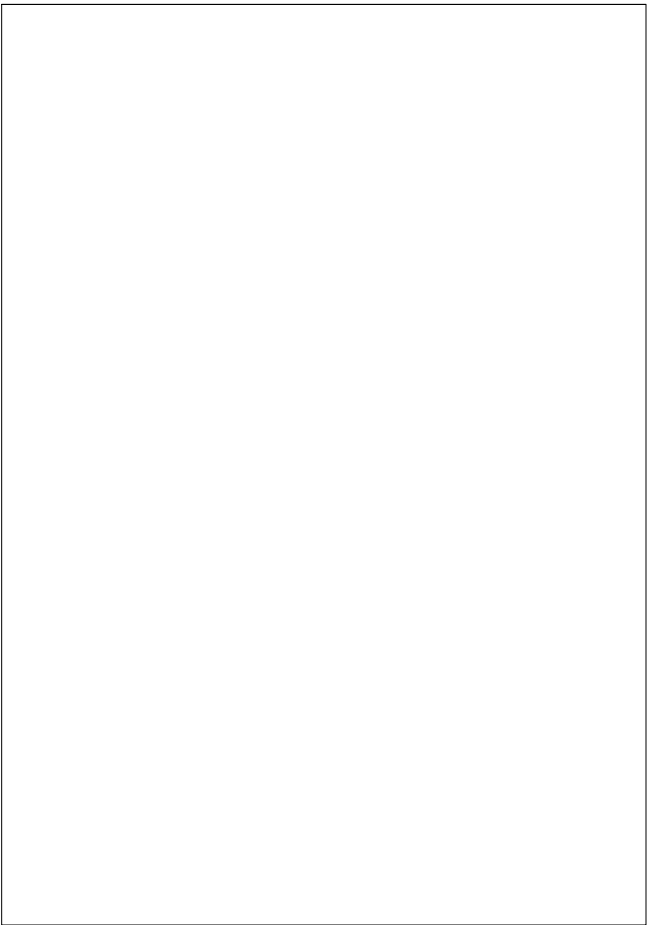



Scene	Duration	Panel	Duration
194	06:16	1	03:22

Scene	Duration	Panel	Duration
194	06:16	2	00:11

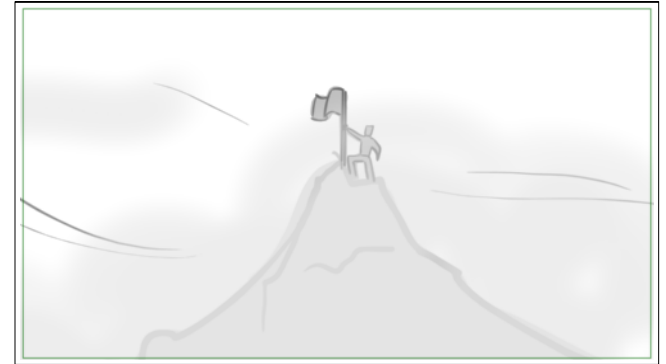
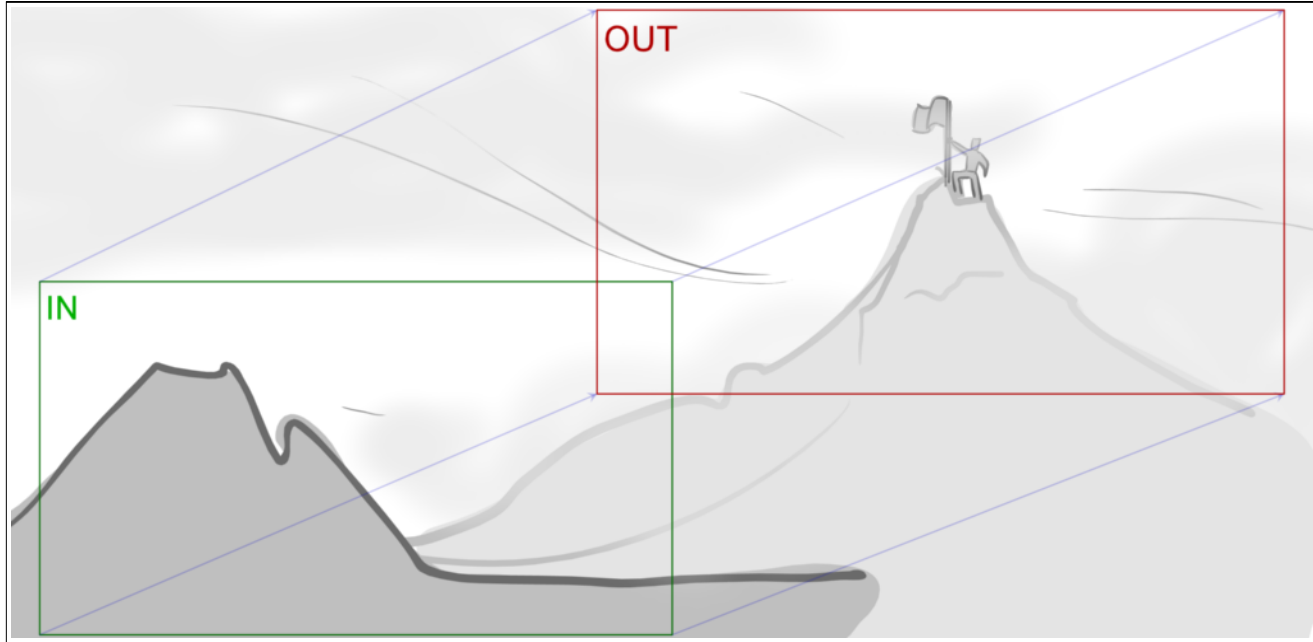

**Action Notes**

silhouette fantômatique de nino debout près du drapeau

**Dialogue**

SFX VENT

**Action Notes**

PAN sommet du pic sans nom  
FX BRUME  
FX VENT



Scene	Duration	Panel	Duration
194	06:16	3	02:08

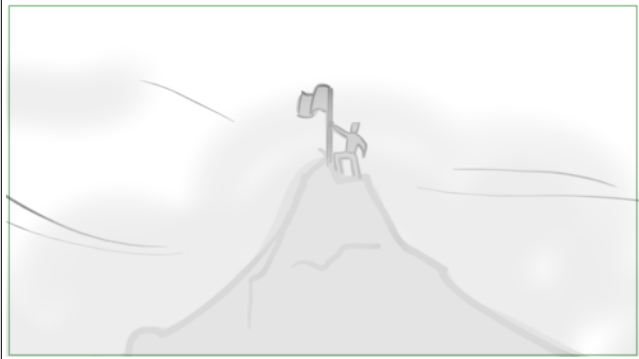

Dissolve	Duration
Dissolve	00:24

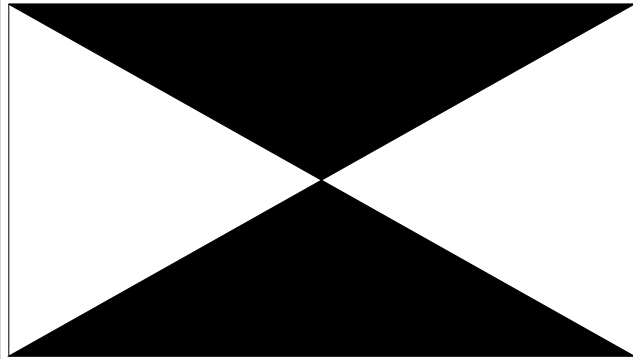

Scene	Duration	Panel	Duration
195	03:05	1	03:05

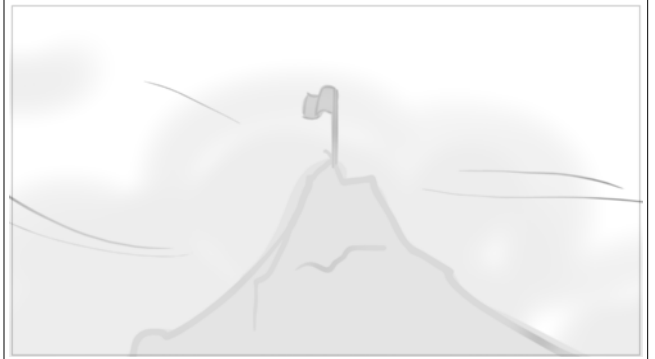

**Action Notes**  
silhouette s'estompe dans la brume