

MAGIC – SAISON 2

Chacun sa voix



Scene	Duration	Panel	Duration
1	02:00	1	02:00



Action Notes

EXT ECOLE - JOUR

Scene	Duration	Panel	Duration
2	03:24	1	00:24

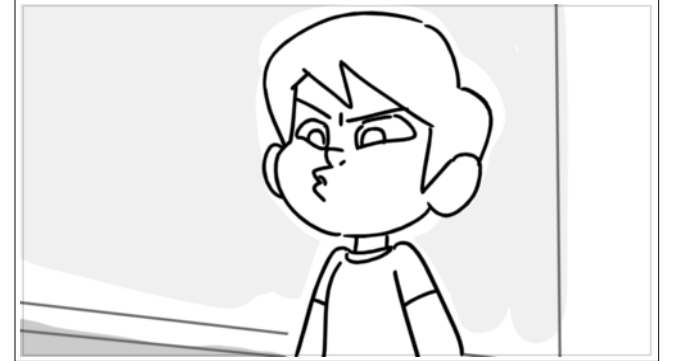

Dialogue

PU TOM (expiration à la dark vador)
Paaaahhhh

Action Notes

1. INT. SALLE DE CLASSE - JOUR
Tom joue Dark Vador



Scene	Duration	Panel	Duration
2	03:24	2	01:01



Dialogue
PU TOM
Ha! Ha! Ha!

Scene	Duration	Panel	Duration
2	03:24	3	01:24



Dialogue
PU TOM
Ha! Ha! Ha!

Scene	Duration	Panel	Duration
3	07:14	1	00:09



Dialogue
1. TOM
Enfin je te retrouve Yoga !

Action Notes
Tom sur l'estrade, sa feuille à la main.

Scene	Duration	Panel	Duration
3	07:14	2	00:04



Scene	Duration	Panel	Duration
3	07:14	3	02:01



Dialogue
 1. TOM
 Te voilà devenu un petit vieillard,

Scene	Duration	Panel	Duration
3	07:14	4	00:11



Dialogue
 1. TOM
 Te voilà devenu un petit vieillard,

Scene	Duration	Panel	Duration
3	07:14	5	01:04



Dialogue

1. TOM
Te voilà devenu un petit vieillard,

Scene	Duration	Panel	Duration
3	07:14	6	01:16



Dialogue

1. TOM
tandis que moi

Scene	Duration	Panel	Duration
3	07:14	7	00:20



Dialogue

1. TOM
je suis...

Action Notes

Mlle Fossette baisse le regard sur son carnet et note

Scene	Duration	Panel	Duration
3	07:14	8	00:09

Scene	Duration	Panel	Duration
3	07:14	9	00:09

Scene	Duration	Panel	Duration
3	07:14	10	00:06



Action Notes
Boulette IN



Scene	Duration	Panel	Duration
4	03:17	1	01:16



Dialogue
2. VICTOR
Un pauvre petit minus

Action Notes
Victor imite la voix fluette de Tom.

Scene	Duration	Panel	Duration
4	03:17	2	00:08



Dialogue
2. VICTOR
Un pauvre petit minus

Scene	Duration	Panel	Duration
4	03:17	3	00:17



Dialogue
2. VICTOR
Un pauvre petit minus

Scene	Duration	Panel	Duration
4	03:17	4	01:01



Dialogue

2. VICTOR
ahahah !

Scene	Duration	Panel	Duration
5	04:12	1	00:24



Scene	Duration	Panel	Duration
5	04:12	2	02:13



Dialogue

3. Mlle FOSSETTE (n'entend pas Victor)
Allez, Tom t'avais bien commencé,

Scene	Duration	Panel	Duration
5	04:12	3	01:00



Dialogue

3. MLE FOSSETTE (n'entend pas Victor)
continue.

Scene	Duration	Panel	Duration
6	10:17	1	00:11



Dialogue

4. TOM
... tandis que moi

Scene	Duration	Panel	Duration
6	10:17	2	00:24



Dialogue

4. TOM
... tandis que moi

Scene	Duration	Panel	Duration
6	10:17	3	01:19



Dialogue

4. TOM
je suis le maître de la galaxie !

Scene	Duration	Panel	Duration
6	10:17	4	00:21



Dialogue

4. TOM
je suis le maître de la galaxie !

Scene	Duration	Panel	Duration
6	10:17	5	02:05



Dialogue

4. TOM
je suis le maître de la galaxie !

Scene	Duration	Panel	Duration
6	10:17	6	01:13



Dialogue
 4. TOM
 je suis le maître de la galaxie !

Scene	Duration	Panel	Duration
6	10:17	7	01:12



Dialogue
 9. LA CLASSE
 < rires >

Scene	Duration	Panel	Duration
6	10:17	8	00:17



Dialogue
 9. LA CLASSE
 < rires >

Scene	Duration	Panel	Duration
6	10:17	9	00:09

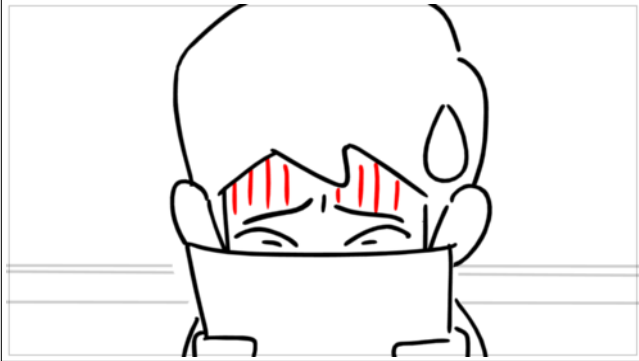

Dialogue
 9. LA CLASSE
 < rires >

Scene	Duration	Panel	Duration
6	10:17	10	00:11



Dialogue
 9. LA CLASSE
 < rires >

Scene	Duration	Panel	Duration
7	01:05	1	01:05

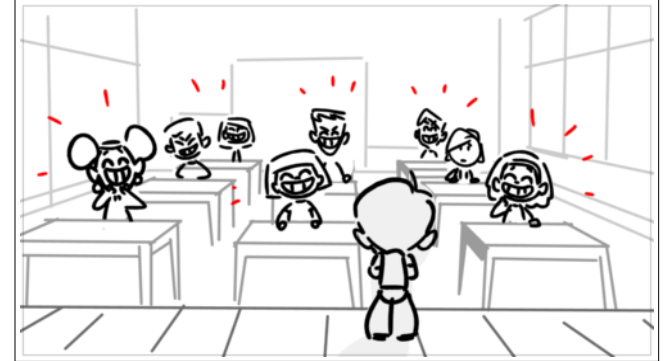

Dialogue
 9. LA CLASSE
 < rires >

Scene	Duration	Panel	Duration
8	05:21	1	01:14



Dialogue
 PU MLE FOSSETTE
 ça suffit les enfants

Scene	Duration	Panel	Duration
8	05:21	2	02:12



Dialogue
 PU MLE FOSSETTE
 Désolée Tom,

Action Notes
 Air désolé de la maitresse

Scene	Duration	Panel	Duration
8	05:21	3	01:11



Dialogue
 PU MLE FOSSETTE
 je vais te donner un autre rôle.



Scene	Duration	Panel	Duration
8	05:21	4	00:09



Scene	Duration	Panel	Duration
9	06:04	1	00:23



Scene	Duration	Panel	Duration
9	06:04	2	00:16



Scene	Duration	Panel	Duration
9	06:04	3	00:07

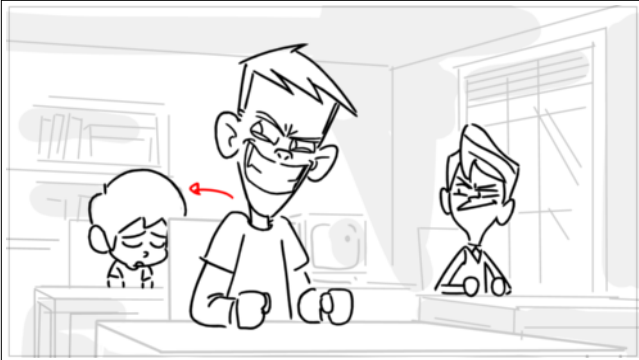

Action Notes
Tom s'assied

Scene	Duration	Panel	Duration
9	06:04	4	00:18



Scene	Duration	Panel	Duration
9	06:04	5	00:09

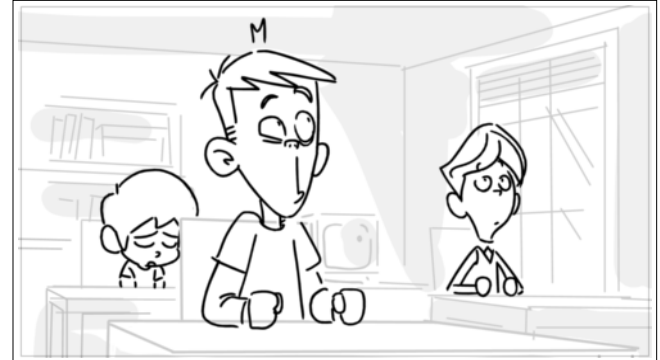

Dialogue
6. Mlle FOSSETTE
Victor,

Scene	Duration	Panel	Duration
9	06:04	6	01:05

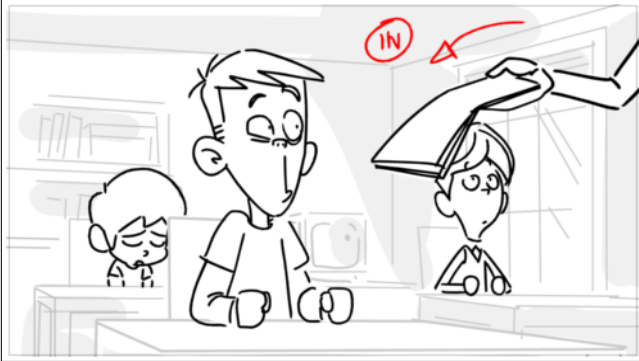

Dialogue

6. MLE FOSSETTE
tu joueras Dark Vapor

Scene	Duration	Panel	Duration
9	06:04	7	01:13



Scene	Duration	Panel	Duration
9	06:04	8	00:13



Dialogue

PU VICTOR
Yes!!!

Scene	Duration	Panel	Duration
10	04:20	1	00:12

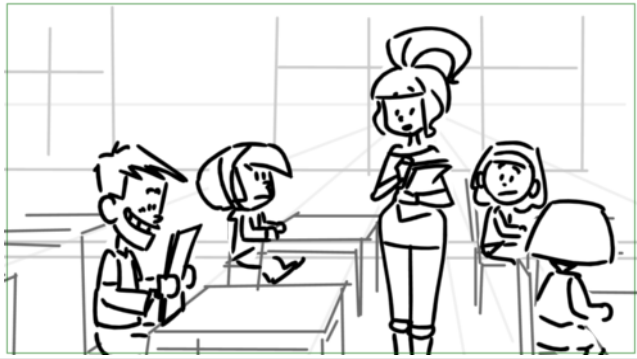
**Dialogue**

6. MLE FOSSETTE
... Jojo,

Scene	Duration	Panel	Duration
10	04:20	2	01:07

**Dialogue**

6. MLE FOSSETTE
tu seras Choubaba

NO PANEL

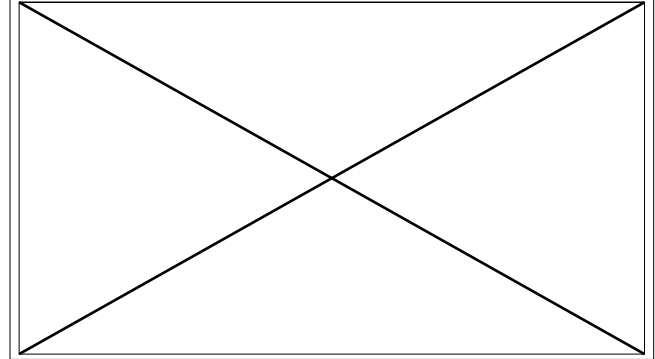



Scene	Duration	Panel	Duration
10	04:20	3	01:15

NO PANEL

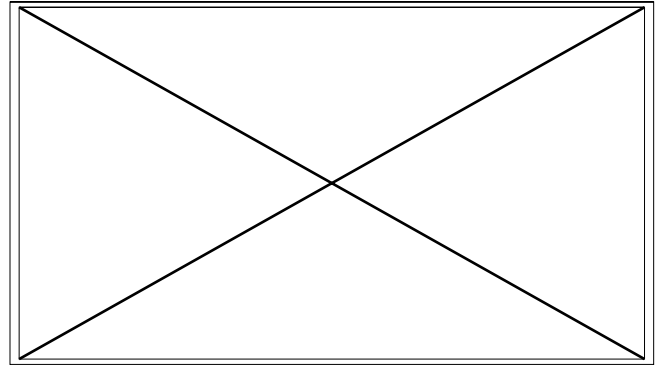

Dialogue
6. MLE FOSSETTE
et enfin, Tom

Action Notes
PAN FOLLOW

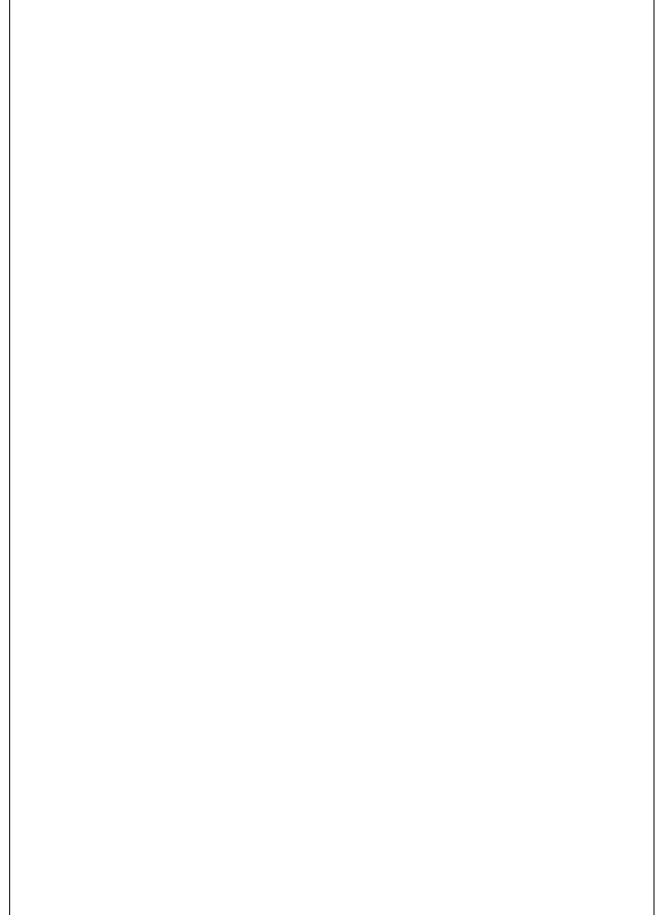

Scene	Duration	Panel	Duration
10	04:20	4	01:11



Dialogue

6. MLE FOSSETTE
tu seras notre Maître Yoga....

Scene	Duration	Panel	Duration
11	07:21	1	00:05



Scene	Duration	Panel	Duration
11	07:21	2	00:16



Dialogue

7. TOM (dégoûté)
Oh bah non !!

Scene	Duration	Panel	Duration
11	07:21	3	00:14



Dialogue

7. TOM
S'il vous plaît !

Scene	Duration	Panel	Duration
11	07:21	4	00:17



Dialogue

7. TOM
Pas Yogaaaaaaa !!

Scene	Duration	Panel	Duration
11	07:21	5	01:17



Dialogue

7. TOM
Pas Yogaaaaaaa !!

Scene	Duration	Panel	Duration
11	07:21	6	01:12



Dialogue

7. TOM
Pas Yogaaaaaaa !!

Scene	Duration	Panel	Duration
11	07:21	7	02:15



Dialogue

10. Mlle FOSSETTE
Tu verras, c'est un très beau rôle,
Tom.

Scene	Duration	Panel	Duration
12	07:21	1	00:20



Dialogue

6. MLE FOSSETTE
Voilà mes enfants, révissez bien !

Scene	Duration	Panel	Duration
12	07:21	2	01:01



Dialogue

6. MLE FOSSETTE
Voilà mes enfants, révissez bien !

Scene	Duration	Panel	Duration
12	07:21	3	00:22



Dialogue

8. VICTOR
Ahahahah !!

Scene	Duration	Panel	Duration
12	07:21	4	01:15



Dialogue

8. VICTOR
S'il vous plaît ! Pas Yogaaaaaaa » !!

Scene	Duration	Panel	Duration
12	07:21	5	01:21



Dialogue

8. VICTOR
S'il vous plaît ! Pas Yogaaaaaaa » !!

Scene	Duration	Panel	Duration
12	07:21	6	01:17



Dialogue

8. VICTOR
Ahahahah !! S'il vous plaît ! Pas
Yogaaaaaaa » !!

Scene	Duration	Panel	Duration
13	02:00	1	00:14



Scene	Duration	Panel	Duration
13	02:00	2	01:11

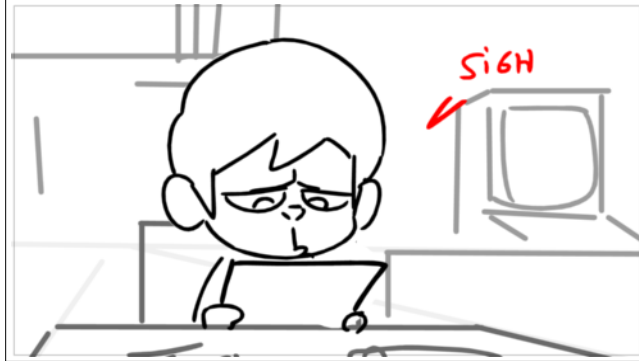

Scene	Duration	Panel	Duration
14	01:05	1	01:05

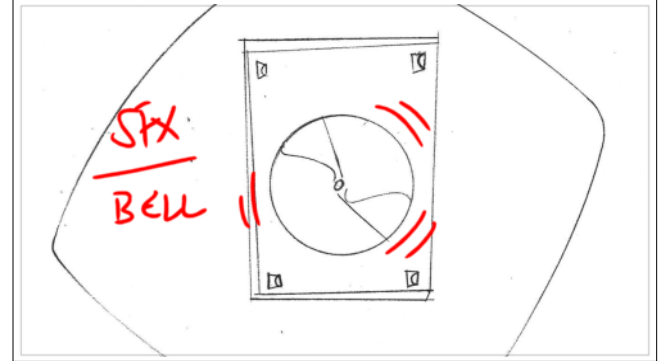

Dialogue
SFX Sonnerie

Scene	Duration	Panel	Duration
15	03:07	1	00:12



Action Notes

INT ECOLE COULOIR

Scene	Duration	Panel	Duration
15	03:07	2	01:11



Dialogue

11. Tom
Rahhhhhh, je déteste ma voix.

Scene	Duration	Panel	Duration
15	03:07	3	01:09



Dialogue

11. Tom
Rahhhhhh, je déteste ma voix.

Action Notes

TOM et JOJO IN

Scene	Duration	Panel	Duration
16	17:17	1	00:14

Scene	Duration	Panel	Duration
16	17:17	2	00:23

Scene	Duration	Panel	Duration
16	17:17	3	01:06



Dialogue
 11. Tom
 Elle est ridicule !

Dialogue
 11. Tom
 Elle est ridicule !

Dialogue
 11. Tom
 C'est à cause d'elle que je vais jouer

Action Notes
 PAN BG

Scene	Duration	Panel	Duration
16	17:17	4	00:10



Dialogue
 11. Tom
 ce nul de Yoga.

Scene	Duration	Panel	Duration
16	17:17	5	01:09



Dialogue
 11. Tom
 ce nul de Yoga.

Scene	Duration	Panel	Duration
16	17:17	6	01:00



Dialogue
 12. Jojo
 Bah quoi, il est très bien ton personnage.

Scene	Duration	Panel	Duration
16	17:17	7	01:24



Dialogue
 12. Jojo
 Bah quoi, il est très bien ton personnage.

Scene	Duration	Panel	Duration
16	17:17	8	02:01



Dialogue
 12. Jojo
 Regarde, t'as plein de répliques !

Scene	Duration	Panel	Duration
16	17:17	9	02:02



Dialogue
 12. Jojo
 Moi je dis que des trucs comme

Scene	Duration	Panel	Duration
16	17:17	10	01:03



Dialogue
12. Jojo
« ARrrrrghhh » ...

Scene	Duration	Panel	Duration
16	17:17	11	01:20



Dialogue
12. Jojo
« ARrrrrghhh » ...

Scene	Duration	Panel	Duration
16	17:17	12	00:23



Dialogue
12. Jojo
ou

Scene	Duration	Panel	Duration
16	17:17	13	01:05



Dialogue
 12. Jojo
 « RUghhharr »...

Scene	Duration	Panel	Duration
16	17:17	14	01:02



Dialogue
 12. Jojo
 « RUghhharr »...

Scene	Duration	Panel	Duration
17	04:14	1	00:10



Dialogue
 13. TOM (pensif)
 Si seulement je pouvais avoir déjà une voix de grand...

Scene	Duration	Panel	Duration
17	04:14	2	02:06

Scene	Duration	Panel	Duration
17	04:14	3	01:04

Scene	Duration	Panel	Duration
17	04:14	4	00:11

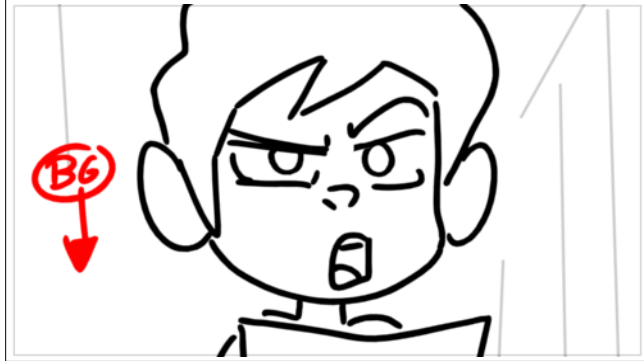

Dialogue

13. TOM (pensif)
Si seulement je pouvais avoir déjà une voix de grand...

Dialogue

13. TOM (pensif)
Si seulement je pouvais avoir déjà une voix de grand...

Dialogue

13. TOM
Mais...

Scene	Duration	Panel	Duration
17	04:14	5	00:08



Dialogue
13. TOM
Mais...

Scene	Duration	Panel	Duration
18	03:15	1	00:15



Scene	Duration	Panel	Duration
18	03:15	2	01:09



Dialogue
13. TOM
Mais oui !



Scene	Duration	Panel	Duration
18	03:15	3	00:11

Scene	Duration	Panel	Duration
18	03:15	4	01:05

Scene	Duration	Panel	Duration
19	00:24	1	00:24



Action Notes

EXT MAISON FEERIKSEN



Scene	Duration	Panel	Duration
20	01:16	1	00:13

Scene	Duration	Panel	Duration
20	01:16	2	00:13

Scene	Duration	Panel	Duration
20	01:16	3	00:15

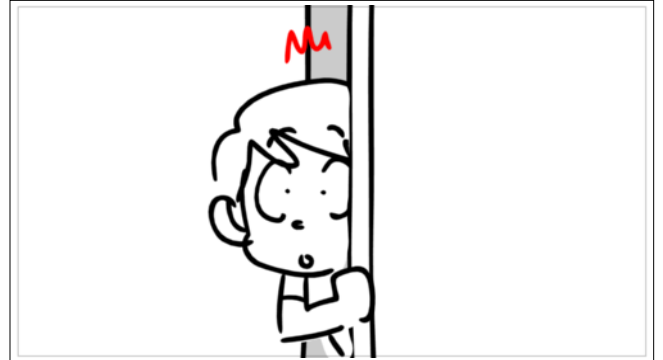
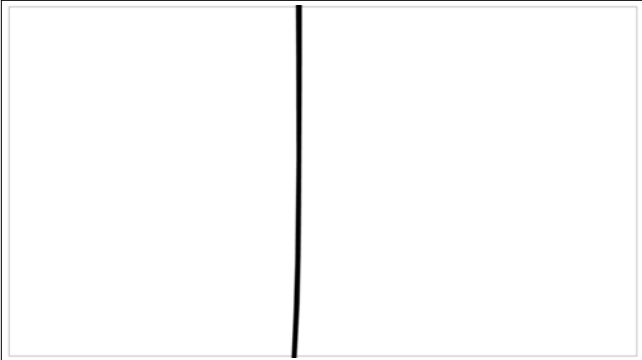

Action Notes
INT CHAMBRE DES PARENTS JOUR



Scene	Duration	Panel	Duration
21	03:21	1	00:17



Scene	Duration	Panel	Duration
21	03:21	2	00:17



Scene	Duration	Panel	Duration
21	03:21	3	00:18





Scene	Duration	Panel	Duration
21	03:21	4	00:12



Scene	Duration	Panel	Duration
21	03:21	5	00:11



Scene	Duration	Panel	Duration
21	03:21	6	00:21



Action Notes

Tom cherche la baguette



Scene	Duration	Panel	Duration
22	01:15	1	00:11

Scene	Duration	Panel	Duration
22	01:15	2	00:12

Scene	Duration	Panel	Duration
22	01:15	3	00:17



Action Notes
INT TIROIR

Scene	Duration	Panel	Duration
23	06:14	1	00:16



Scene	Duration	Panel	Duration
23	06:14	2	00:13



Scene	Duration	Panel	Duration
23	06:14	3	00:09



Action Notes

Tom referme le tiroir



Scene	Duration	Panel	Duration
23	06:14	4	00:18



Action Notes
puis ouvre le second

Scene	Duration	Panel	Duration
23	06:14	5	00:16



Scene	Duration	Panel	Duration
23	06:14	6	00:18



Scene	Duration	Panel	Duration
23	06:14	7	00:24

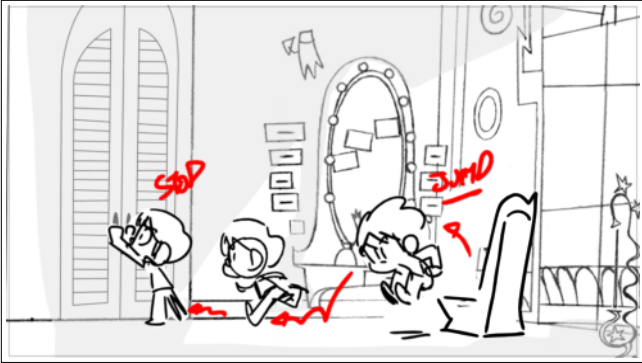

Scene	Duration	Panel	Duration
23	06:14	8	00:15

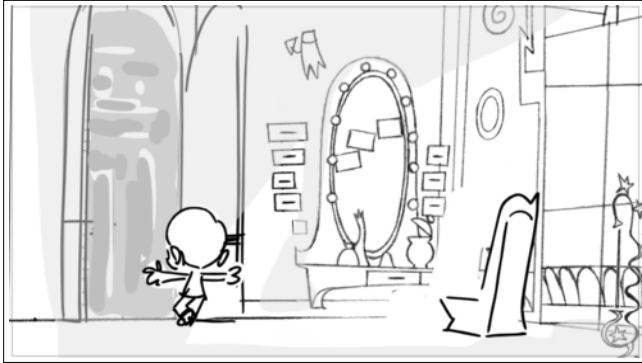

Scene	Duration	Panel	Duration
23	06:14	9	00:16

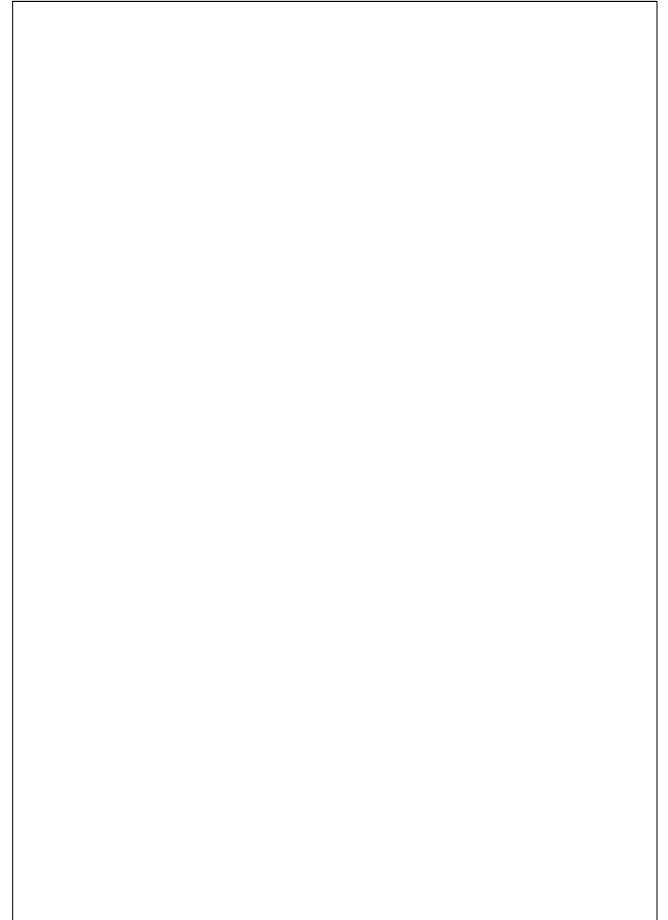
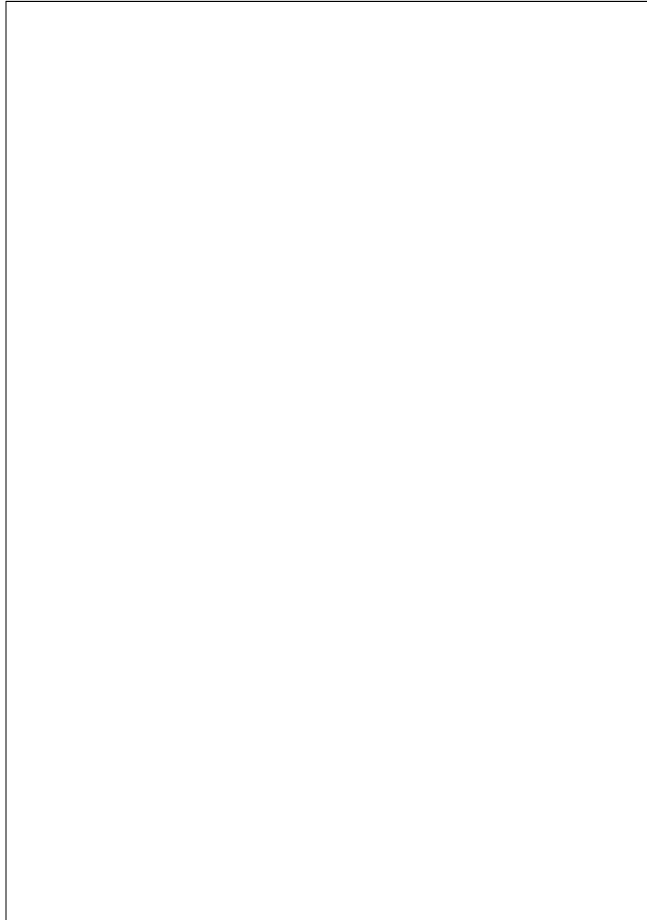
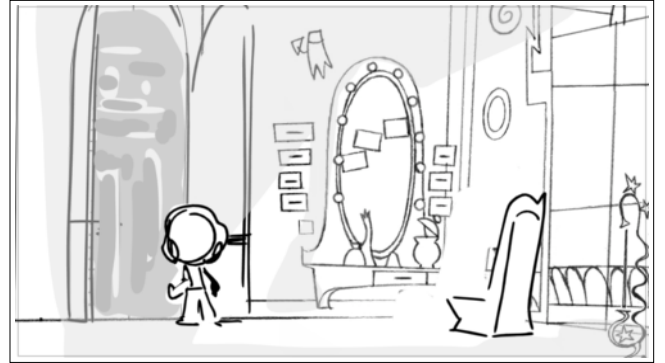

Scene	Duration	Panel	Duration
23	06:14	10	00:19



Scene	Duration	Panel	Duration
24	04:04	1	00:09

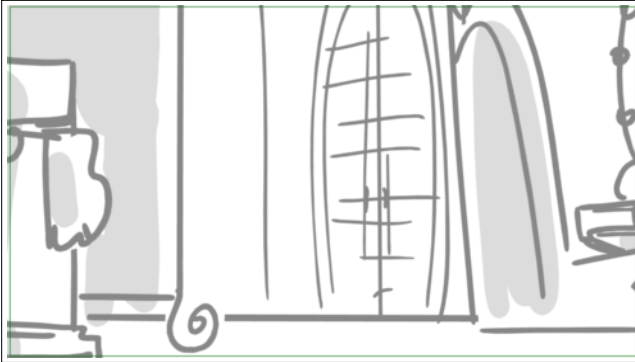

Scene	Duration	Panel	Duration
24	04:04	2	01:00

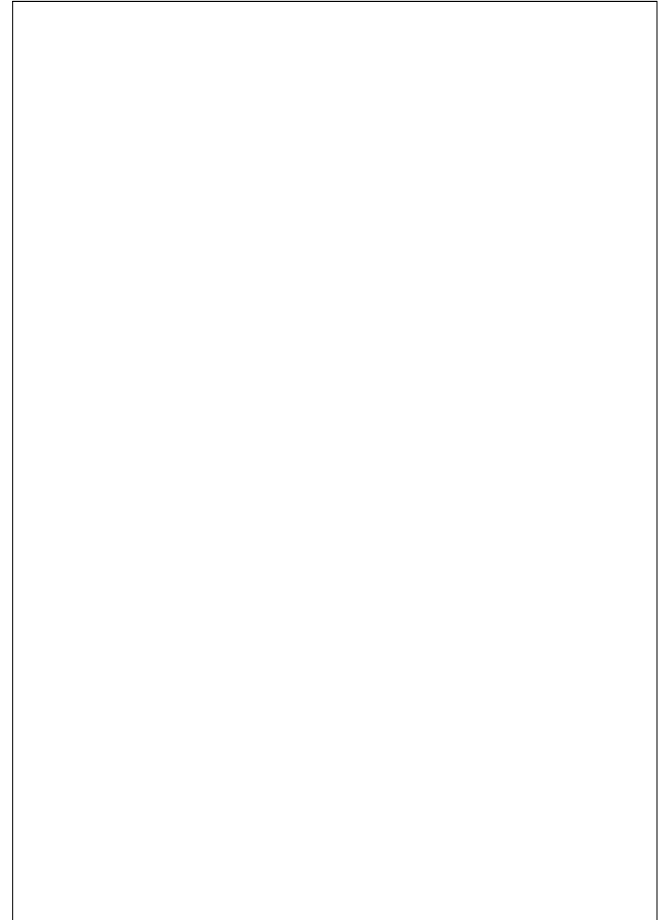
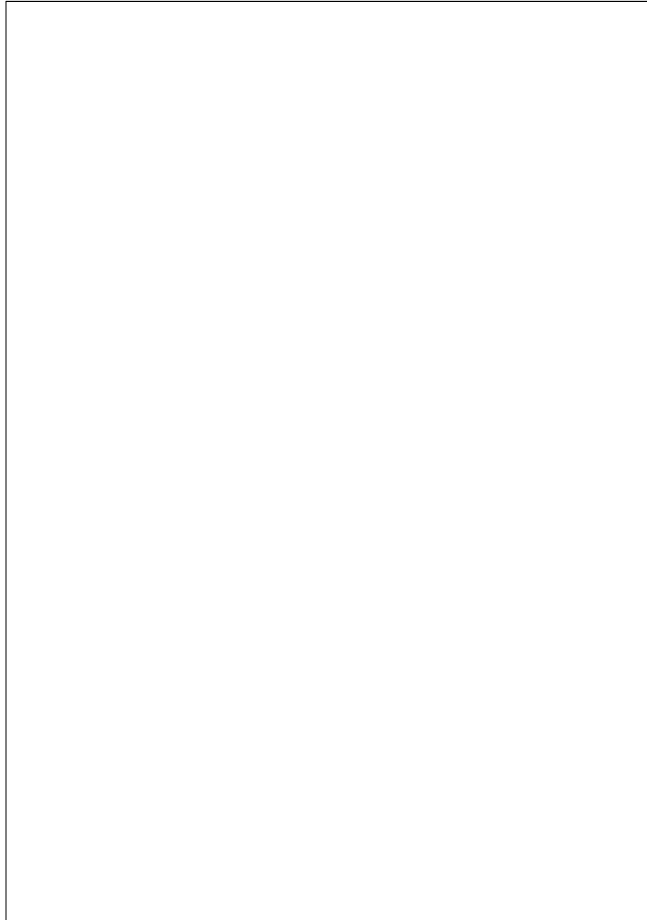



Scene	Duration	Panel	Duration
24	04:04	3	00:18

Scene	Duration	Panel	Duration
24	04:04	4	00:15

NO PANEL

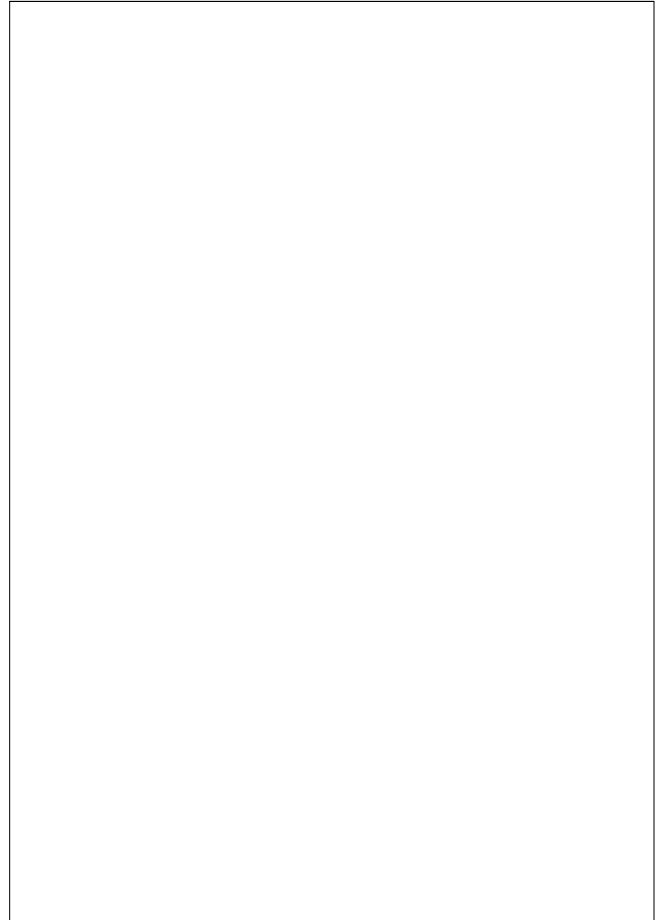
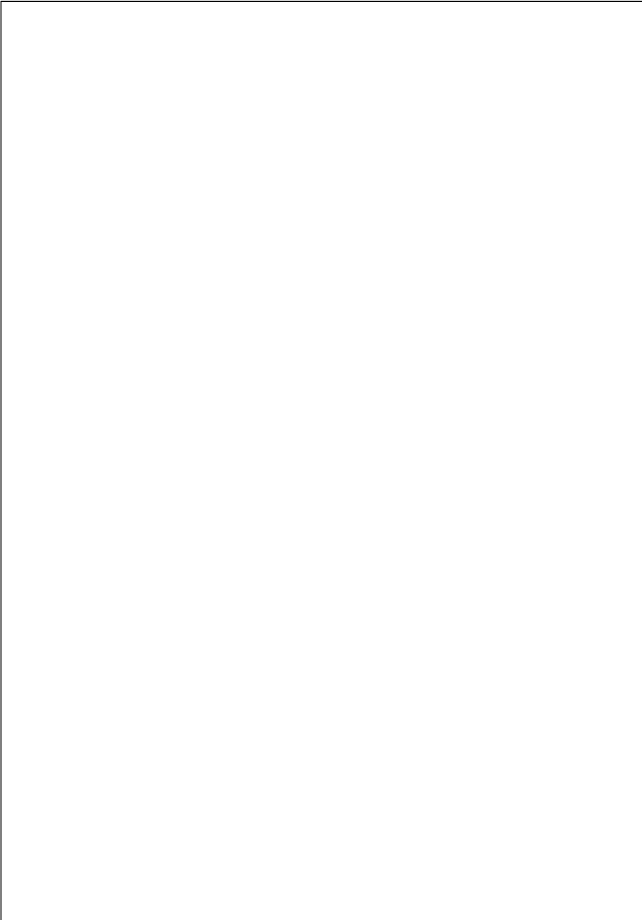
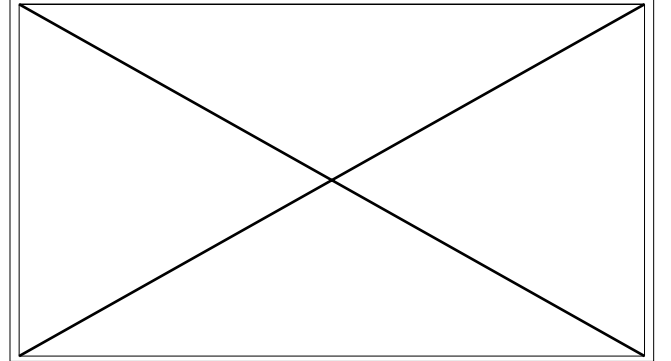



Scene	Duration	Panel	Duration
24	04:04	5	00:12

Scene	Duration	Panel	Duration
24	04:04	6	01:00

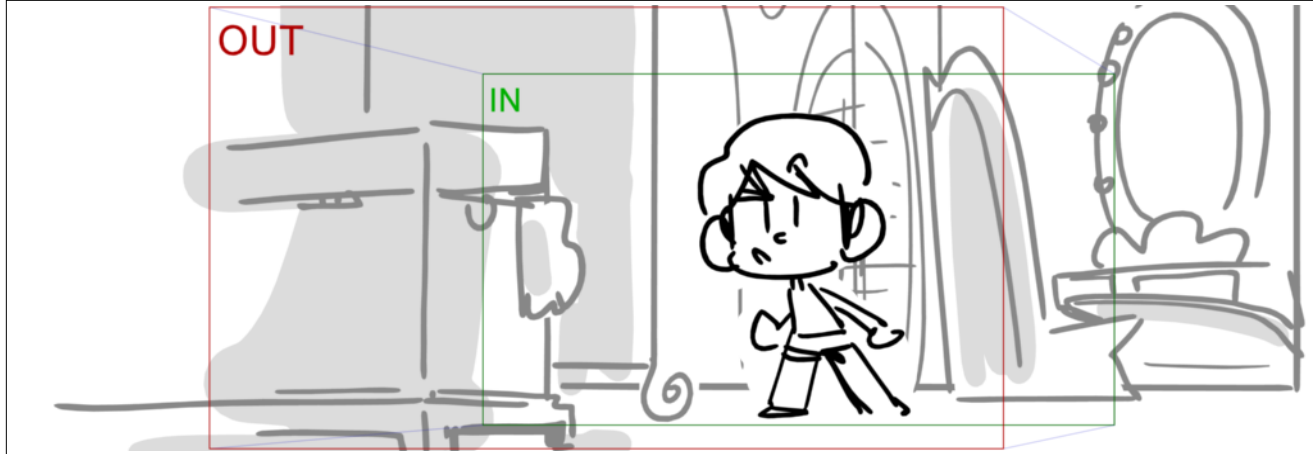

Action Notes

Tom avise la coffre

Scene	Duration	Panel	Duration
25	01:22	1	00:09

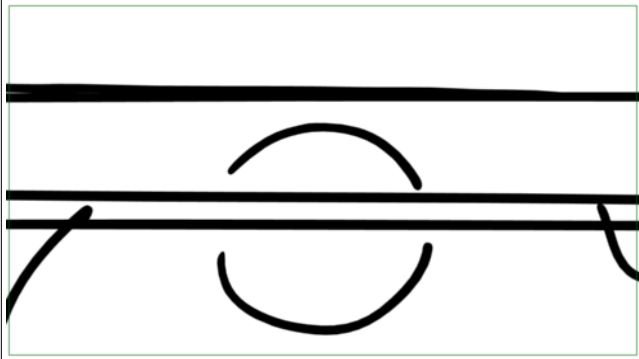

Scene	Duration	Panel	Duration
25	01:22	2	00:13

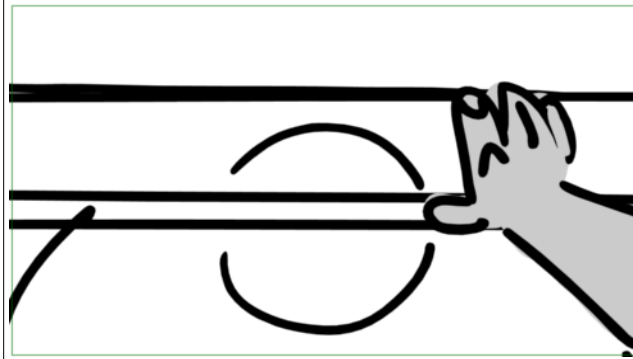

Action Notes
Main de Tom IN

Scene	Duration	Panel	Duration
25	01:22	3	01:00

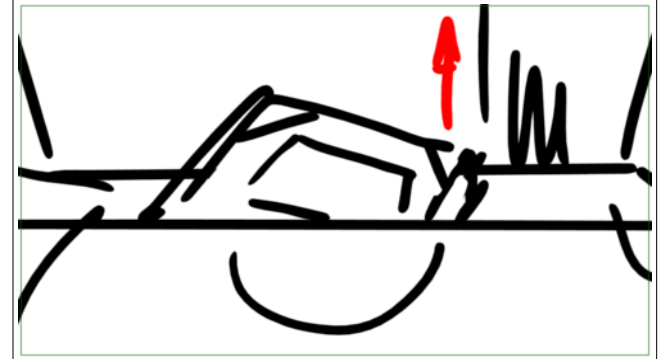

Action Notes
ouvre le coffre



Scene	Duration	Panel	Duration
26	04:10	1	00:18

Scene	Duration	Panel	Duration
26	04:10	2	02:02

Scene	Duration	Panel	Duration
26	04:10	3	01:15

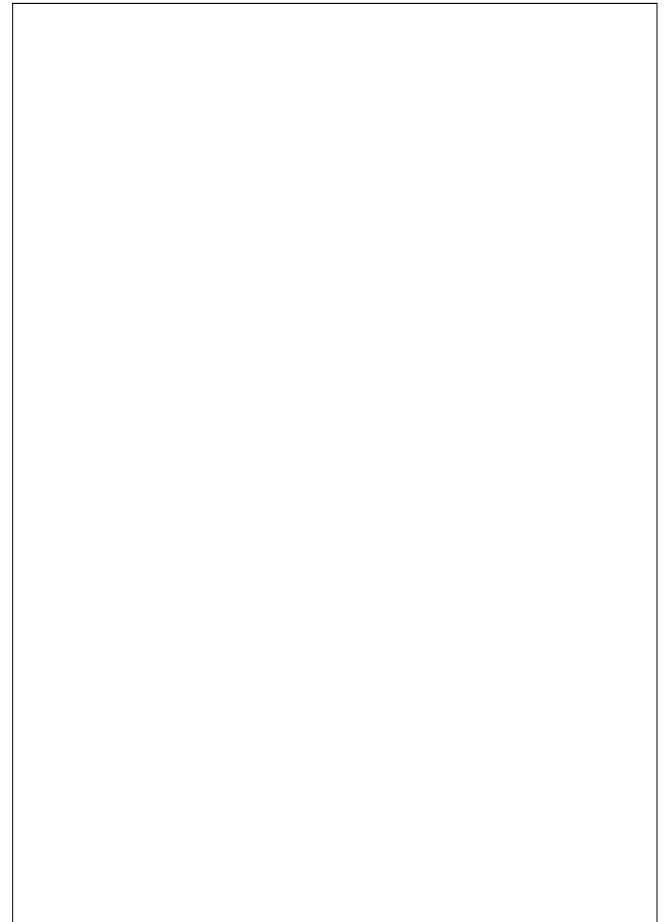
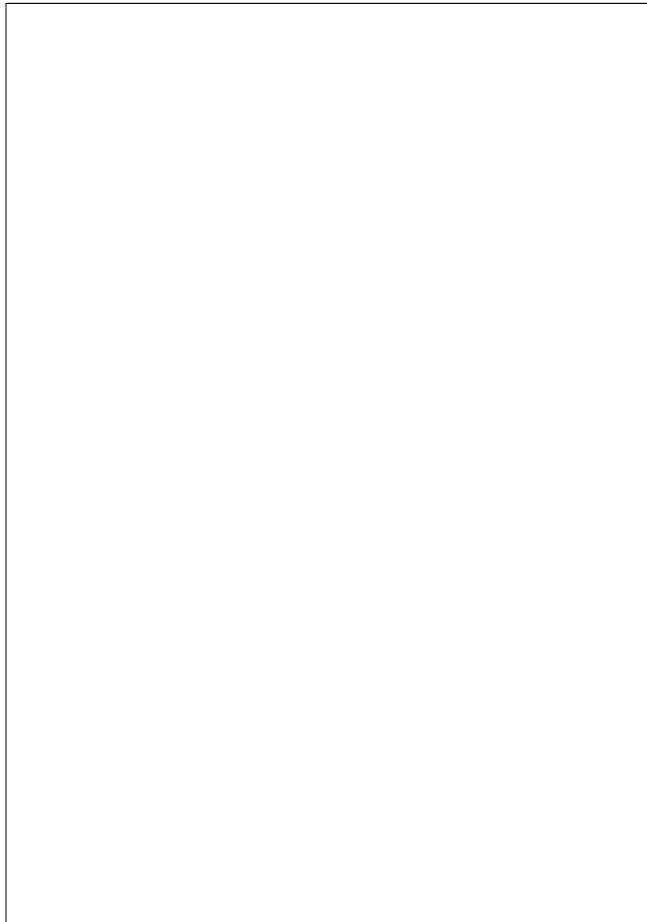
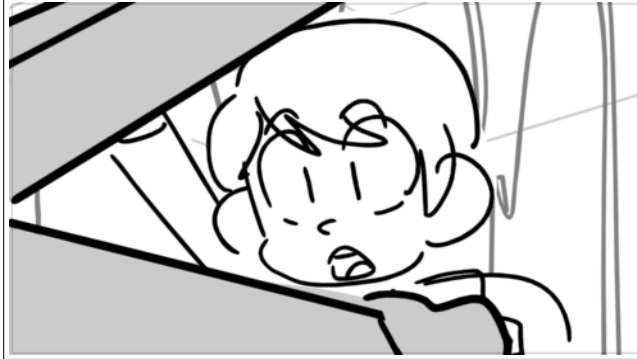
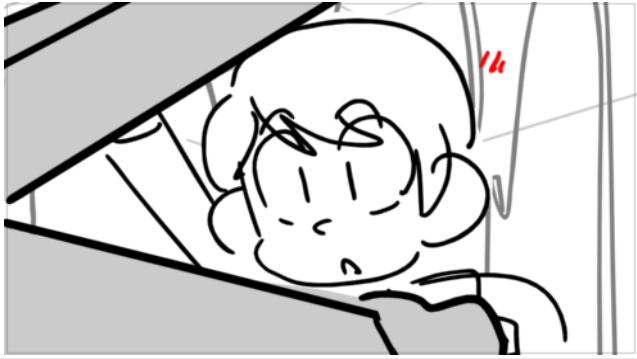



Scene	Duration	Panel	Duration
27	01:17	1	00:18



Action Notes

3. INT. CHAMBRE DE TOM- JOUR

Scene	Duration	Panel	Duration
27	01:17	2	00:07



Action Notes

Main de Tom IN

Scene	Duration	Panel	Duration
27	01:17	3	00:06



Action Notes

ouvre le grimoire

Scene	Duration	Panel	Duration
27	01:17	4	00:11



Scene	Duration	Panel	Duration
28	05:08	1	02:16



Scene	Duration	Panel	Duration
28	05:08	2	00:05



Dialogue

14. Tom
 « Changer un loup-garou en caniche

Action Notes

Tom tourne une page

Scene	Duration	Panel	Duration
28	05:08	3	00:04



Scene	Duration	Panel	Duration
28	05:08	4	02:01



Scene	Duration	Panel	Duration
28	05:08	5	00:07



Dialogue

14. Tom
 « changer de nez », voir page
 Pinocchio...

Scene	Duration	Panel	Duration
29	05:15	1	00:06



Scene	Duration	Panel	Duration
29	05:15	2	00:21



Scene	Duration	Panel	Duration
29	05:15	3	01:00



Dialogue

14. Tom

Ahh ça y est :

Scene	Duration	Panel	Duration
29	05:15	4	00:24



Dialogue

14. Tom
« changer de voix » !!

Scene	Duration	Panel	Duration
29	05:15	5	02:04



Dialogue

15. TOM
« Motus et bouche décousue que ma voix
s...

Scene	Duration	Panel	Duration
29	05:15	6	00:10



Dialogue

15. TOM
« Motus et bouche décousue que ma voix
s...

Scene	Duration	Panel	Duration
30	02:15	1	00:04

Scene	Duration	Panel	Duration
30	02:15	2	00:23

NO PANEL

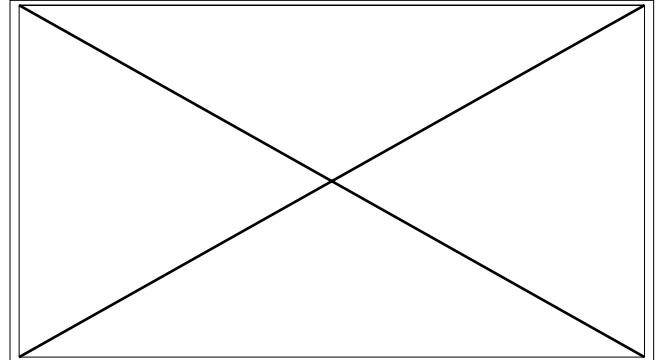

Dialogue
 PU TOM
 Pas s'échange!

Dialogue
 PU TOM
 Pas s'échange!

Action Notes
 FX magique sort du grimoire

Scene	Duration	Panel	Duration
30	02:15	3	01:13

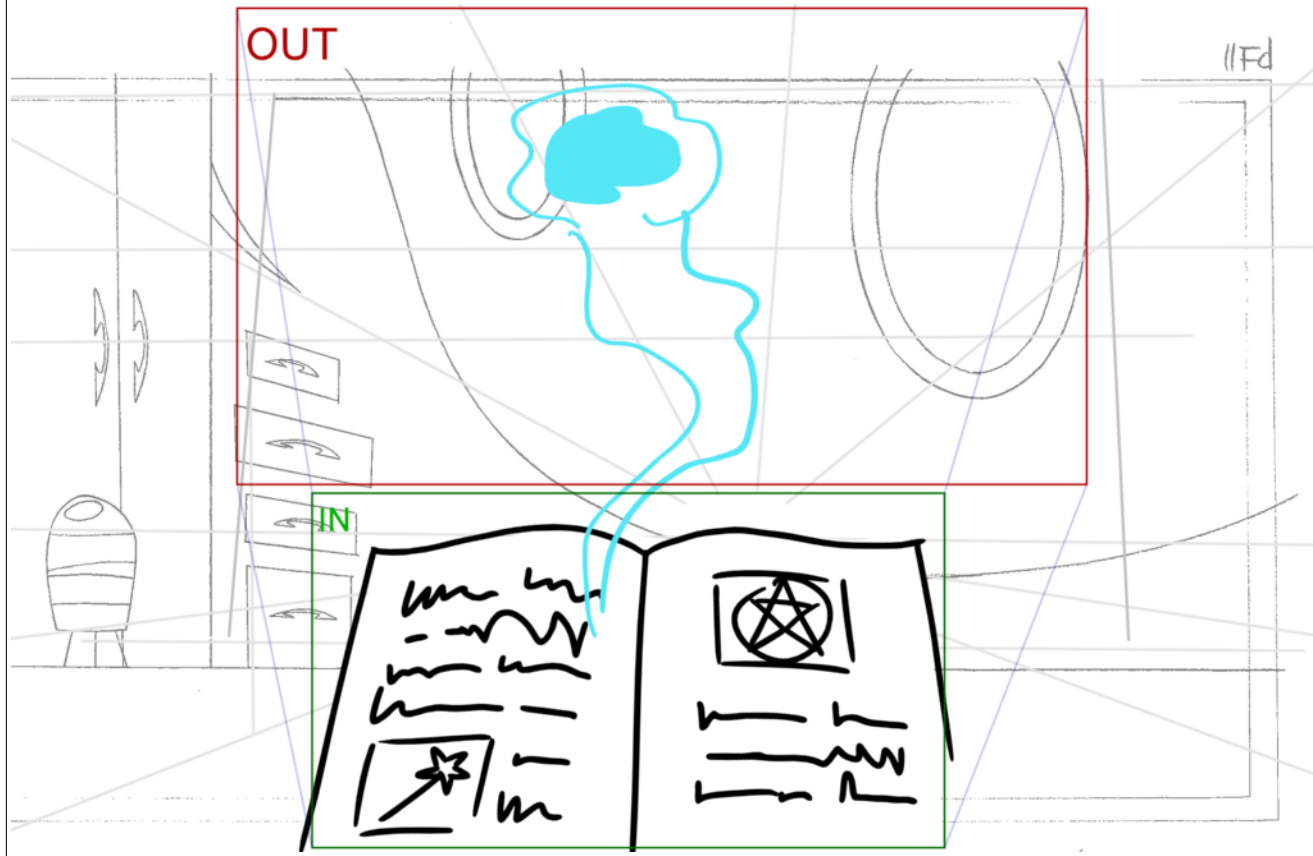

Scene	Duration	Panel	Duration
31	02:11	1	00:10



Dialogue

15. TOM
 « Motus et bouche décousue que ma voix
 s...

Scene	Duration	Panel	Duration
31	02:11	2	00:18



Dialogue

15. TOM
 « Motus et bouche décousue que ma voix
 s...

Scene	Duration	Panel	Duration
31	02:11	3	00:17

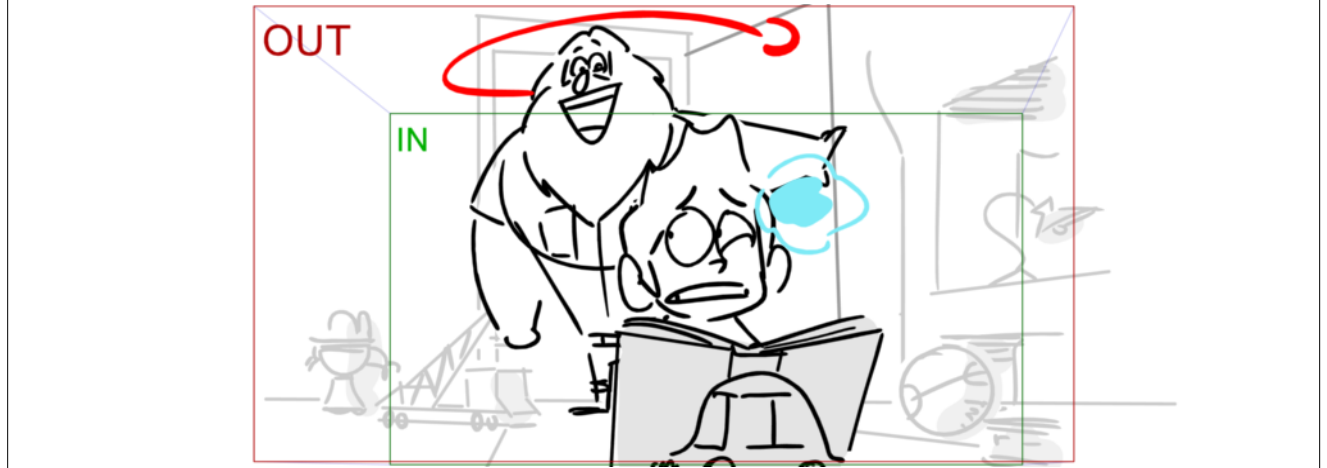

Dialogue

16. TOM
change ! »

Action Notes

Gregor IN

Scene	Duration	Panel	Duration
31	02:11	4	00:16



Dialogue
 16. TOM
change ! »

Scene	Duration	Panel	Duration
32	04:00	1	00:09



Dialogue
 16. TOM
 Se change !!! Se change !!!

Scene	Duration	Panel	Duration
32	04:00	2	00:07



Dialogue
 16. TOM
 Se change !!! Se change !!!



Scene	Duration	Panel	Duration
32	04:00	3	00:12

Scene	Duration	Panel	Duration
32	04:00	4	00:16

Scene	Duration	Panel	Duration
32	04:00	5	00:09

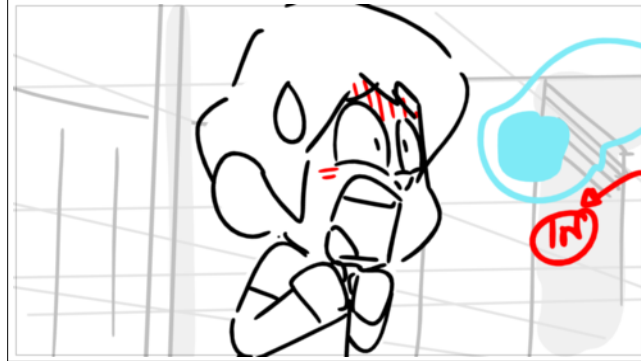

Dialogue
 16. TOM
 Se change !!! Se change !!!

Dialogue
 16. TOM
 Se change !!! Se change !!!

Dialogue
 PU TOM
 Gargl!

Action Notes
 FX IN dans la bouche de Tom

Scene	Duration	Panel	Duration
32	04:00	6	00:23



Scene	Duration	Panel	Duration
32	04:00	7	00:07

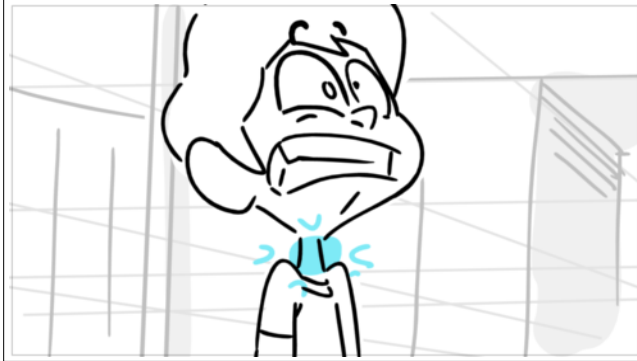

Dialogue
 17. TOM
 HIC !

Action Notes
 Hoquet de Tom

Scene	Duration	Panel	Duration
32	04:00	8	00:10



Action Notes
 FX ressort

Scene	Duration	Panel	Duration
32	04:00	9	00:07



Scene	Duration	Panel	Duration
33	02:16	1	00:08



Dialogue
 PU GREGOR
 Tom! tu as encore volé le grimoire de
 maman!

Scene	Duration	Panel	Duration
33	02:16	2	00:04



Dialogue
 17. GREGOR
 Gargl !

Scene	Duration	Panel	Duration
33	02:16	3	00:20



Scene	Duration	Panel	Duration
33	02:16	4	00:09



Dialogue

17. GREGOR
HIC !

Scene	Duration	Panel	Duration
33	02:16	5	00:17



Scene	Duration	Panel	Duration
33	02:16	6	00:08



Scene	Duration	Panel	Duration
34	01:15	1	00:10



Scene	Duration	Panel	Duration
34	01:15	2	00:05

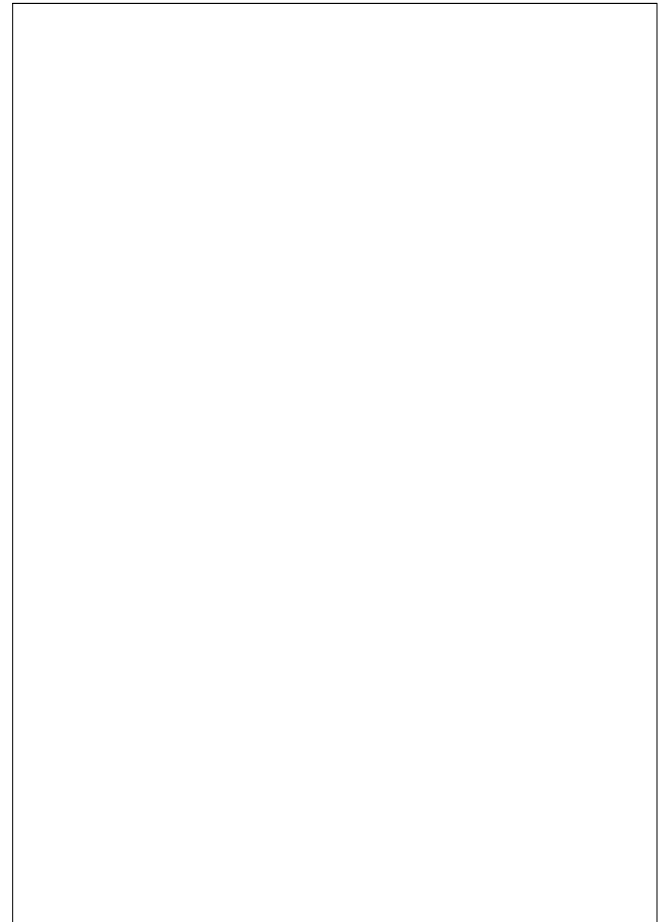
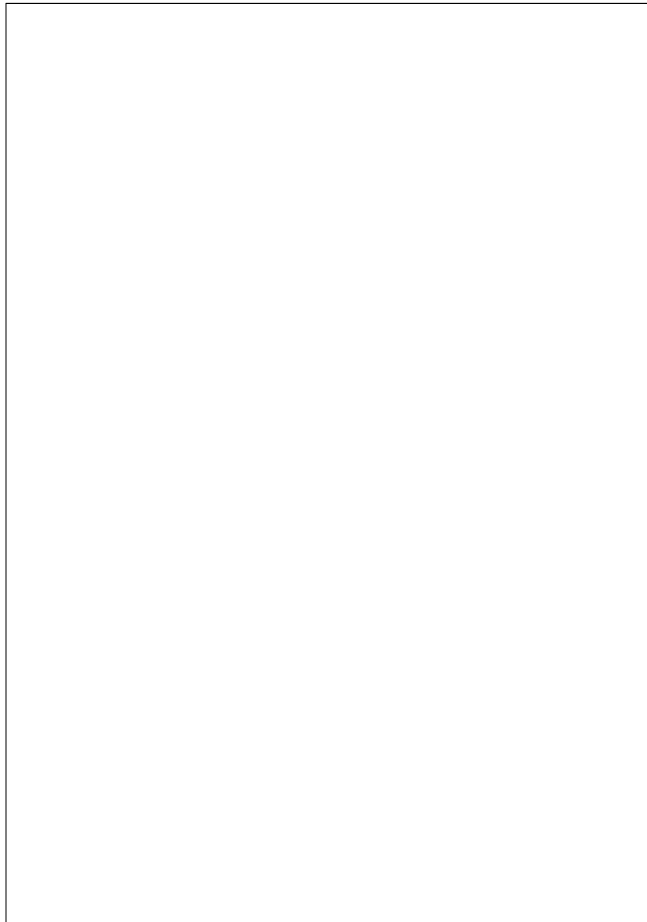



Scene	Duration	Panel	Duration
34	01:15	3	00:06

Scene	Duration	Panel	Duration
34	01:15	4	00:05

Scene	Duration	Panel	Duration
34	01:15	5	00:06

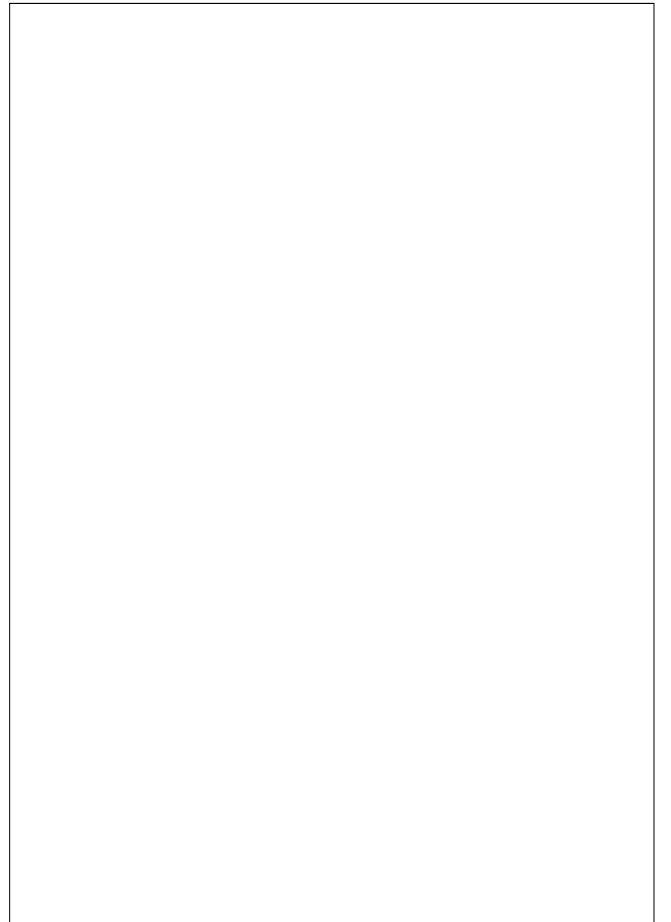
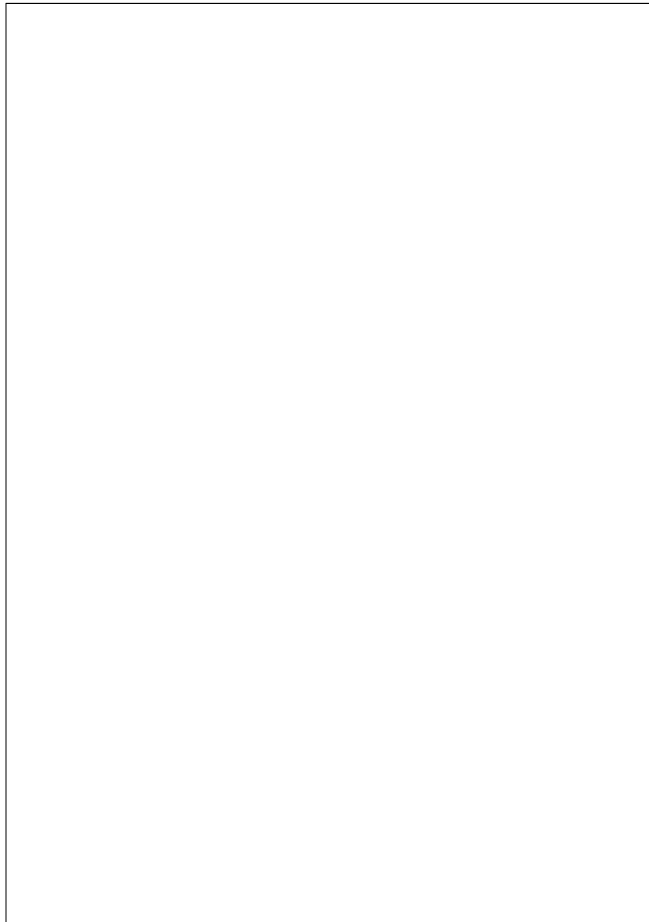

Scene	Duration	Panel	Duration
34	01:15	6	00:08



Scene	Duration	Panel	Duration
35	02:09	1	00:12



Scene	Duration	Panel	Duration
35	02:09	2	00:17

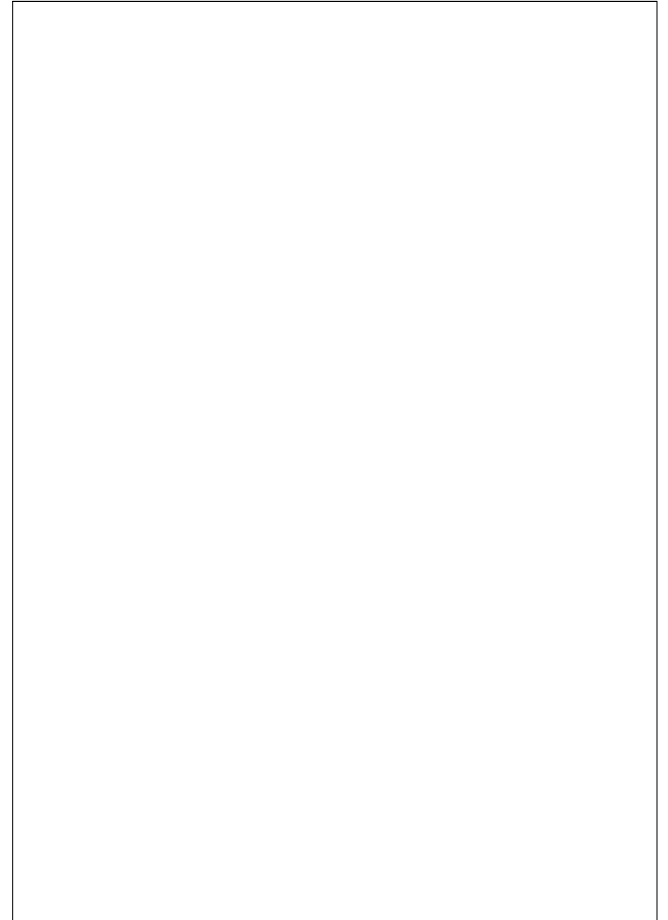
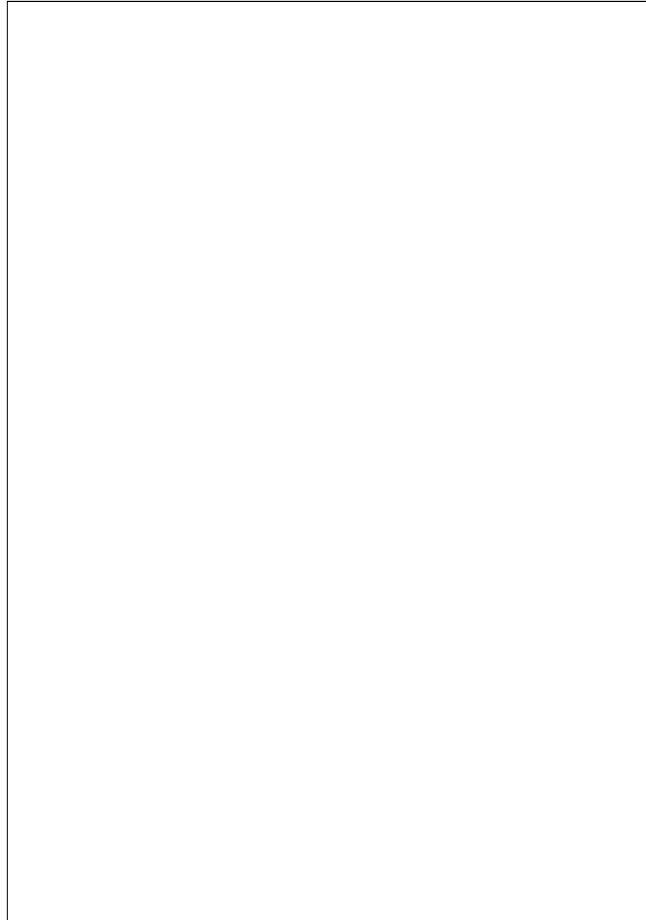
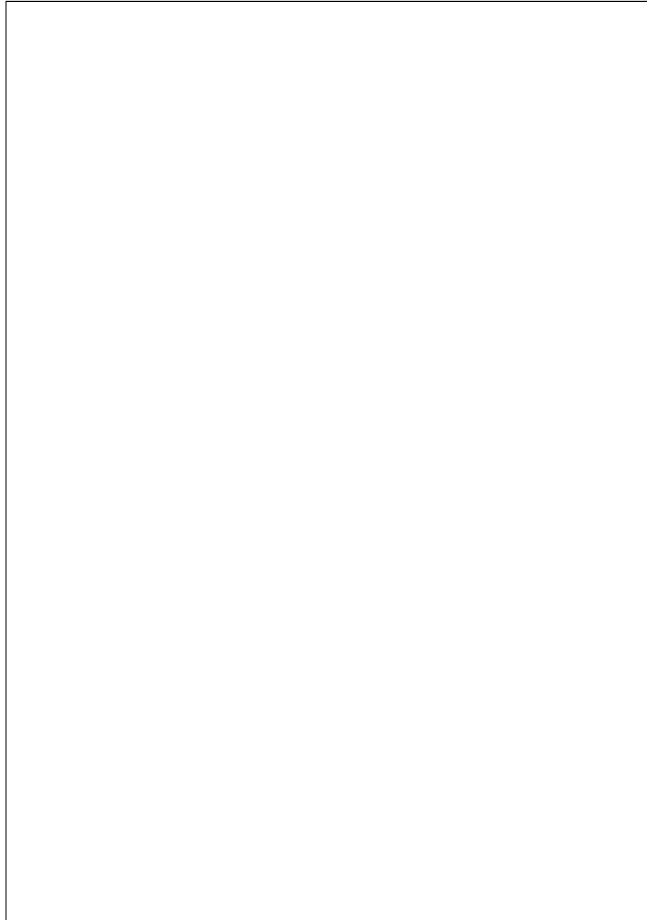



Scene	Duration	Panel	Duration
35	02:09	3	00:07

NO PANEL

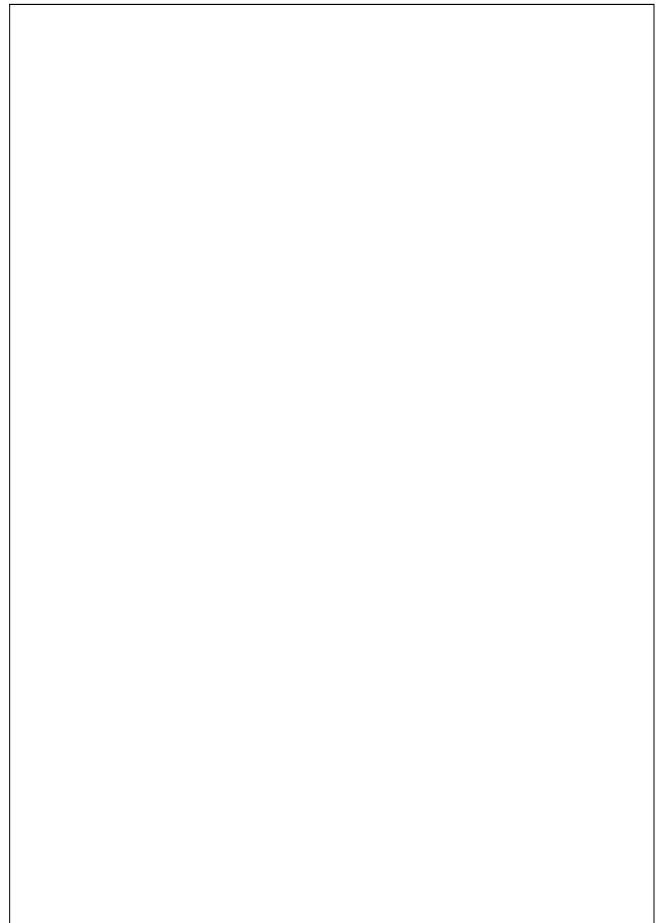
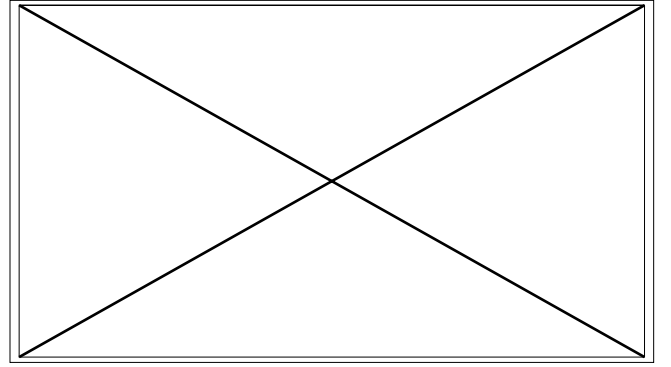

Scene	Duration	Panel	Duration
35	02:09	4	00:23

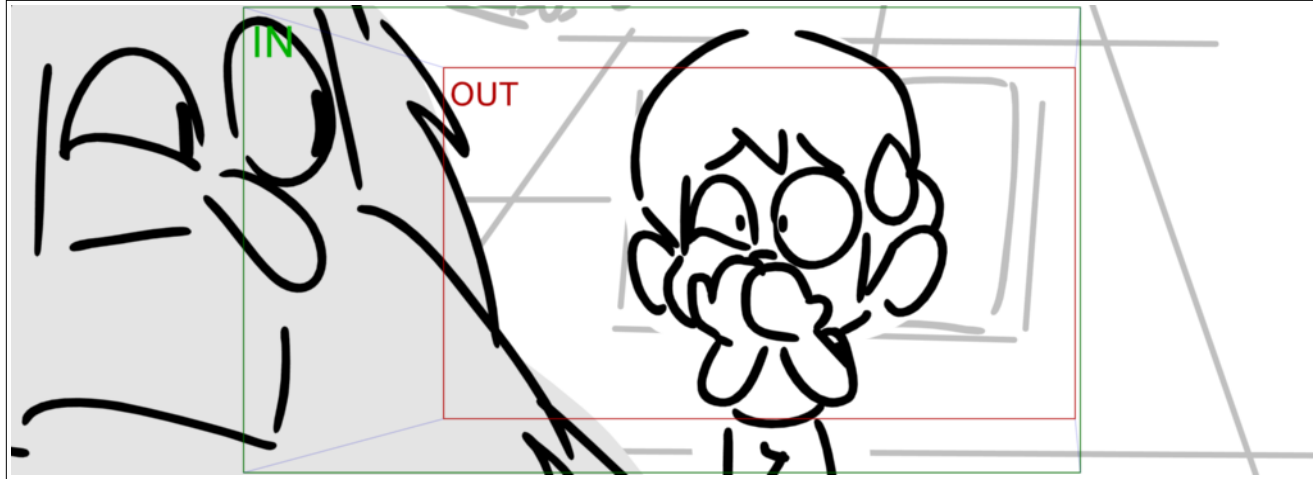

Scene	Duration	Panel	Duration
36	03:11	1	00:11

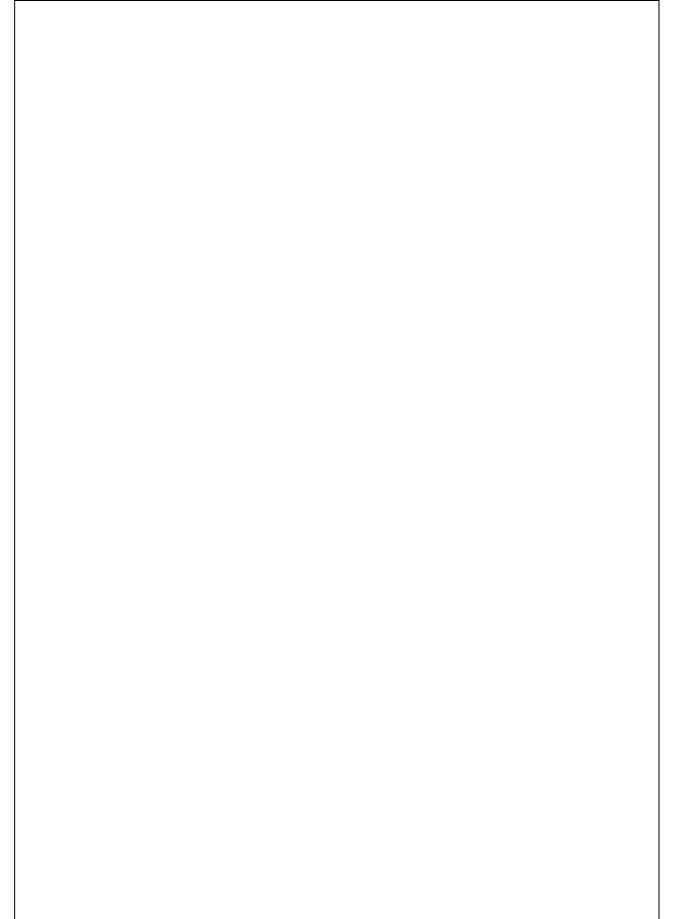

Scene	Duration	Panel	Duration
36	03:11	2	01:04

Scene	Duration	Panel	Duration
36	03:11	3	00:09

Scene	Duration	Panel	Duration
36	03:11	4	00:17



Dialogue
 19. GREGOR/VOIX DE TOM
 mais tu as mué ?!

Scene	Duration	Panel	Duration
36	03:11	5	00:20



Scene	Duration	Panel	Duration
37	01:13	1	01:13

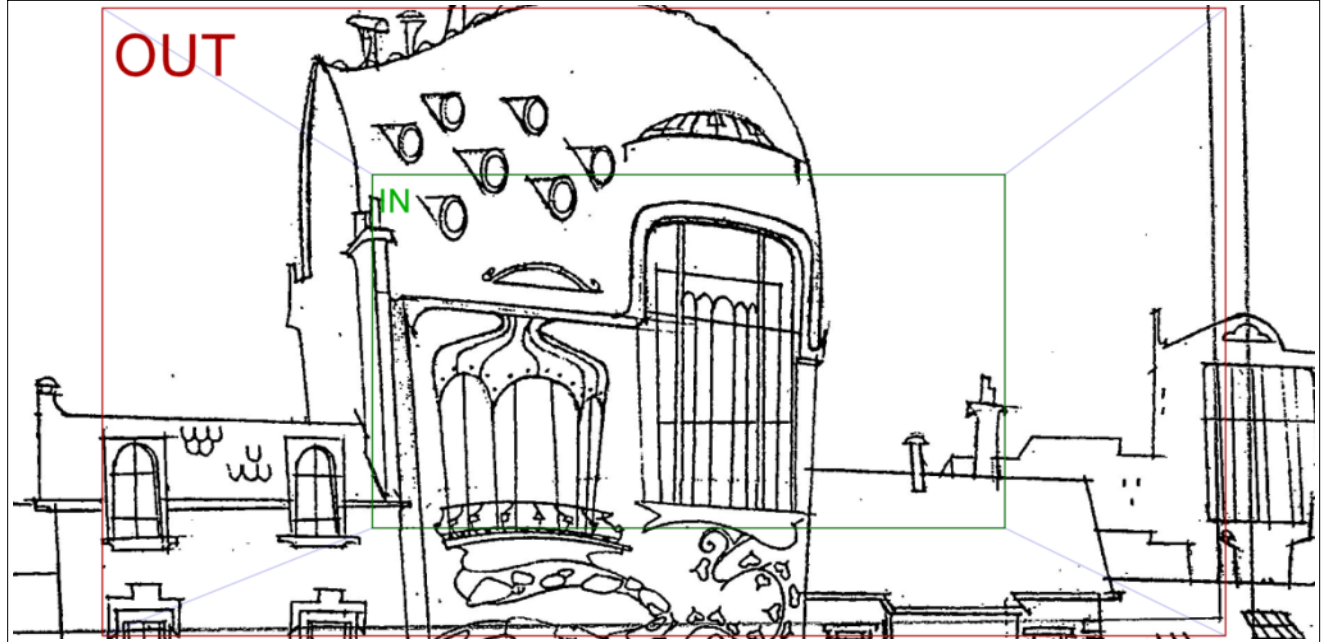

Dialogue

20. TOM ET GREGOR
 AHHHHHHHHHHHHHHH !!!

Scene	Duration	Panel	Duration
38	02:06	1	00:07

Scene	Duration	Panel	Duration
38	02:06	2	00:07

Scene	Duration	Panel	Duration
38	02:06	3	00:10

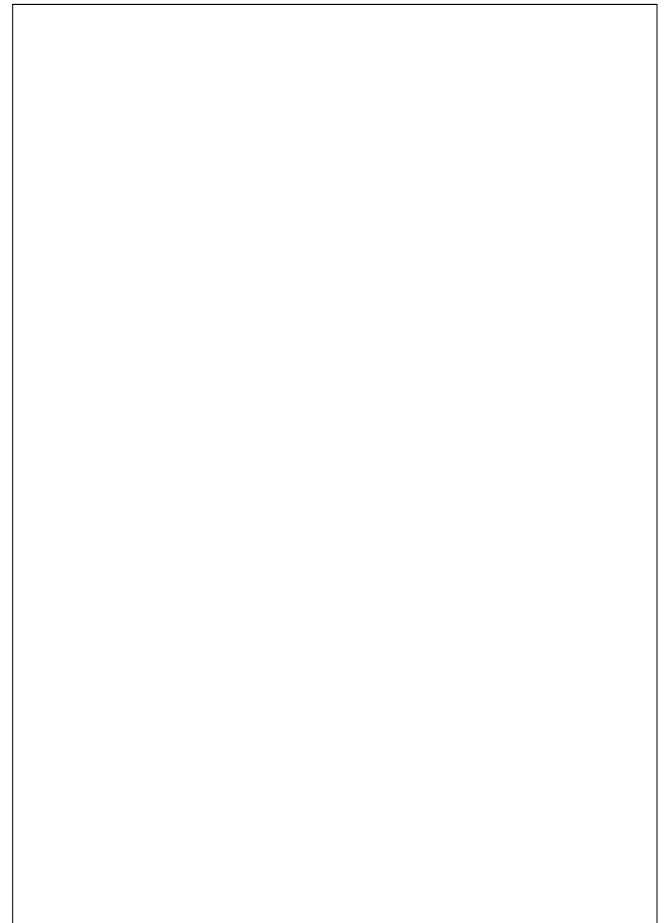
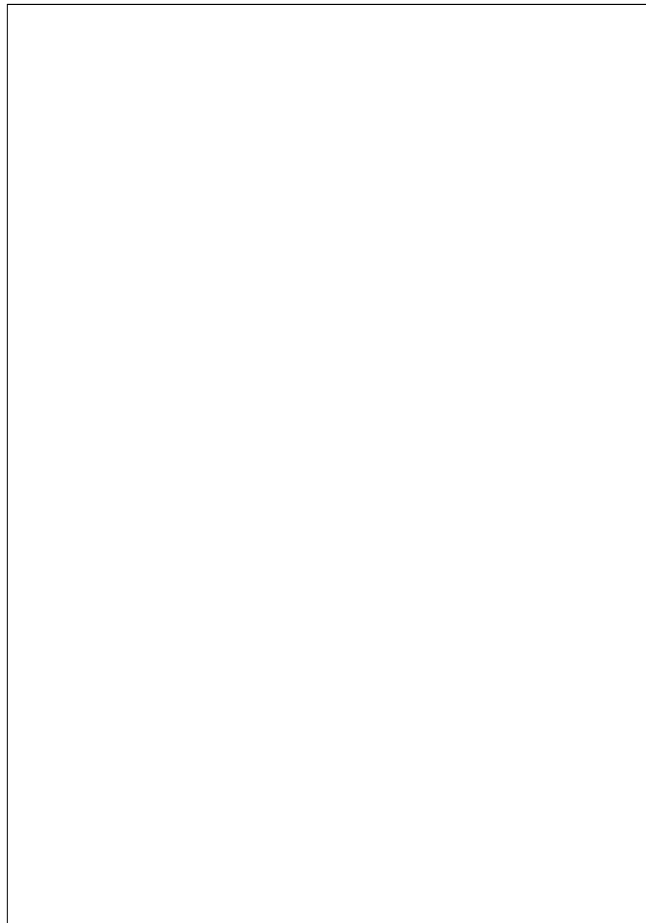
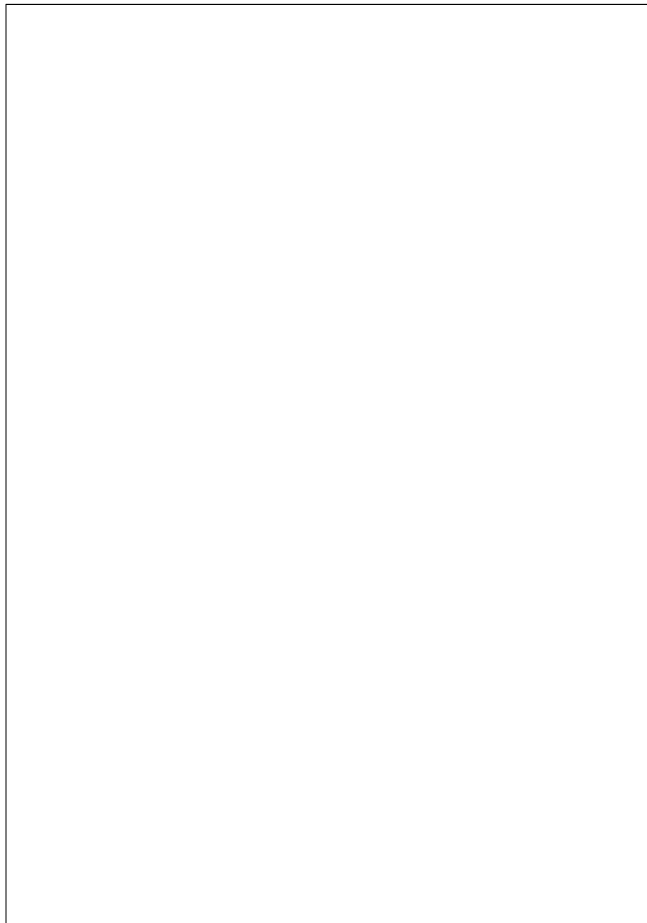
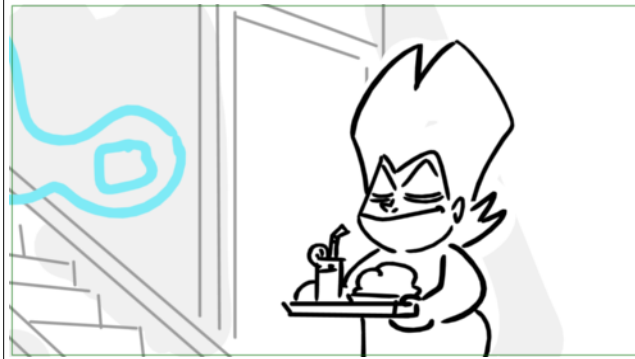

Scene	Duration	Panel	Duration
38	02:06	4	00:10



Scene	Duration	Panel	Duration
38	02:06	5	00:05

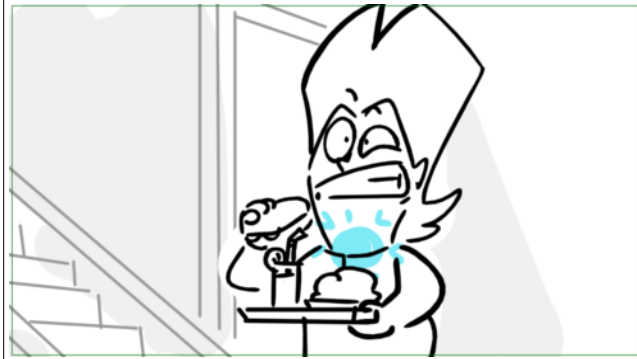

Dialogue
 22. FEROCIA
 HIC !

Scene	Duration	Panel	Duration
38	02:06	6	00:08

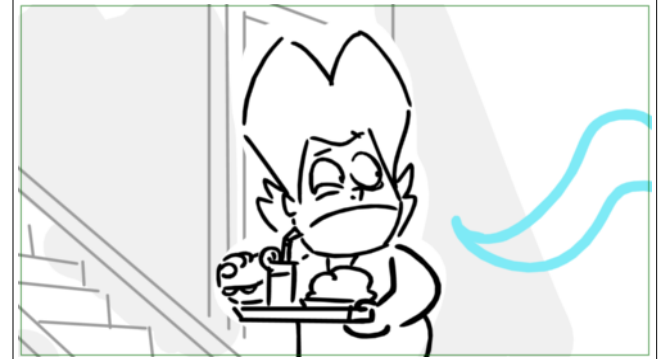

Scene	Duration	Panel	Duration
38	02:06	7	00:09



Scene	Duration	Panel	Duration
39	02:13	1	00:04



Scene	Duration	Panel	Duration
39	02:13	2	00:07



Scene	Duration	Panel	Duration
39	02:13	3	00:07

Scene	Duration	Panel	Duration
39	02:13	4	00:09

Scene	Duration	Panel	Duration
39	02:13	5	00:10

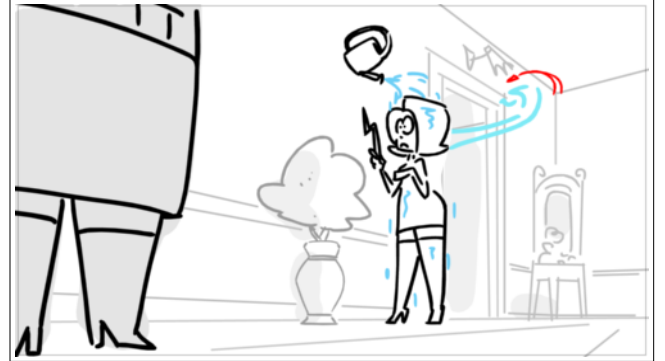

Dialogue

21. WILLOW
HIC !

Scene	Duration	Panel	Duration
39	02:13	6	00:13



Scene	Duration	Panel	Duration
39	02:13	7	00:13



Scene	Duration	Panel	Duration
40	01:00	1	00:08

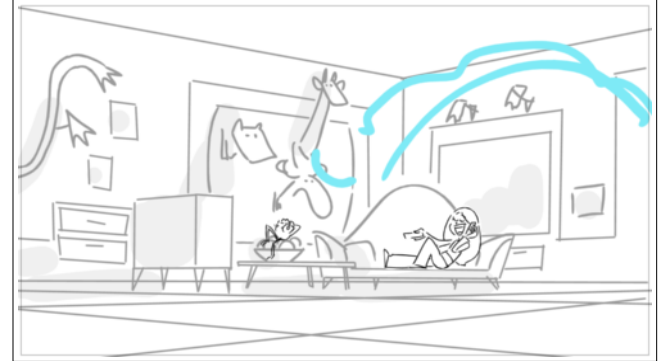

Dialogue

24. CINDY MODIF

Et là, je me suis pas laissée démonter,
tu vois!

Scene	Duration	Panel	Duration
40	01:00	2	00:09

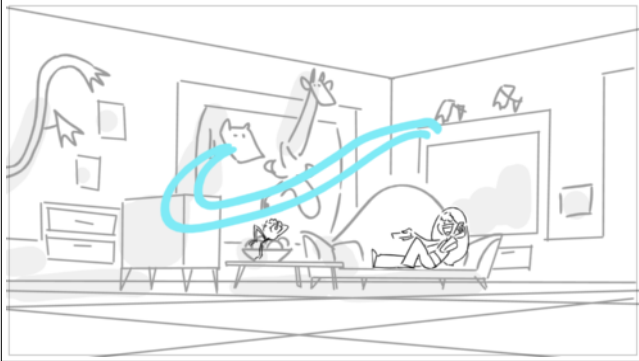

Dialogue

24. CINDY MODIF

Et là, je me suis pas laissée démonter,
tu vois!

Scene	Duration	Panel	Duration
40	01:00	3	00:08



Dialogue

24. CINDY MODIF

Et là, je me suis pas laissée démonter,
tu vois!

Scene	Duration	Panel	Duration
41	01:22	1	00:09



Dialogue

24. CINDY

je lui ai dis : eh ho non mais allo
quoi!

Scene	Duration	Panel	Duration
41	01:22	2	00:18



Dialogue
 24. CINDY
 je lui ai dis : eh ho non mais allo
 quoi!

Scene	Duration	Panel	Duration
41	01:22	3	00:07



Dialogue
 23. Monseigneur
 Hic !

Scene	Duration	Panel	Duration
41	01:22	4	00:09



Scene	Duration	Panel	Duration
41	01:22	5	00:04



Scene	Duration	Panel	Duration
42	05:20	1	00:08



Dialogue
 24. CINDY
 en matière de féminité, l'experte
 ici...

Scene	Duration	Panel	Duration
42	05:20	2	00:08

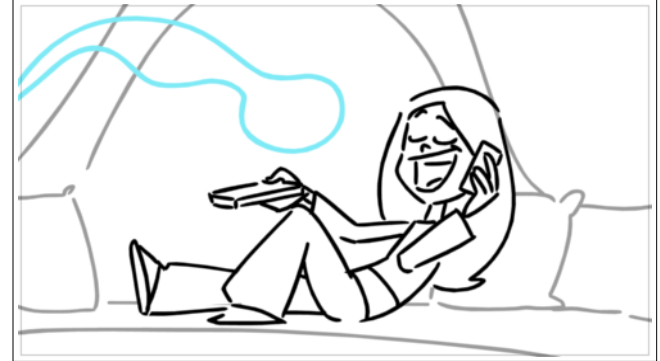

Dialogue
 24. CINDY
 en matière de féminité, l'experte
 ici...

Scene	Duration	Panel	Duration
42	05:20	3	00:11

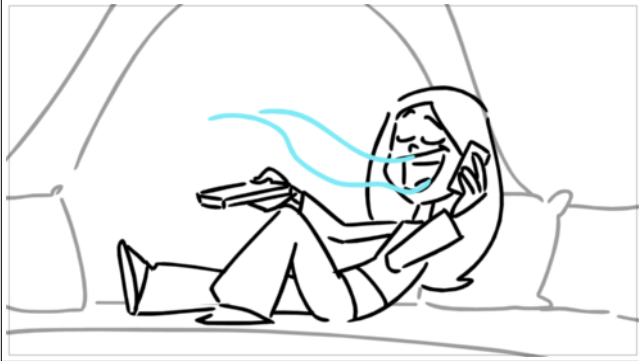

Dialogue
 24. CINDY
 en matière de féminité, l'experte
 ici...

Scene	Duration	Panel	Duration
42	05:20	4	00:10

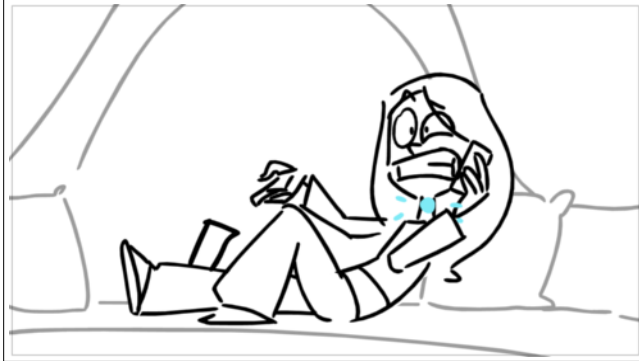

Dialogue
 24. CINDY
 HIC !

Scene	Duration	Panel	Duration
42	05:20	5	01:12

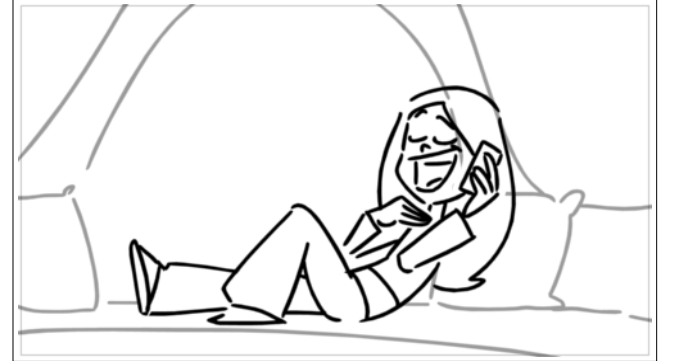

Dialogue
 25. CINDY/VOIX DE MONSEIGNEUR
 c'est moi tu vois!...

Scene	Duration	Panel	Duration
42	05:20	6	00:13

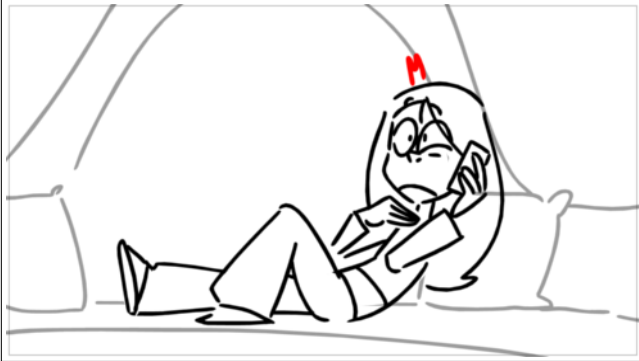

Scene	Duration	Panel	Duration
42	05:20	7	00:07

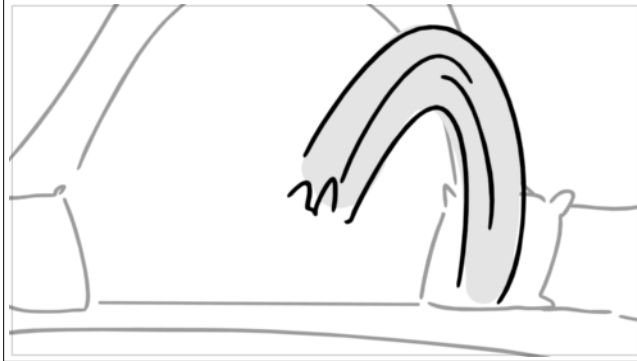

Dialogue
SFX BIP!

Scene	Duration	Panel	Duration
42	05:20	8	00:07



Dialogue
SFX BIP!

Scene	Duration	Panel	Duration
42	05:20	9	01:19



Dialogue

26. MONSEIGNEUR/voix de Cindy
Euh Cin... dy...

Scene	Duration	Panel	Duration
43	03:20	1	01:21



Dialogue

26. MONSEIGNEUR/voix de Cindy
tu... parles... avec...

Scene	Duration	Panel	Duration
43	03:20	2	01:12

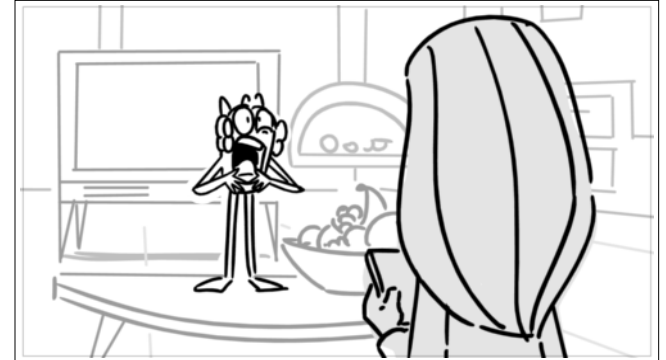

Dialogue

26. MONSEIGNEUR/voix de Cindy
tu... parles... avec...

Scene	Duration	Panel	Duration
43	03:20	3	00:12

Scene	Duration	Panel	Duration
44	01:04	1	00:05

Scene	Duration	Panel	Duration
44	01:04	2	00:24

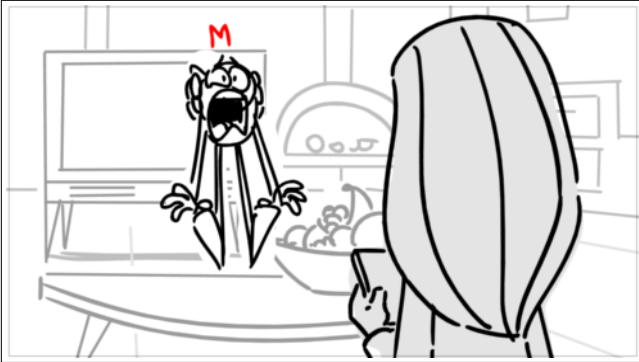

Dialogue
 26. MONSEIGNEUR/voix de Cindy
 MA VOIX !?!

Scene	Duration	Panel	Duration
45	01:19	1	01:19

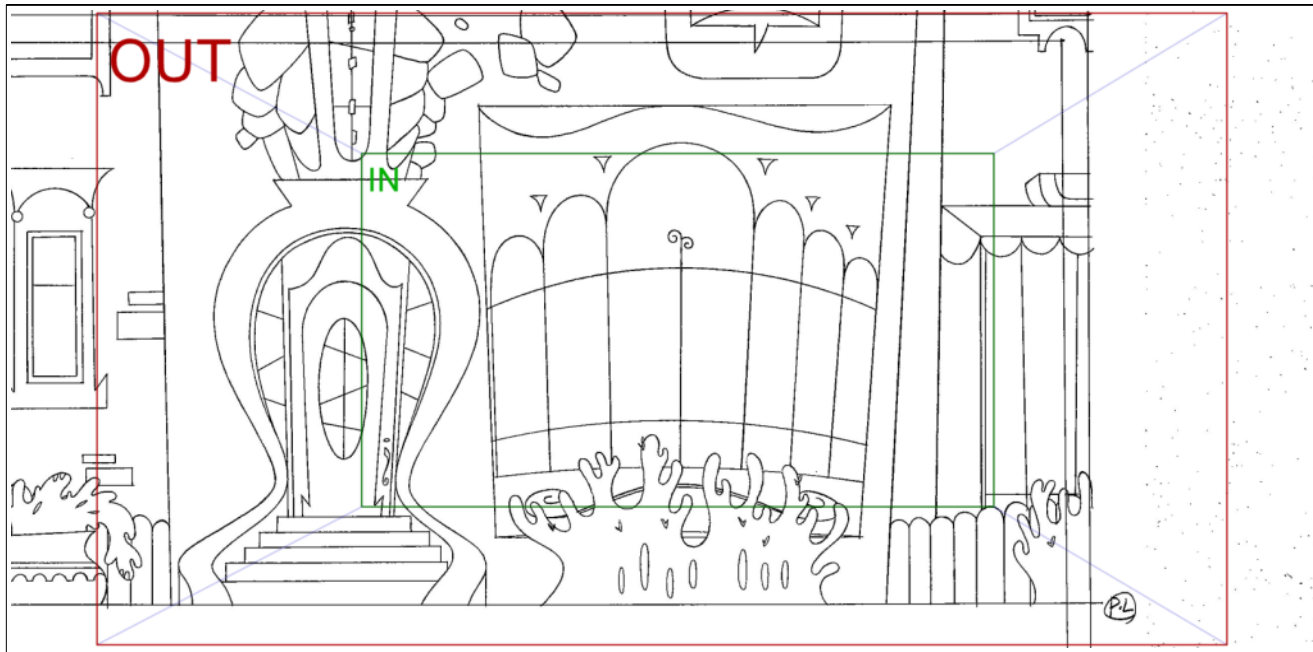

Dialogue

27. CINDy/VOIX DE MONSEIGNEUR
 ... NOOOoooooon !

Scene	Duration	Panel	Duration
46	03:14	1	03:14



Dialogue

29. GREGOR/VOIX DE TOM
 ...à ton âge, faire une telle bêtise !!

Action Notes

6. INT. MAISON FEERICKSEN - S ALON - JOUR

Scene	Duration	Panel	Duration
47	01:20	1	00:18



Dialogue
 30. TOM/VOIX de grégor
 Pardon mon papounet.

Scene	Duration	Panel	Duration
47	01:20	2	01:02



Dialogue
 30. TOM/VOIX de grégor
 Pardon mon papounet.

Scene	Duration	Panel	Duration
48	20:13	1	00:05



Scene	Duration	Panel	Duration
48	20:13	2	01:06



Dialogue

28. Monseigneur/voix Cindy
D'abord mon corps,

Scene	Duration	Panel	Duration
48	20:13	3	01:04



Dialogue

28. Monseigneur/voix Cindy
D'abord mon corps, maintenant ma voix.

Scene	Duration	Panel	Duration
48	20:13	4	01:11



Dialogue

28. Monseigneur/voix Cindy
On ne m'aura rien laissé !

Scene	Duration	Panel	Duration
48	20:13	5	01:16



Dialogue

31. FEROCIA/VOIX DE WILLOW MODIF
(mélodieuse)
Et moi alors!

Scene	Duration	Panel	Duration
48	20:13	6	02:05



Dialogue

31. FEROCIA/VOIX DE WILLOW MODIF
(mélodieuse)
on dirait que j'ai avalé un rossignol!

Scene	Duration	Panel	Duration
48	20:13	7	00:12

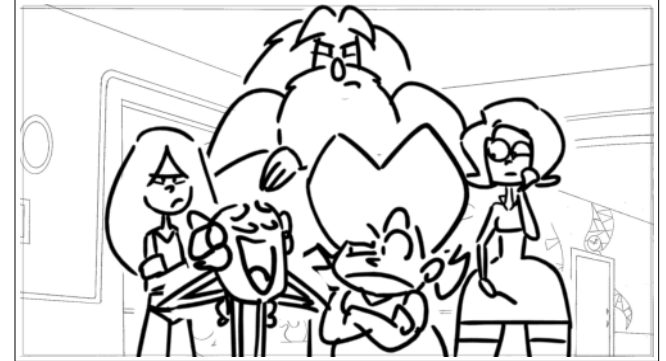

Scene	Duration	Panel	Duration
48	20:13	8	01:00

Scene	Duration	Panel	Duration
48	20:13	9	01:00

Scene	Duration	Panel	Duration
48	20:13	10	01:00

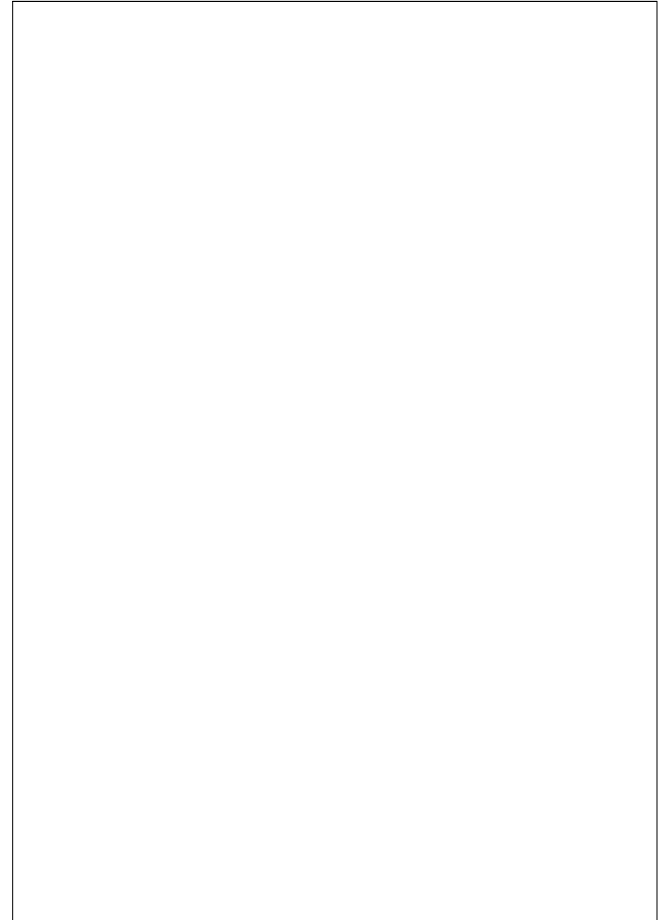
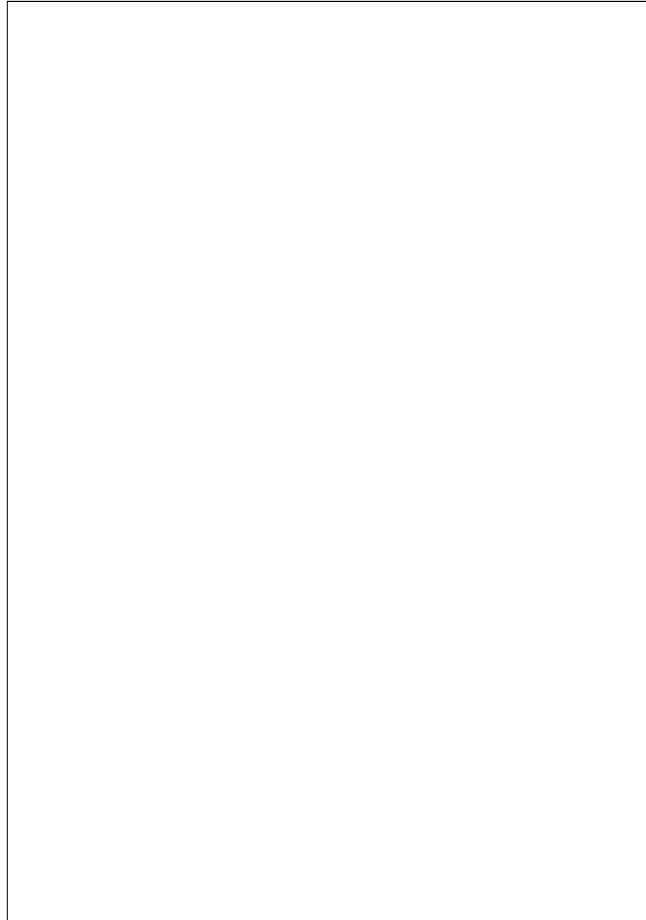
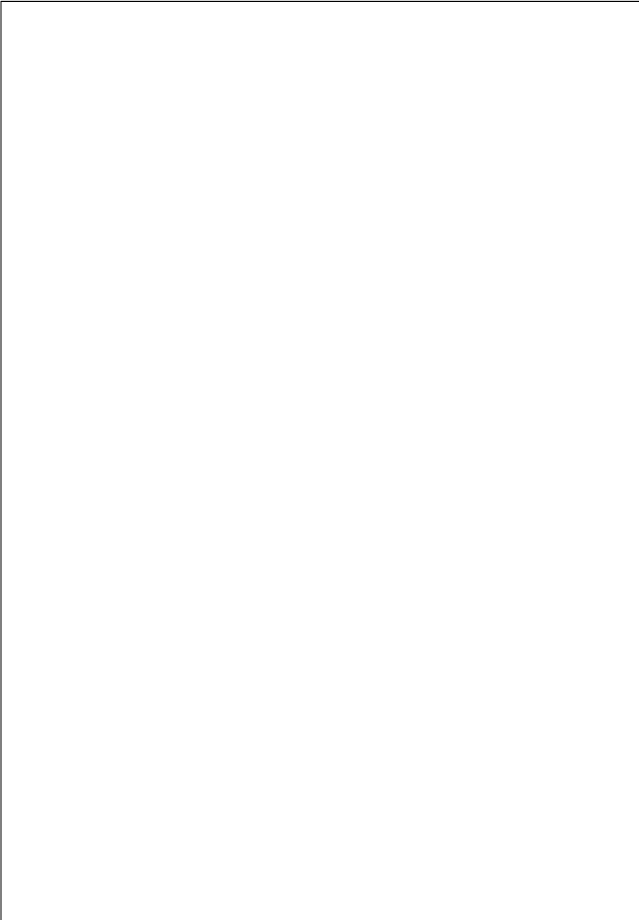

Scene	Duration	Panel	Duration
48	20:13	11	01:04



Scene	Duration	Panel	Duration
48	20:13	12	01:02



Scene	Duration	Panel	Duration
48	20:13	13	00:18

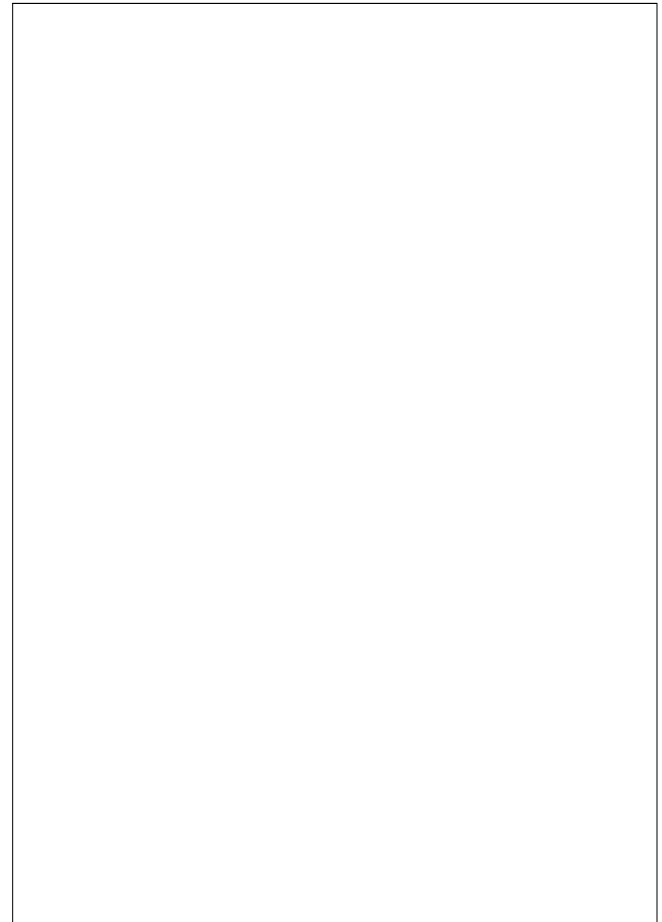
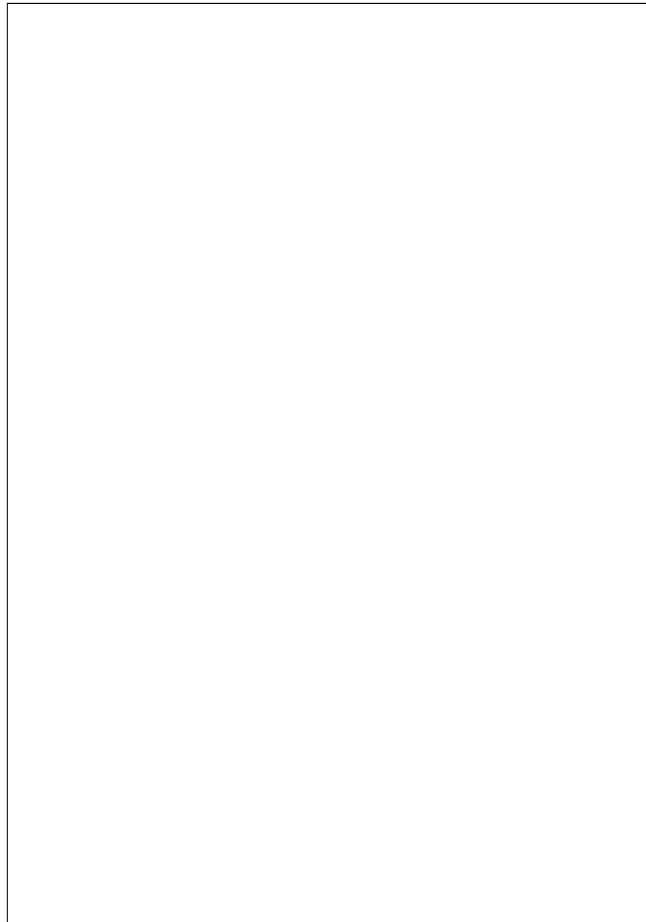
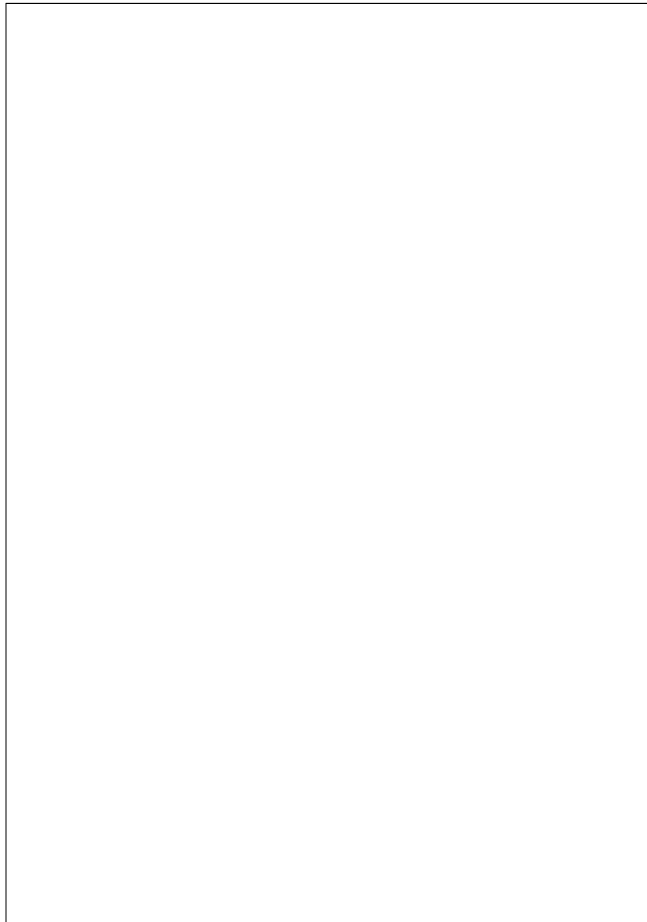

Scene	Duration	Panel	Duration
48	20:13	14	02:15



Scene	Duration	Panel	Duration
48	20:13	15	00:20

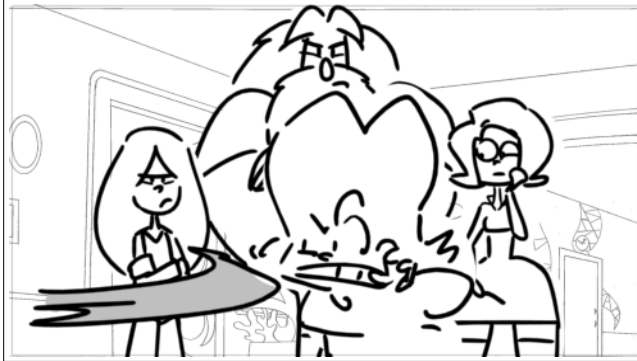

Scene	Duration	Panel	Duration
48	20:13	16	00:22

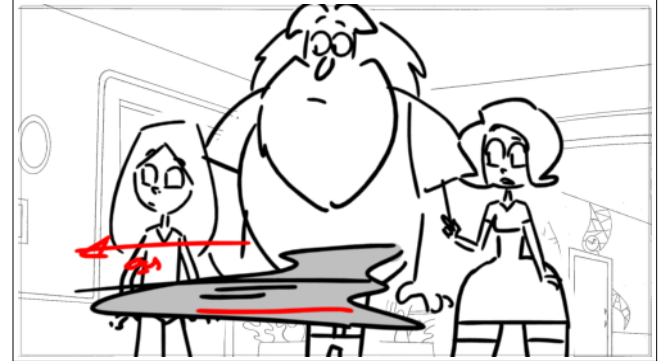

Scene	Duration	Panel	Duration
48	20:13	17	01:23

Scene	Duration	Panel	Duration
49	06:13	1	00:13

NO PANEL

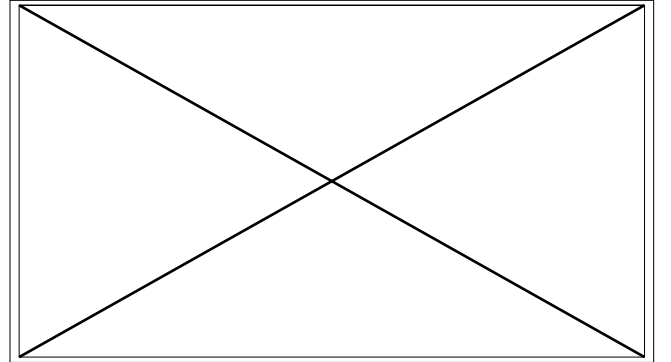

Dialogue
 33. WILLOW/voix de Ferocia
 Allez mes petits chéris!

Dialogue
 33. WILLOW/voix de Ferocia
 On ne va pas se fâcher pour si peu.

(Empty space for dialogue or notes)

Scene	Duration	Panel	Duration
49	06:13	2	02:00

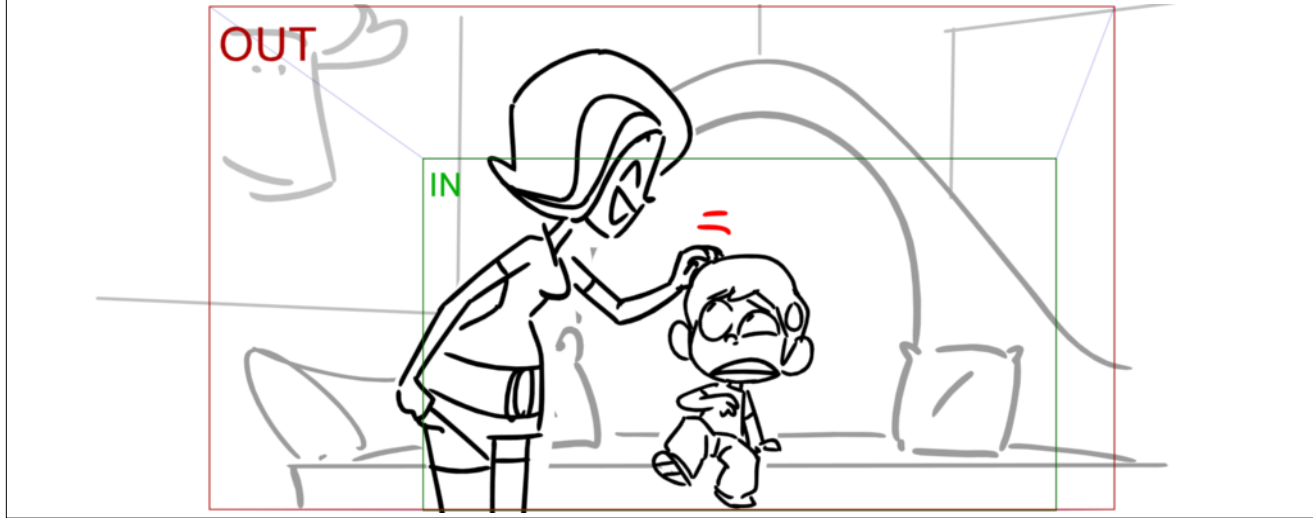

Dialogue
 33. WILLOW/voix de Ferocia
 Je vais inverser la formule

Scene	Duration	Panel	Duration
49	06:13	3	01:15

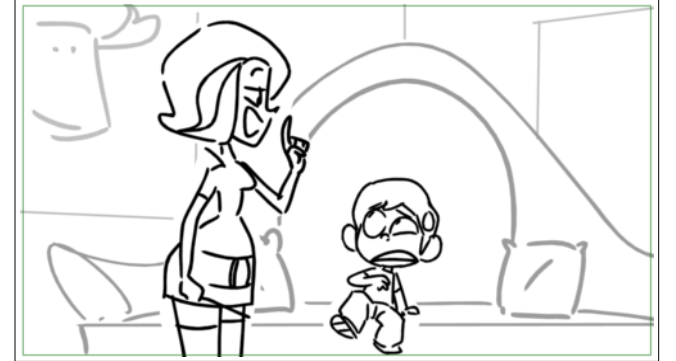

Dialogue
 33. WILLOW/voix de Ferocia
 Je vais inverser la formule

Scene	Duration	Panel	Duration
49	06:13	4	02:10



Dialogue

33. WILLOW/voix de Ferocia
et tout va rentrer dans l'ordre.

Scene	Duration	Panel	Duration
50	02:17	1	00:17

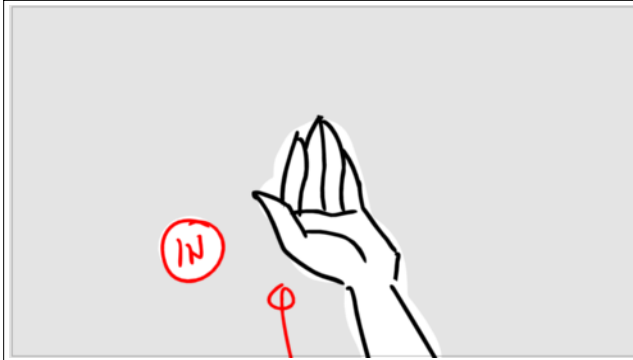

Action Notes

Main de Willow IN

Scene	Duration	Panel	Duration
50	02:17	2	01:00

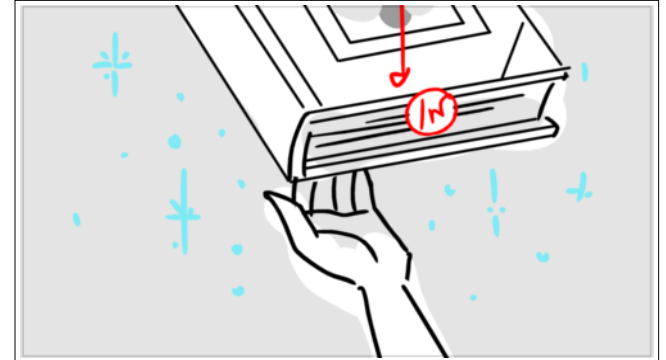

Action Notes

Grimoire IN +fx



Scene	Duration	Panel	Duration
50	02:17	3	01:00



Scene	Duration	Panel	Duration
51	03:01	1	01:03

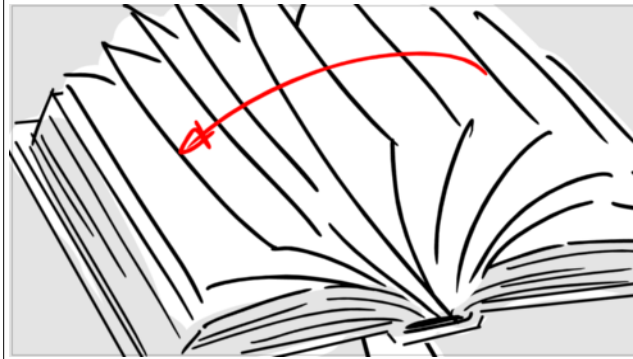

Scene	Duration	Panel	Duration
51	03:01	2	00:11

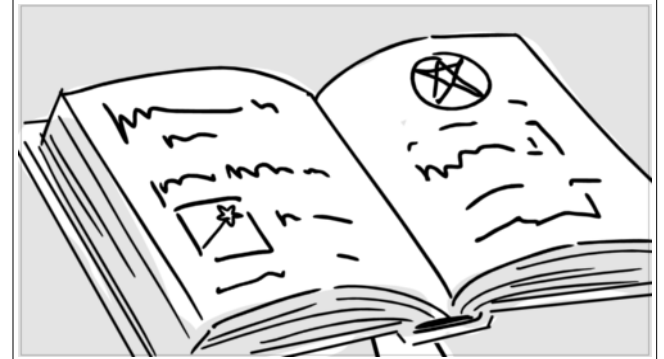

Action Notes

Les pages tournent toutes seules

Dialogue

34. Willow/voix de Ferocia (suite)
« Motus et bouche dé cousue,

Scene	Duration	Panel	Duration
51	03:01	3	01:12

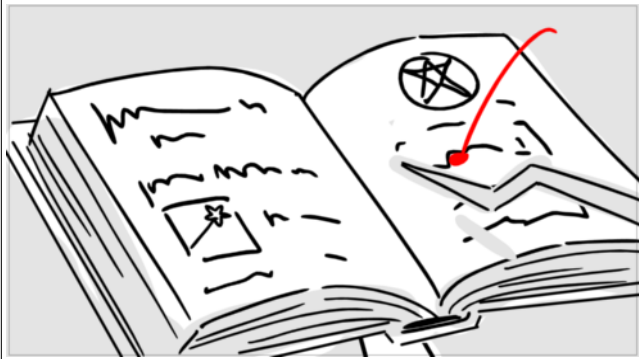

Dialogue

34. Willow/voix de Ferocia (suite)
« Motus et bouche décousue,

Action Notes

baguette IN

Scene	Duration	Panel	Duration
52	04:09	1	00:23



Dialogue

34. Willow/voix de Ferocia (suite)
que nos voix

Scene	Duration	Panel	Duration
52	04:09	2	01:18



Dialogue

34. Willow/voix de Ferocia (suite)
que nos voix

Scene	Duration	Panel	Duration
52	04:09	3	00:13



Dialogue
34. Willow/voix de Ferocia (suite)
que nos voix

Scene	Duration	Panel	Duration
52	04:09	4	01:05



Dialogue
34. Willow/voix de Ferocia (suite)
que nos voix

Scene	Duration	Panel	Duration
53	02:19	1	02:19



Dialogue
34. Willow/voix de Ferocia (suite)
que nos voix

Scene	Duration	Panel	Duration
54	07:12	1	00:18



Dialogue

34. Willow/voix de Ferocia (suite)
que nos voix

Scene	Duration	Panel	Duration
54	07:12	2	01:00



Dialogue

34. Willow/voix de Ferocia (suite)
que nos voix

Scene	Duration	Panel	Duration
54	07:12	3	02:18



Dialogue

34. Willow/voix de Ferocia (suite)
que nos voix

Scene	Duration	Panel	Duration
54	07:12	4	00:21

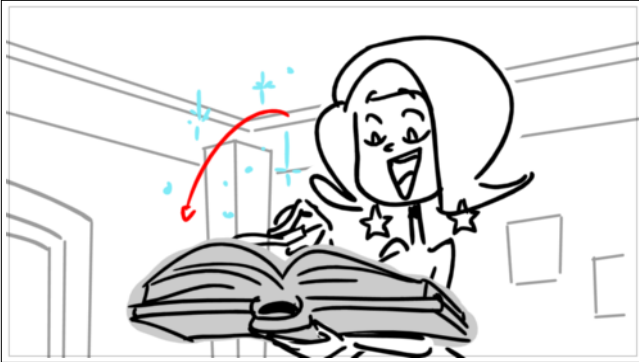

Dialogue
 34. Willow/voix de Ferocia (suite)
 que nos voix

Scene	Duration	Panel	Duration
54	07:12	5	02:05



Dialogue
 34. Willow/voix de Ferocia (suite)
 que nos voix

Scene	Duration	Panel	Duration
55	01:14	1	01:14

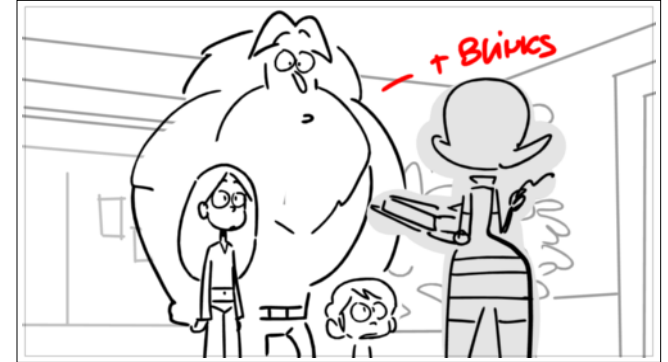



Scene	Duration	Panel	Duration
56	07:21	1	01:00



Scene	Duration	Panel	Duration
56	07:21	2	01:02



Scene	Duration	Panel	Duration
56	07:21	3	00:15



Scene	Duration	Panel	Duration
56	07:21	4	00:16

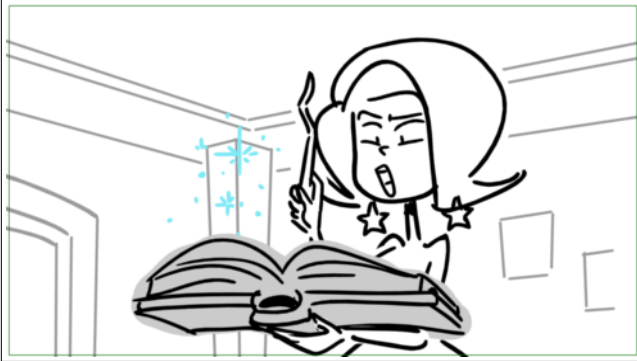

Scene	Duration	Panel	Duration
56	07:21	5	00:14



Dialogue

34. Willow/voix de Ferocia (suite)(en s'énervant)
ré-échantent ! !!

Scene	Duration	Panel	Duration
56	07:21	6	01:13

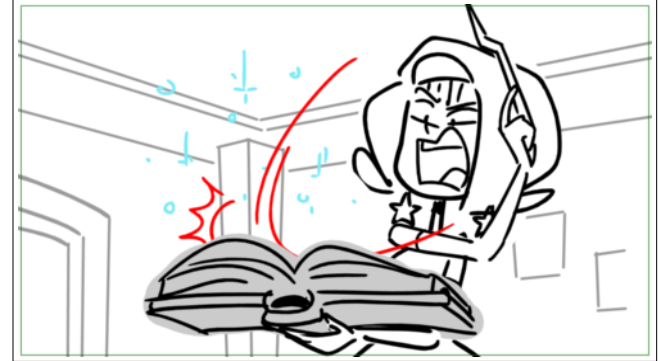

Dialogue

34. Willow/voix de Ferocia (suite)(en s'énervant)
ré-échantent ! !!

Scene	Duration	Panel	Duration
56	07:21	7	01:09



Scene	Duration	Panel	Duration
56	07:21	8	01:02



Dialogue

PU WILLOW voix de FEROCIA



Scene	Duration	Panel	Duration
57	02:00	1	01:00

Scene	Duration	Panel	Duration
57	02:00	2	01:00

Scene	Duration	Panel	Duration
58	02:15	1	00:06

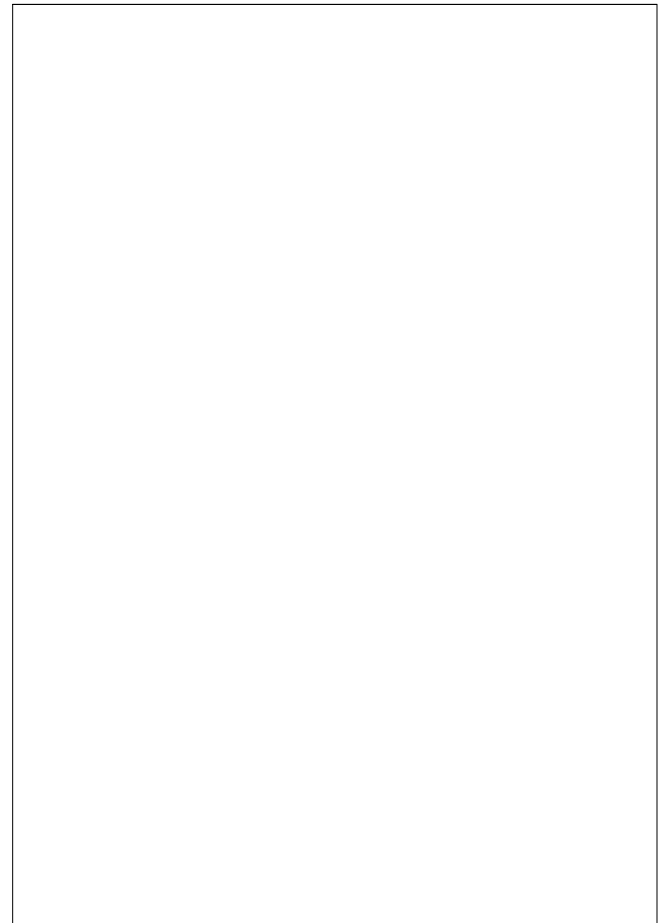
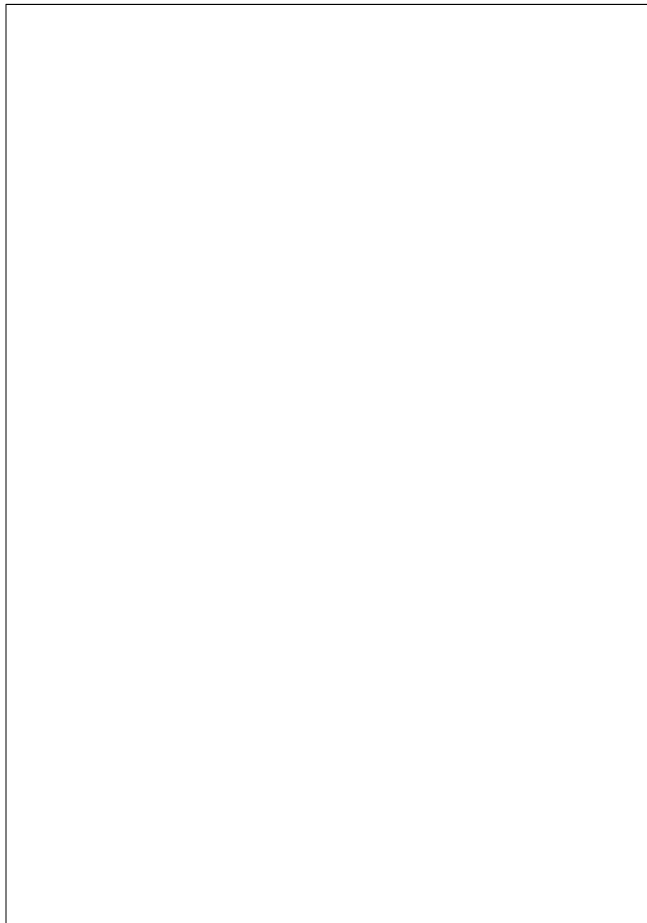
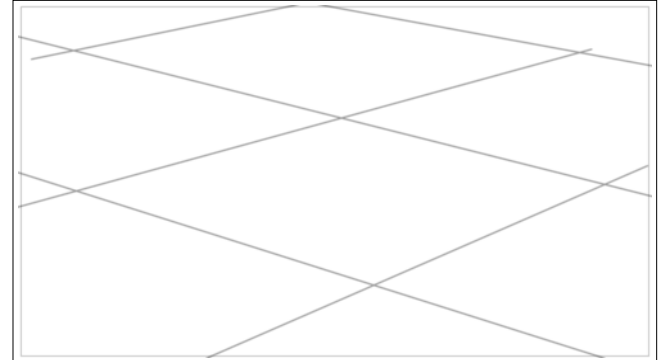

Scene	Duration	Panel	Duration
58	02:15	2	00:14

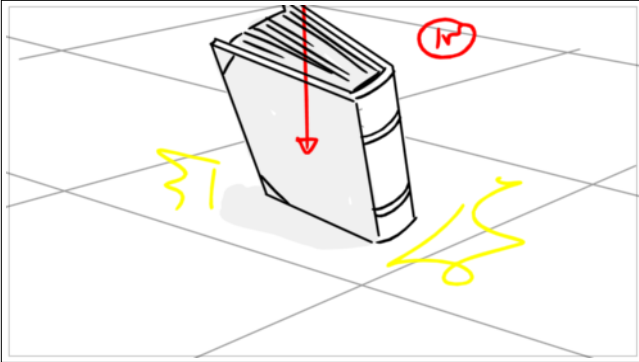

Scene	Duration	Panel	Duration
58	02:15	3	00:15

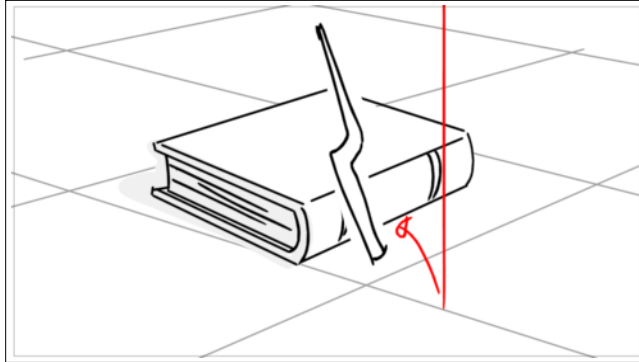

Scene	Duration	Panel	Duration
58	02:15	4	01:05

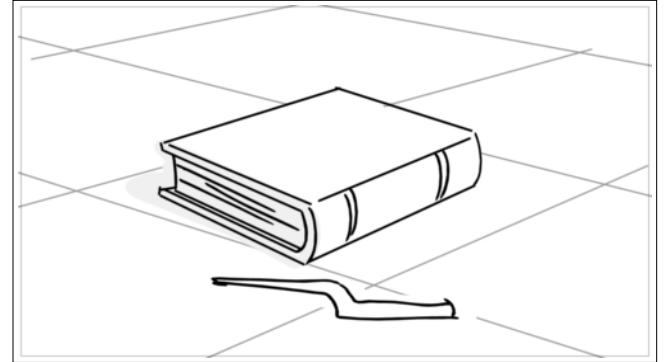

Dialogue

35. WILLOW/Voix de FEROCIA MODIF
J'abandonne!

Dialogue

35. WILLOW/Voix de FEROCIA MODIF
J'abandonne!

Scene	Duration	Panel	Duration
59	06:17	1	00:08



Scene	Duration	Panel	Duration
59	06:17	2	00:11



Scene	Duration	Panel	Duration
59	06:17	3	01:10



Dialogue

35. WILLOW/Voix de FEROCIA MODIF
 En attendant que je trouve une solution

Scene	Duration	Panel	Duration
59	06:17	4	01:16

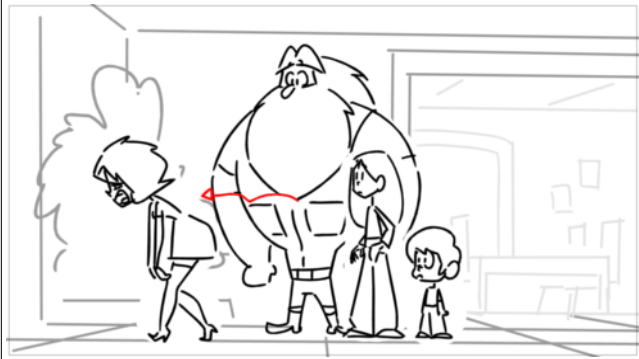

Dialogue
 35. WILLOW/Voix de FEROCIA MODIF
 on va devoir faire avec!

Scene	Duration	Panel	Duration
59	06:17	5	00:22

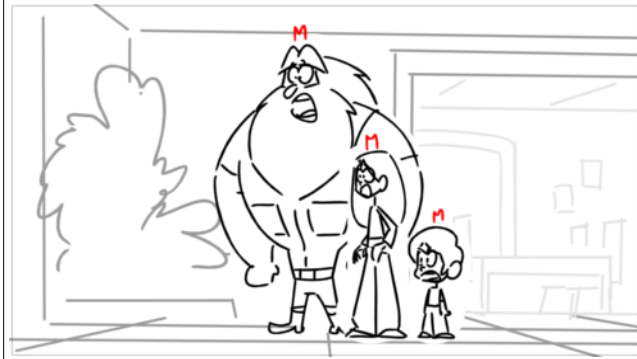

Dialogue
 TOUS
 Hein?

Scene	Duration	Panel	Duration
59	06:17	6	01:00



Scene	Duration	Panel	Duration
59	06:17	7	01:00



Scene	Duration	Panel	Duration
60	01:09	1	00:12



Dialogue
TOM
Hmrrrrr !

Scene	Duration	Panel	Duration
60	01:09	2	00:22



Dialogue
TOM
Hmrrrrr !



Scene	Duration	Panel	Duration
61	01:00	1	01:00



Scene	Duration	Panel	Duration
62	01:11	1	00:11



Action Notes

8. INT. ECOLE COULOIR - JOUR



Scene	Duration	Panel	Duration
62	01:11	2	01:00



Scene	Duration	Panel	Duration
63	01:13	1	00:13



Scene	Duration	Panel	Duration
63	01:13	2	00:12



Scene	Duration	Panel	Duration
63	01:13	3	00:13



Action Notes

Tom fait un clin d'oeil à Jojo

Scene	Duration	Panel	Duration
64	04:02	1	01:00



Action Notes

PAN BG

Scene	Duration	Panel	Duration
64	04:02	2	03:02



Dialogue

36. JOJO

A maîtriser la force apprendre tu dois...

Action Notes

Stop pan BG

Scene	Duration	Panel	Duration
65	04:22	1	01:24



Dialogue

37. Tom/VOIX de grégor
Silence Maître Yoga

Scene	Duration	Panel	Duration
65	04:22	2	02:23

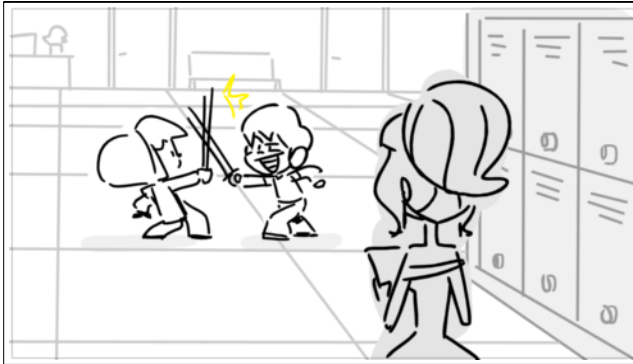

Dialogue

37. Tom/VOIX de grégor
voici la réponse de mon sabre laser !

Scene	Duration	Panel	Duration
66	02:24	1	00:14





Scene	Duration	Panel	Duration
66	02:24	2	00:05

Scene	Duration	Panel	Duration
66	02:24	3	00:11

Scene	Duration	Panel	Duration
66	02:24	4	01:19



Action Notes

BLINK

Dialogue

38. Mlle Fossette
Bravo ! Bravo !

Scene	Duration	Panel	Duration
67	06:20	1	00:11



Scene	Duration	Panel	Duration
67	06:20	2	00:14



Dialogue

38. Mlle Fossette
Quelle voix Tom!

Scene	Duration	Panel	Duration
67	06:20	3	01:12



Dialogue

38. Mlle Fossette
je suis impressionnée !

Scene	Duration	Panel	Duration
67	06:20	4	02:15

Scene	Duration	Panel	Duration
67	06:20	5	01:18

Scene	Duration	Panel	Duration
68	01:03	1	00:07



Dialogue

39. Tom/voix de Gregor
Euh oui, c'est parce que... euh,

Dialogue

39. Tom/voix de Gregor
j'ai mué dans la nuit...

Scene	Duration	Panel	Duration
68	01:03	2	00:21



Action Notes

sourcil se lève

Scene	Duration	Panel	Duration
69	02:21	1	01:06

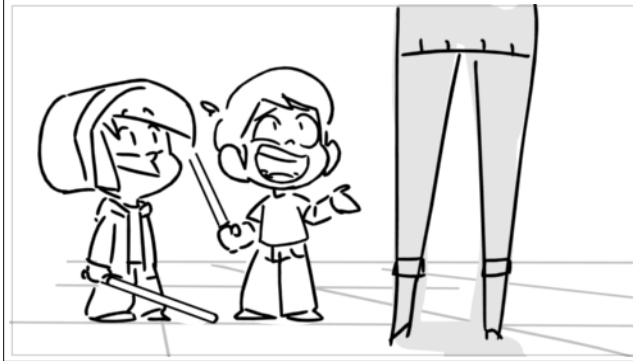

Dialogue

39. Tom/voix de Gregor
c'est un truc de... euh...

Scene	Duration	Panel	Duration
69	02:21	2	01:15

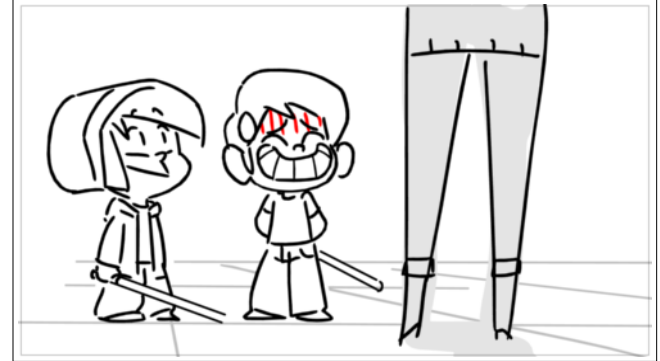

Dialogue

39. Tom/voix de Gregor
de famille !

Scene	Duration	Panel	Duration
70	01:10	1	00:14



Scene	Duration	Panel	Duration
70	01:10	2	00:21

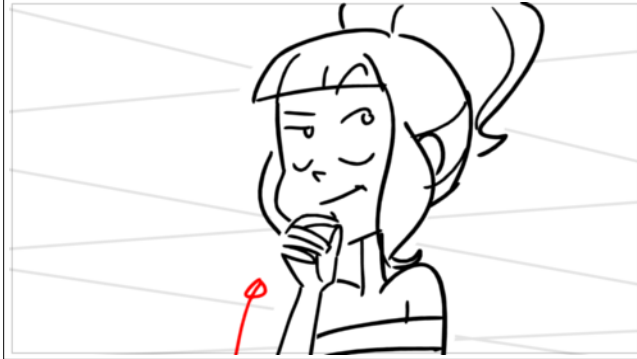

Scene	Duration	Panel	Duration
71	03:11	1	03:11



Dialogue

40. Mlle Fossette
 Les enfants, j'ai décidé de revoir un peu la répartition des rôles.

Action Notes

9. INT. SALLE DE CLASSE - JOUR

Scene	Duration	Panel	Duration
72	01:17	1	00:12



Dialogue
40. Mlle Fossette
Jojo

Scene	Duration	Panel	Duration
72	01:17	2	00:15

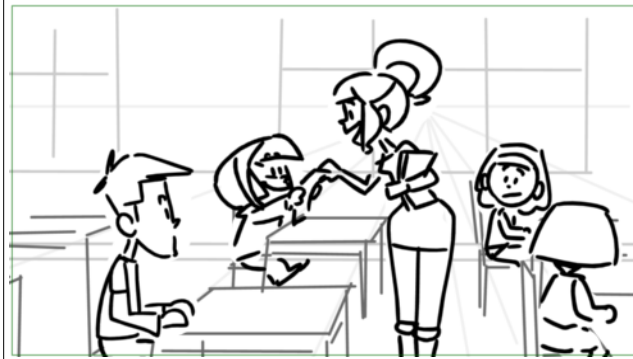

Dialogue
40. Mlle Fossette
tu seras Maître Yoga.

Scene	Duration	Panel	Duration
72	01:17	3	00:15

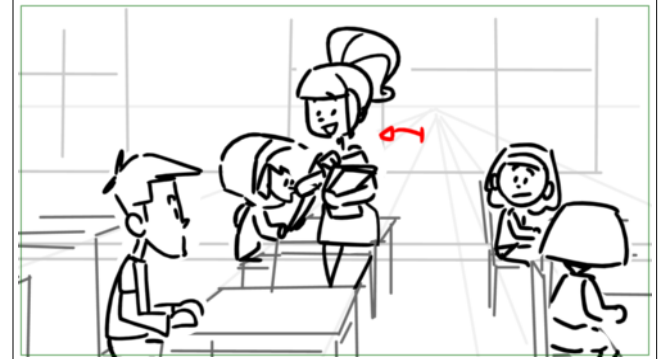

Dialogue
40. Mlle Fossette
Quant à toi, Tom,

Scene	Duration	Panel	Duration
73	03:21	1	00:16



Dialogue
 40. Mlle Fossette
 Victor,

Scene	Duration	Panel	Duration
73	03:21	2	00:11

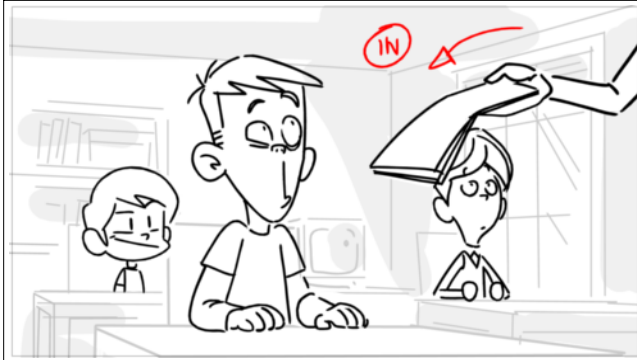

Dialogue
 40. Mlle Fossette
 je te confie le rôle de Choubaba

Scene	Duration	Panel	Duration
73	03:21	3	01:05



Scene	Duration	Panel	Duration
73	03:21	4	00:11



Scene	Duration	Panel	Duration
73	03:21	5	01:03



Scene	Duration	Panel	Duration
74	03:01	1	00:14



Dialogue

40. Mlle Fossette
Quant à toi, Tom,

Scene	Duration	Panel	Duration
74	03:01	2	00:23

Scene	Duration	Panel	Duration
74	03:01	3	00:22

NO PANEL

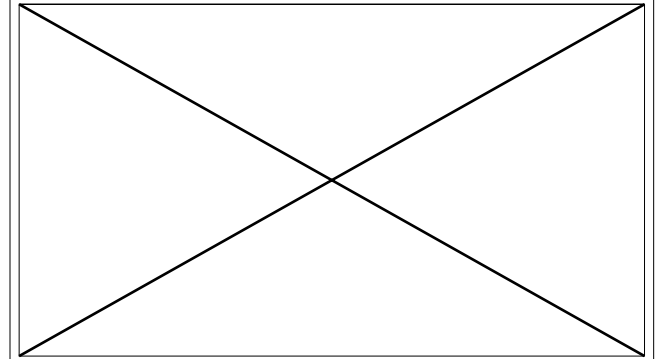
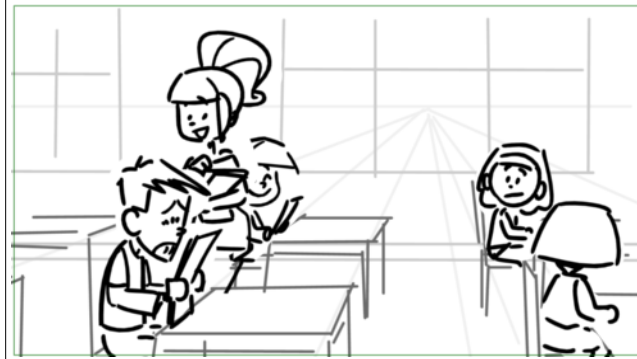
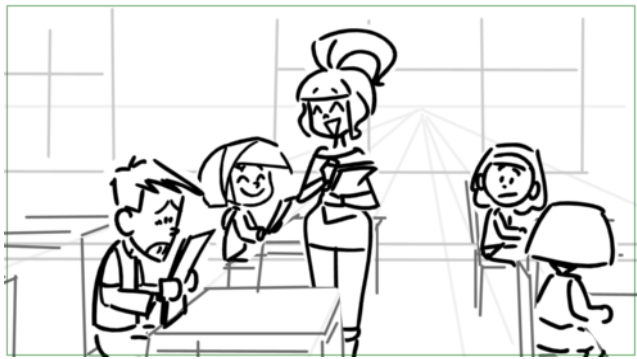

Dialogue
 40. Mlle Fossette
 Quant à toi, Tom,

Dialogue
 40. Mlle Fossette
 Quant à toi, Tom,

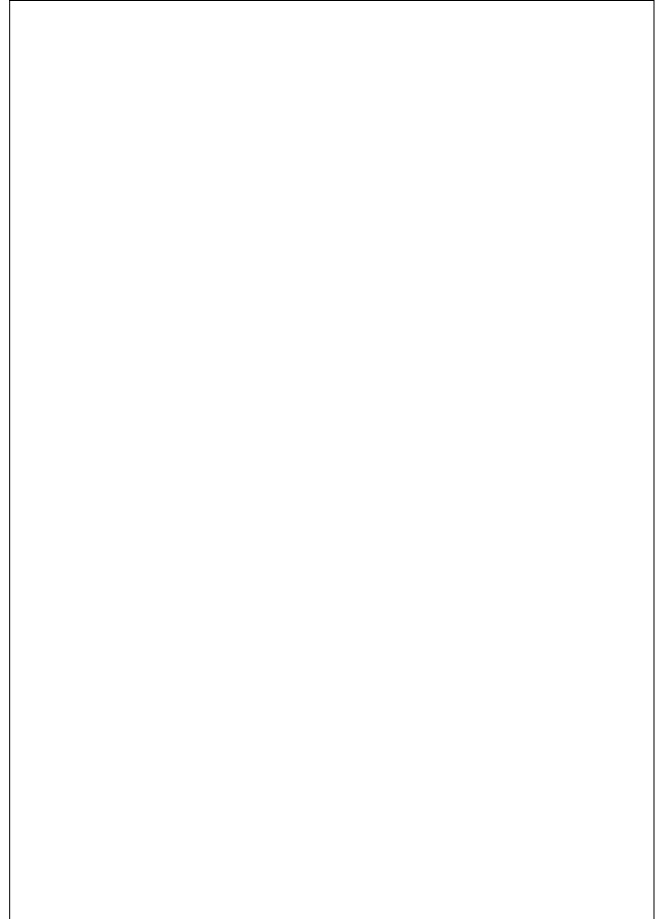

Scene	Duration	Panel	Duration
74	03:01	4	00:17



Dialogue
 40. Mlle Fossette
 Quant à toi, Tom,

Scene	Duration	Panel	Duration
75	05:02	1	00:14



Dialogue
 40. Mlle Fossette
 le rôle de Dark Vapor t'est tout désigné !

Scene	Duration	Panel	Duration
75	05:02	2	00:18



Dialogue

40. Mlle Fossette
le rôle de Dark Vapor t'est tout désigné !

Scene	Duration	Panel	Duration
75	05:02	3	01:20



Dialogue

40. Mlle Fossette
le rôle de Dark Vapor t'est tout désigné !

Scene	Duration	Panel	Duration
75	05:02	4	02:00



Dialogue

41. VICTOR (hallucine)
Quoi ! Lui, Dark Vapor ?

Scene	Duration	Panel	Duration
76	06:06	1	00:22



Dialogue

41. VICTOR (hallucine)
Avec sa toute petite voix ridicule !

Scene	Duration	Panel	Duration
76	06:06	2	00:22



Dialogue

41. VICTOR (hallucine)
Avec sa toute petite voix ridicule !

Scene	Duration	Panel	Duration
76	06:06	3	00:13



Dialogue

41. VICTOR (hallucine)
Avec sa toute petite voix ridicule !

Scene	Duration	Panel	Duration
76	06:06	4	00:05



Dialogue
 42. TOM/VOIX de grégor
 Pardon ? Qui a une toute petite voix
 ridicule ?

Scene	Duration	Panel	Duration
76	06:06	5	01:21



Dialogue
 42. TOM/VOIX de grégor
 Pardon ? Qui a une toute petite voix
 ridicule ?

Scene	Duration	Panel	Duration
76	06:06	6	00:13



Dialogue
 42. TOM/VOIX de grégor
 Pardon ? Qui a une toute petite voix
 ridicule ?

Scene	Duration	Panel	Duration
76	06:06	7	00:10

Scene	Duration	Panel	Duration
76	06:06	8	01:00

NO PANEL

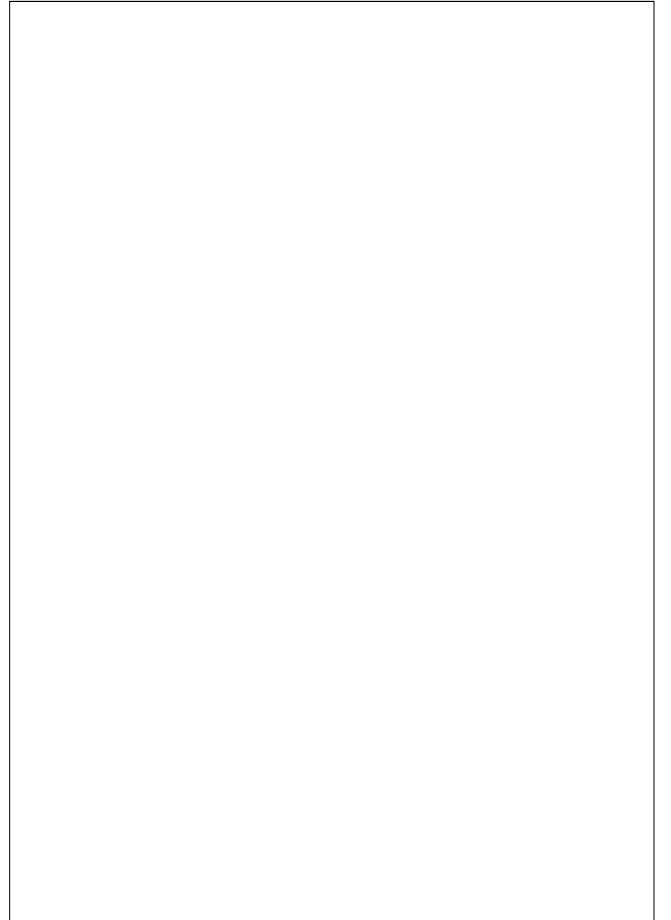
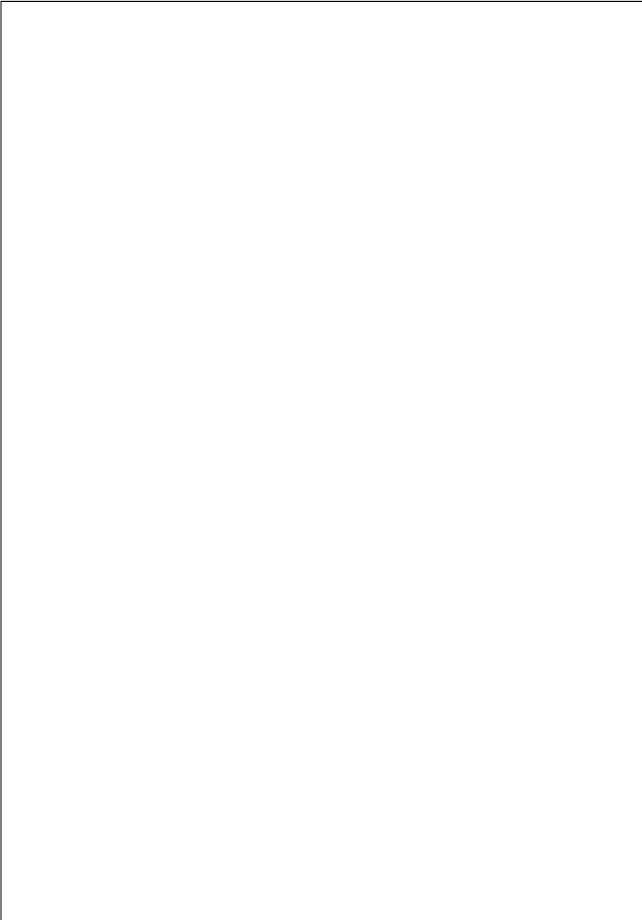
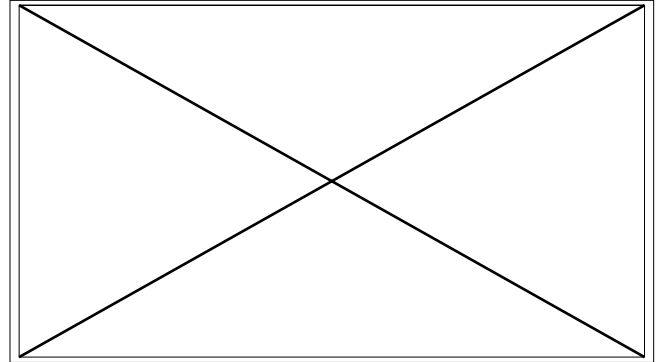

Scene	Duration	Panel	Duration
77	02:24	1	02:24



Dialogue
 43. La classe
 <rires>

Scene	Duration	Panel	Duration
78	03:04	1	03:04



Dialogue
 44. Férocia/voix de Willow
 Mais oui, Mme Lumberk, je vous assure !

Scene	Duration	Panel	Duration
79	02:20	1	00:10

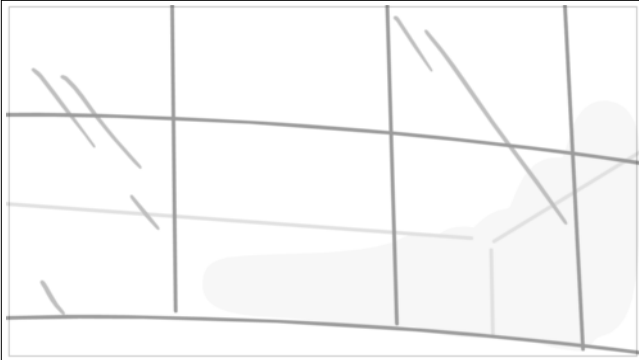

Dialogue
 44. Férocía/voix de Willow
 Votre mari est parti au travail sans son pantalon...

Action Notes
 10. INT. SALON DES FEERICKSEN - JOUR

Scene	Duration	Panel	Duration
79	02:20	2	00:24

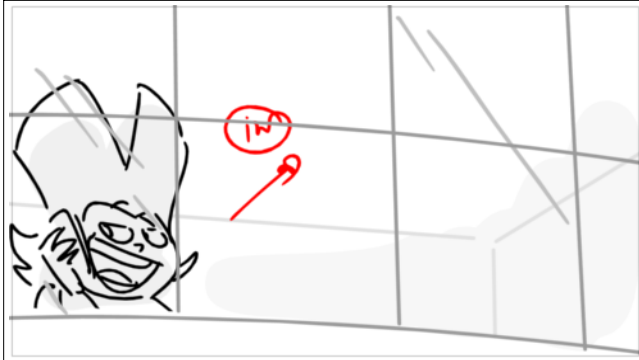

Dialogue
 44. Férocía/voix de Willow
 Votre mari est parti au travail sans son pantalon...

Scene	Duration	Panel	Duration
79	02:20	3	01:11



Dialogue
 44. Férocía/voix de Willow
 Votre mari est parti au travail sans son pantalon...

Scene	Duration	Panel	Duration
80	16:11	1	01:23



Dialogue

44. Férocia/voix de Willow
Si, si, juré.

Scene	Duration	Panel	Duration
80	16:11	2	04:15

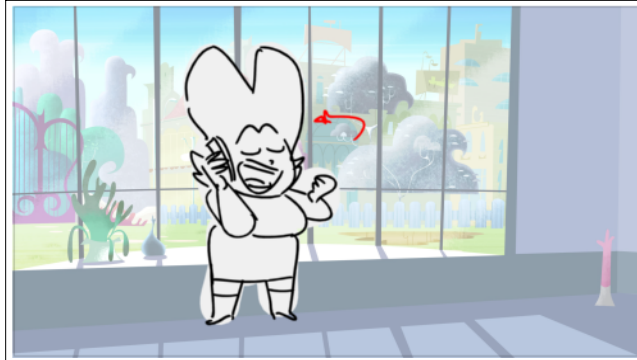

Dialogue

44. Férocia/voix de Willow
Voyons Mme Lumberk, vous pouvez croire
sur parole votre gentille voisine
Willow...

Scene	Duration	Panel	Duration
80	16:11	3	02:01

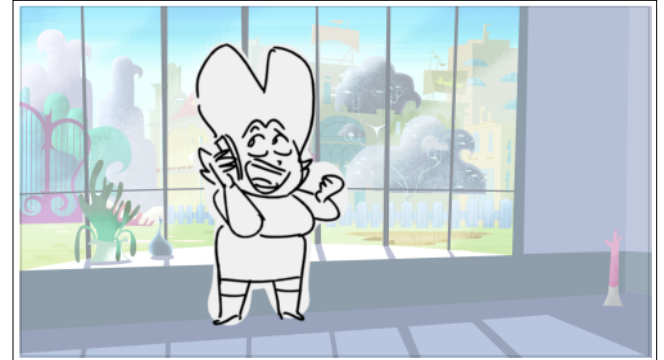

Dialogue

44. Férocia/voix de Willow
Voilà. (pause) Mais de rien !



Scene	Duration	Panel	Duration
80	16:11	4	00:14



Action Notes

Férocia raccroche en pouffant

Scene	Duration	Panel	Duration
80	16:11	5	00:24

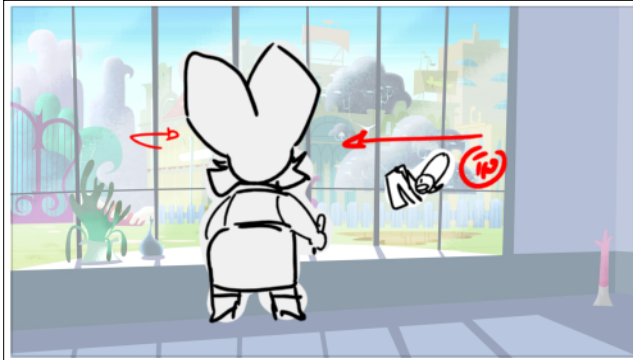

Action Notes

Madame Linberg +pantalon IN /OUT

Scene	Duration	Panel	Duration
80	16:11	6	01:03



Scene	Duration	Panel	Duration
80	16:11	7	00:13



Dialogue

45. Férocía/voix de Willow
<rire cristalin>

Scene	Duration	Panel	Duration
80	16:11	8	00:11



Dialogue

45. Férocía/voix de Willow
<rire cristalin>

Scene	Duration	Panel	Duration
80	16:11	9	00:10

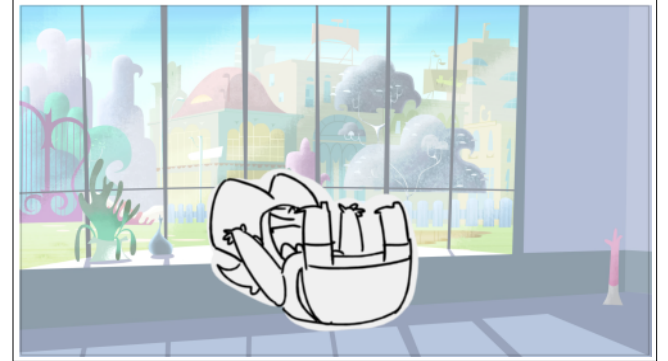

Dialogue

45. Férocía/voix de Willow
<rire cristalin>

Scene	Duration	Panel	Duration
80	16:11	10	00:14



Dialogue

45. Férocía/voix de Willow
<rire cristalin>

Scene	Duration	Panel	Duration
80	16:11	11	00:11

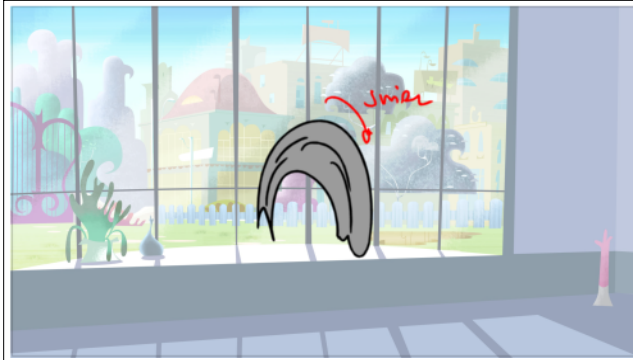

Scene	Duration	Panel	Duration
80	16:11	12	01:13



Dialogue

PU Férocía/voix de Willow
Nan mais quel rire de naze!



Scene	Duration	Panel	Duration
80	16:11	13	00:13



Scene	Duration	Panel	Duration
80	16:11	14	00:13



Scene	Duration	Panel	Duration
80	16:11	15	00:08

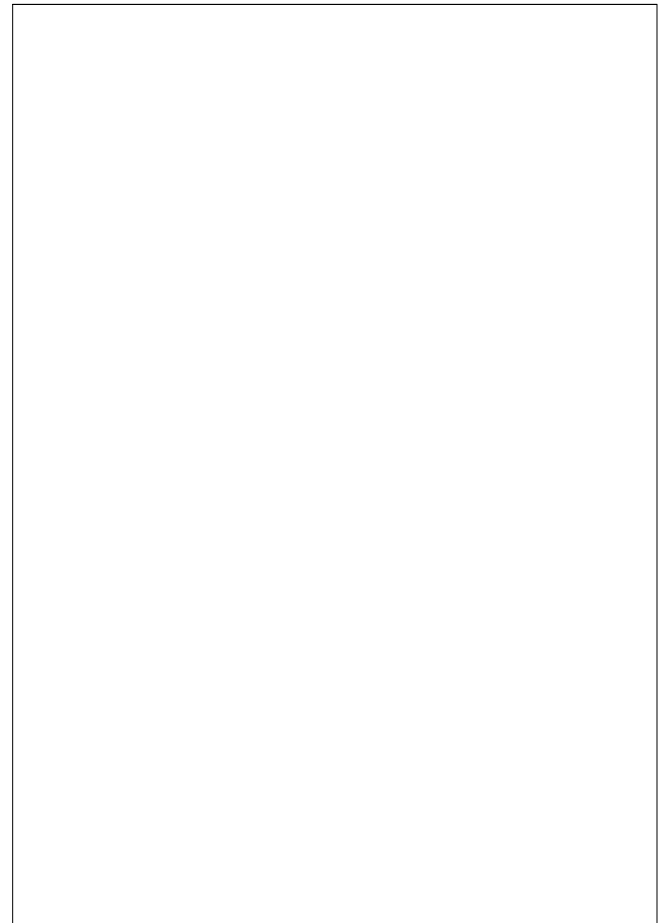
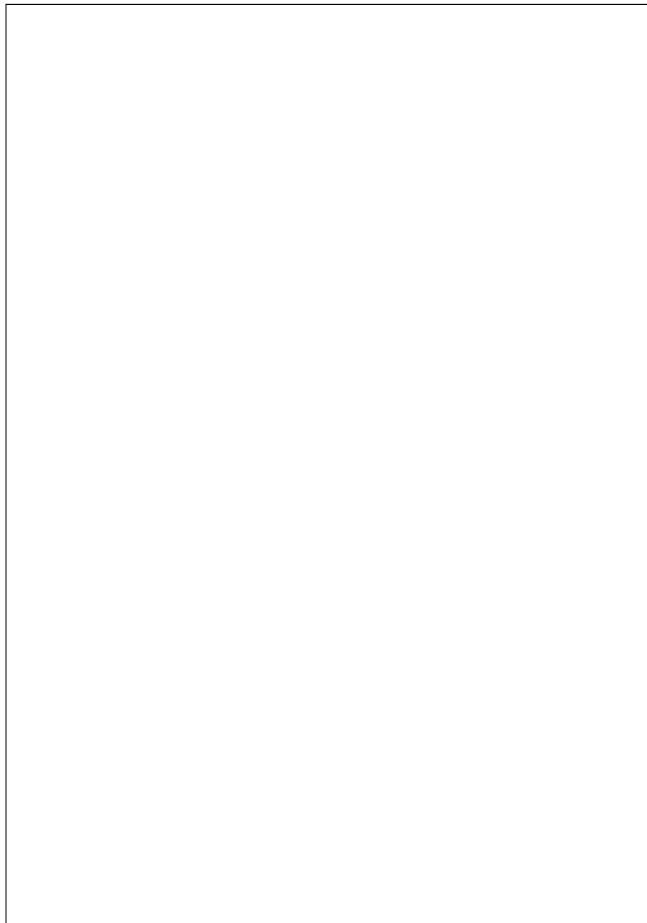

Scene	Duration	Panel	Duration
81	02:23	1	02:23



Dialogue

46. Monseigneur/VOIX DE CINDY
Les adjectifs se terminant par « il »

Scene	Duration	Panel	Duration
82	01:00	1	01:00



Dialogue

46. Monseigneur/VOIX DE CINDY
ont la même forme au féminin qu'au masculin...

Action Notes

Monseigneur sous la chaise de cindy derrière son sac avec une antisèche. Cindy nerveuse cache sa bouche avec ses cheveux. Elle tente tant bien que mal de suivre en post-synchro les propos de Monseigneur.

Scene	Duration	Panel	Duration
83	02:00	1	01:00



Dialogue

46. Monseigneur/VOIX DE CINDY
ont la même forme au féminin qu'au masculin...

Scene	Duration	Panel	Duration
83	02:00	2	01:00

NO PANEL

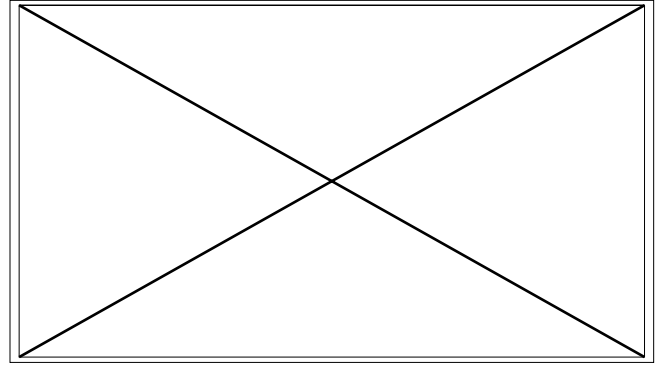
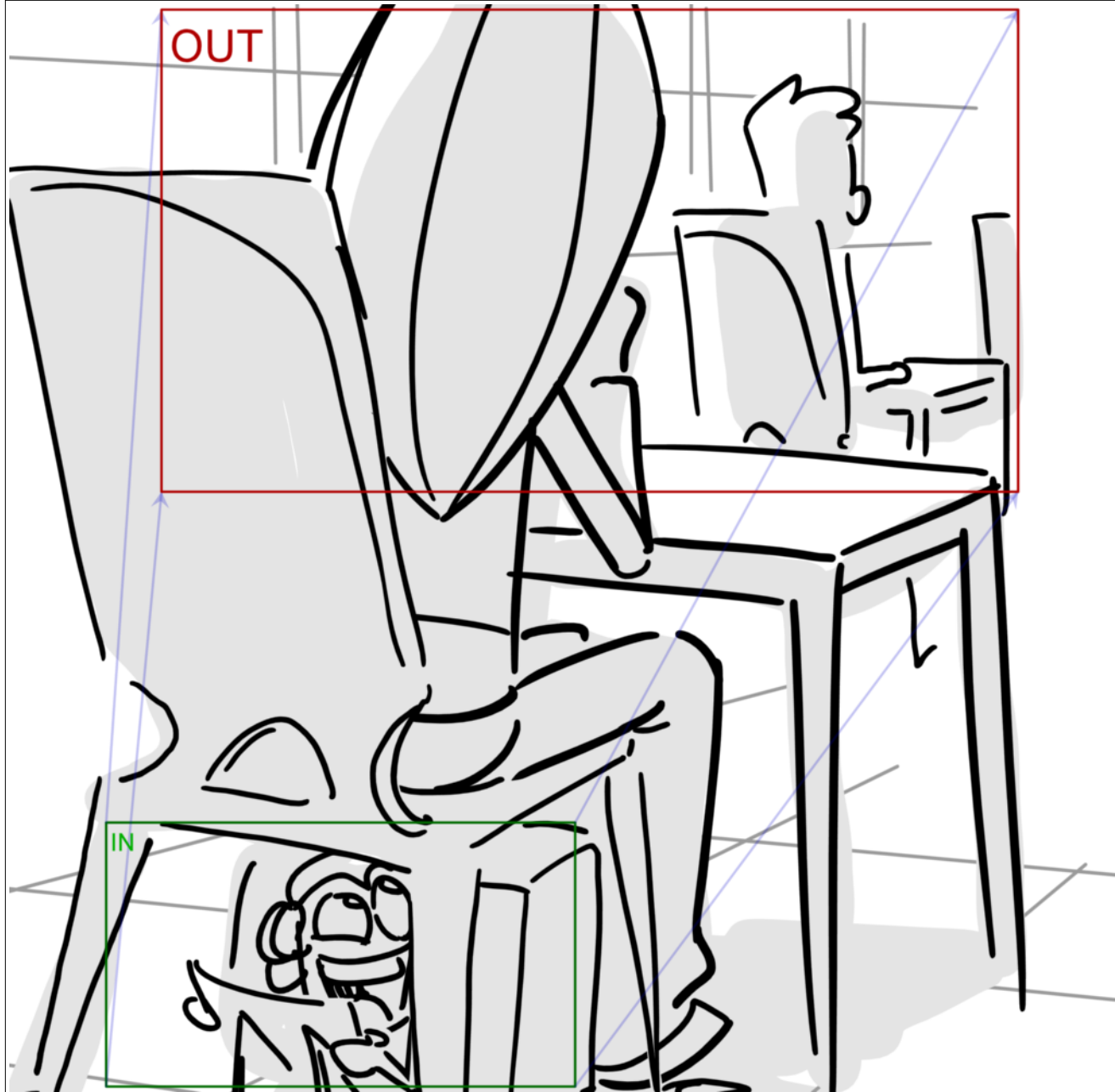

Dialogue
 46. Monseigneur/VOIX DE CINDY
 ont la même forme au féminin qu'au
 masculin...

Scene	Duration	Panel	Duration
84	11:02	1	00:24



Dialogue

46. Monseigneur/VOIX DE CINDY
à l'exception de civil, volatil,
puéril, subtil et bisextil

Scene	Duration	Panel	Duration
84	11:02	2	02:12



Dialogue

46. Monseigneur/VOIX DE CINDY
à l'exception de civil, volatil,
puéril, subtil et bisextil

Scene	Duration	Panel	Duration
84	11:02	3	00:24



Dialogue

46. Monseigneur/VOIX DE CINDY
à l'exception de civil, volatil,
puéril, subtil et bisextil

Scene	Duration	Panel	Duration
84	11:02	4	00:23



Dialogue

46. Monseigneur/VOIX DE CINDY
à l'exception de civil, volatil,
puéril, subtil et bisextil

Scene	Duration	Panel	Duration
84	11:02	5	00:16



Dialogue

46. Monseigneur/VOIX DE CINDY
qui, soit dit en passant, vient du
latin Bis et Sextus.

Action Notes

Cindy surprise que Monseigneur continue

Scene	Duration	Panel	Duration
84	11:02	6	01:00



Dialogue

46. Monseigneur/VOIX DE CINDY
qui, soit dit en passant, vient du
latin Bis et Sextus.

Scene	Duration	Panel	Duration
84	11:02	7	02:07



Dialogue

46. Monseigneur/VOIX DE CINDY
qui, soit dit en passant, vient du
latin Bis et Sextus.

Scene	Duration	Panel	Duration
84	11:02	8	01:00



Dialogue

46. Monseigneur/VOIX DE CINDY
qui, soit dit en passant, vient du
latin Bis et Sextus.

Scene	Duration	Panel	Duration
84	11:02	9	00:21



Action Notes

Cindy souffle soulagée

Scene	Duration	Panel	Duration
85	08:13	1	05:11

Scene	Duration	Panel	Duration
85	08:13	2	01:02

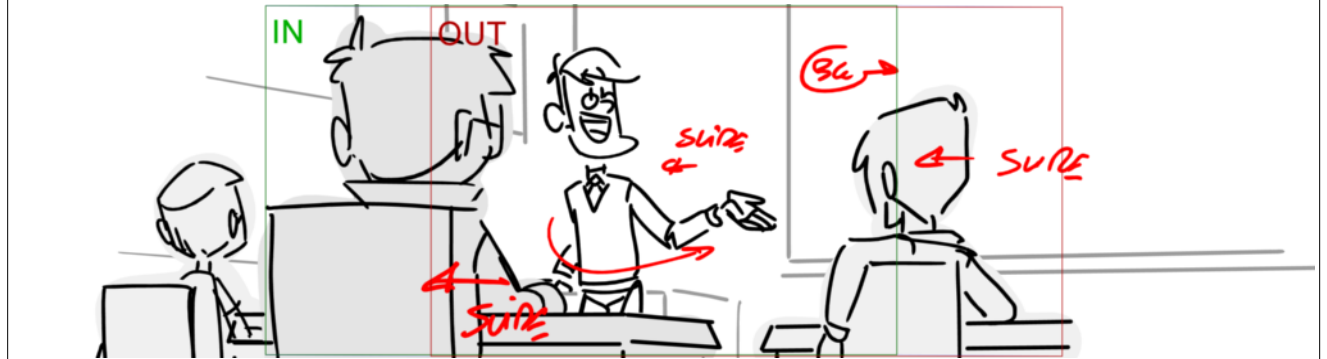

Dialogue

47. PROF DE FRANCAIS
 (très impressionné)
 Eh bien Cindy, que de progrès, tu t'es surpassée !

Dialogue

47. PROF DE FRANCAIS
 Accepterais-tu de donner un cours de soutien à Ahmed. Il en aurait bien besoin...



Scene	Duration	Panel	Duration
85	08:13	3	01:00

Scene	Duration	Panel	Duration
85	08:13	4	01:00

Scene	Duration	Panel	Duration
86	03:01	1	00:05



Dialogue
47. PROF DE FRANCAIS
Accepterais-tu de donner un cours de soutien à Ahmed. Il en aurait bien besoin...

Scene	Duration	Panel	Duration
86	03:01	2	00:11

Scene	Duration	Panel	Duration
86	03:01	3	00:19

NO PANEL

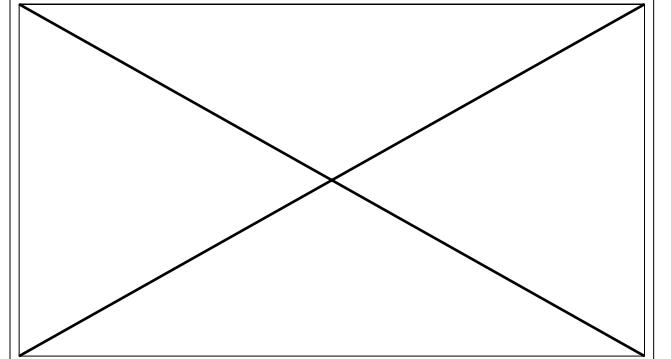

Dialogue
 48. Cindy/VOIX DE MONSEIGNEUR
 Oh ouiiiiiiii !

Dialogue
 48. Cindy/VOIX DE MONSEIGNEUR
 Oh ouiiiiiiii !

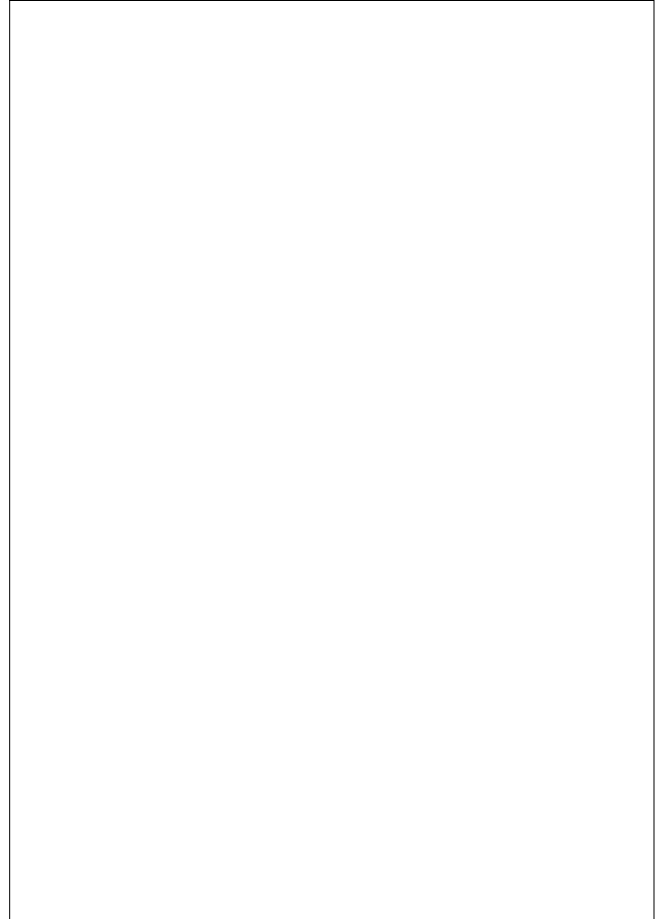



Scene	Duration	Panel	Duration
86	03:01	4	00:15



Scene	Duration	Panel	Duration
86	03:01	5	00:14

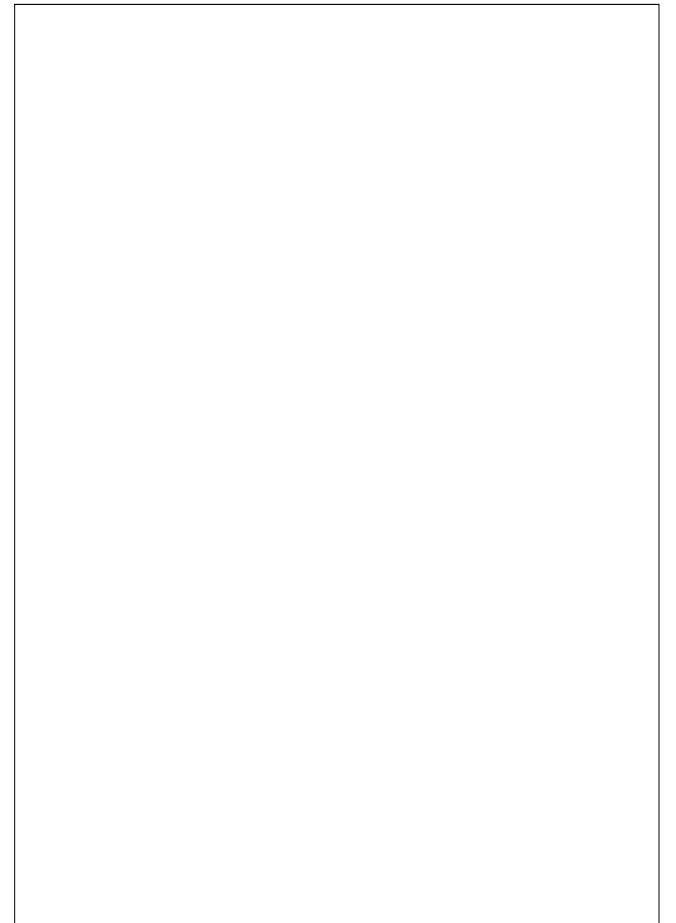
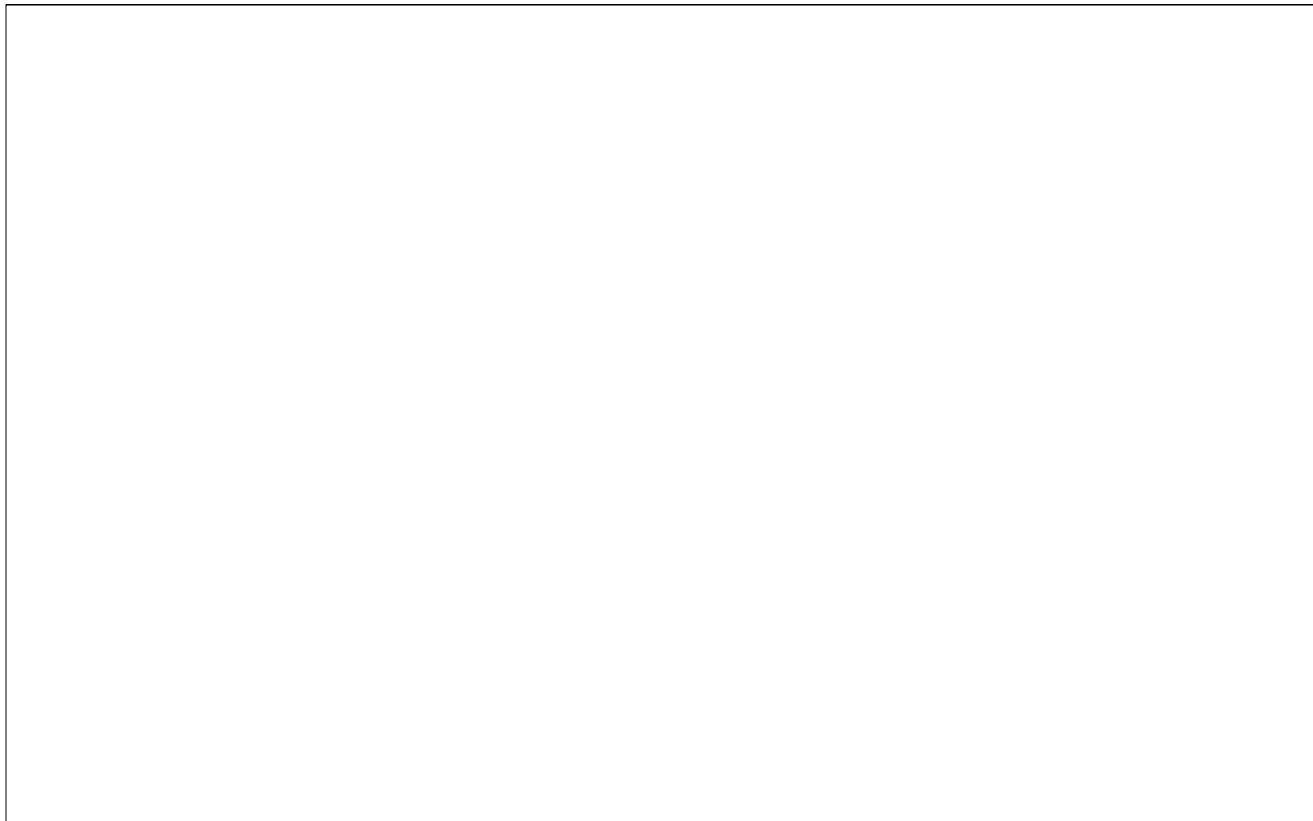
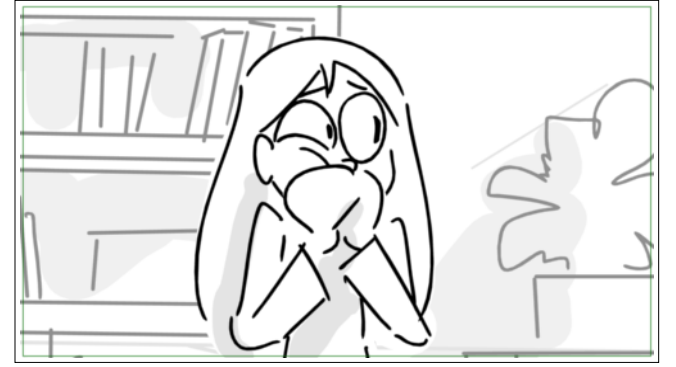



Scene	Duration	Panel	Duration
86	03:01	6	00:12

NO PANEL

NO PANEL

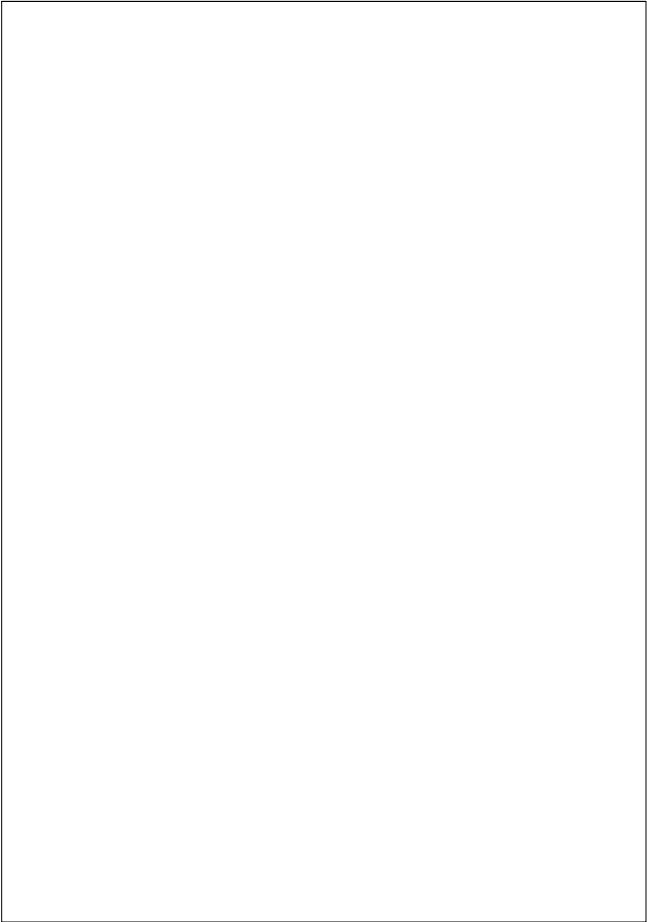
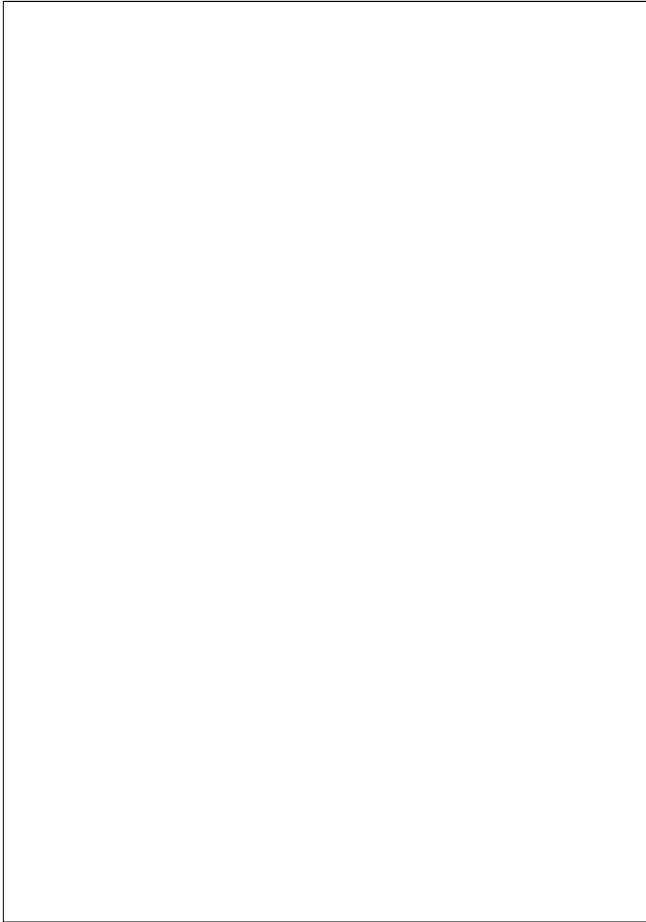
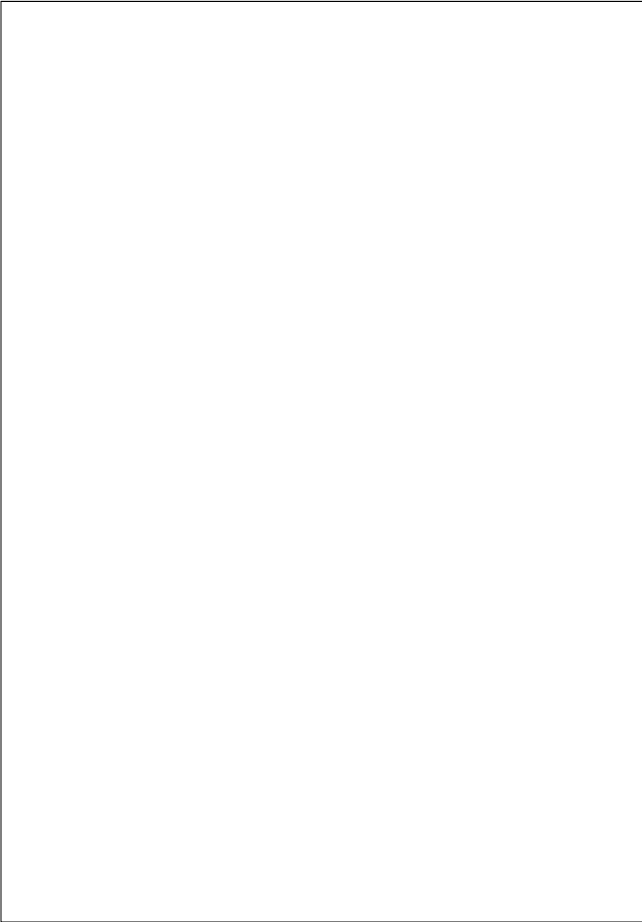
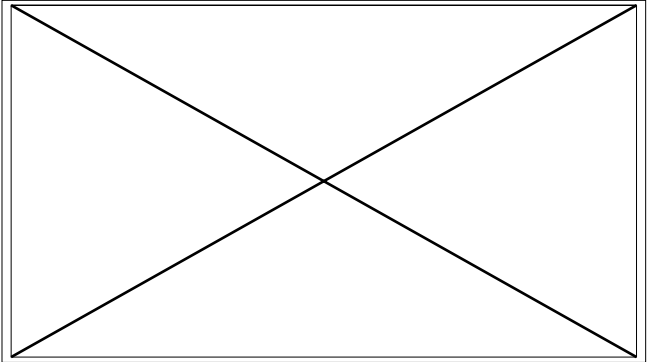
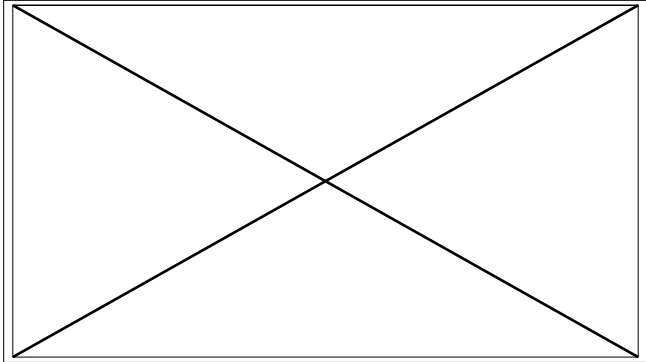
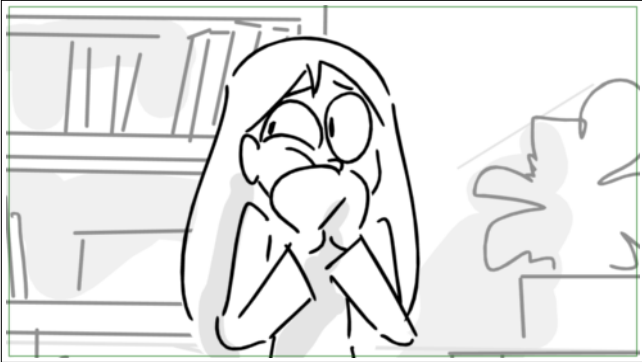

Scene	Duration	Panel	Duration
87	02:11	1	02:11

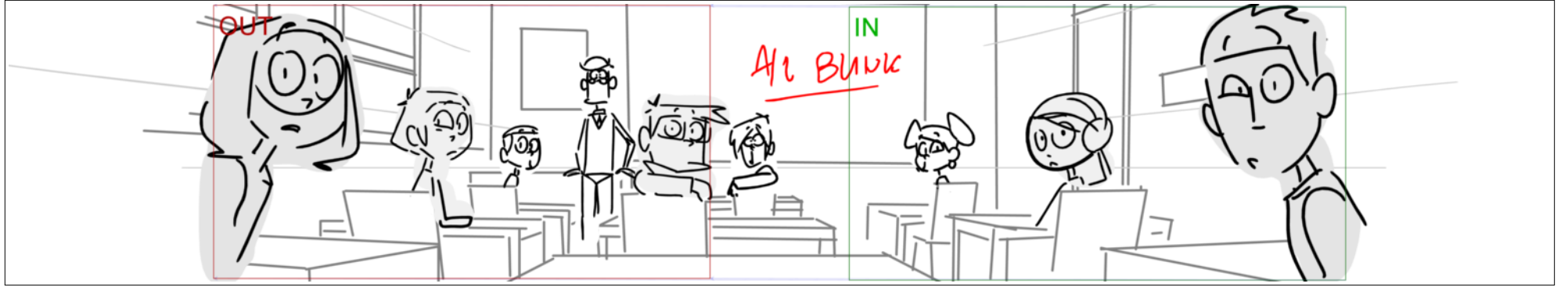

Scene	Duration	Panel	Duration
88	03:12	1	01:00



Scene	Duration	Panel	Duration
88	03:12	2	01:00



Dialogue
 49. Monseigneur/VOIX DE CINDY
 (se racle la gorge et Cindy reprend sa post synchro)
 Pardonnez ce petit écart...

Scene	Duration	Panel	Duration
88	03:12	3	01:12



Dialogue
 49. Monseigneur/VOIX DE CINDY
 (se racle la gorge et Cindy reprend sa post synchro)
 Pardonnez ce petit écart...

Scene	Duration	Panel	Duration
89	04:20	1	00:18



Dialogue
 49. Monseigneur/VOIX DE CINDY
 Je voulais dire :

Scene	Duration	Panel	Duration
89	04:20	2	00:23



Dialogue
 49. Monseigneur/VOIX DE CINDY
 Je voulais dire :

Scene	Duration	Panel	Duration
89	04:20	3	02:06

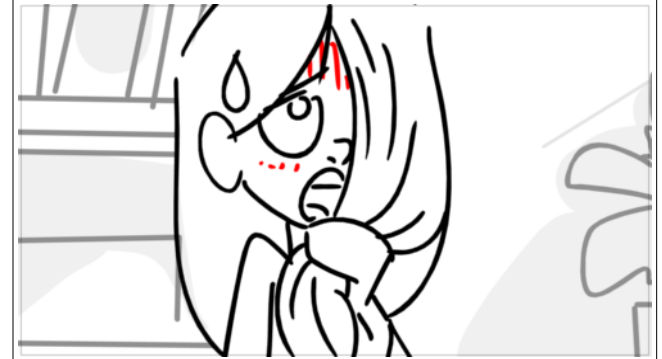

Dialogue
 49. Monseigneur/VOIX DE CINDY
 Je voulais dire :

Scene	Duration	Panel	Duration
89	04:20	4	00:23

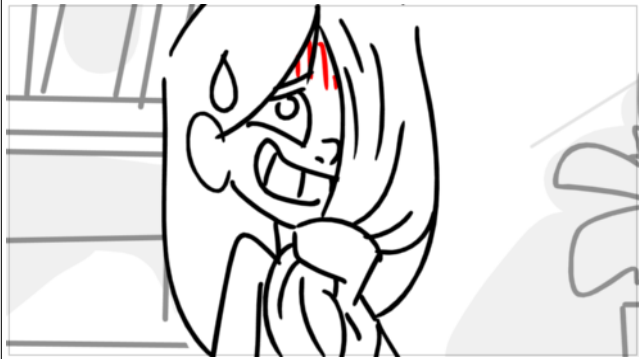

Dialogue

49. Monseigneur/VOIX DE CINDY
je suis fort aise de pouvoir aider mon camarade.

Scene	Duration	Panel	Duration
90	01:20	1	01:20



Scene	Duration	Panel	Duration
91	02:08	1	01:04



Action Notes

12. INT. CUISINE DES FEERICKSEN - JOUR

Scene	Duration	Panel	Duration
91	02:08	2	01:04



Action Notes

Main de Gregor IN met du poivre

Scene	Duration	Panel	Duration
92	03:01	1	01:00



Scene	Duration	Panel	Duration
92	03:01	2	01:00



Scene	Duration	Panel	Duration
92	03:01	3	01:01

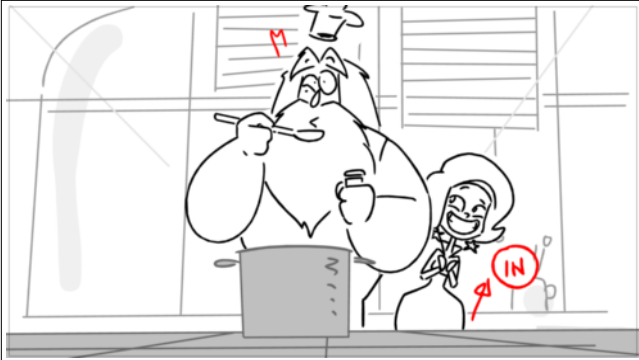

Dialogue

50. WILLOW/voix de Férocia
 Tu me fais goûter, Grégorichou ?

Scene	Duration	Panel	Duration
93	10:11	1	00:07



Scene	Duration	Panel	Duration
93	10:11	2	00:07



Scene	Duration	Panel	Duration
93	10:11	3	00:23



Scene	Duration	Panel	Duration
93	10:11	4	01:20



Dialogue

51. Grégor/Voix de TOM
Désolée ma libellule,

Scene	Duration	Panel	Duration
93	10:11	5	01:14



Dialogue

51. Grégor/Voix de TOM
je n'arrive pas à m'y faire...

Scene	Duration	Panel	Duration
93	10:11	6	02:17



Dialogue
 52. Willow/voix de Férocía
 Mais, je suis toujours la même, Tom !

Scene	Duration	Panel	Duration
93	10:11	7	00:15



Dialogue
 52. Willow/voix de Férocía
 Euh

Scene	Duration	Panel	Duration
93	10:11	8	01:08



Dialogue
 52. Willow/voix de Férocía
 Grégor !!

Scene	Duration	Panel	Duration
93	10:11	9	01:00



Dialogue
SFX DING DONG

Scene	Duration	Panel	Duration
94	02:02	1	00:13



Scene	Duration	Panel	Duration
94	02:02	2	00:15

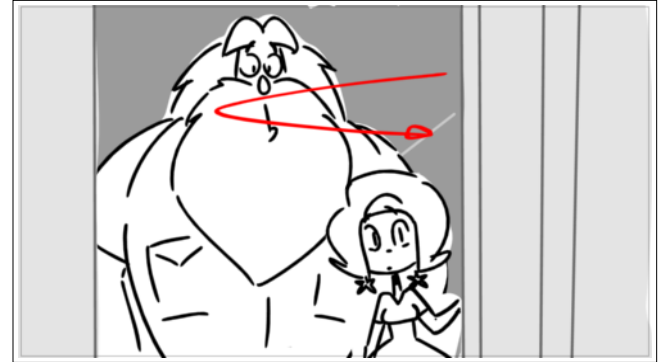

Scene	Duration	Panel	Duration
94	02:02	3	00:08



Action Notes

Gregor prend le pantalon dans la figure

Scene	Duration	Panel	Duration
94	02:02	4	00:16

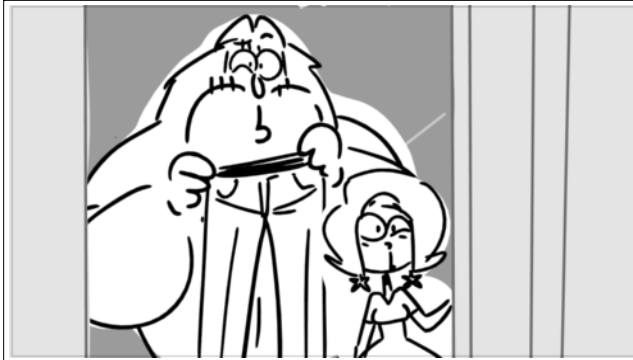

Scene	Duration	Panel	Duration
95	05:13	1	02:09



Dialogue

53. Mme Lumberk

J'imagine que vous trouvez ça drôle,
votre histoire de... De pantalon !!?



Scene	Duration	Panel	Duration
95	05:13	2	01:08

Scene	Duration	Panel	Duration
95	05:13	3	01:14

Scene	Duration	Panel	Duration
95	05:13	4	00:07

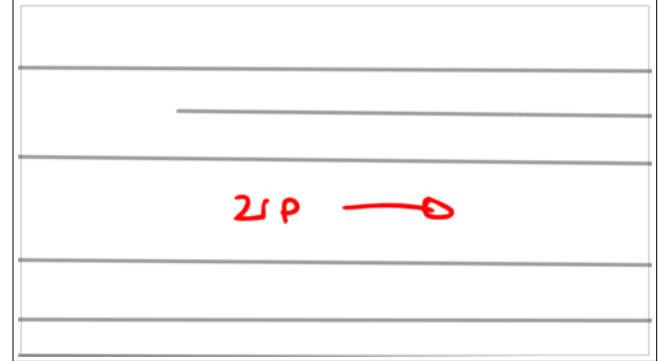

Dialogue

53. Mme Lumberk
J'imagine que vous trouvez ça drôle,
votre histoire de... De pantalon !!?

Dialogue

53. Mme Lumberk
J'imagine que vous trouvez ça drôle,
votre histoire de... De pantalon !!?

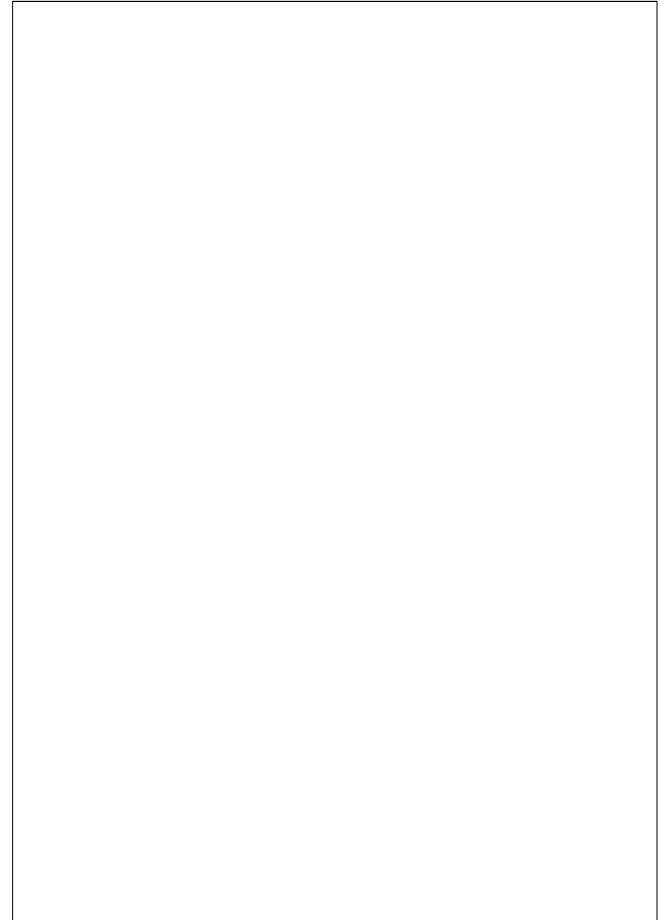

Scene	Duration	Panel	Duration
96	02:08	1	00:09



Scene	Duration	Panel	Duration
96	02:08	2	00:19



Action Notes

INSERT
 Mme Lumberk débarque à une réunion de travail de Mr Lumberk

Scene	Duration	Panel	Duration
96	02:08	3	00:15





Scene	Duration	Panel	Duration
96	02:08	4	00:15



Scene	Duration	Panel	Duration
97	03:00	1	00:10



Scene	Duration	Panel	Duration
97	03:00	2	00:15

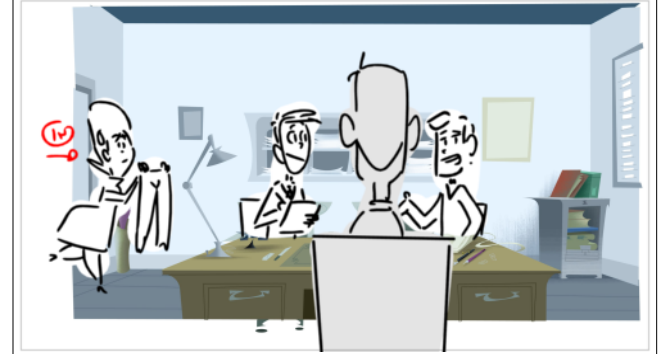

Scene	Duration	Panel	Duration
97	03:00	3	01:00

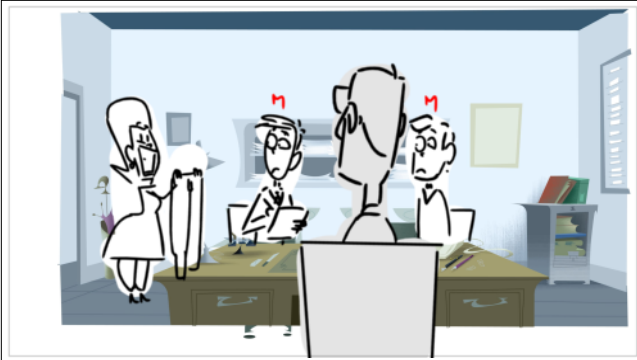

Scene	Duration	Panel	Duration
97	03:00	4	01:00



Action Notes

Les collègues se mettent à rire

Scene	Duration	Panel	Duration
98	02:00	1	01:00



Scene	Duration	Panel	Duration
98	02:00	2	01:00



Scene	Duration	Panel	Duration
99	02:00	1	01:00

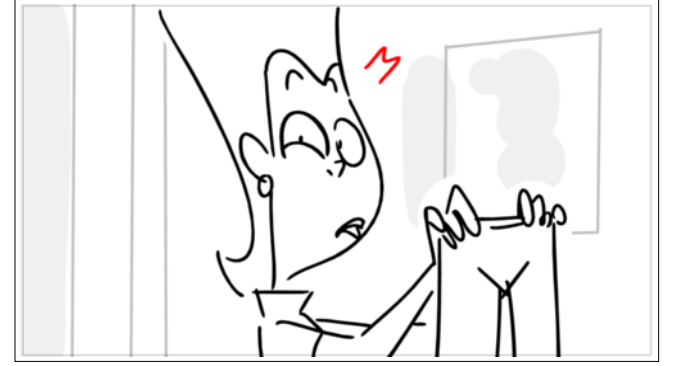

Action Notes

Monsieur Limerg se lève. Il a déjà un pantalon

Scene	Duration	Panel	Duration
99	02:00	2	01:00



Action Notes

Tête embarrassée de madame Lumberg

Scene	Duration	Panel	Duration
100	08:24	1	00:16



Scene	Duration	Panel	Duration
100	08:24	2	02:19

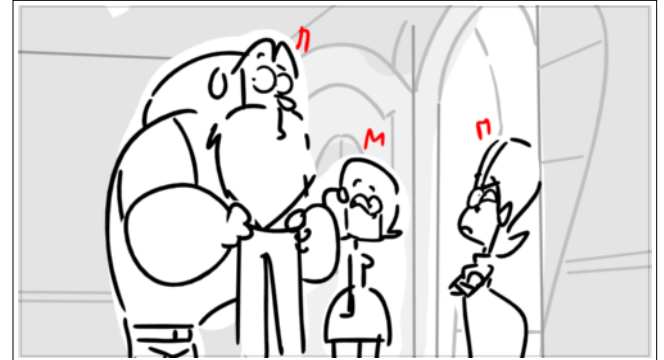

Dialogue

45. Férocia/voix de Willow
<rire cristalin>

Scene	Duration	Panel	Duration
100	08:24	3	00:09



Scene	Duration	Panel	Duration
100	08:24	4	02:15



Dialogue
 54. Mme Lumberk
 Votre muflerie me laisse sans voix !

Scene	Duration	Panel	Duration
100	08:24	5	01:00



Scene	Duration	Panel	Duration
100	08:24	6	00:14



Scene	Duration	Panel	Duration
100	08:24	7	01:01



Dialogue

PU WILLOW et GREGOR
Férocia!

Scene	Duration	Panel	Duration
101	02:18	1	01:00



Dialogue

45. Férocia/voix de Willow
<rire cristalin>

Scene	Duration	Panel	Duration
101	02:18	2	00:10

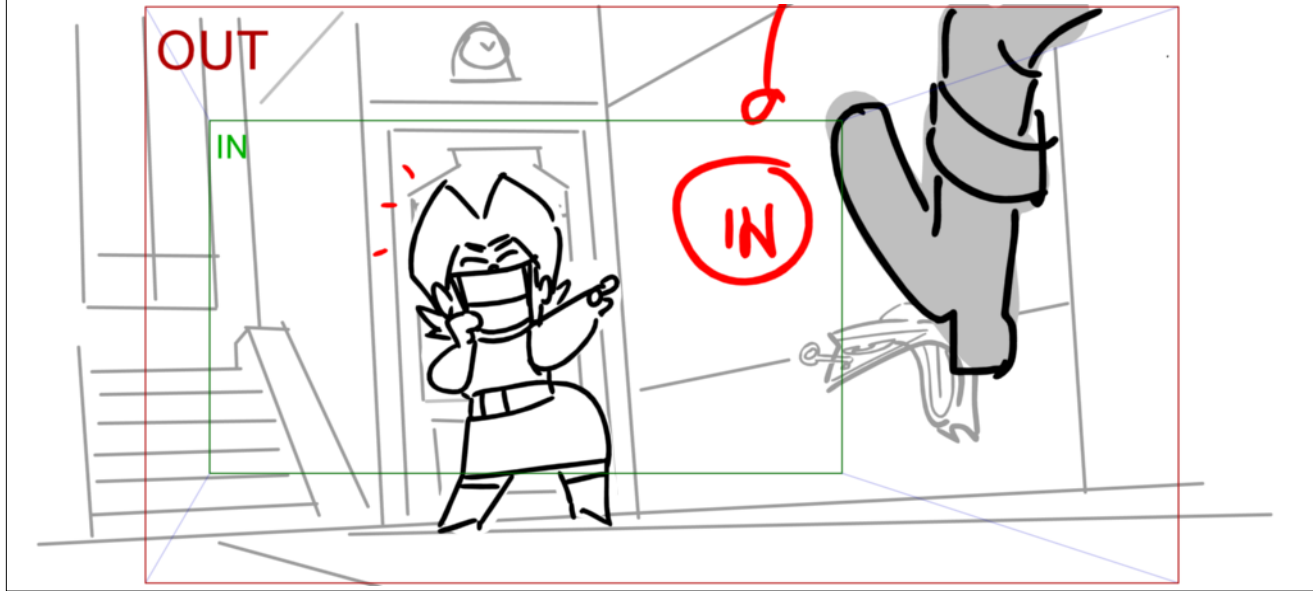

Scene	Duration	Panel	Duration
101	02:18	3	00:13

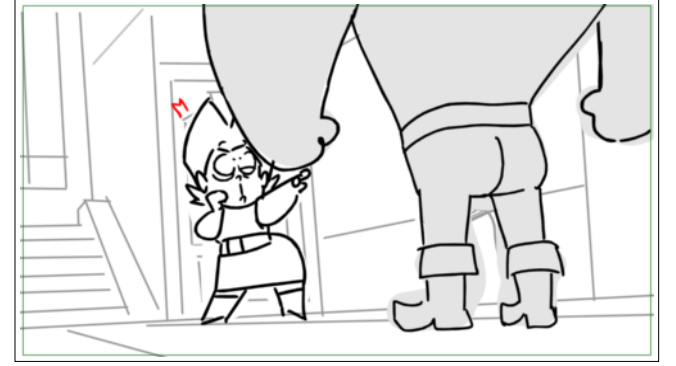

Dialogue

45. Férocía/voix de Willow
 <rire cristalin>

Scene	Duration	Panel	Duration
101	02:18	4	00:04

Scene	Duration	Panel	Duration
101	02:18	5	00:16

Scene	Duration	Panel	Duration
102	04:24	1	00:12

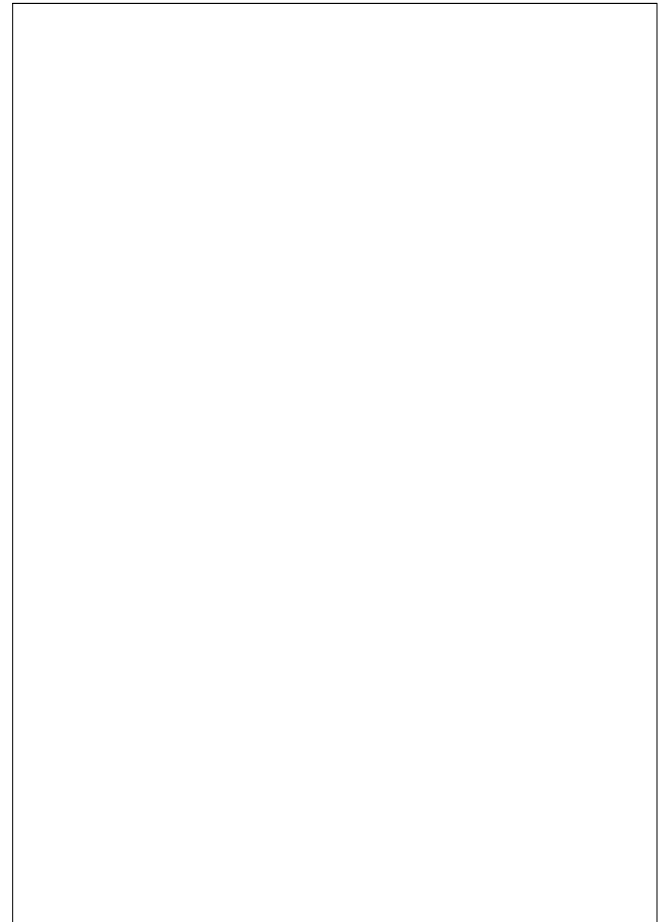
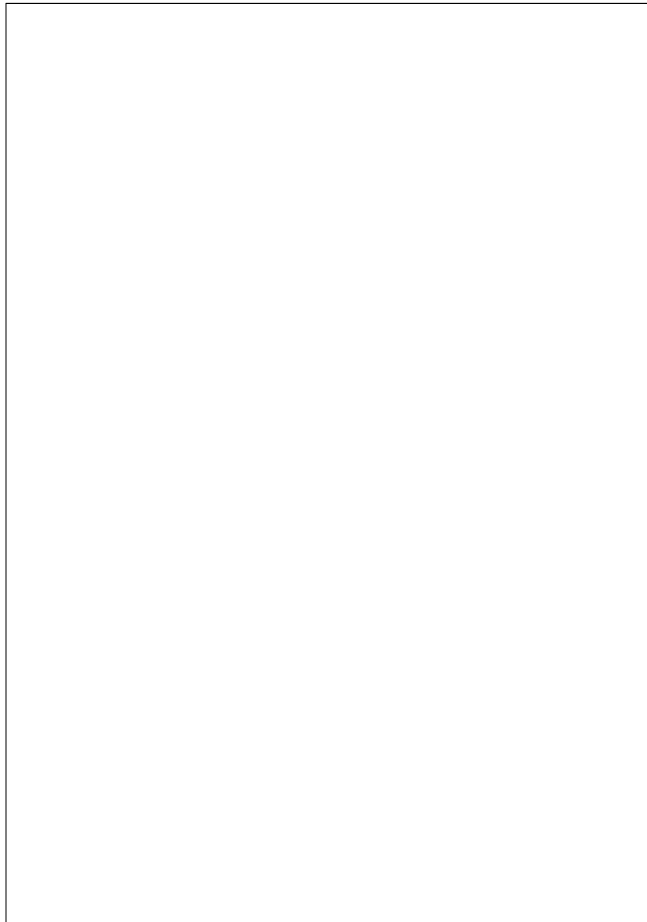
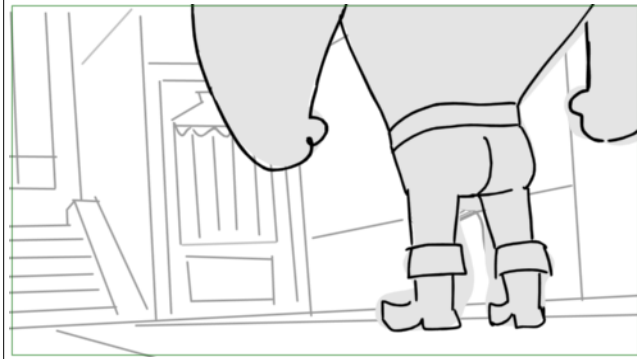
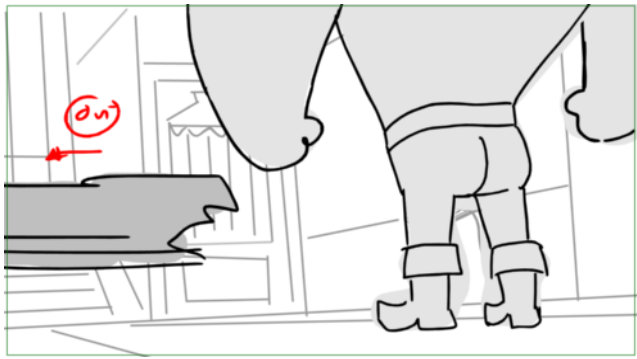



Scene	Duration	Panel	Duration
102	04:24	2	00:09



Action Notes

Gregor prend le téléphone

Scene	Duration	Panel	Duration
102	04:24	3	00:10



Scene	Duration	Panel	Duration
102	04:24	4	00:15



Action Notes

le laisse tomber dans le tiroir

Scene	Duration	Panel	Duration
102	04:24	5	00:11



Action Notes

le referme à clé

Scene	Duration	Panel	Duration
102	04:24	6	00:20



Dialogue

55. Gregor/voix de Tom
Cinq ans d'âge mental, celle-là !

Action Notes

Et repart avec la clé

Scene	Duration	Panel	Duration
102	04:24	7	00:21



Dialogue

55. Gregor/voix de Tom
Cinq ans d'âge mental, celle-là !

Scene	Duration	Panel	Duration
102	04:24	8	00:18

Scene	Duration	Panel	Duration
102	04:24	9	00:08

Scene	Duration	Panel	Duration
103	01:11	1	00:11



Dialogue

55. Gregor/voix de Tom
Cinq ans d'âge mental, celle-là !



Dialogue

55. Gregor/voix de Tom
Cinq ans d'âge mental, celle-là !

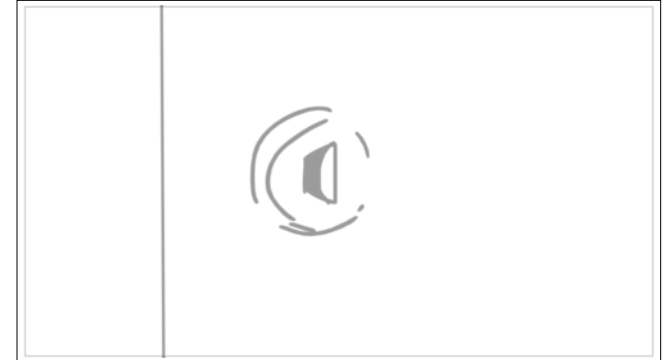

Scene	Duration	Panel	Duration
103	01:11	2	01:00

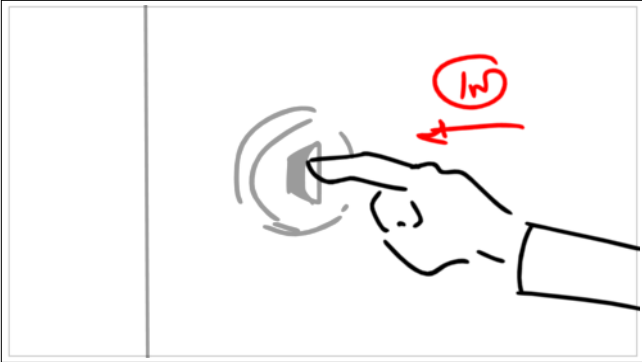

Scene	Duration	Panel	Duration
104	11:07	1	00:14



Scene	Duration	Panel	Duration
104	11:07	2	00:05

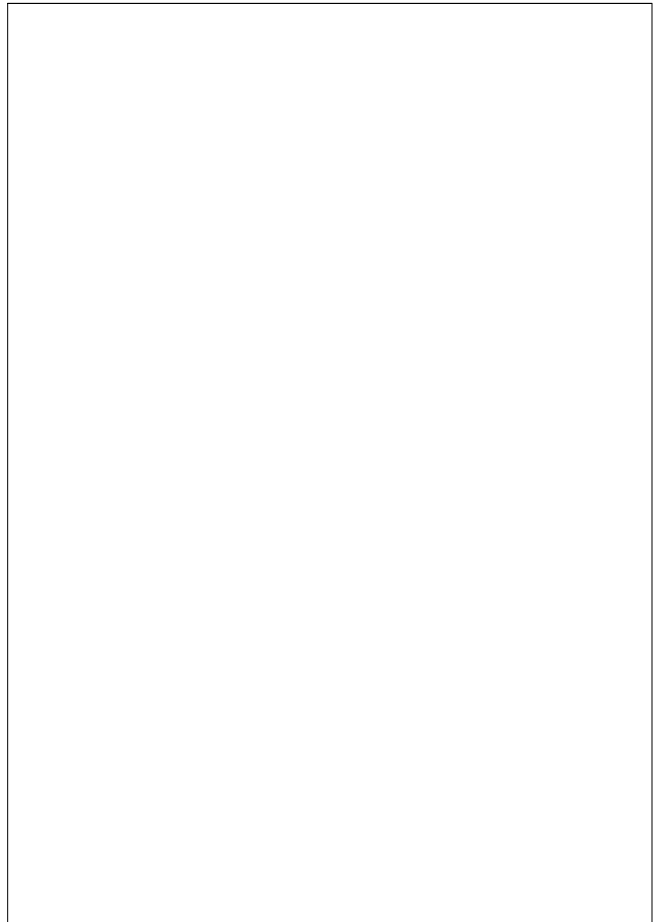
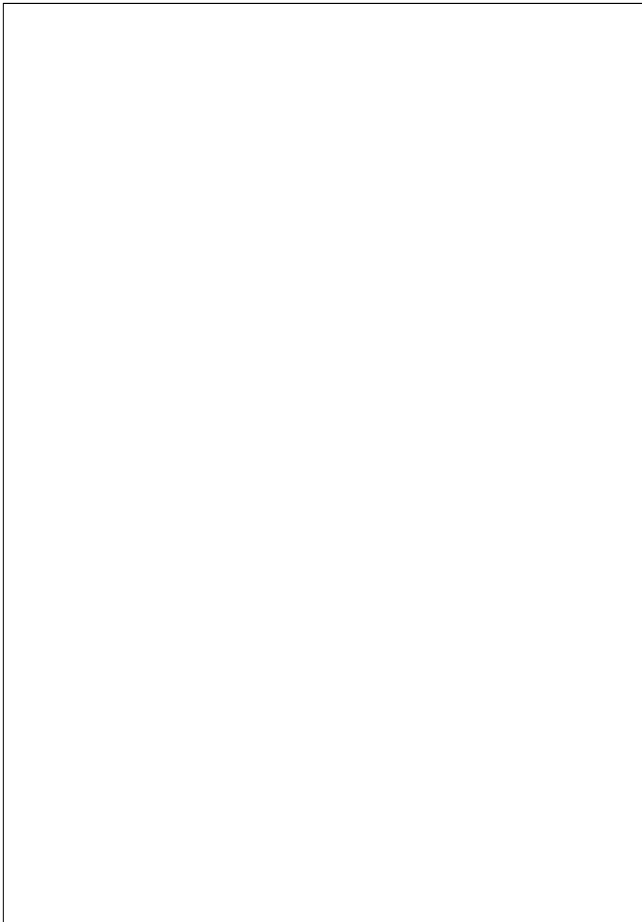
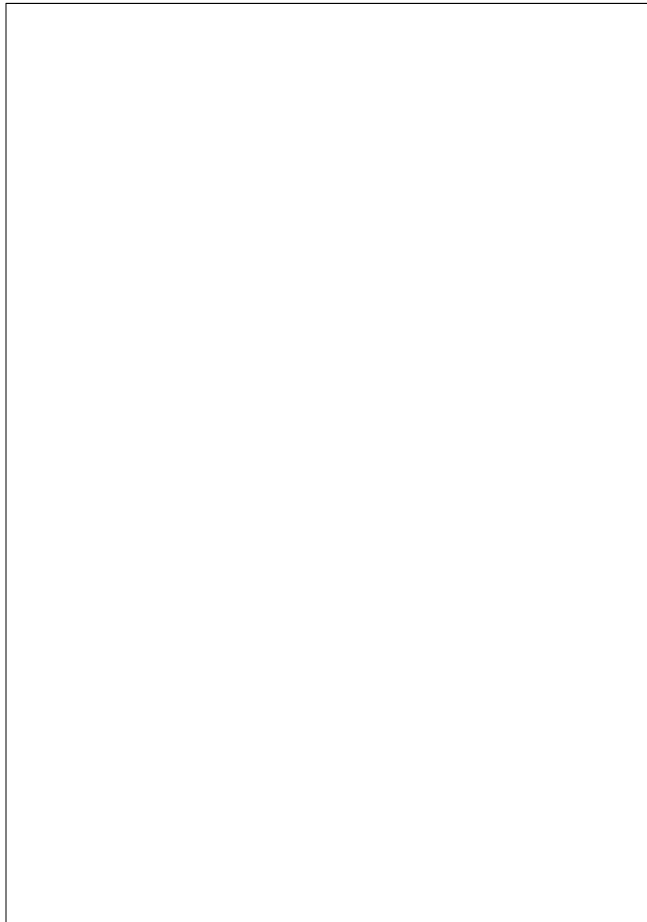
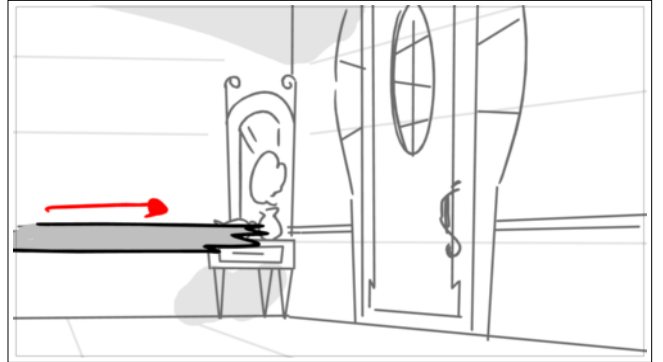



Scene	Duration	Panel	Duration
104	11:07	3	00:06



Scene	Duration	Panel	Duration
104	11:07	4	00:07



Scene	Duration	Panel	Duration
104	11:07	5	00:07

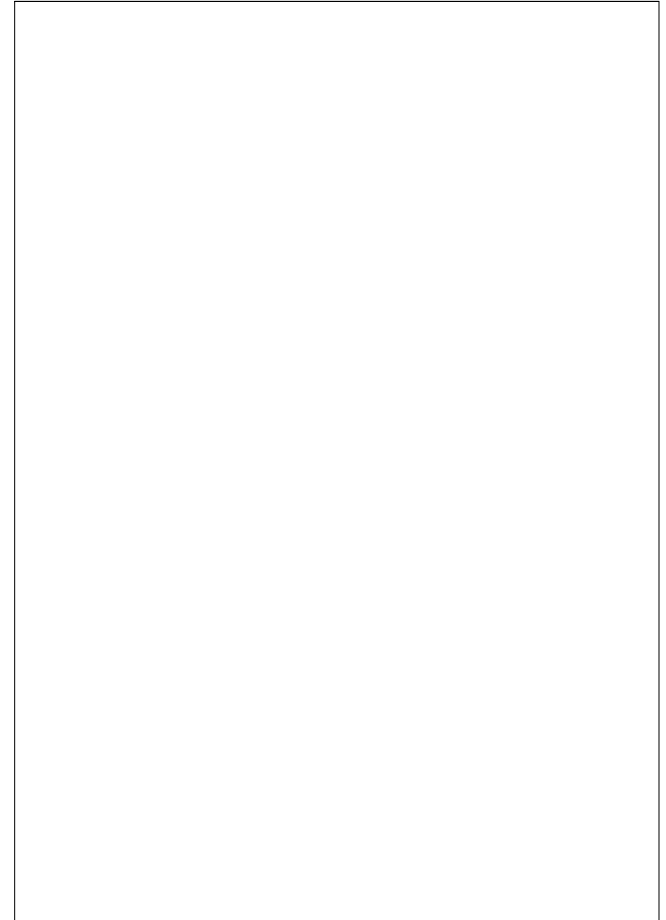
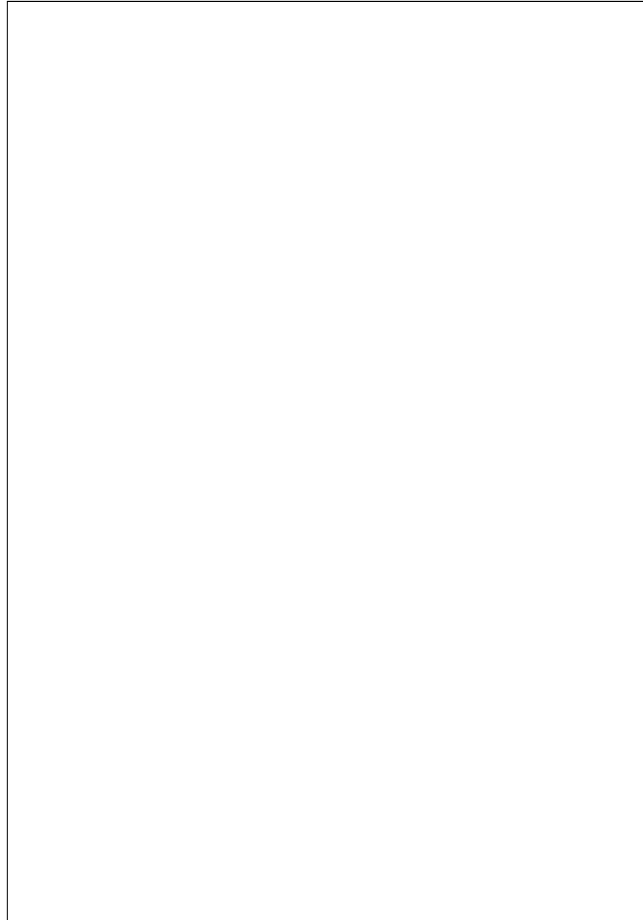
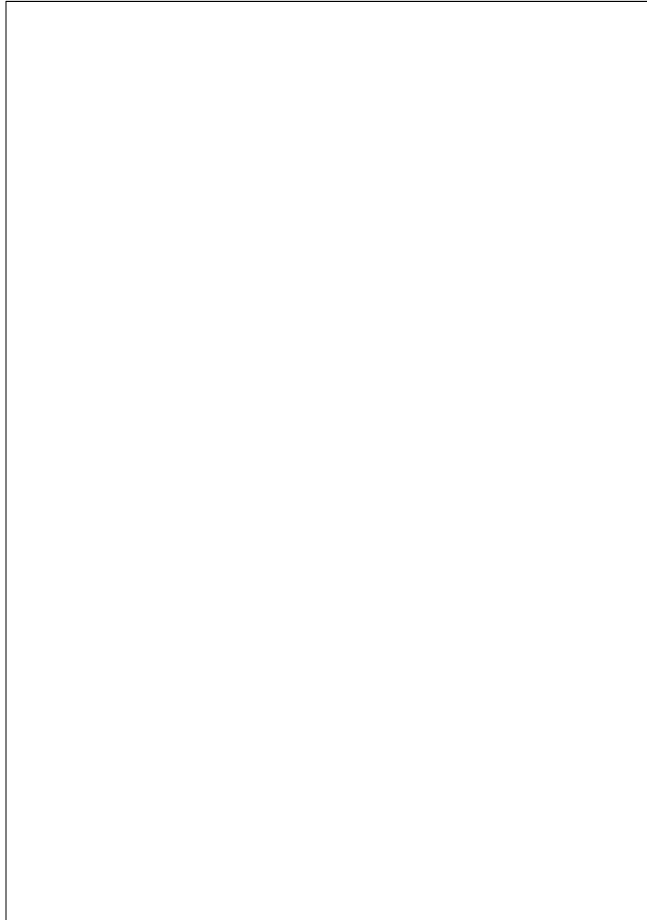



Scene	Duration	Panel	Duration
104	11:07	6	00:07



Scene	Duration	Panel	Duration
104	11:07	7	00:18



Scene	Duration	Panel	Duration
104	11:07	8	02:08



Dialogue

PU CINDY VOIX DE MONSEIGNEUR
C'est Ahmed!

Dialogue

56. MONSEIGNEUR/VOIX DE CINDY
Ce n'est pas le moment de donner ton
cours,

Action Notes

Monseigneur sort de son sac

Scene	Duration	Panel	Duration
104	11:07	9	02:07

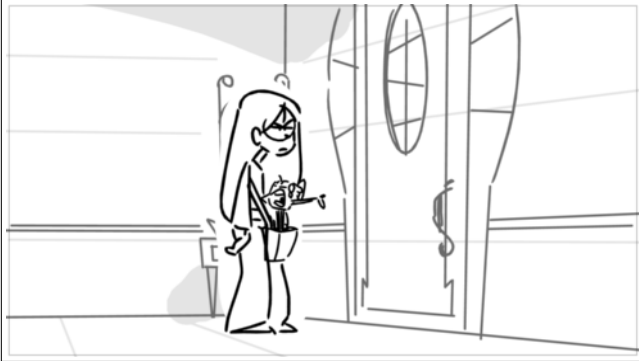

Dialogue

56. MONSEIGNEUR/VOIX DE CINDY
on va être en retard au spectacle de Tom !

Scene	Duration	Panel	Duration
104	11:07	10	00:10



Dialogue

57. CINDY/VOIX DE MONSEIGNEUR
Stresse pas !

Scene	Duration	Panel	Duration
104	11:07	11	01:00

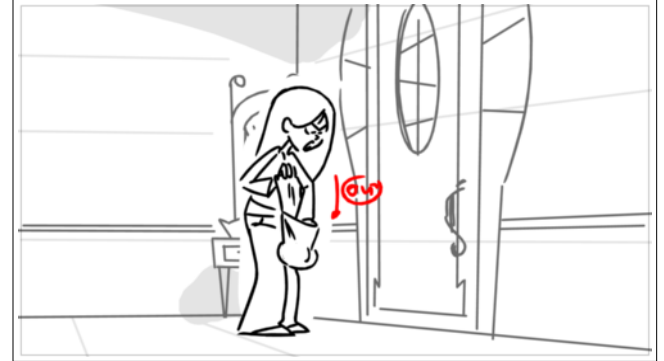

Dialogue

57. CINDY/VOIX DE MONSEIGNEUR
Stresse pas !

Action Notes

Cindy lui replonge la tête dans le sac

Scene	Duration	Panel	Duration
104	11:07	12	01:00



Dialogue
 57. CINDY/VOIX DE MONSEIGNEUR
 On ira après !

Scene	Duration	Panel	Duration
104	11:07	13	00:11

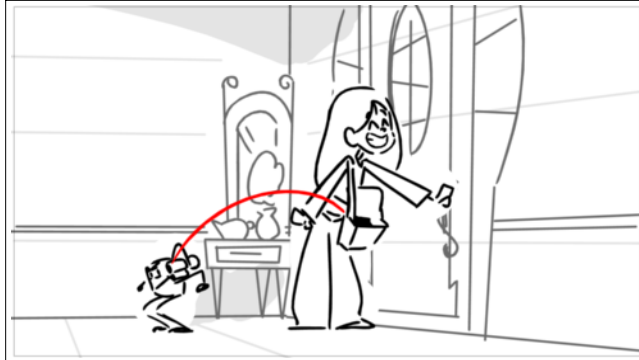

Scene	Duration	Panel	Duration
104	11:07	14	00:07



Scene	Duration	Panel	Duration
104	11:07	15	01:00



Dialogue
60. AHMED
salut Cindy.

Scene	Duration	Panel	Duration
105	02:17	1	00:10



Scene	Duration	Panel	Duration
105	02:17	2	00:16



Action Notes
Cindy commence son playback mais aucun son ne sort

Scene	Duration	Panel	Duration
105	02:17	3	00:13



Action Notes
Elle s'arrête net

Scene	Duration	Panel	Duration
105	02:17	4	00:13



Action Notes
regarde en direction du sac

Scene	Duration	Panel	Duration
105	02:17	5	00:15

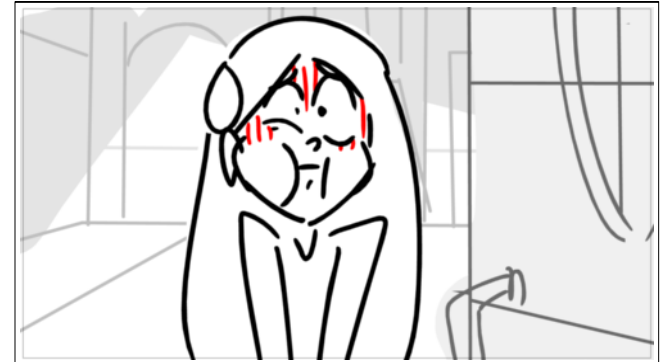

Action Notes
moment de solitude

Scene	Duration	Panel	Duration
106	01:03	1	00:09



Scene	Duration	Panel	Duration
106	01:03	2	00:19

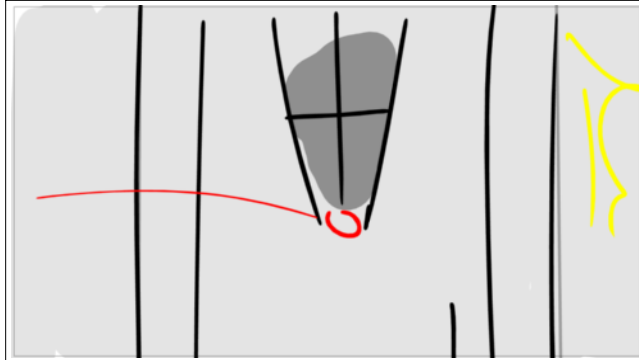

Action Notes
 elle claque la porte au nez d'Ahmed

Scene	Duration	Panel	Duration
107	05:23	1	01:00



Action Notes
 Cindy fouille le sac

Scene	Duration	Panel	Duration
107	05:23	2	00:24



Dialogue
 PU Mais où il est passé!

Action Notes
 il est vide

Scene	Duration	Panel	Duration
107	05:23	3	01:00



Scene	Duration	Panel	Duration
107	05:23	4	00:10

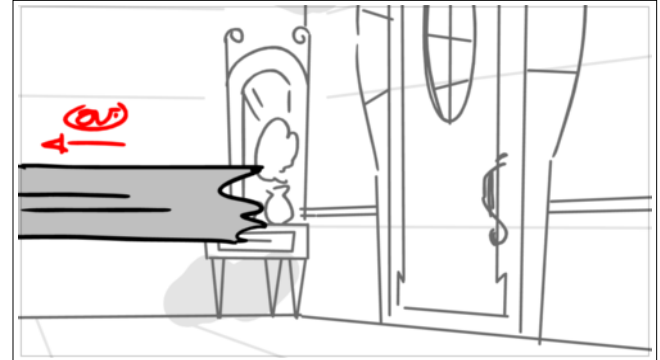

Scene	Duration	Panel	Duration
107	05:23	5	01:00



Scene	Duration	Panel	Duration
107	05:23	6	00:11

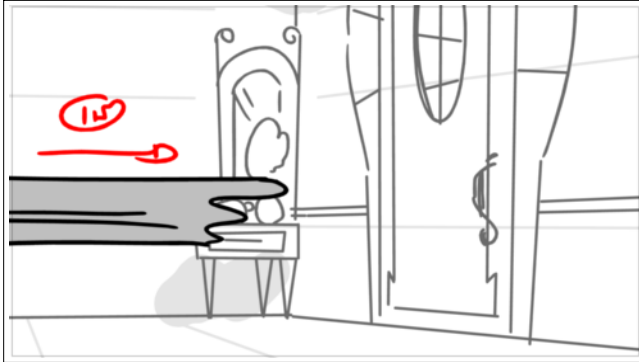

Scene	Duration	Panel	Duration
107	05:23	7	00:10



Dialogue

58. Cindy/voix de Monseigneur
(autoritaire)

Toi,

Scene	Duration	Panel	Duration
107	05:23	8	00:18



Dialogue
 58. Cindy/voix de Monseigneur
 (autoritaire)
 reste ici !

Scene	Duration	Panel	Duration
108	02:04	1	00:05



Dialogue
 58. Cindy/voix de Monseigneur
 (autoritaire)
 Et tu parles normalement à Ahmed !

Scene	Duration	Panel	Duration
108	02:04	2	01:24



Dialogue
 58. Cindy/voix de Monseigneur
 (autoritaire)
 Et tu parles normalement à Ahmed !

Scene	Duration	Panel	Duration
109	02:00	1	01:00



Scene	Duration	Panel	Duration
109	02:00	2	01:00

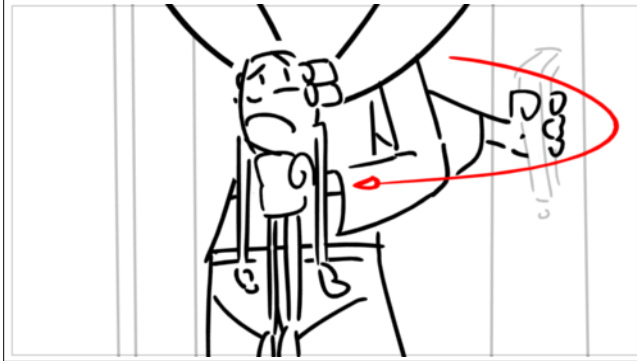

Scene	Duration	Panel	Duration
110	03:10	1	00:11

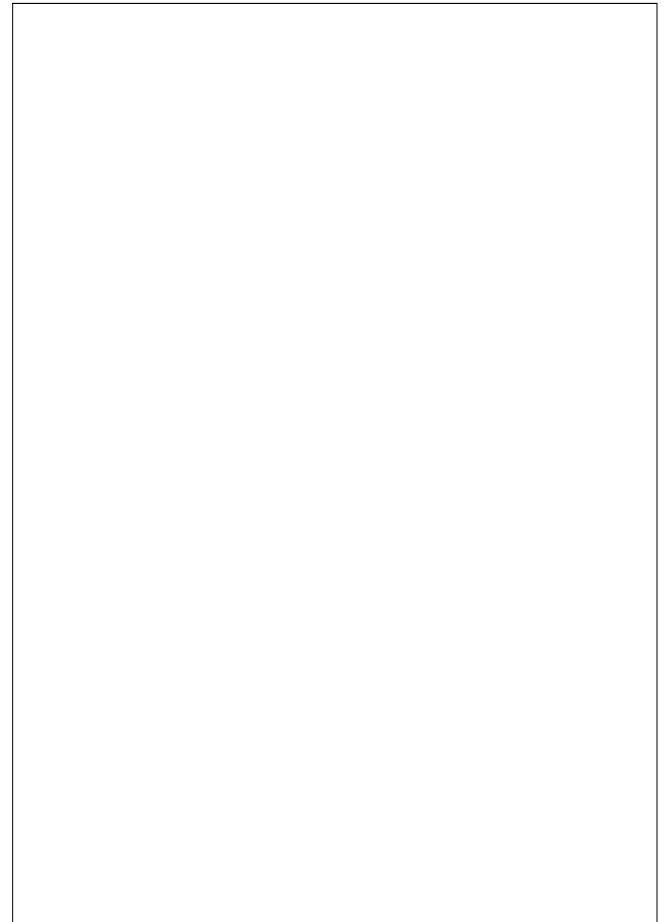
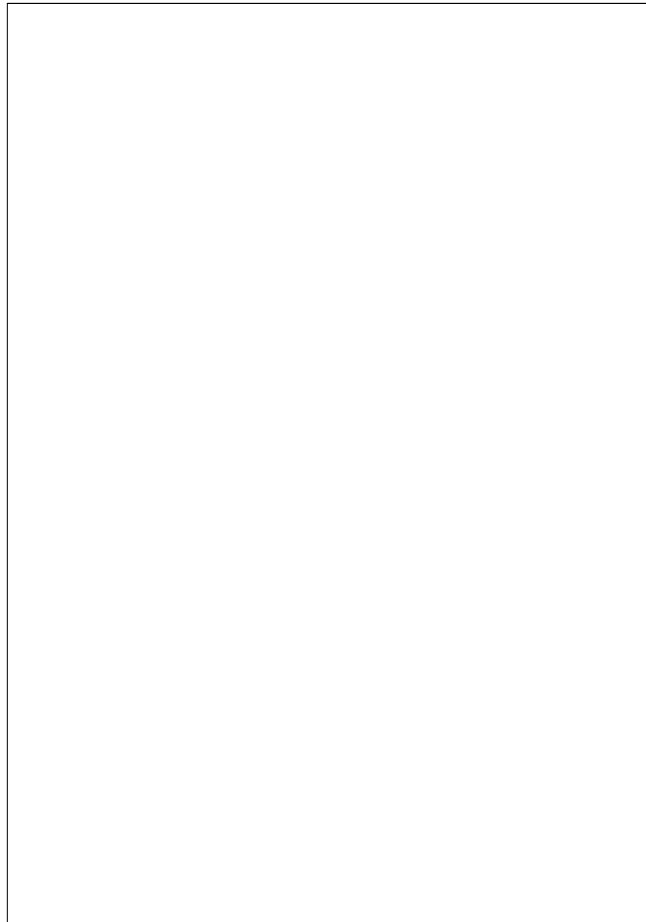
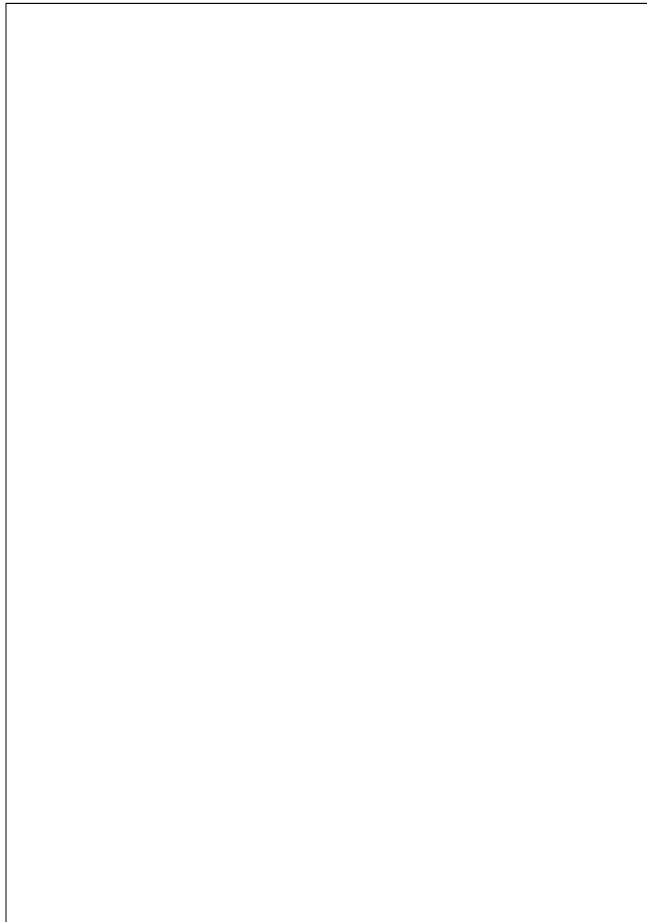



Scene	Duration	Panel	Duration
110	03:10	2	00:20



Scene	Duration	Panel	Duration
110	03:10	3	01:02



Scene	Duration	Panel	Duration
110	03:10	4	01:02

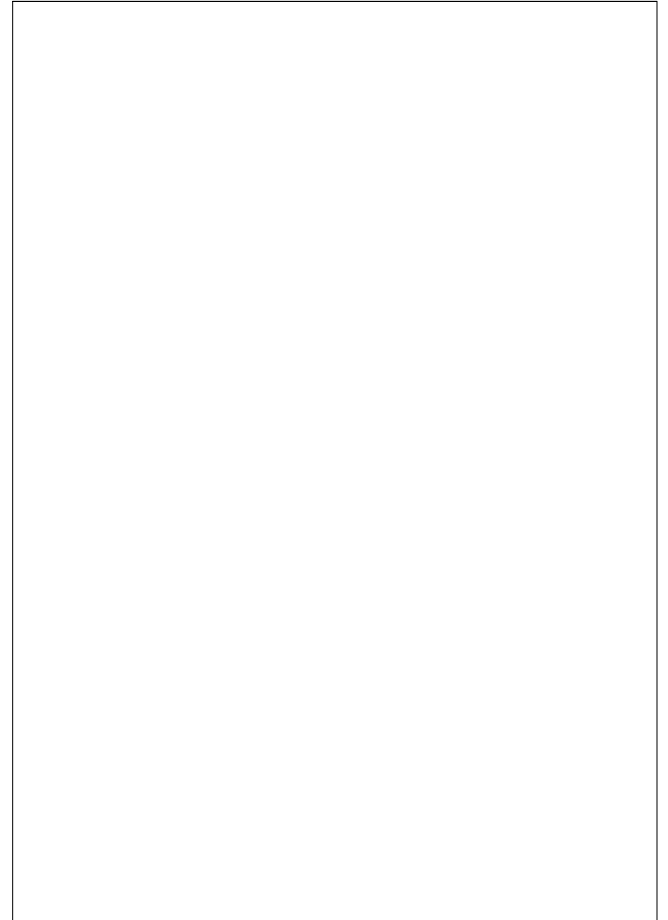
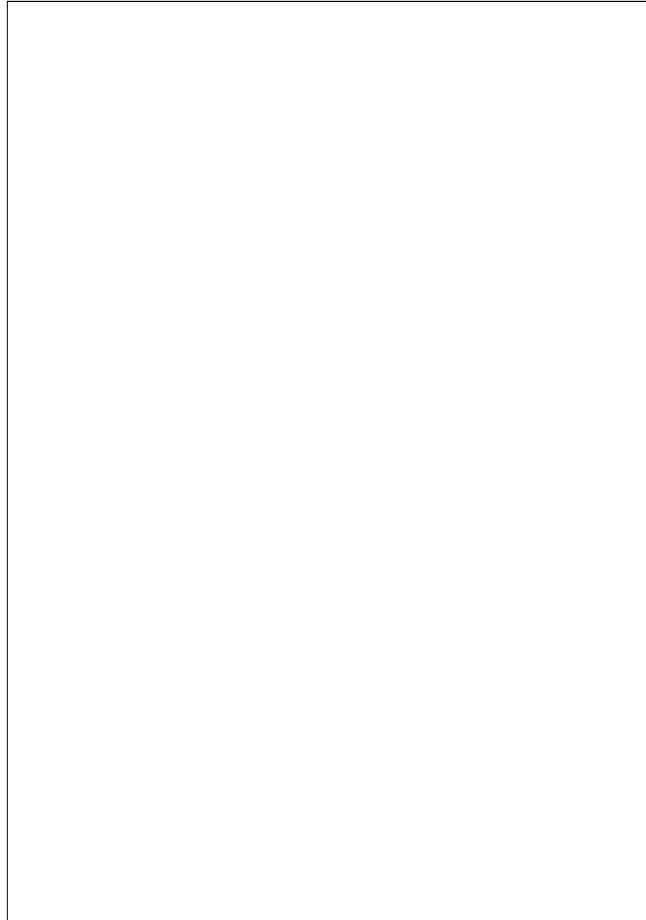
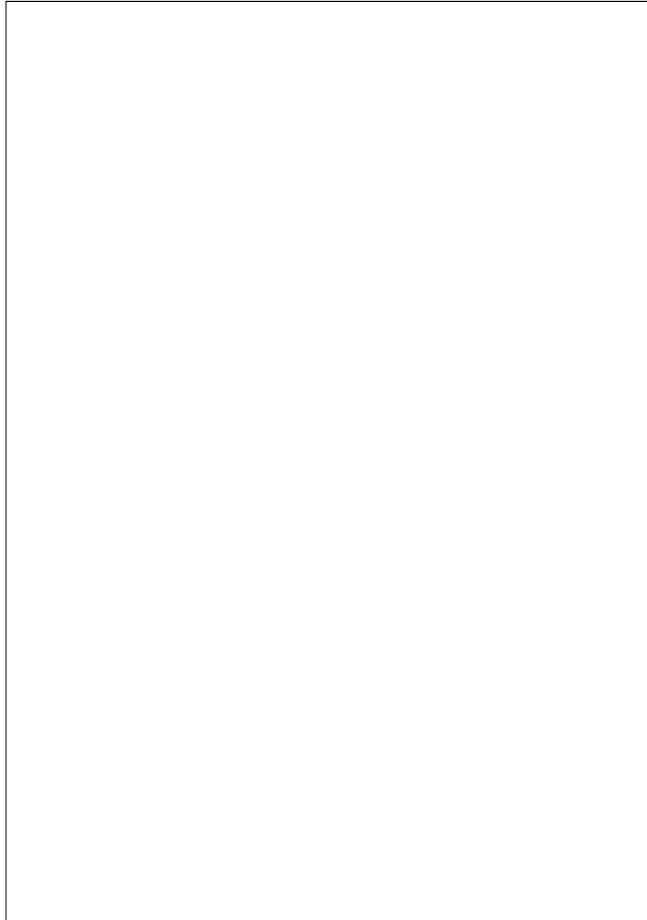

Scene	Duration	Panel	Duration
111	02:15	1	00:12

Scene	Duration	Panel	Duration
111	02:15	2	01:22

Scene	Duration	Panel	Duration
111	02:15	3	00:06

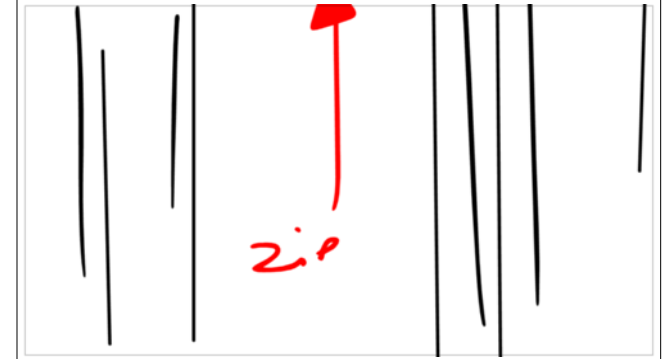

Dialogue
 59. Monseigneur/voix de Cindy
 Bienvenue dans notre modeste demeure,
 cher Ahmed !

Scene	Duration	Panel	Duration
112	02:13	1	01:01



Dialogue
59. Monseigneur/voix de Cindy
cher Ahmed !

Scene	Duration	Panel	Duration
112	02:13	2	01:00



Dialogue
59. Monseigneur/voix de Cindy
cher Ahmed !

Scene	Duration	Panel	Duration
112	02:13	3	00:12





Scene	Duration	Panel	Duration
113	15:19	1	00:08



Dialogue
60. AHMED
Euh...

Scene	Duration	Panel	Duration
113	15:19	2	00:16



Dialogue
60. AHMED
Euh...

Scene	Duration	Panel	Duration
113	15:19	3	01:14



Dialogue
60. AHMED
Euh...



Scene	Duration	Panel	Duration
113	15:19	4	02:04

Scene	Duration	Panel	Duration
113	15:19	5	02:12

NO PANEL

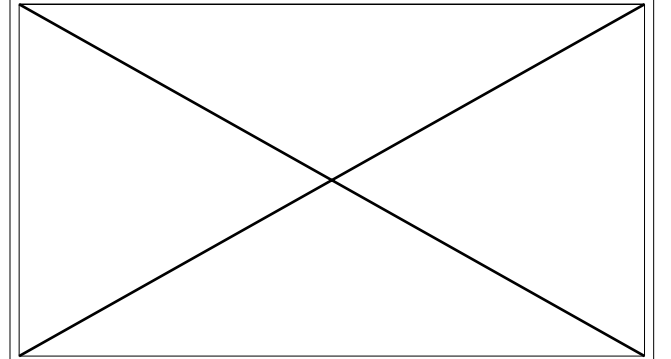

Dialogue
60. AHMED
Dis, ça me tente pas trop d'étudier.

Dialogue
60. AHMED
Tu veux pas plutôt qu'on aille manger
une glace tous les deux ?

Scene	Duration	Panel	Duration
113	15:19	6	00:16

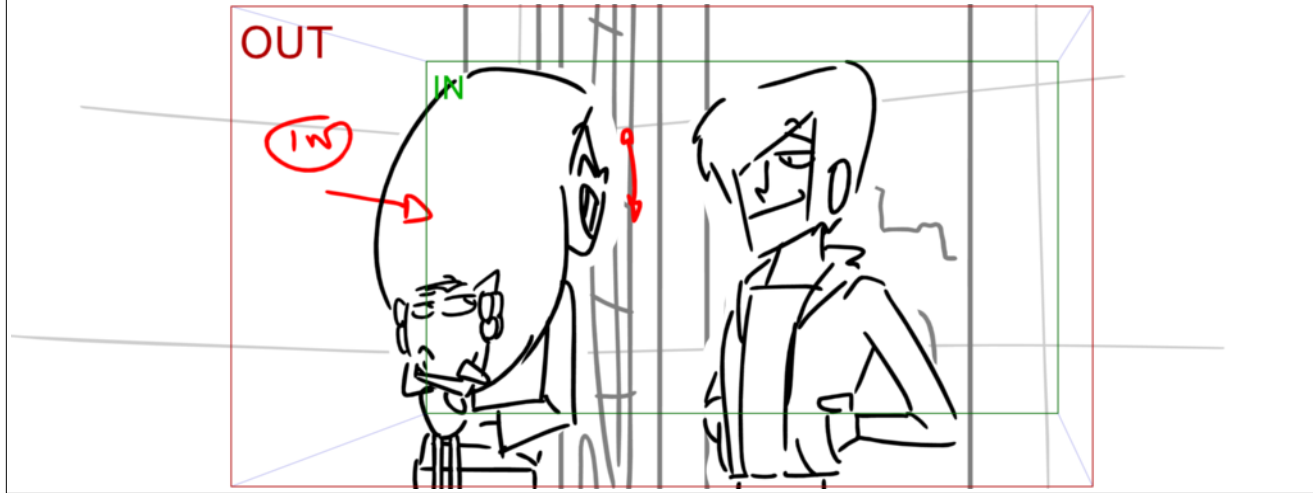

Scene	Duration	Panel	Duration
113	15:19	7	02:04



Dialogue

PU MONSEIGNEUR / VOIX DE CINDY
Non



Scene	Duration	Panel	Duration
113	15:19	8	00:14



Scene	Duration	Panel	Duration
113	15:19	9	01:00



NO PANEL

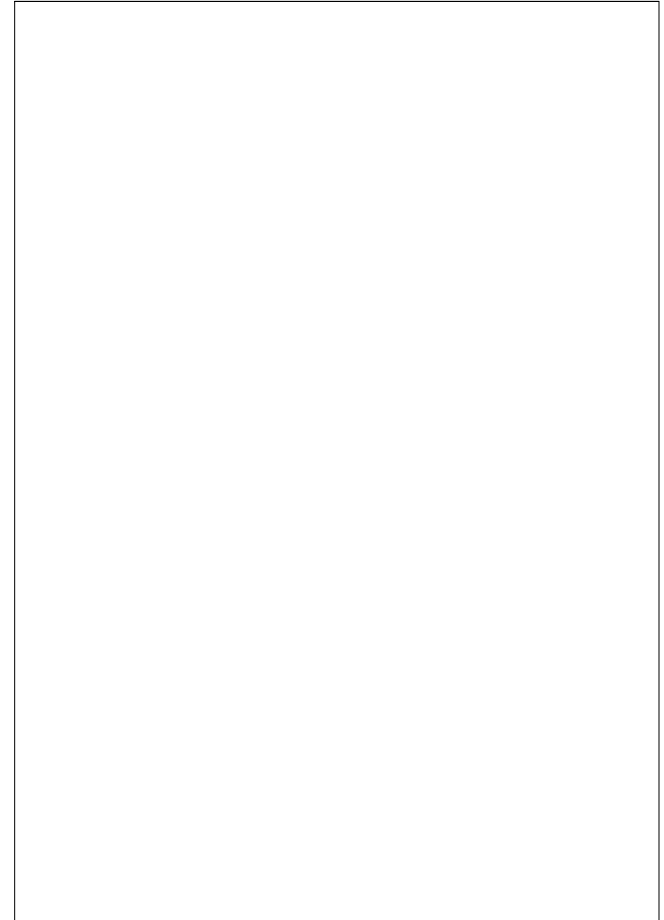
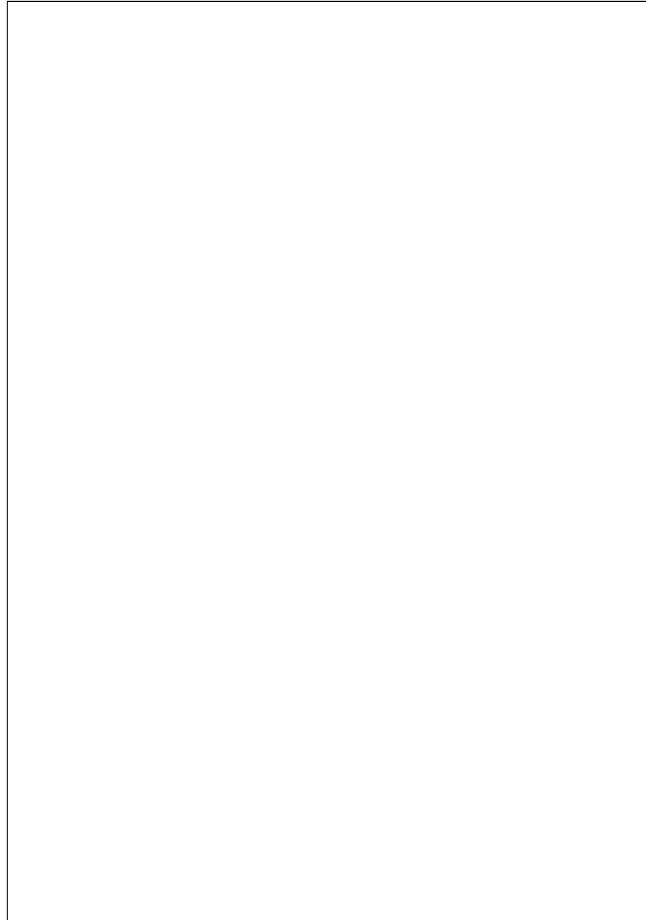
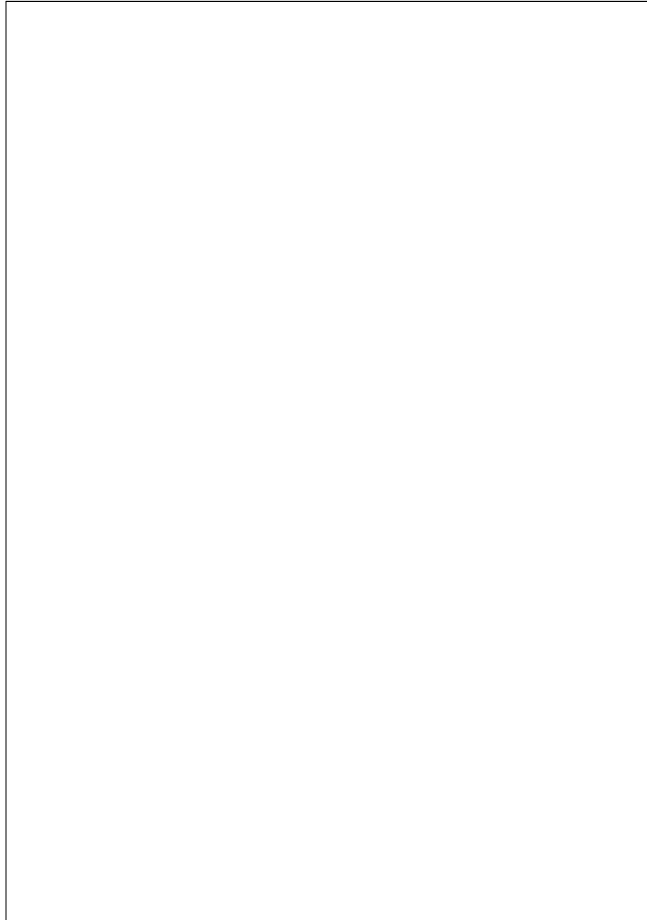
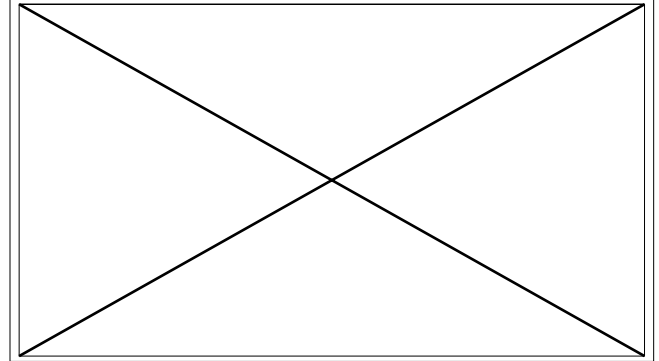



Scene	Duration	Panel	Duration
113	15:19	10	04:06

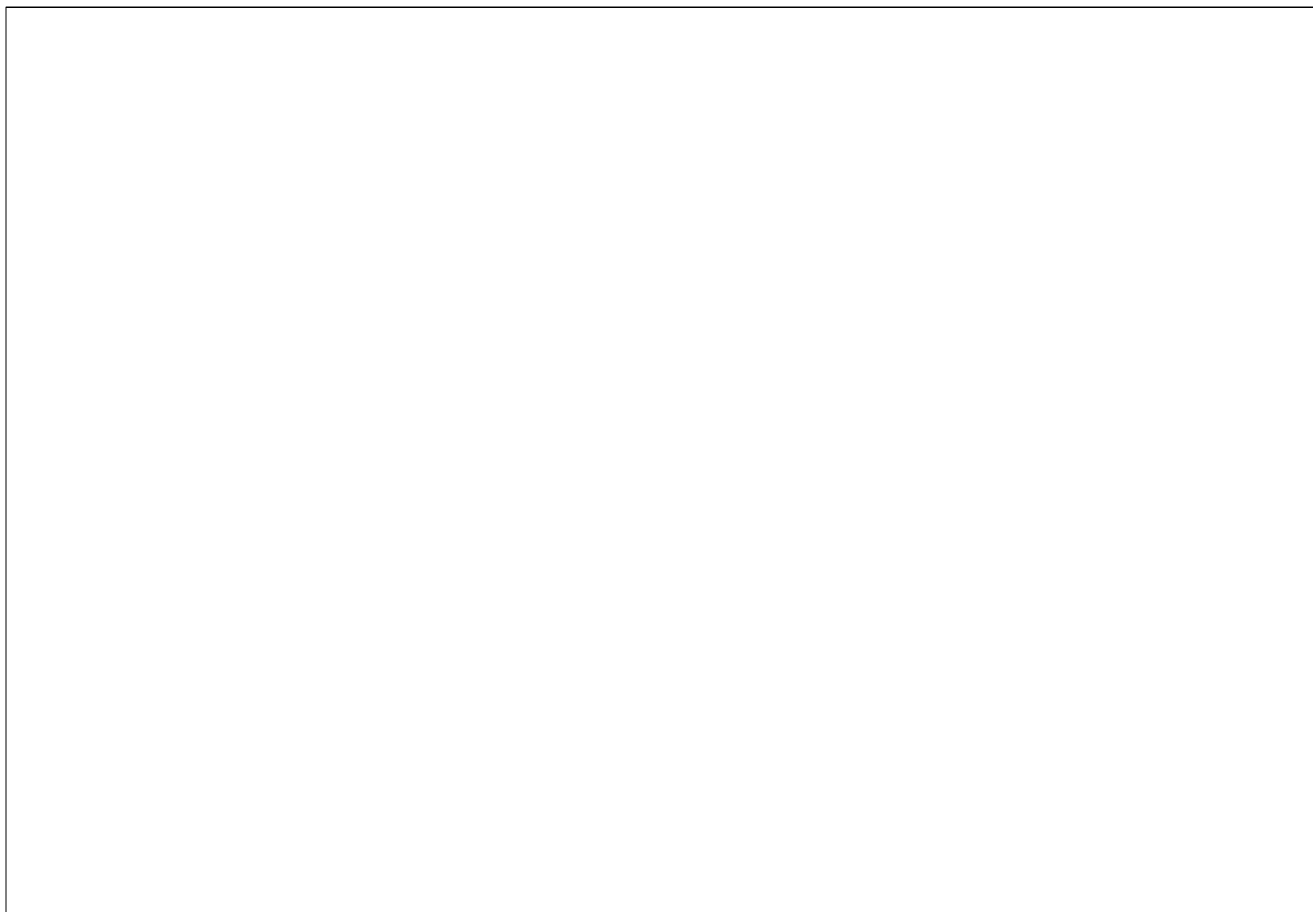
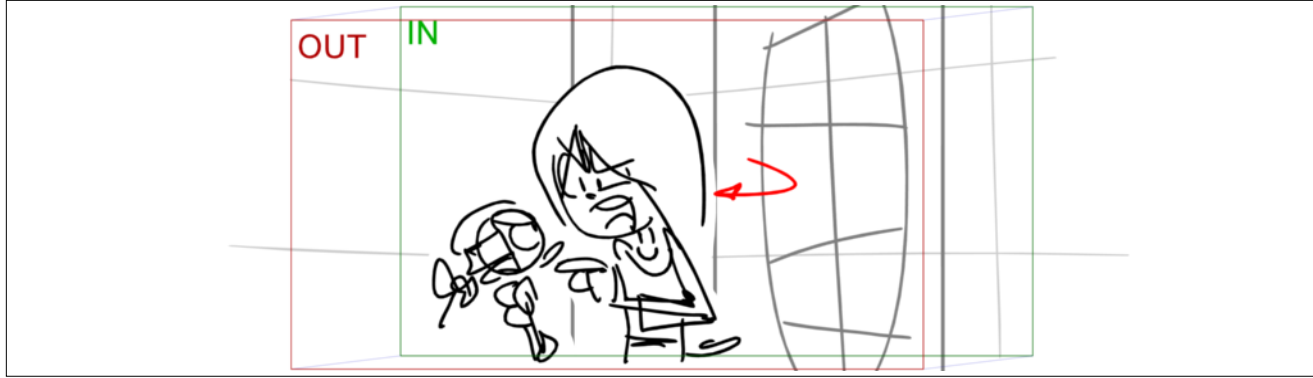

Scene	Duration	Panel	Duration
114	01:00	1	01:00

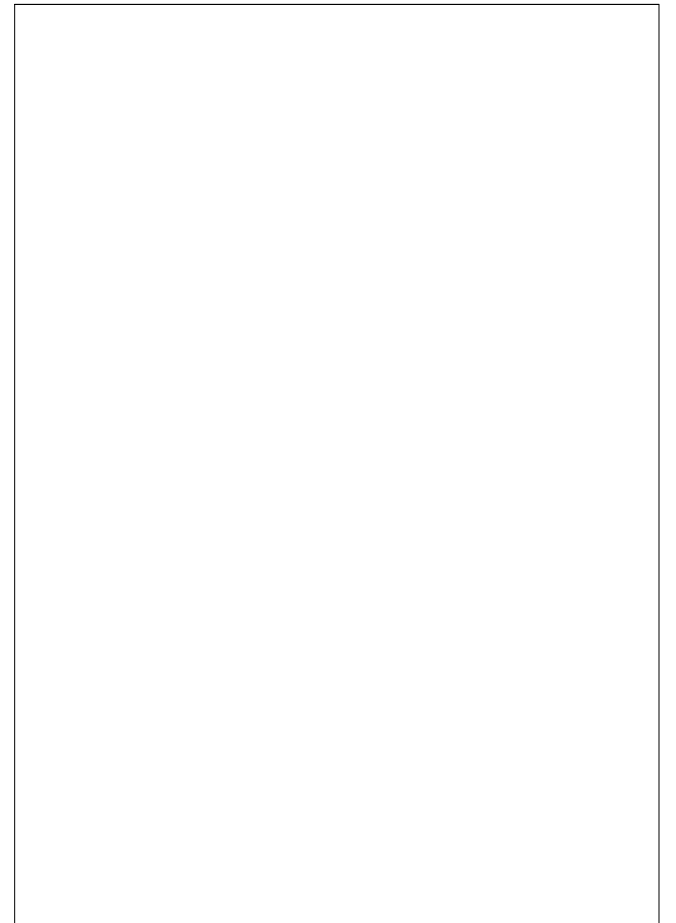



Scene	Duration	Panel	Duration
115	08:23	1	01:00

Scene	Duration	Panel	Duration
115	08:23	2	00:17

Scene	Duration	Panel	Duration
115	08:23	3	00:18

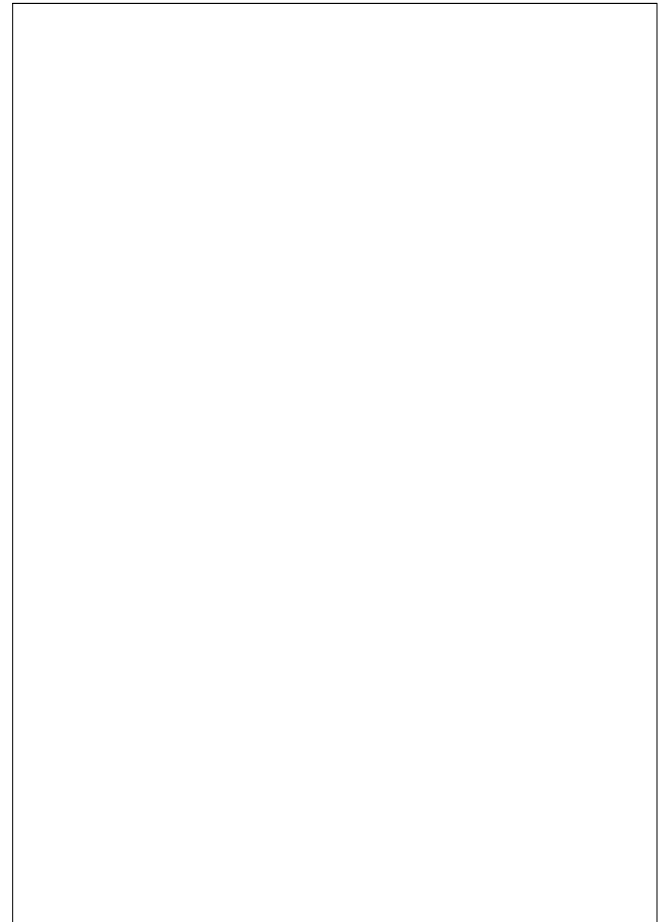
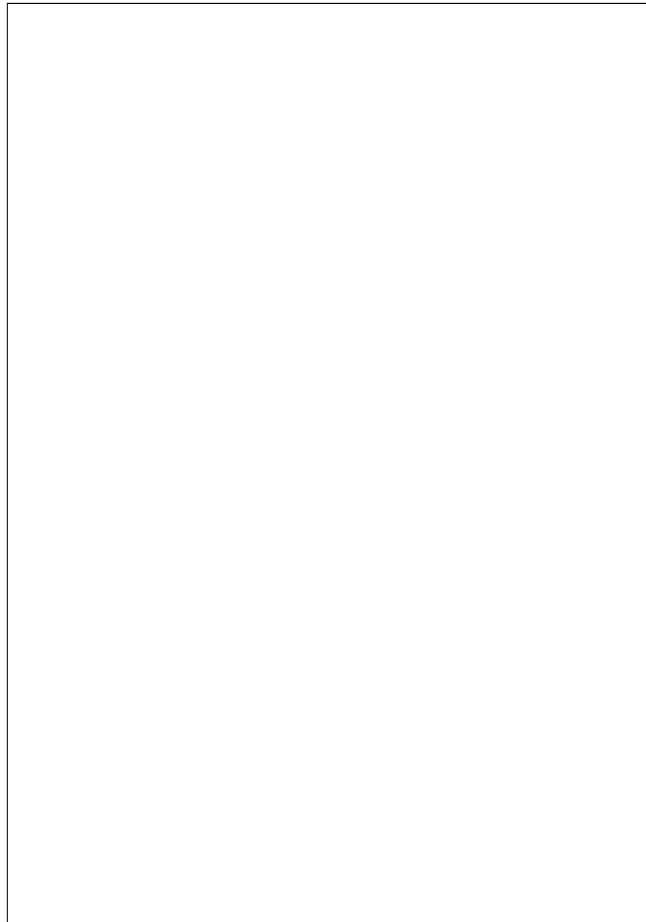
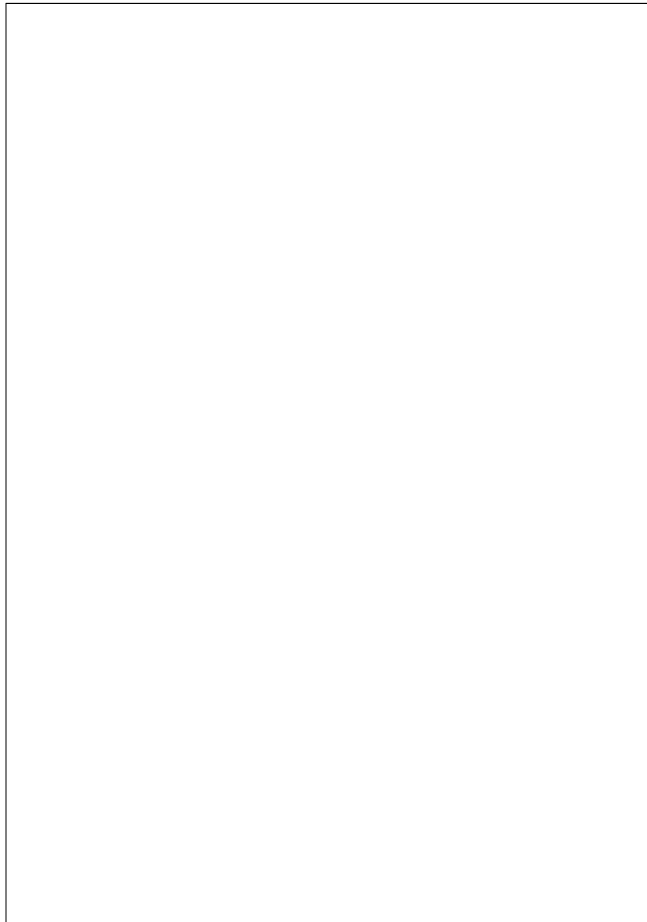
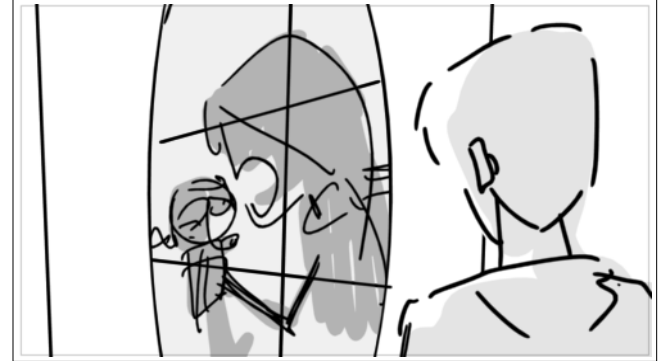
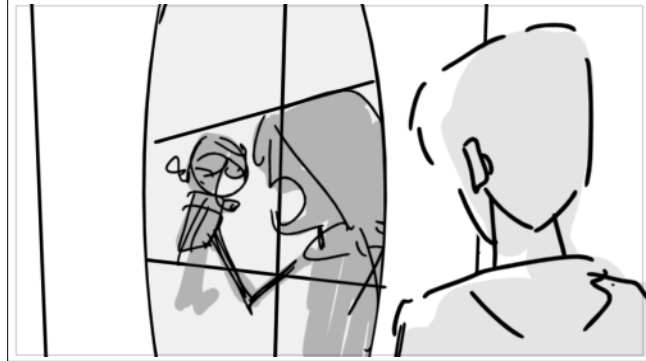
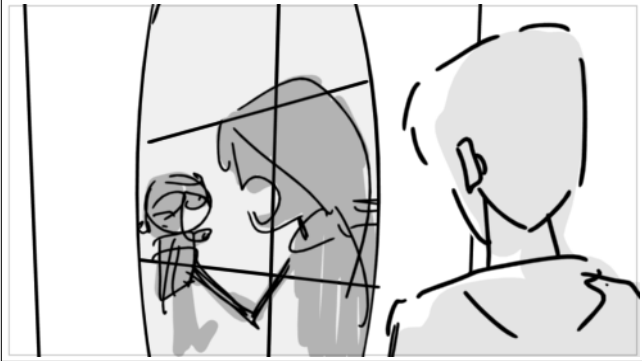

Scene	Duration	Panel	Duration
115	08:23	4	00:15

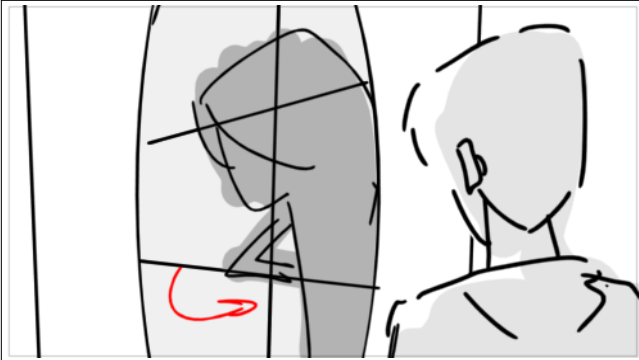

Scene	Duration	Panel	Duration
115	08:23	5	00:12

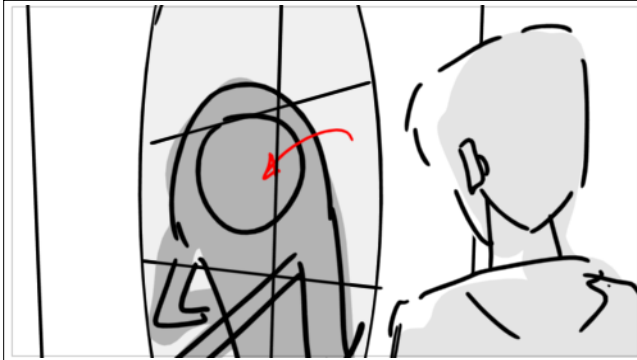

Scene	Duration	Panel	Duration
115	08:23	6	00:22

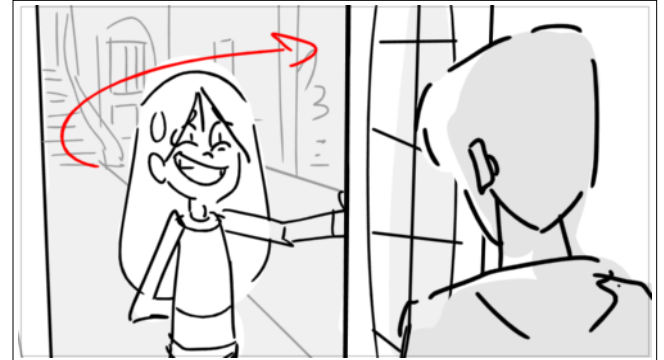

Dialogue

62. AHMED

Tu fais une drôle de tête...

Scene	Duration	Panel	Duration
115	08:23	7	00:19



Scene	Duration	Panel	Duration
115	08:23	8	00:11



Dialogue

63. Monseigneur/voix de Cindy
D'ailleurs,

Scene	Duration	Panel	Duration
115	08:23	9	03:09



Dialogue

63. Monseigneur/voix de Cindy
nous devons nous préparer... Je ne veux pas te chasser, mais...

Scene	Duration	Panel	Duration
116	03:11	1	00:16



Dialogue
64. AHMED
Oh, euh...

Scene	Duration	Panel	Duration
116	03:11	2	01:02



Dialogue
64. AHMED
oui oui bien sûr

Scene	Duration	Panel	Duration
116	03:11	3	01:17



Dialogue
64. AHMED
c'est cool d'être solidaire.

Action Notes

A l'arrière Monseigneur tente de se libérer

Scene	Duration	Panel	Duration
116	03:11	4	00:01



Dialogue
 64. AHMED
 Il a de la chance de t'avoir comme
 grande sœur....

Scene	Duration	Panel	Duration
117	03:00	1	01:00



Scene	Duration	Panel	Duration
117	03:00	2	01:00



Scene	Duration	Panel	Duration
117	03:00	3	01:00

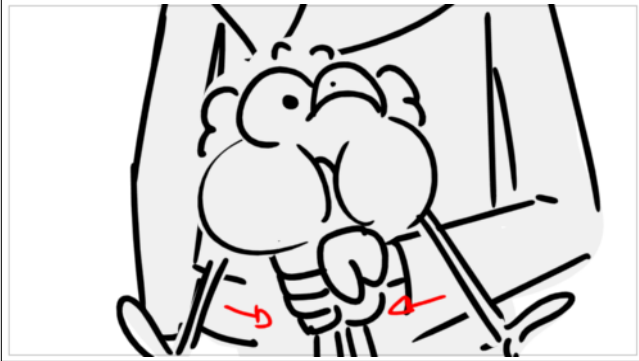

Action Notes

Cindy serre lae poing etouffant monseigneur

Scene	Duration	Panel	Duration
118	08:10	1	00:19



Dialogue

64. AHMED
Il a de la chance de t'avoir comme grande sœur....

Scene	Duration	Panel	Duration
118	08:10	2	01:00

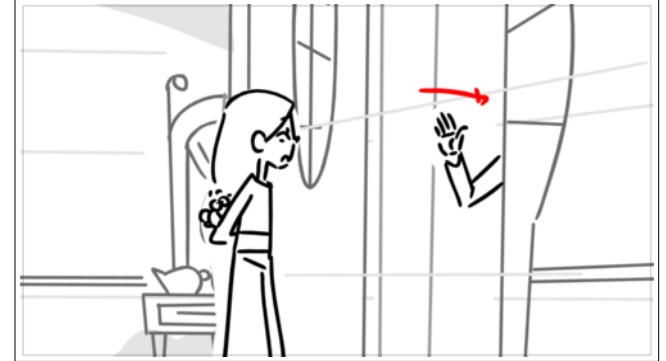

Dialogue

64. AHMED
Eh bien, à demain.



Scene	Duration	Panel	Duration
118	08:10	3	00:19



Scene	Duration	Panel	Duration
118	08:10	4	00:13



Scene	Duration	Panel	Duration
118	08:10	5	00:21

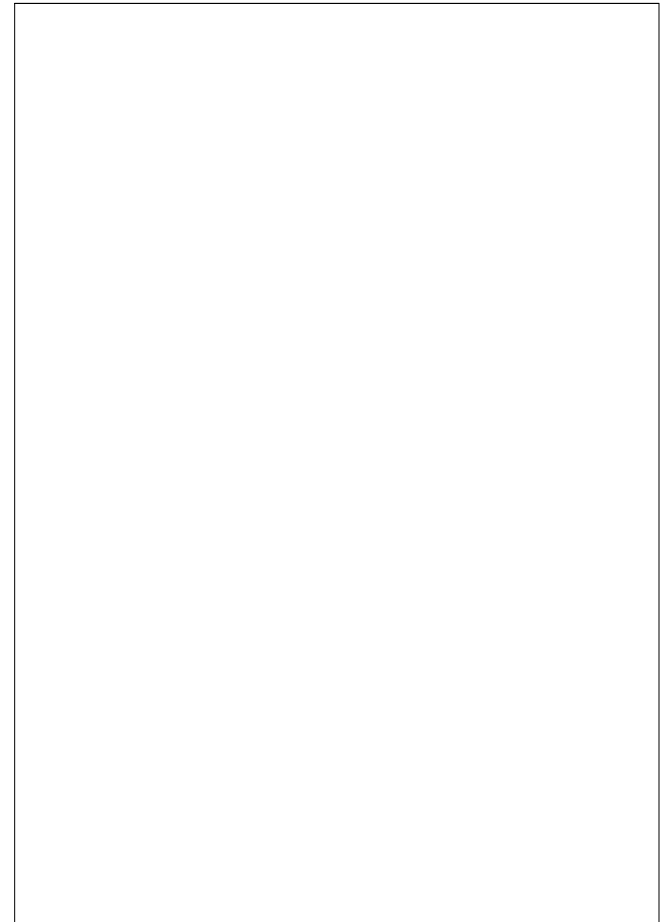
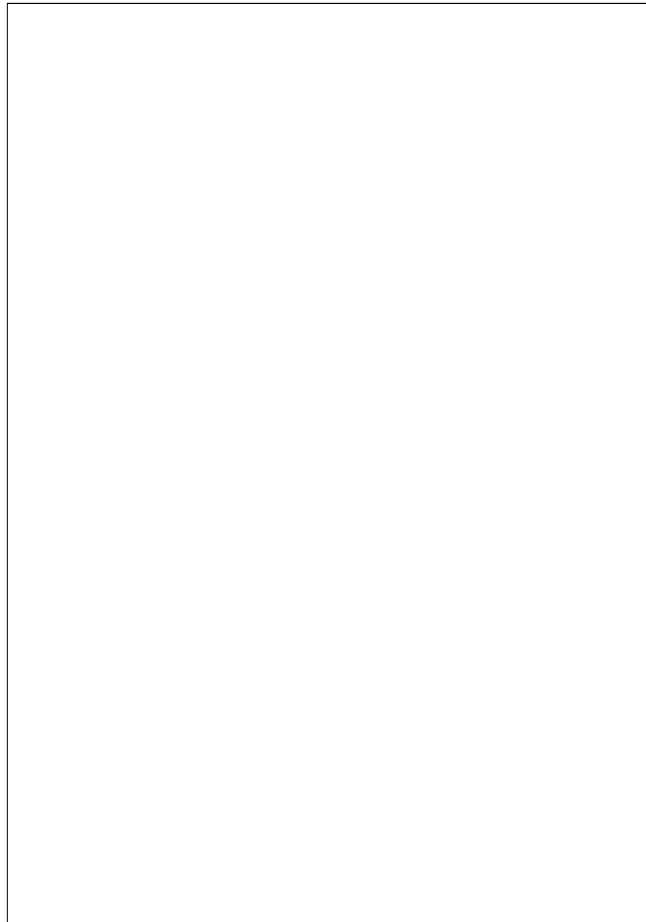
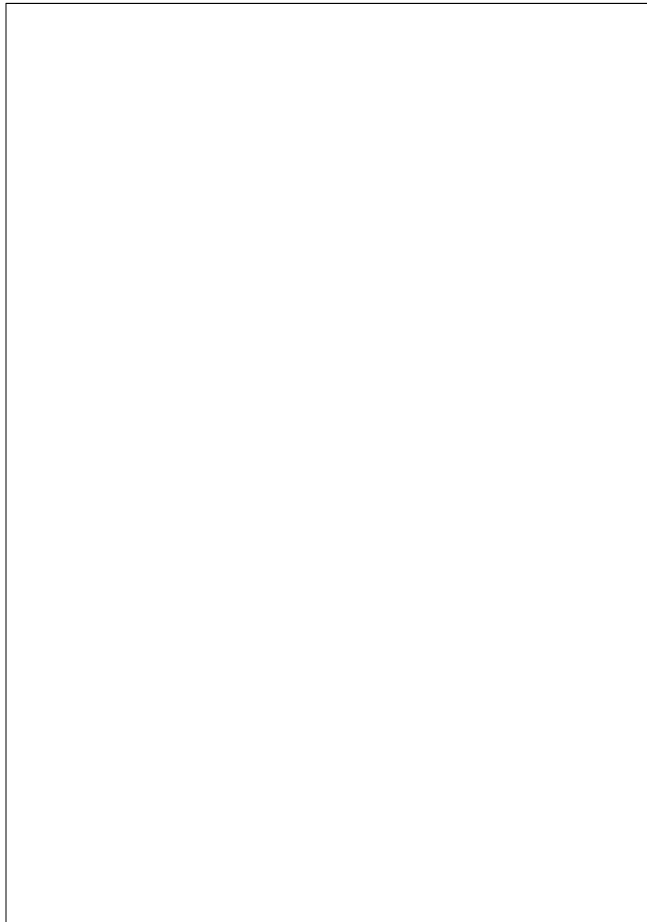

Scene	Duration	Panel	Duration
118	08:10	6	00:17



Dialogue
 65. Cindy/voix de Monseigneur
 Grrrrrrrrrrrrrrrrrr !

Scene	Duration	Panel	Duration
118	08:10	7	00:17



Dialogue
 65. Cindy/voix de Monseigneur
 Grrrrrrrrrrrrrrrrrr !

Scene	Duration	Panel	Duration
118	08:10	8	00:07



Dialogue
 66. Cindy/voix de Monseigneur
 Espèce de grenouille décérébrée !!!

Scene	Duration	Panel	Duration
118	08:10	9	02:05



Dialogue
 66. Cindy/voix de Monseigneur
 Espèce de grenouille décérébrée !!!

Scene	Duration	Panel	Duration
118	08:10	10	00:17



Scene	Duration	Panel	Duration
119	03:00	1	01:00



Action Notes
 16. INT. ECOLE/SALLE DE SPECTACLE -
 JOUR



Scene	Duration	Panel	Duration
119	03:00	2	01:00

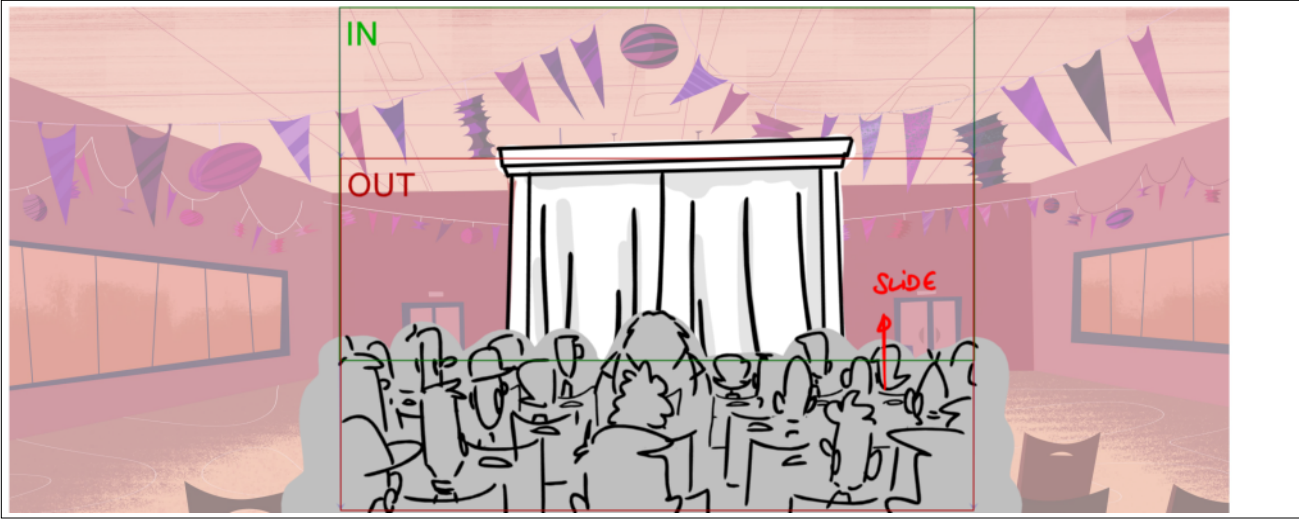

Scene	Duration	Panel	Duration
119	03:00	3	01:00

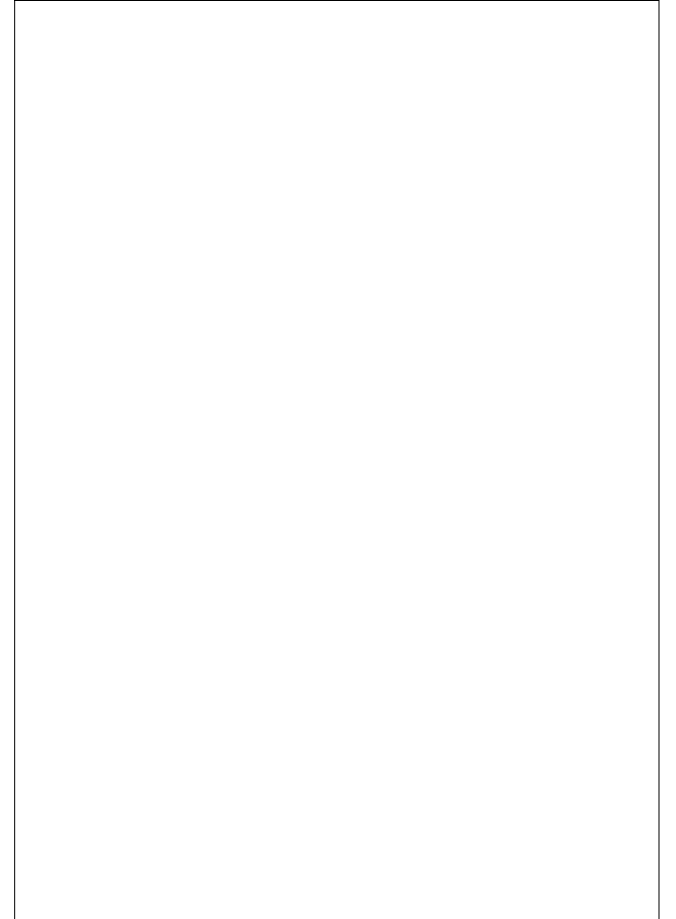



Scene	Duration	Panel	Duration
120	02:00	1	01:00



Scene	Duration	Panel	Duration
120	02:00	2	01:00



Action Notes

Les lumières se tamisent

Scene	Duration	Panel	Duration
121	06:04	1	00:13

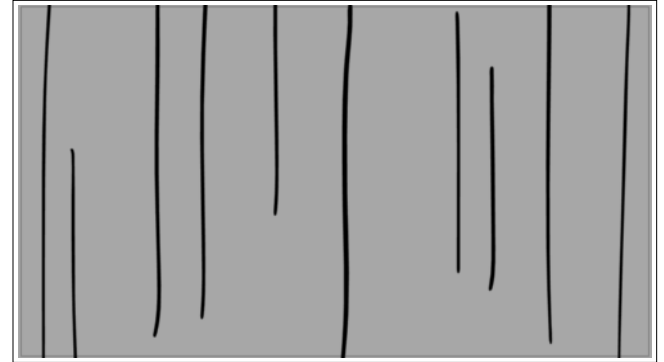

Scene	Duration	Panel	Duration
121	06:04	2	00:14

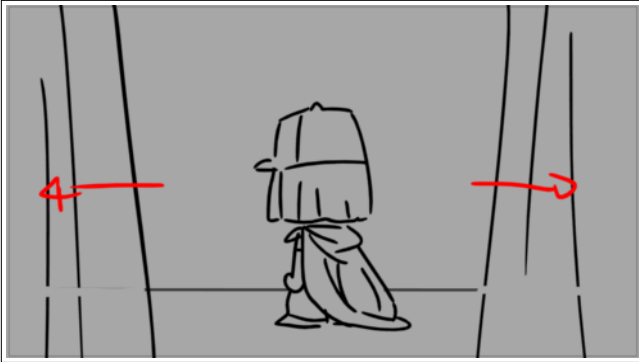

Scene	Duration	Panel	Duration
121	06:04	3	01:11

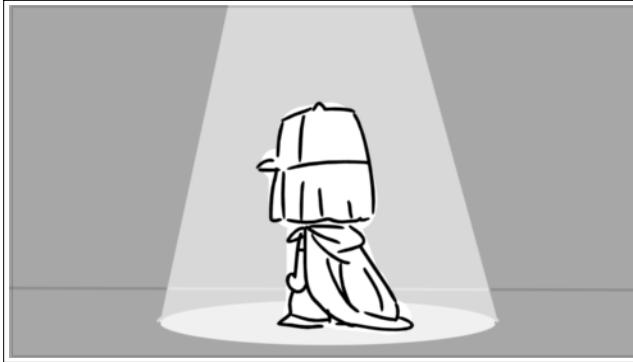

Action Notes

Tom déguisé en dark vador apparait de dos

Scene	Duration	Panel	Duration
121	06:04	4	00:13

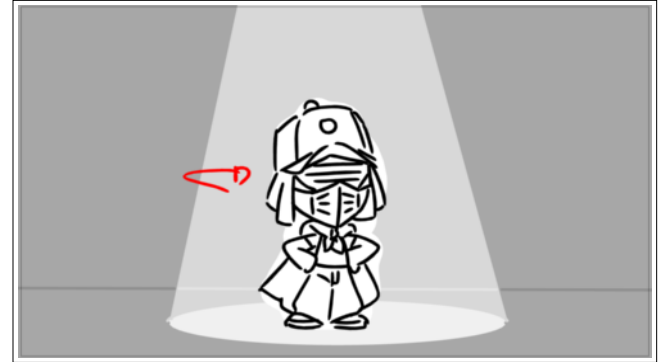

Scene	Duration	Panel	Duration
121	06:04	5	01:10



Dialogue

68. Tom/VOIX de grégor (dynamique)
Il y a bien longtemps,

Scene	Duration	Panel	Duration
121	06:04	6	01:18



Dialogue

68. Tom/VOIX de grégor (dynamique)
Il y a bien longtemps,

Scene	Duration	Panel	Duration
122	04:10	1	02:05



Dialogue

68. Tom/VOIX de grégor (dynamique)
dans une galaxie lointaine,

Scene	Duration	Panel	Duration
122	04:10	2	02:05



Dialogue

68. Tom/VOIX de grégor (dynamique)
dans une galaxie lointaine,

Scene	Duration	Panel	Duration
123	06:19	1	01:06

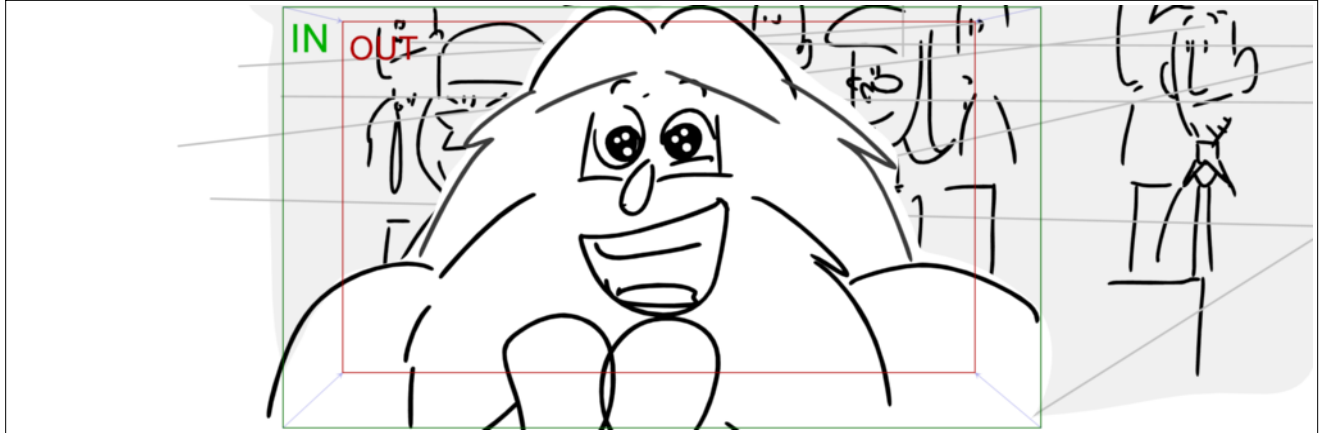

Dialogue

69. GREGOR/VOIX de TOM
C'est mon fils !



Scene	Duration	Panel	Duration
123	06:19	2	00:10



Scene	Duration	Panel	Duration
123	06:19	3	00:10

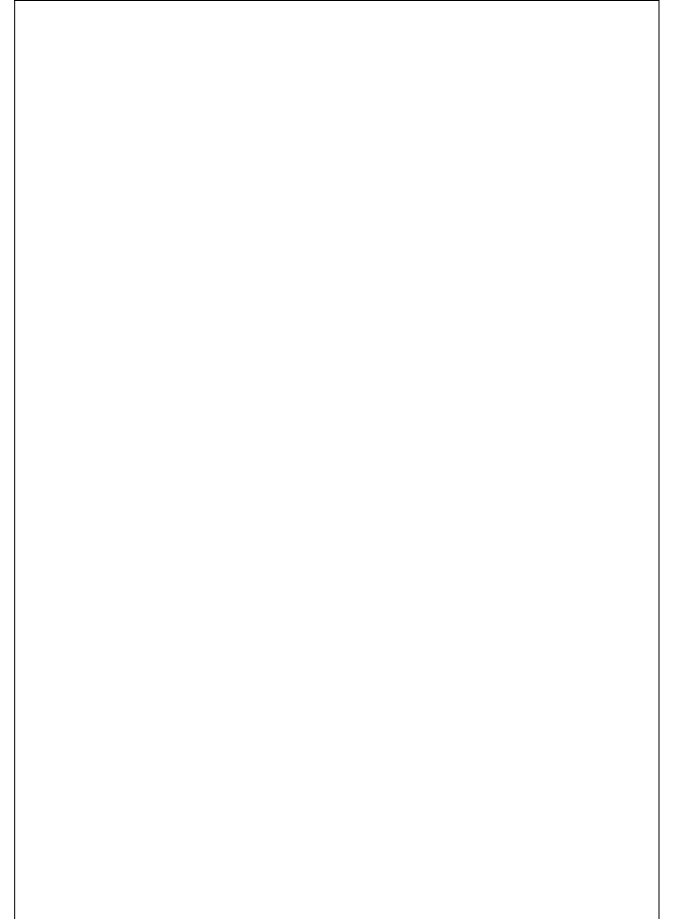

Scene	Duration	Panel	Duration
123	06:19	4	00:09



Dialogue

70. PERE DE Victor (moqueur, parodiant la voix de Tom)
 Ahahahah !

Scene	Duration	Panel	Duration
123	06:19	5	00:22

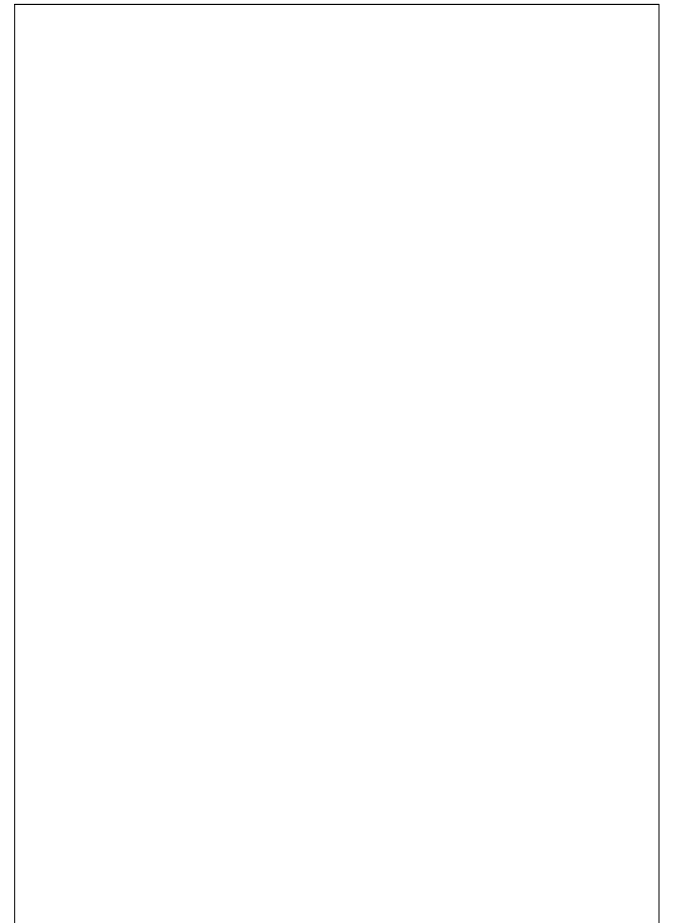

Scene	Duration	Panel	Duration
123	06:19	6	01:00



Dialogue

70. PERE DE Victor (moqueur, parodiant la voix de Tom)
Ahahahah !

Scene	Duration	Panel	Duration
123	06:19	7	00:20



Dialogue

70. PERE DE Victor (moqueur, parodiant la voix de Tom)
« C'est mon fils ! » !

Scene	Duration	Panel	Duration
123	06:19	8	01:17



Dialogue

70. PERE DE Victor (moqueur, parodiant la voix de Tom)
Ahahahah !

Scene	Duration	Panel	Duration
124	01:00	1	01:00

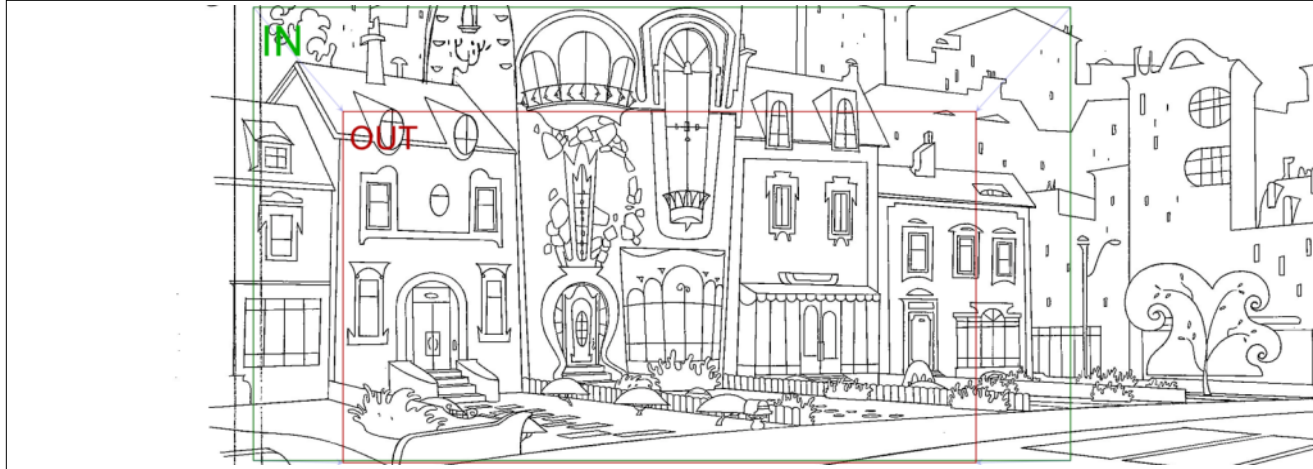

Dialogue

67. Monseigneur /voix de Cindy
 Ahhhhh, ahhhha, nonnnnnn ! Au secours ! A l'aide !

Scene	Duration	Panel	Duration
125	03:03	1	00:08



Dialogue

67. Monseigneur /voix de Cindy
 Ahhhhh, ahhhha, nonnnnnn ! Au secours !
 A l'aide !

Scene	Duration	Panel	Duration
125	03:03	2	00:07

Scene	Duration	Panel	Duration
125	03:03	3	00:07

Scene	Duration	Panel	Duration
125	03:03	4	00:07



Dialogue
 67. Monseigneur /voix de Cindy
 Ahhhhh, ahhhha, nonnnnnn ! Au secours !
 A l'aide !

Dialogue
 67. Monseigneur /voix de Cindy
 Ahhhhh, ahhhha, nonnnnnn ! Au secours !
 A l'aide !

Dialogue
 67. Monseigneur /voix de Cindy
 Ahhhhh, ahhhha, nonnnnnn ! Au secours !
 A l'aide !

Scene	Duration	Panel	Duration
125	03:03	5	00:07

Scene	Duration	Panel	Duration
125	03:03	6	00:07

Scene	Duration	Panel	Duration
125	03:03	7	00:07



Dialogue
 67. Monseigneur /voix de Cindy
 Ahhhhh, ahhhha, nonnnnnn ! Au secours !
 A l'aide !

Dialogue
 67. Monseigneur /voix de Cindy
 Ahhhhh, ahhhha, nonnnnnn ! Au secours !
 A l'aide !

Dialogue
 67. Monseigneur /voix de Cindy
 Ahhhhh, ahhhha, nonnnnnn ! Au secours !
 A l'aide !

Scene	Duration	Panel	Duration
125	03:03	8	00:07

Scene	Duration	Panel	Duration
125	03:03	9	00:07

Scene	Duration	Panel	Duration
125	03:03	10	00:07



Dialogue

67. Monseigneur /voix de Cindy
 Ahhhhh, ahhhha, nonnnnnn ! Au secours !
 A l'aide !

Dialogue

67. Monseigneur /voix de Cindy
 Ahhhhh, ahhhha, nonnnnnn ! Au secours !
 A l'aide !

Dialogue

67. Monseigneur /voix de Cindy
 Ahhhhh, ahhhha, nonnnnnn ! Au secours !
 A l'aide !

Scene	Duration	Panel	Duration
125	03:03	11	00:07

Scene	Duration	Panel	Duration
126	02:04	1	00:06

Scene	Duration	Panel	Duration
126	02:04	2	00:05

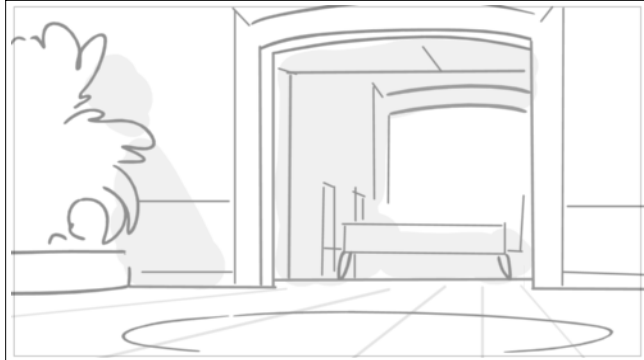

Dialogue
 67. Monseigneur /voix de Cindy
 Ahhhhh, ahhhha, nonnnnnn ! Au secours !
 A l'aide !



Scene	Duration	Panel	Duration
126	02:04	3	00:09

Scene	Duration	Panel	Duration
126	02:04	4	00:19

Scene	Duration	Panel	Duration
126	02:04	5	00:08

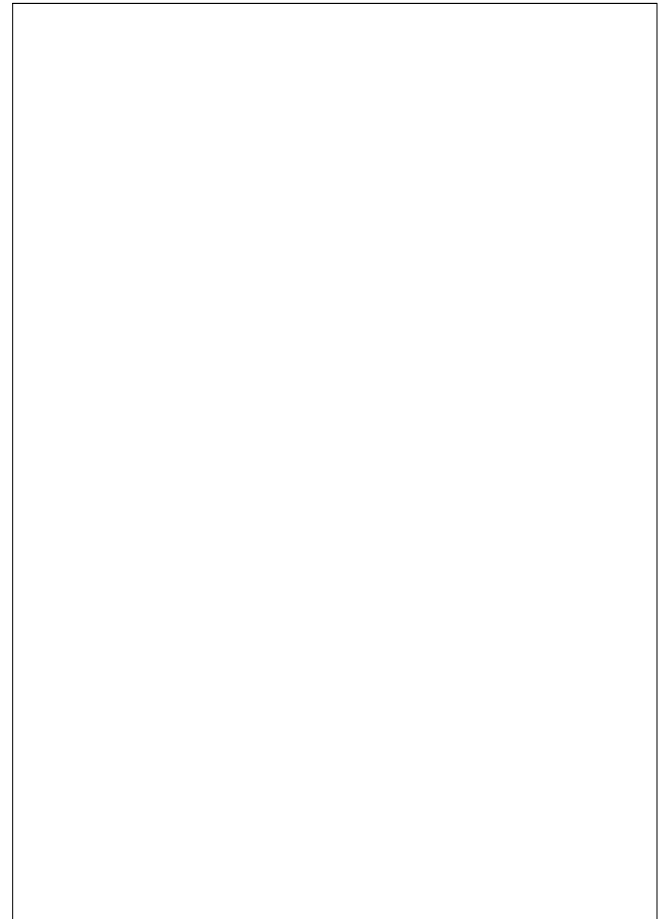
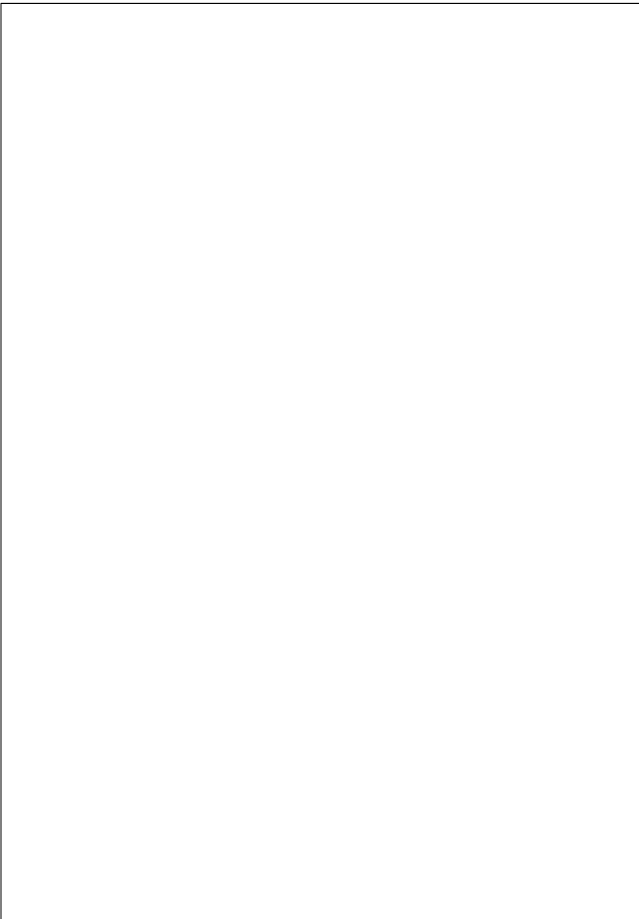
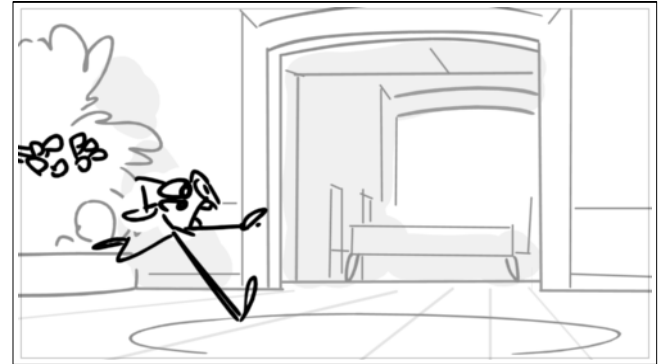
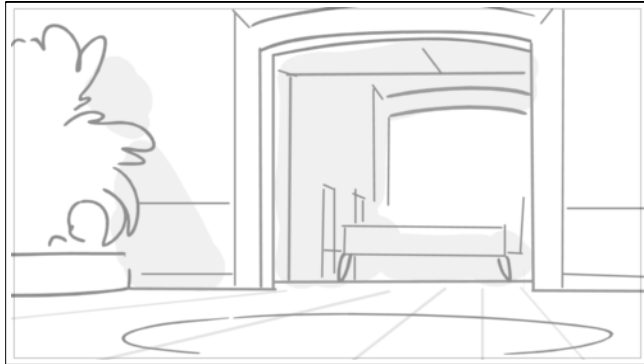
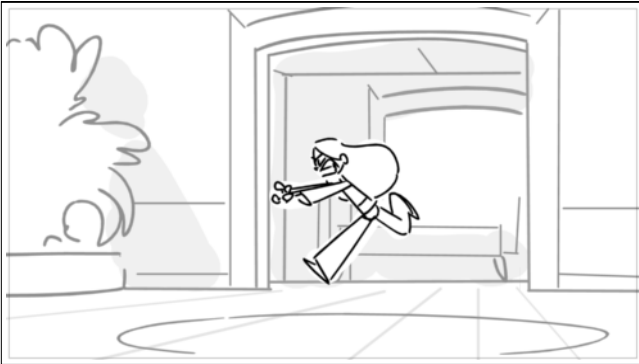



Scene	Duration	Panel	Duration
126	02:04	6	00:07

Scene	Duration	Panel	Duration
127	00:20	1	00:05

NO PANEL

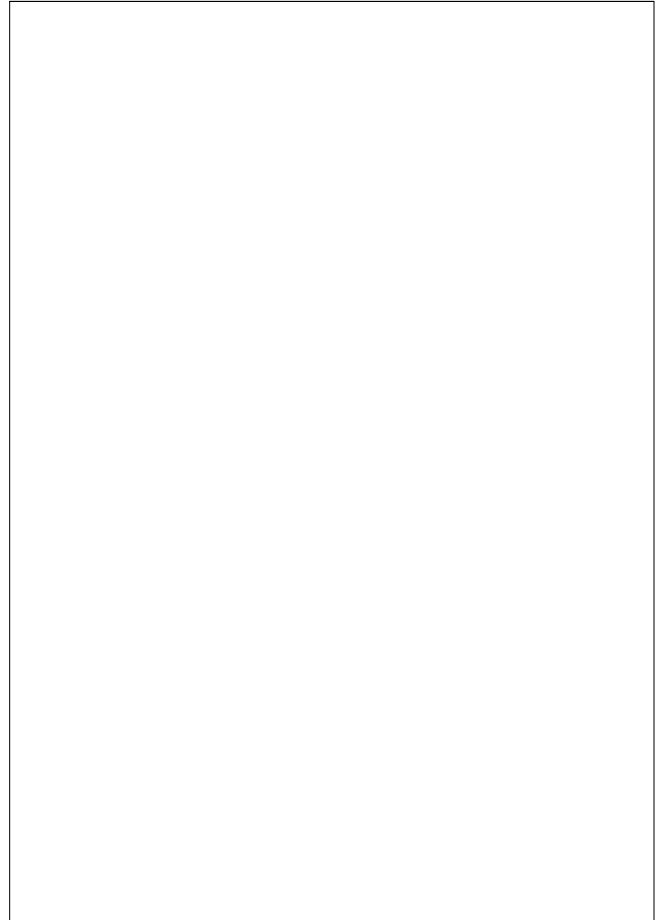
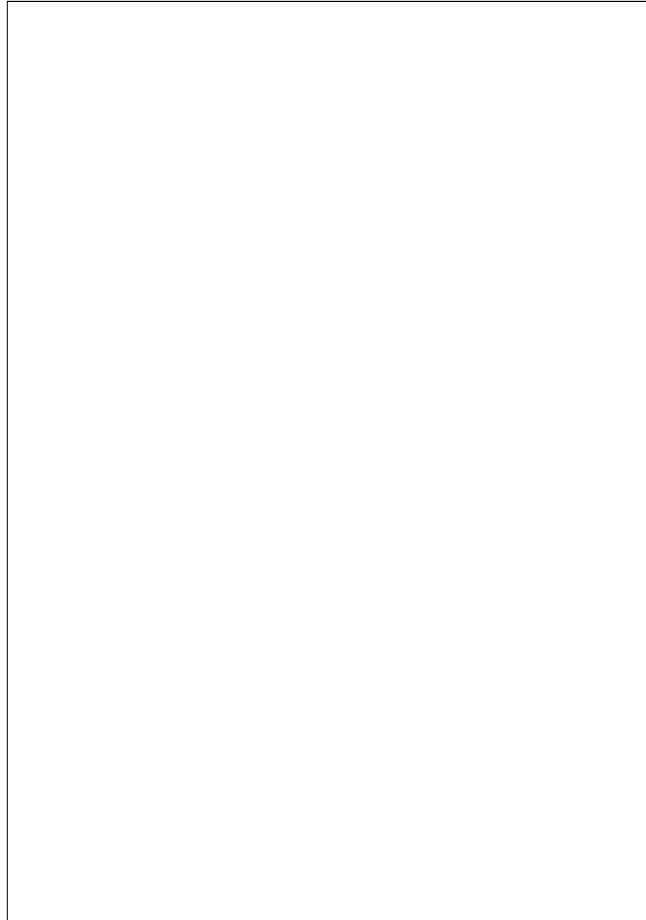
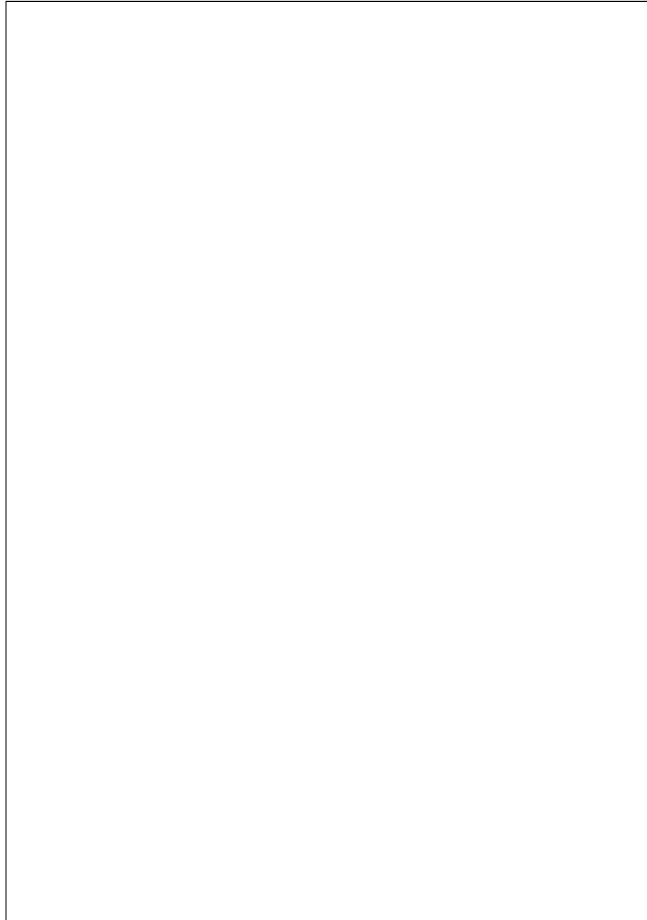
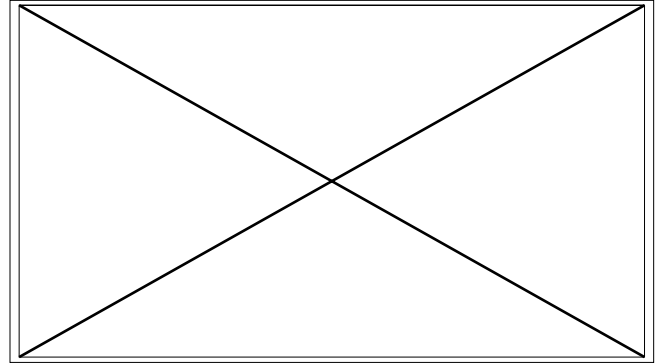



Scene	Duration	Panel	Duration
127	00:20	2	00:15

Scene	Duration	Panel	Duration
128	07:04	1	00:08

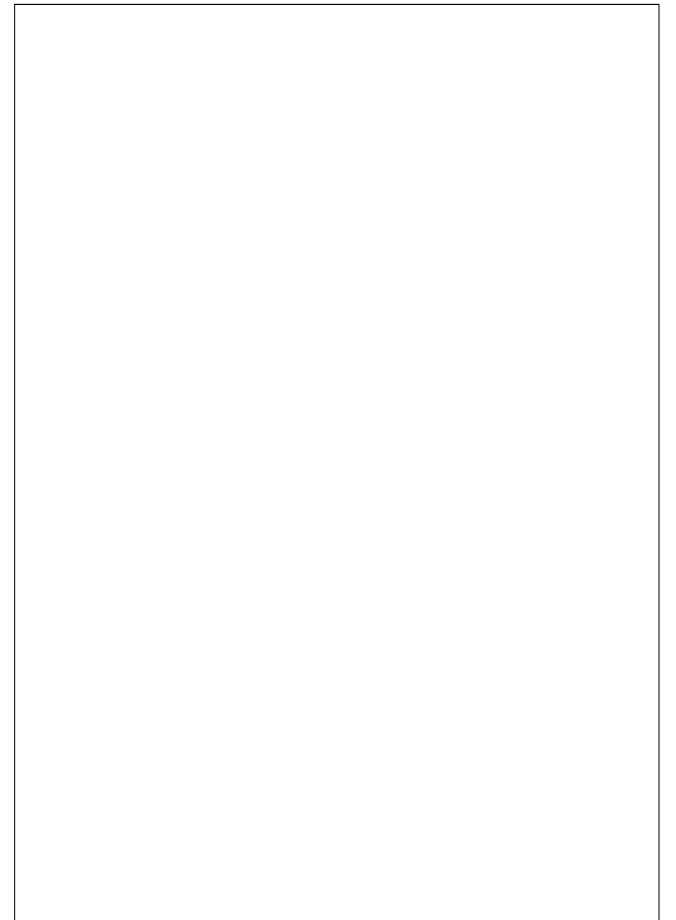
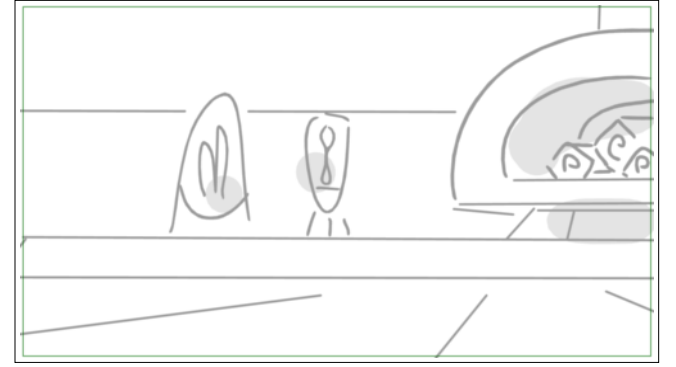
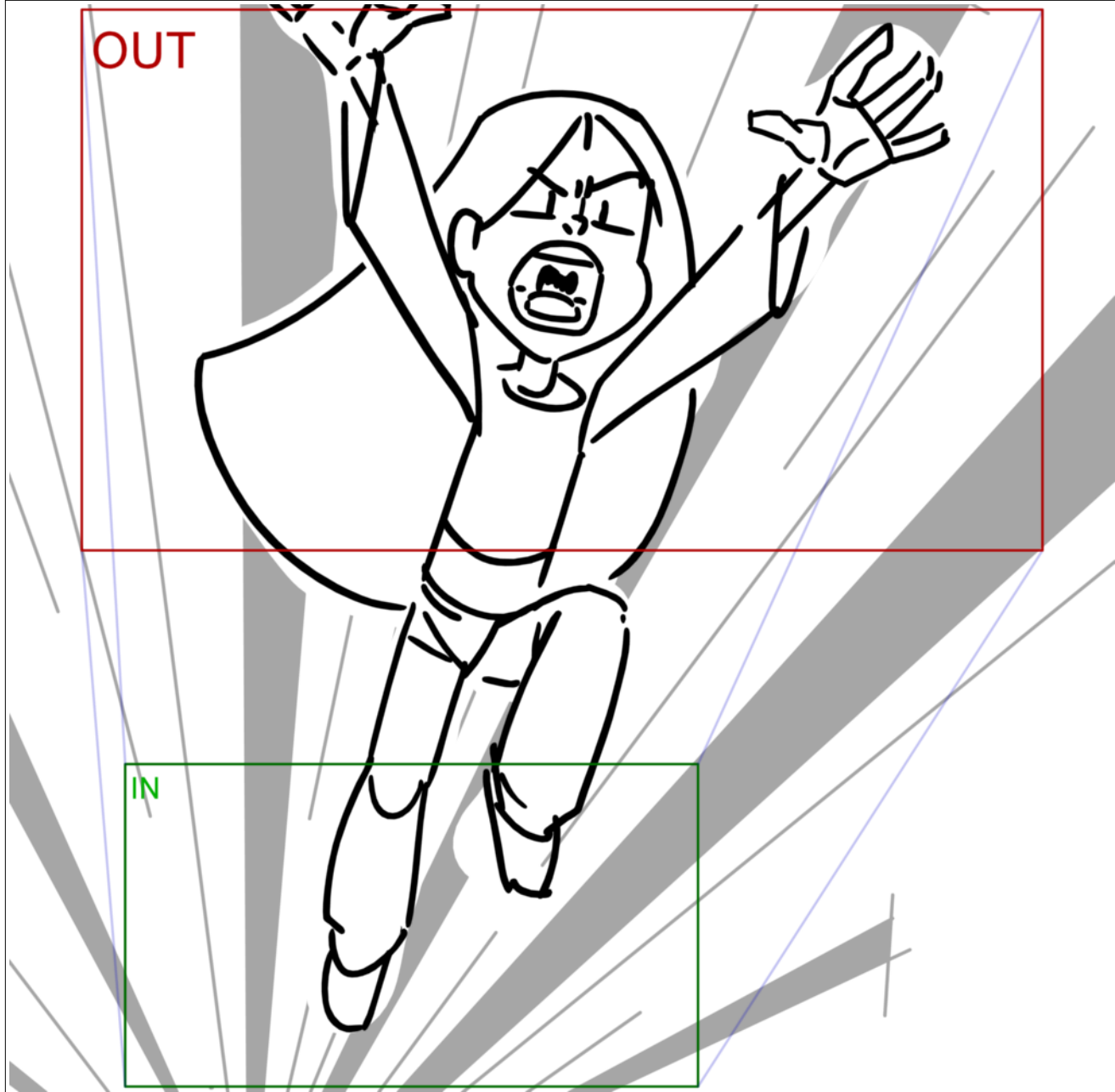



Scene	Duration	Panel	Duration
128	07:04	2	00:12



Scene	Duration	Panel	Duration
128	07:04	3	00:06



Scene	Duration	Panel	Duration
128	07:04	4	00:07

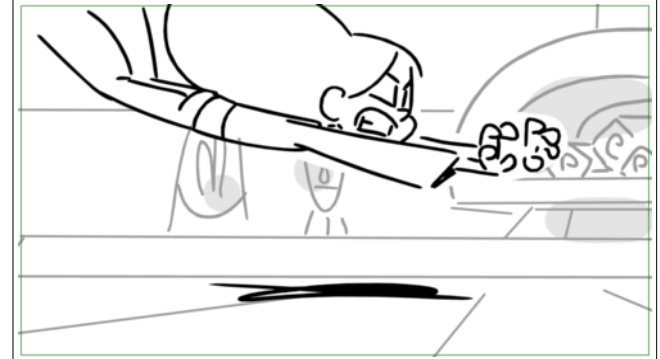

Action Notes

Cindy IN OUT en vol plané



Scene	Duration	Panel	Duration
128	07:04	5	00:22

Scene	Duration	Panel	Duration
128	07:04	6	01:05

Scene	Duration	Panel	Duration
128	07:04	7	00:12

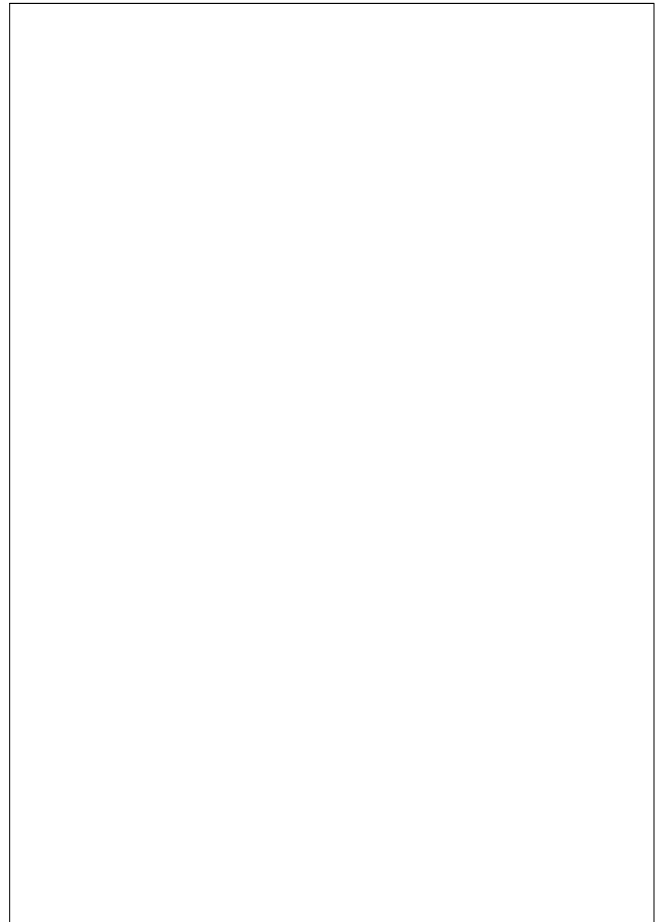
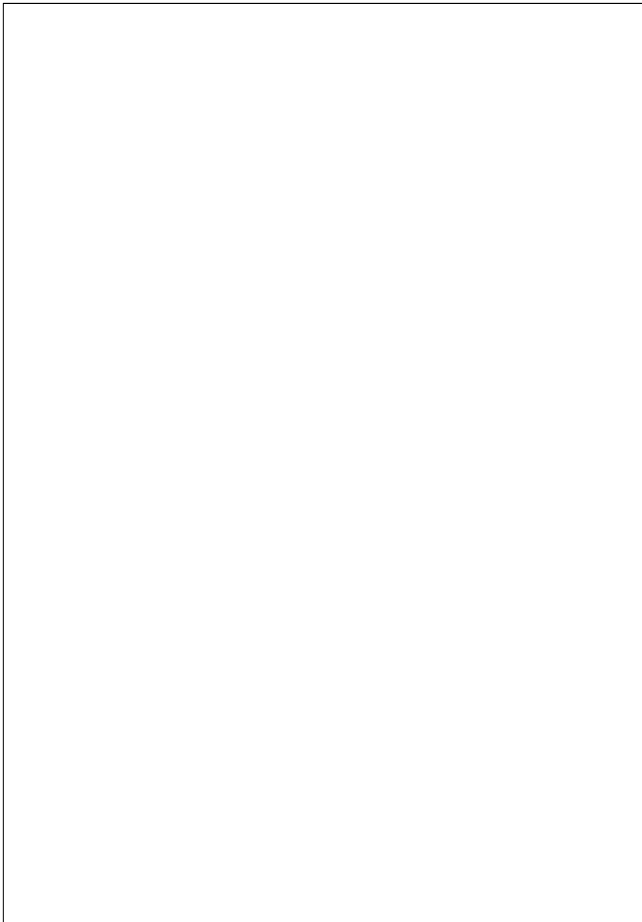
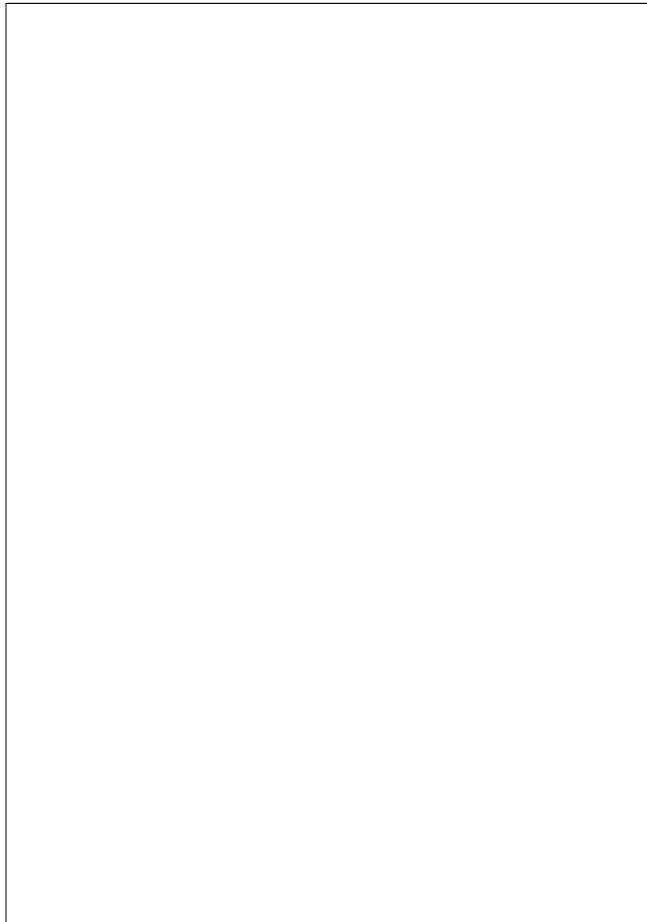
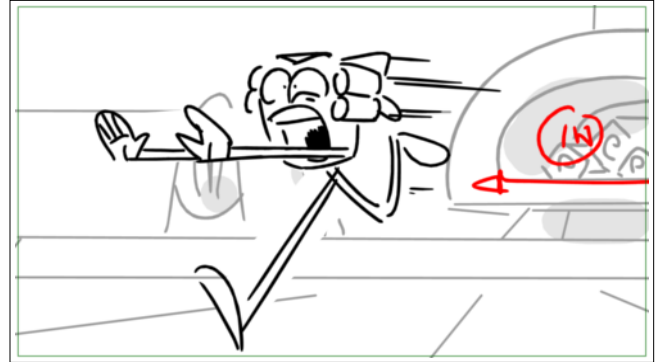
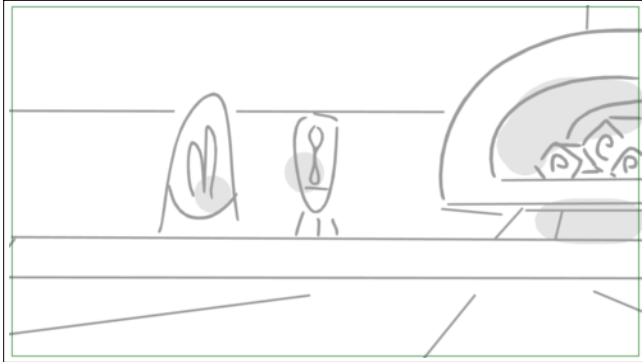



Scene	Duration	Panel	Duration
128	07:04	8	00:17

Scene	Duration	Panel	Duration
128	07:04	9	00:10

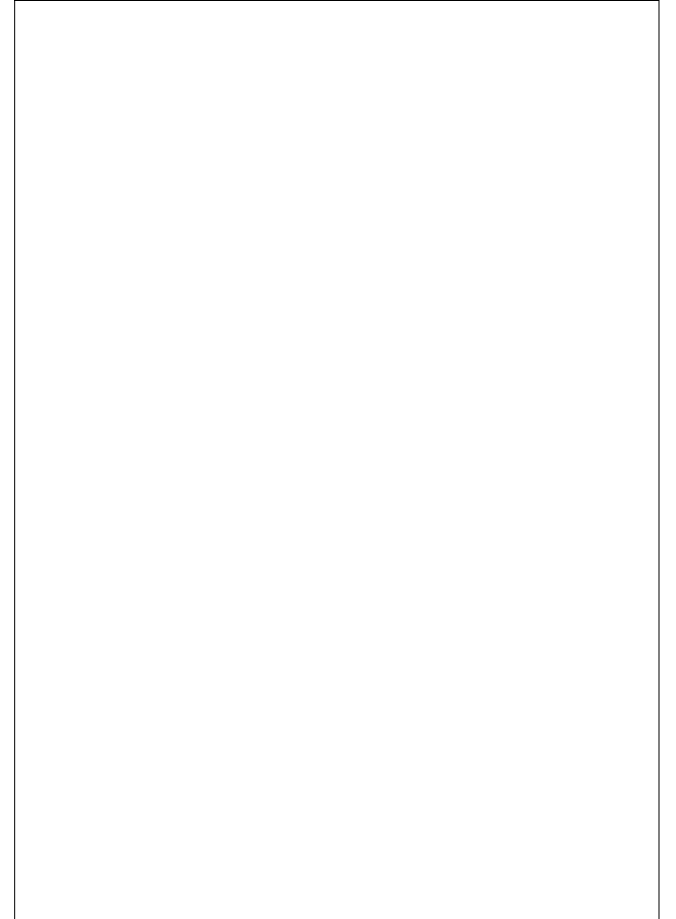
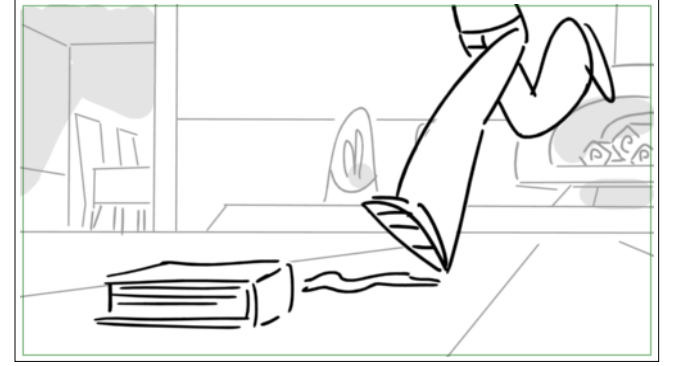
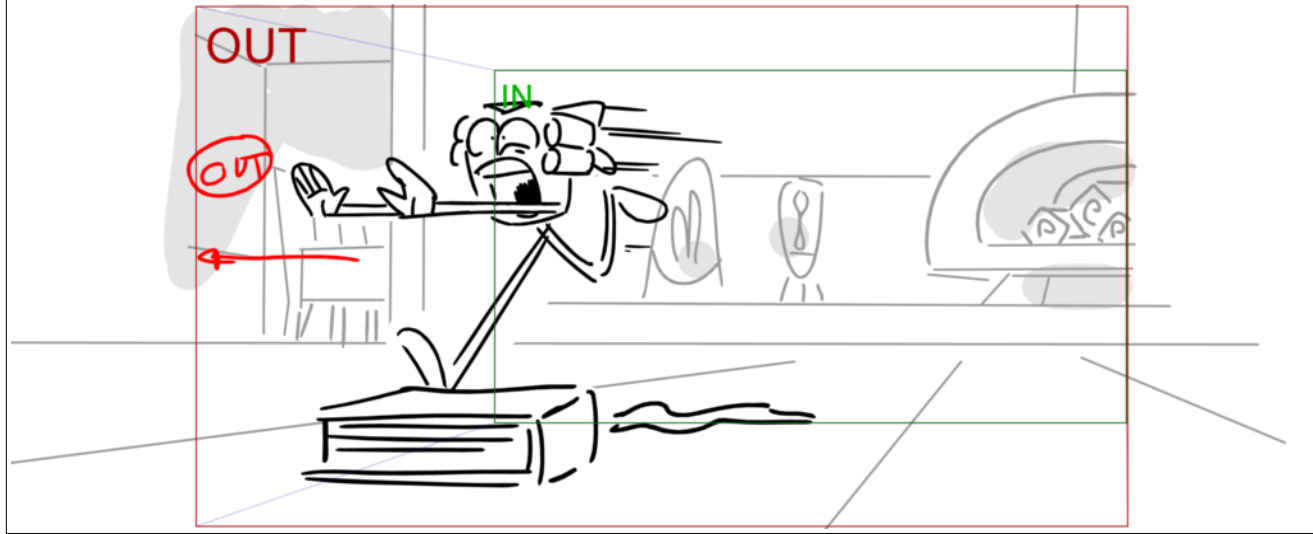



Scene	Duration	Panel	Duration
128	07:04	10	00:18

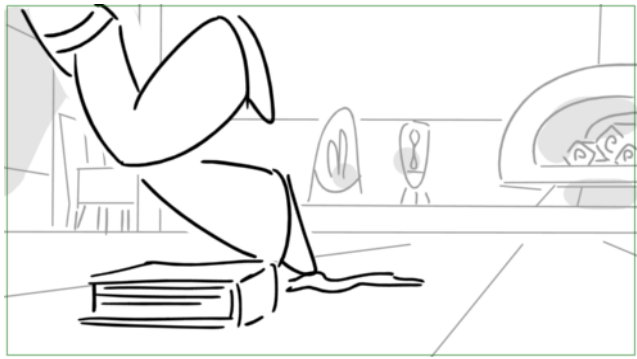

Scene	Duration	Panel	Duration
128	07:04	11	00:14

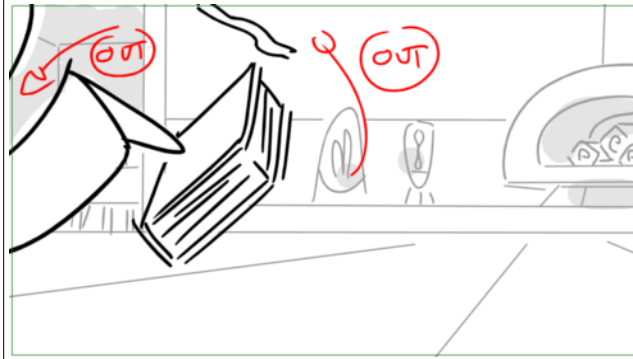

Scene	Duration	Panel	Duration
128	07:04	12	00:23

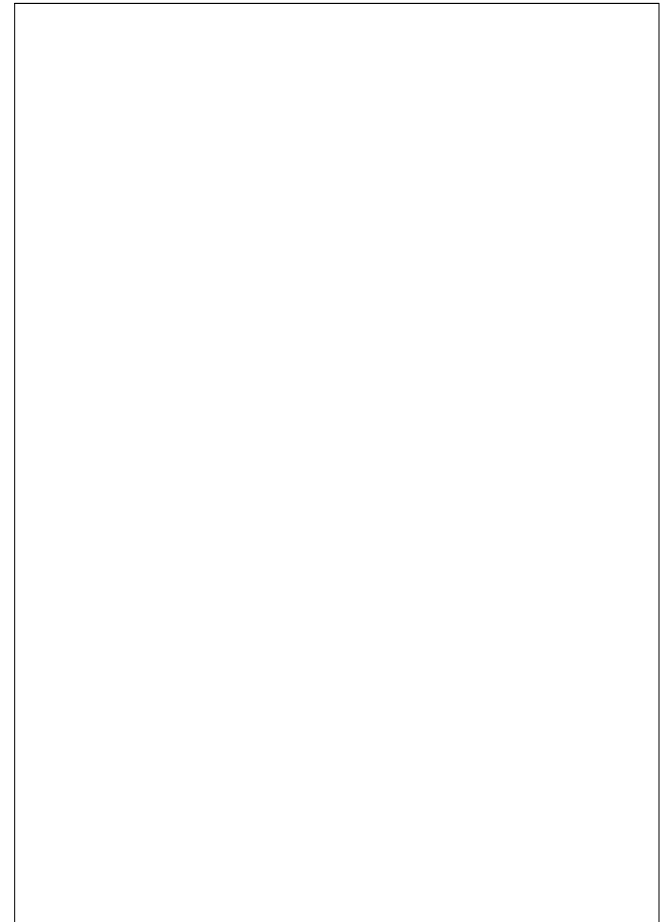
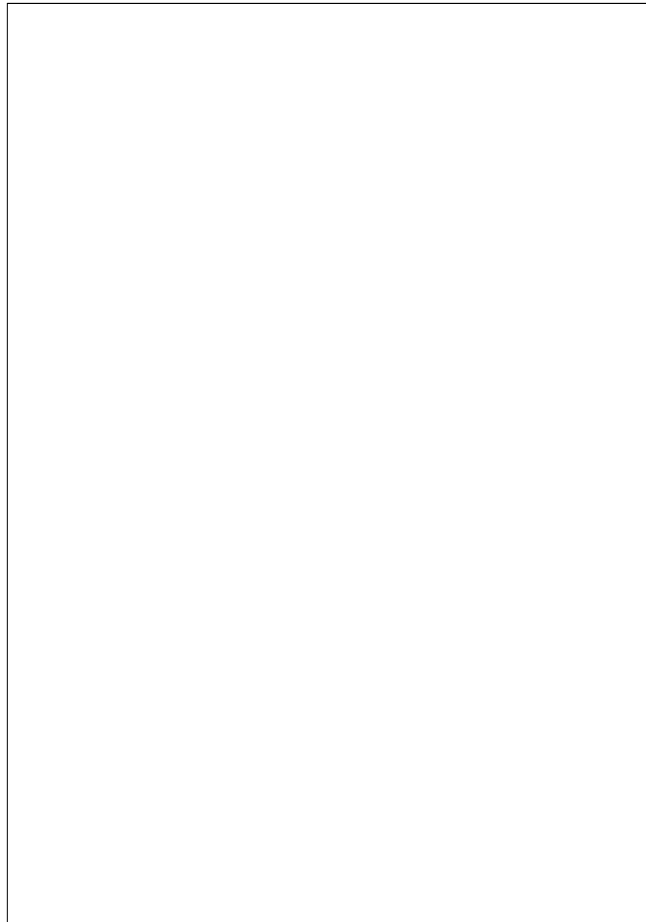
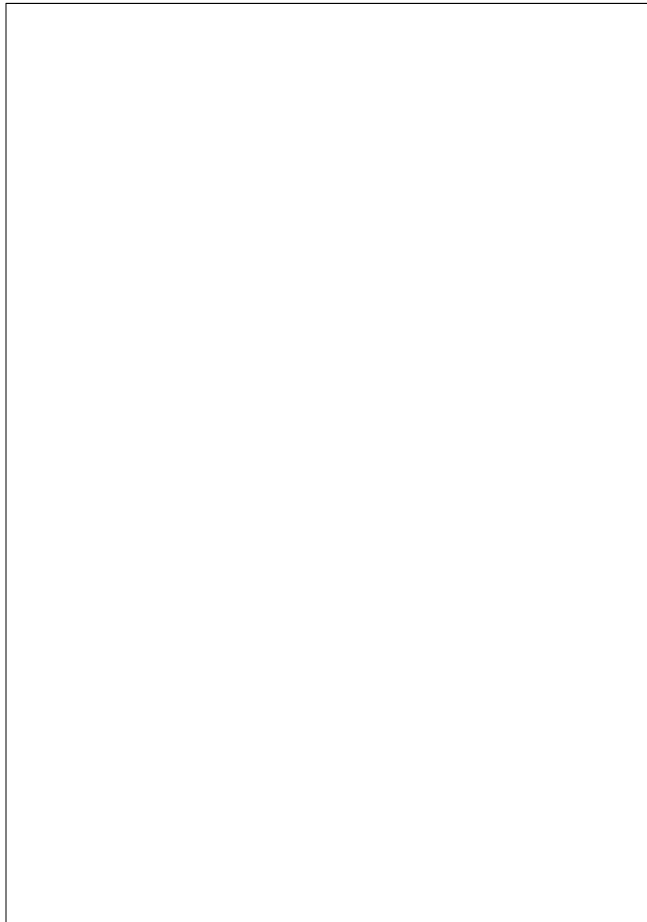
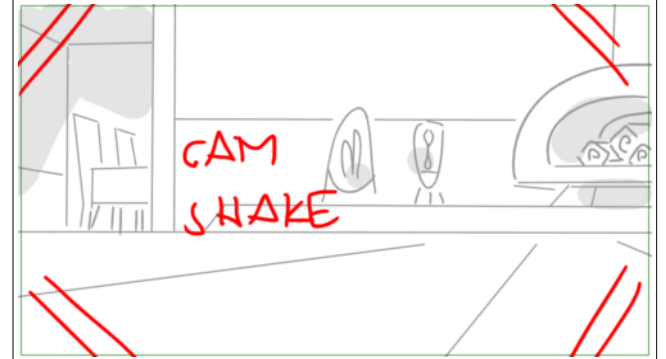



Scene	Duration	Panel	Duration
129	01:11	1	00:12



Scene	Duration	Panel	Duration
129	01:11	2	00:12



Scene	Duration	Panel	Duration
129	01:11	3	00:12





Scene	Duration	Panel	Duration
130	02:00	1	00:05

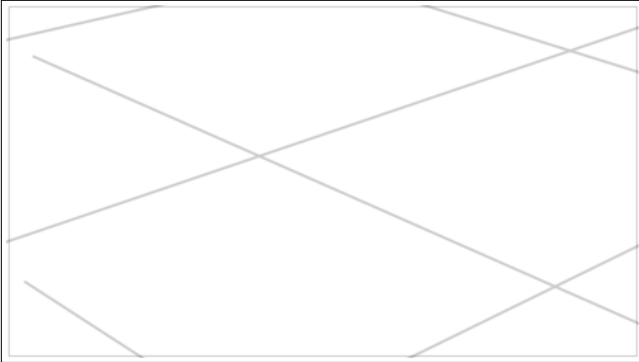

Dialogue
PU
Tiens tiens!

Scene	Duration	Panel	Duration
130	02:00	2	00:11

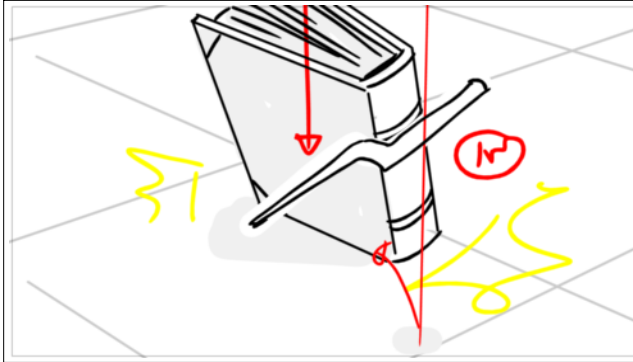

Dialogue
PU
Tiens tiens!

Scene	Duration	Panel	Duration
130	02:00	3	00:14

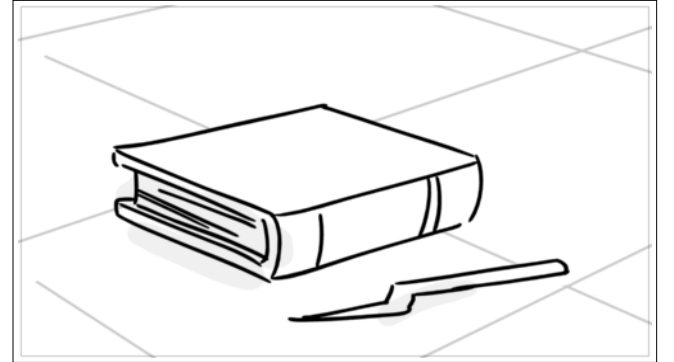

Dialogue
PU
Tiens tiens!

Scene	Duration	Panel	Duration
130	02:00	4	00:10

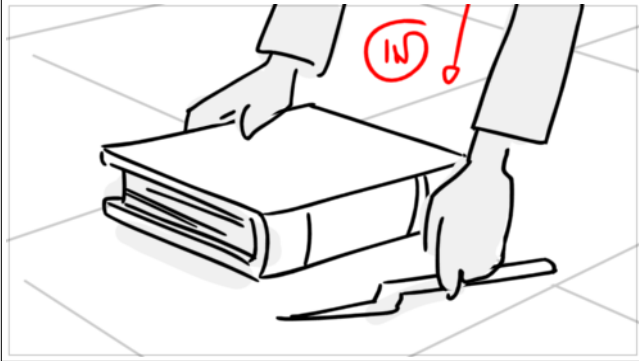

Scene	Duration	Panel	Duration
130	02:00	5	00:10

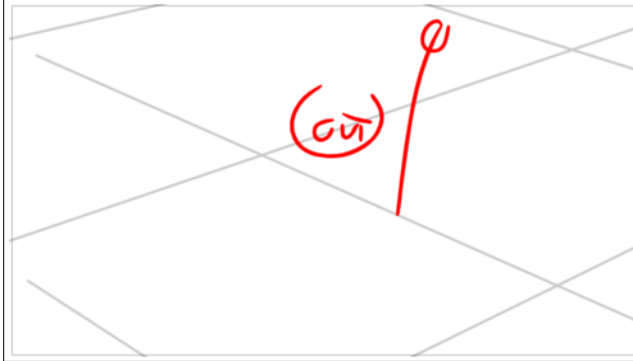

Scene	Duration	Panel	Duration
131	03:11	1	00:11



Scene	Duration	Panel	Duration
131	03:11	2	01:00



Dialogue

PU Cindy/voix de Monseigneur
Et si j'essayais moi-même de prononcer
la formule magique!

Scene	Duration	Panel	Duration
131	03:11	3	01:00



Dialogue

PU Cindy/voix de Monseigneur
Et si j'essayais moi-même de prononcer
la formule magique!

Scene	Duration	Panel	Duration
131	03:11	4	01:00



Dialogue

PU Cindy/voix de Monseigneur
Et si j'essayais moi-même de prononcer
la formule magique!

Scene	Duration	Panel	Duration
132	15:19	1	00:11



Scene	Duration	Panel	Duration
132	15:19	2	00:12



Scene	Duration	Panel	Duration
132	15:19	3	01:08

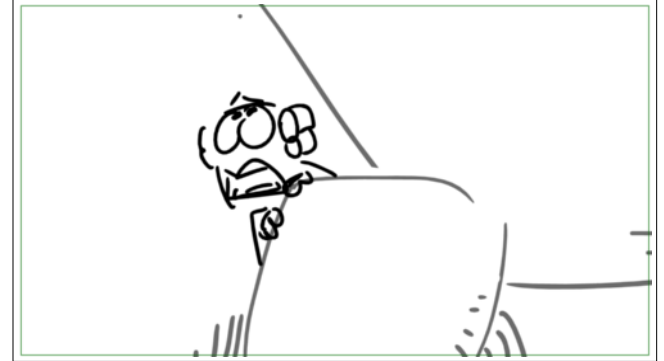

Dialogue

72. Monseigneur /voix de Cindy
Tu rêves chère amie !

Scene	Duration	Panel	Duration
132	15:19	4	02:00



Dialogue

72. Monseigneur /voix de Cindy
Ta mère elle-même, n'a pas réussi...

Scene	Duration	Panel	Duration
132	15:19	5	01:13

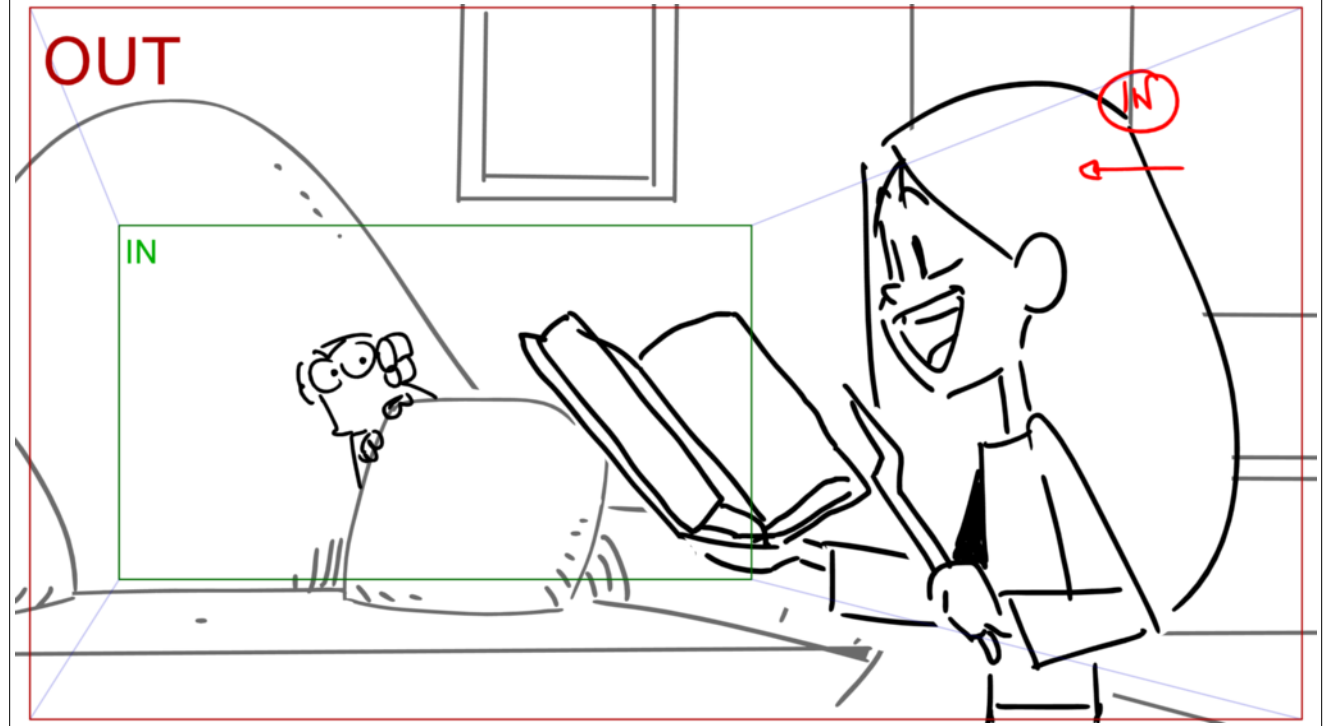

Dialogue

71. Cindy/voix de Monseigneur
Ah la voilà !

Scene	Duration	Panel	Duration
132	15:19	6	02:12



Dialogue

71. Cindy/voix de Monseigneur
(elle se racle la voix) Motus et bouche
décousue...

Scene	Duration	Panel	Duration
132	15:19	7	03:06



Dialogue

73. Cindy/voix de Monseigneur
... Que nos voix se rééchangent !

Scene	Duration	Panel	Duration
132	15:19	8	01:00



Scene	Duration	Panel	Duration
132	15:19	9	01:15



Dialogue

PU Monseigneur /voix de Cindy
Tu vois! Je te l'avais bien dit!

Scene	Duration	Panel	Duration
132	15:19	10	01:00



Dialogue

74. FEROCIA /voix de WILLOW
C'est pas un peu fini ce bazar ?!!

Scene	Duration	Panel	Duration
132	15:19	11	00:17

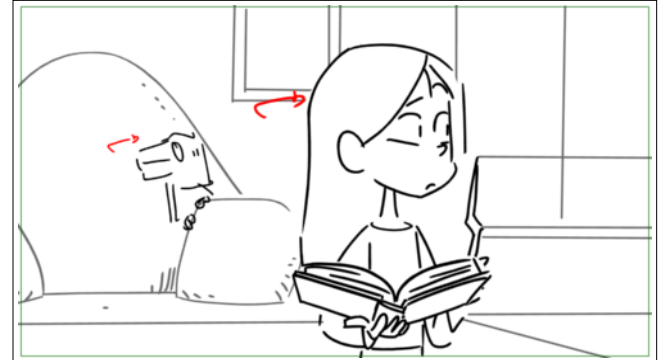

Dialogue

74. FEROCIA /voix de WILLOW
C'est pas un peu fini ce bazar ?!!

Scene	Duration	Panel	Duration
133	03:16	1	00:15



Scene	Duration	Panel	Duration
133	03:16	2	01:17



Scene	Duration	Panel	Duration
133	03:16	3	00:16

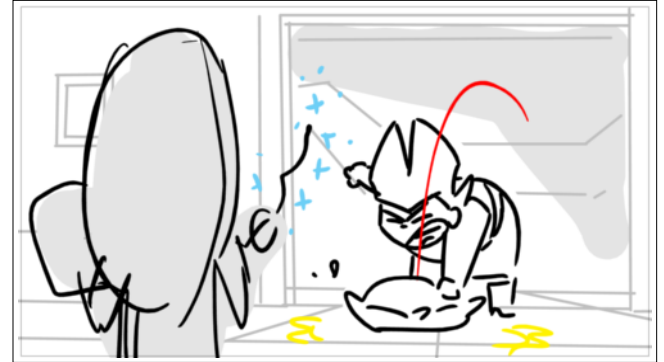

Scene	Duration	Panel	Duration
133	03:16	4	00:18

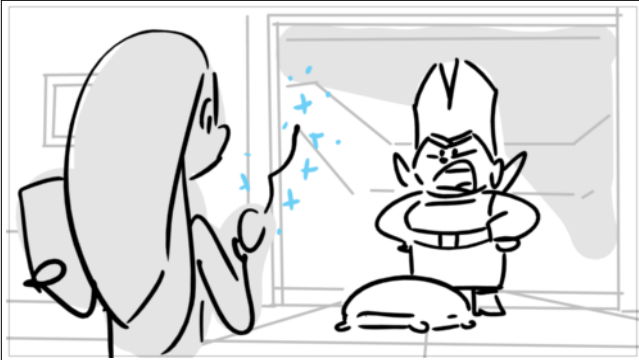

Action Notes

FX autour de la baguette

Scene	Duration	Panel	Duration
134	04:08	1	00:20

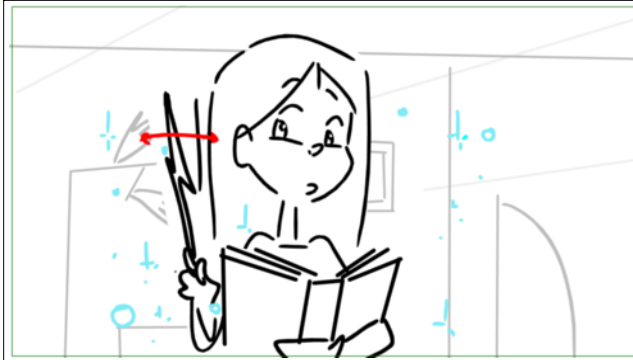

Action Notes

La baguette frétille

Scene	Duration	Panel	Duration
134	04:08	2	00:16

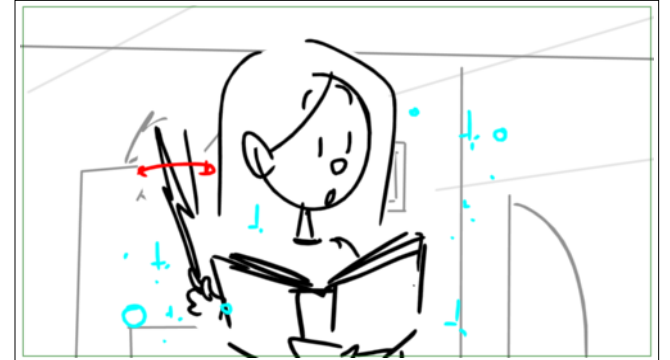

Action Notes

Aussitôt les pages du grimoire frétille. Effet magique.

Scene	Duration	Panel	Duration
134	04:08	3	00:14



Action Notes

Aussitôt les pages du grimoire frétille. Effet magique.

Scene	Duration	Panel	Duration
134	04:08	4	02:08

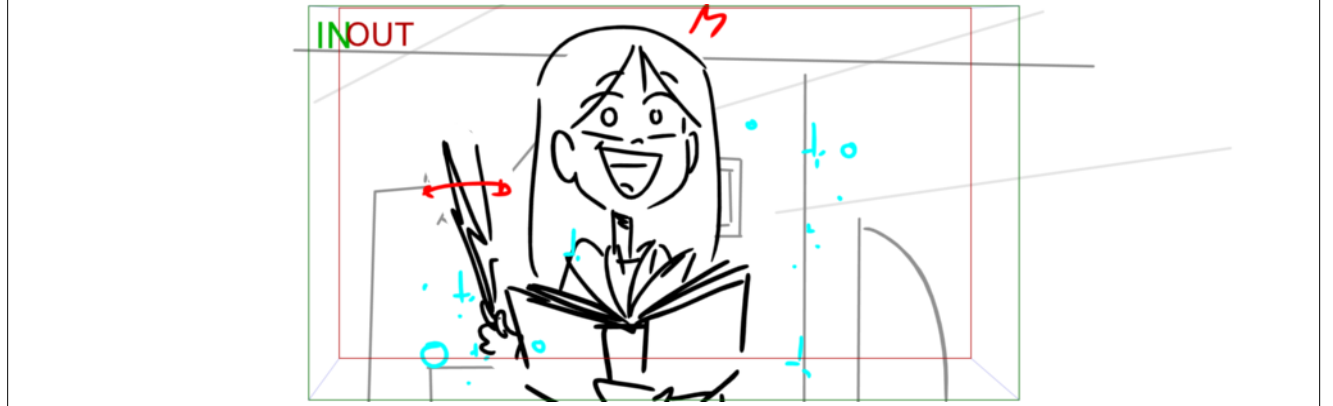

Dialogue

75. Cindy/voix de Monseigneur
 (à elle-même) Mais bien sûr, on aurait dû y penser !

Scene	Duration	Panel	Duration
135	05:17	1	00:07



Scene	Duration	Panel	Duration
135	05:17	2	00:09



Scene	Duration	Panel	Duration
135	05:17	3	01:11

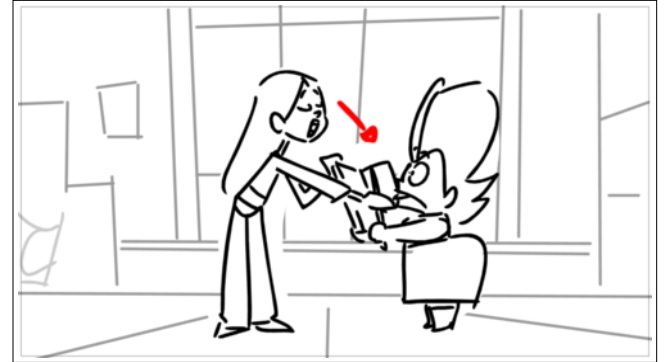

Dialogue

75. Cindy/voix de Monseigneur
Euh Tata,

Scene	Duration	Panel	Duration
135	05:17	4	03:15



Dialogue

75. Cindy/voix de Monseigneur
la formule pour changer de voix,
c'était quoi déjà ?

Scene	Duration	Panel	Duration
136	07:22	1	00:10



Scene	Duration	Panel	Duration
136	07:22	2	00:20



Scene	Duration	Panel	Duration
136	07:22	3	00:22



Scene	Duration	Panel	Duration
136	07:22	4	03:23



Dialogue

76. FEROCIA /voix de WILLOW

« Motus et bouche décousue, que nos voix se rééchantent », pourquoi ?



Scene	Duration	Panel	Duration
136	07:22	5	00:11

NO PANEL

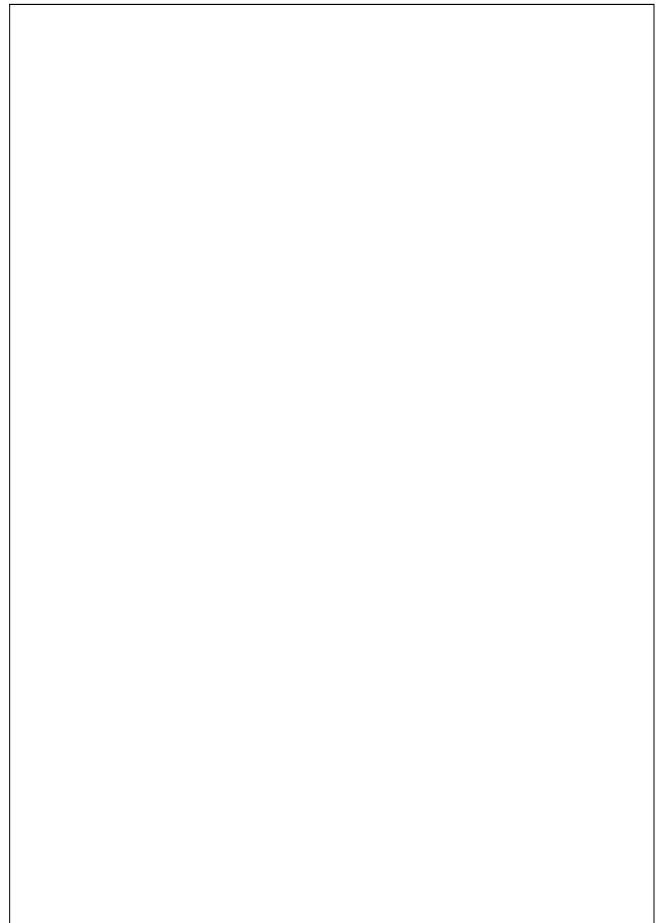
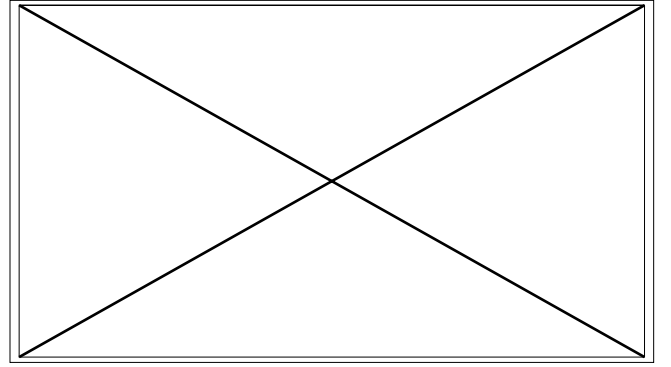
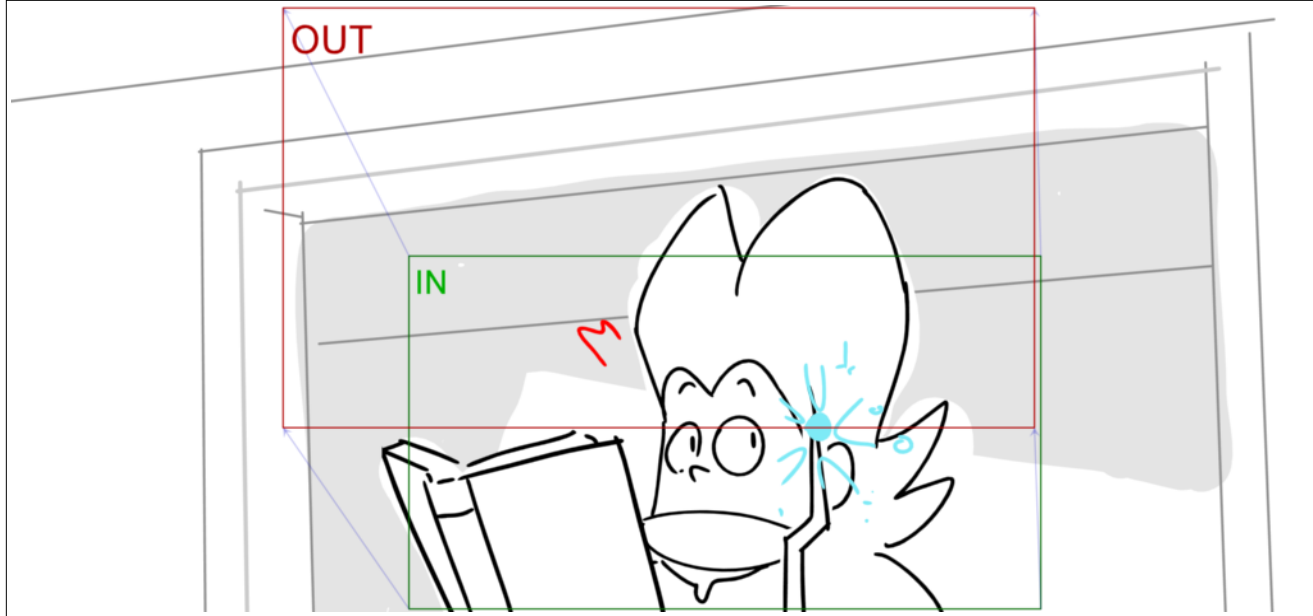



Scene	Duration	Panel	Duration
136	07:22	6	00:11

NO PANEL

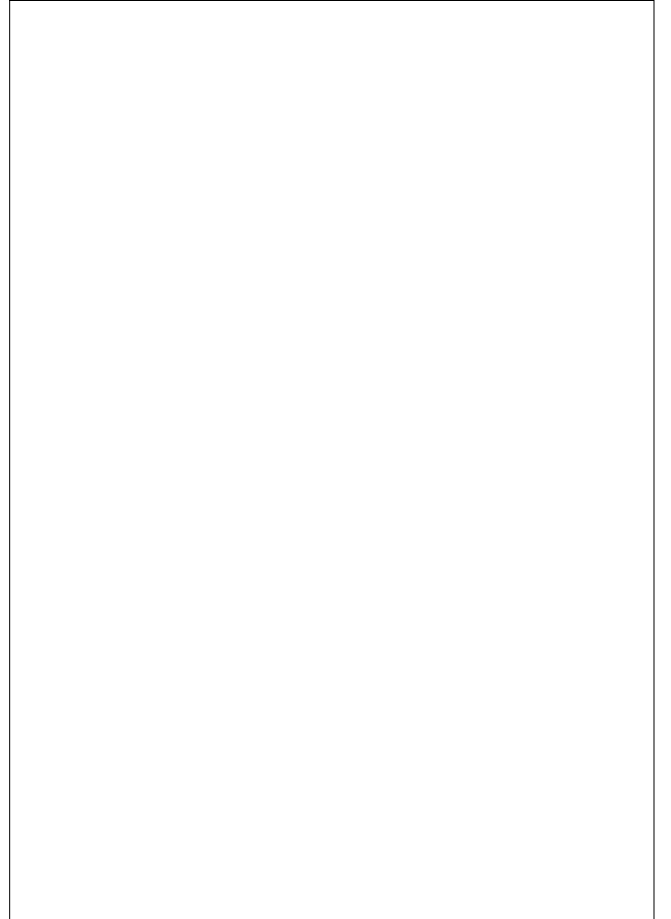
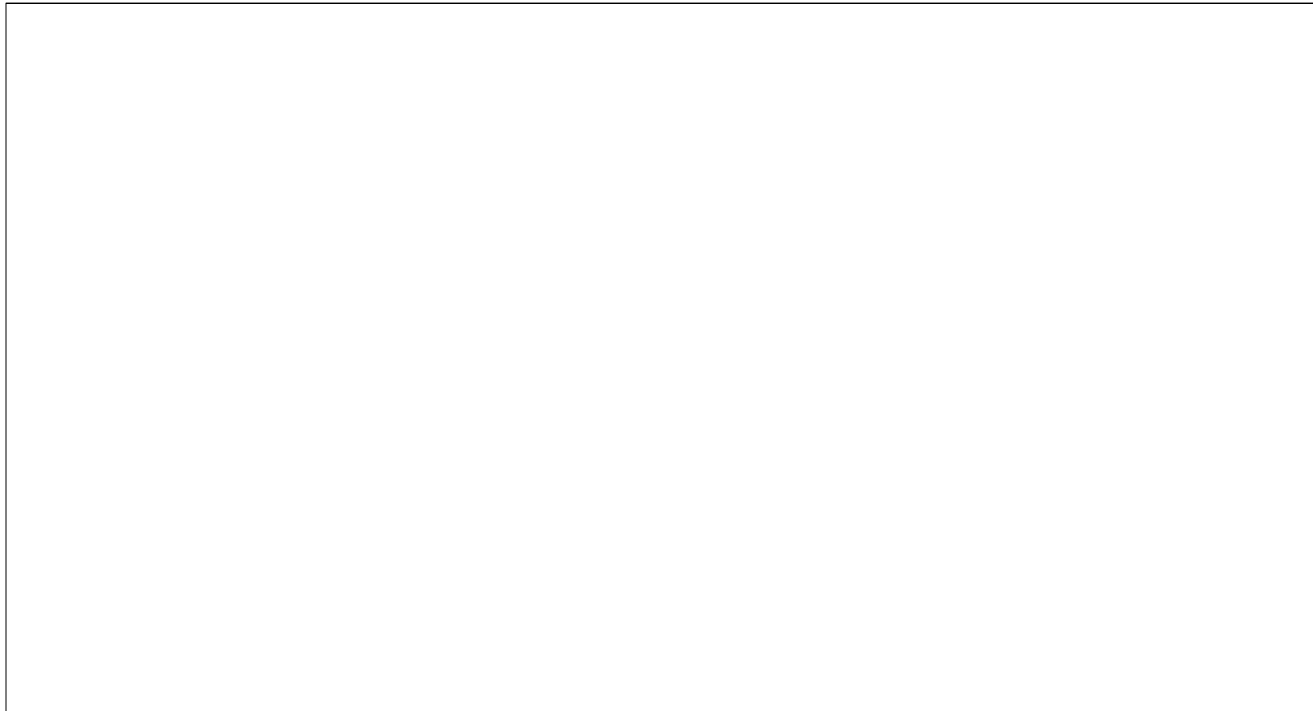
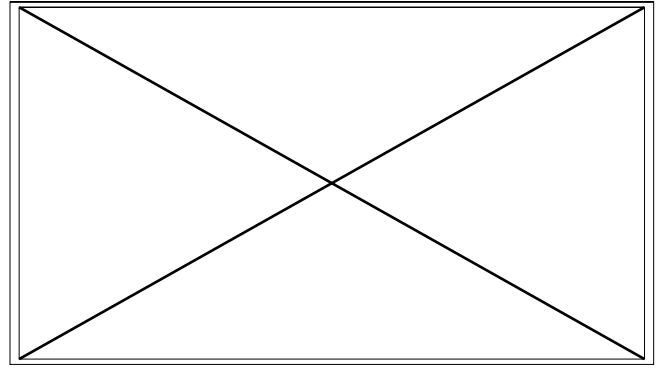
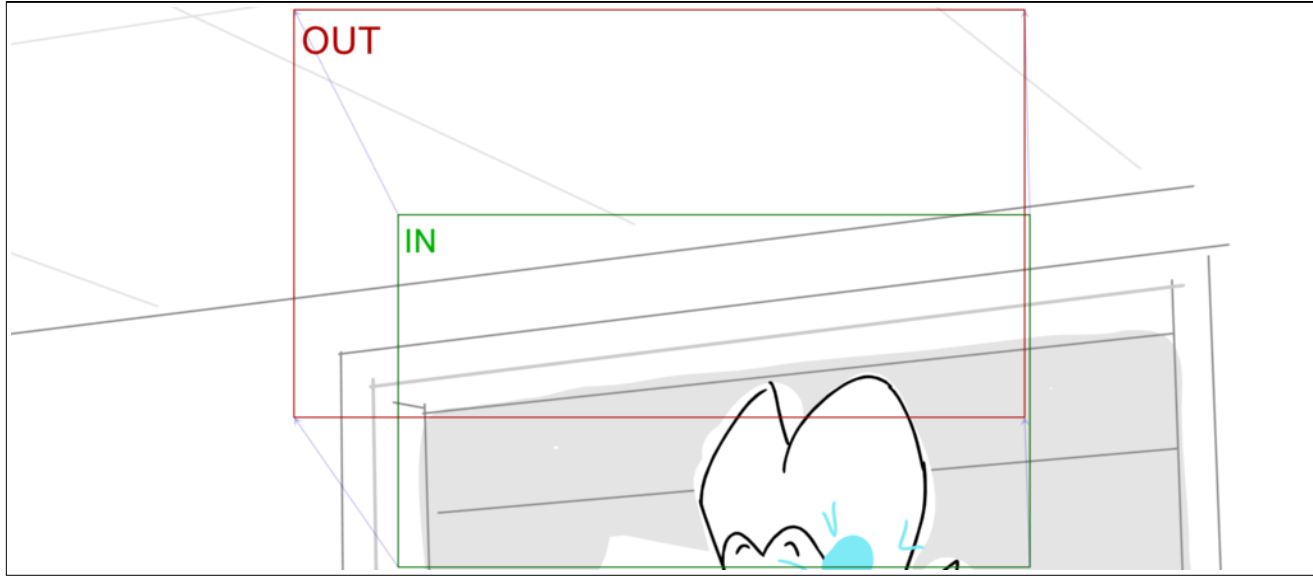



Scene	Duration	Panel	Duration
136	07:22	7	01:00

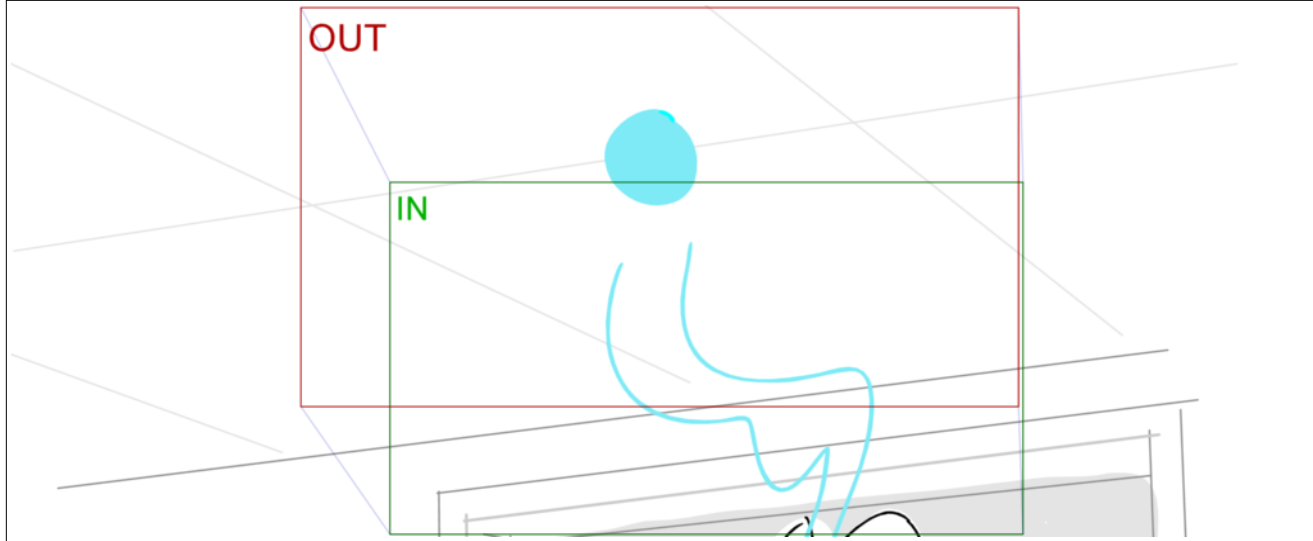

Action Notes

Le fx magique se déploie dans l'air

Scene	Duration	Panel	Duration
137	02:03	1	00:10

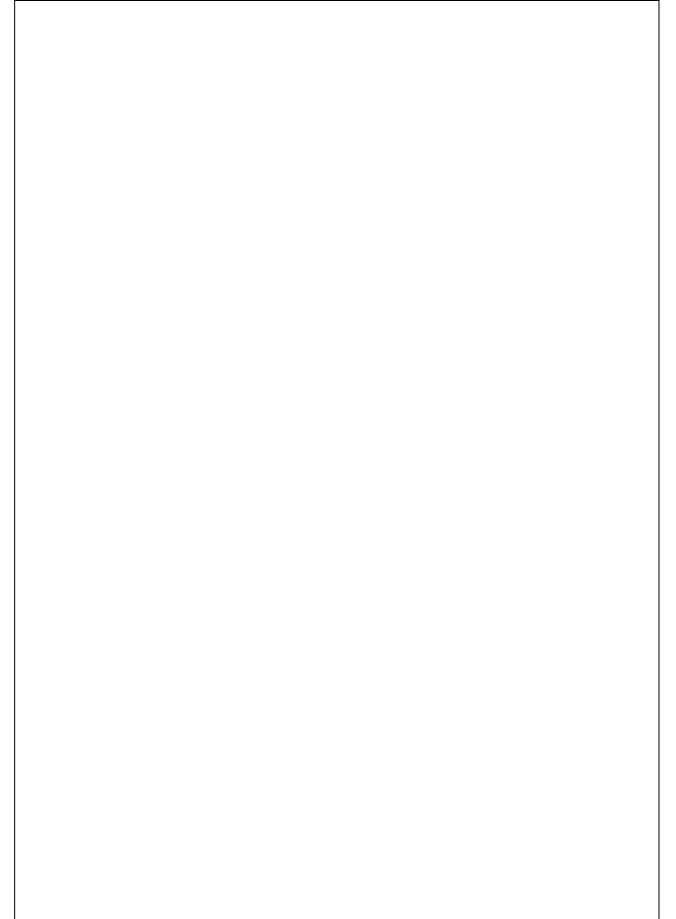

Scene	Duration	Panel	Duration
137	02:03	2	00:15



Dialogue
77.FEROCIA
HIC !

Action Notes

passe dans chacun occasionant le hoquet

Scene	Duration	Panel	Duration
137	02:03	3	00:14

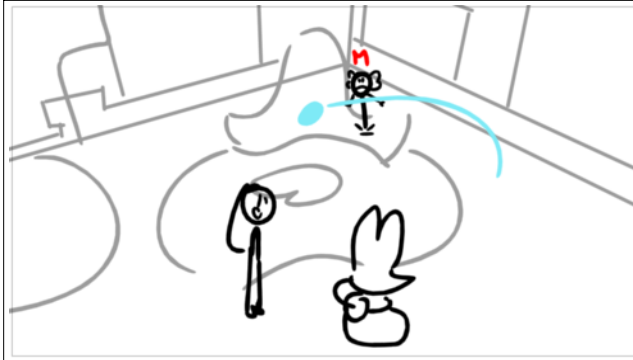

Dialogue
77. MONSEIGNEUR
HIC !

Scene	Duration	Panel	Duration
137	02:03	4	00:14



Dialogue
77. CINDY,
HIC !



Scene	Duration	Panel	Duration
138	01:12	1	00:09



Scene	Duration	Panel	Duration
138	01:12	2	00:10

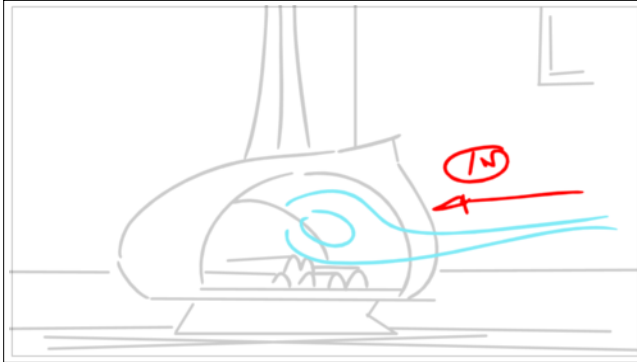

Scene	Duration	Panel	Duration
138	01:12	3	00:09

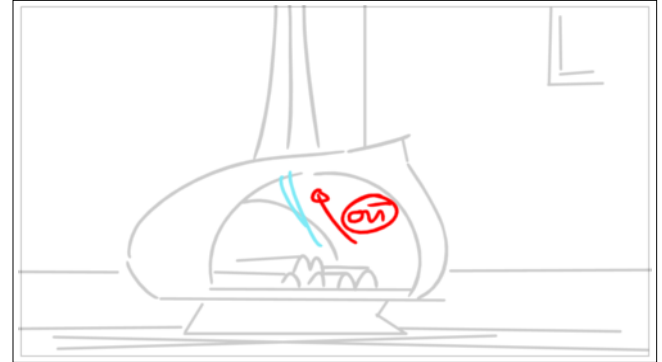

Action Notes

Le sort magique disparaît par la cheminée



Scene	Duration	Panel	Duration
138	01:12	4	00:09



Scene	Duration	Panel	Duration
139	01:19	1	00:10



Scene	Duration	Panel	Duration
139	01:19	2	00:10

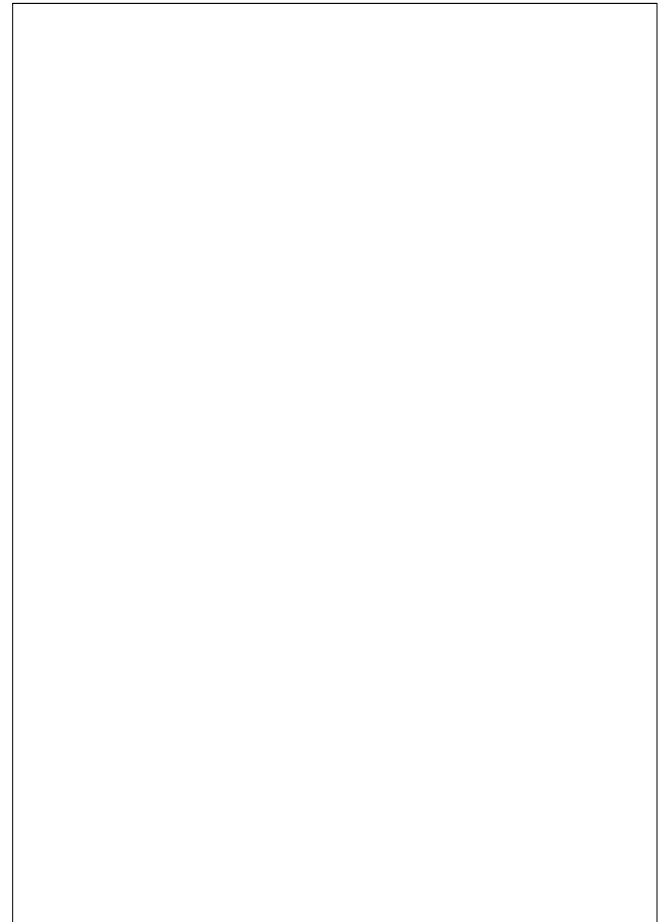
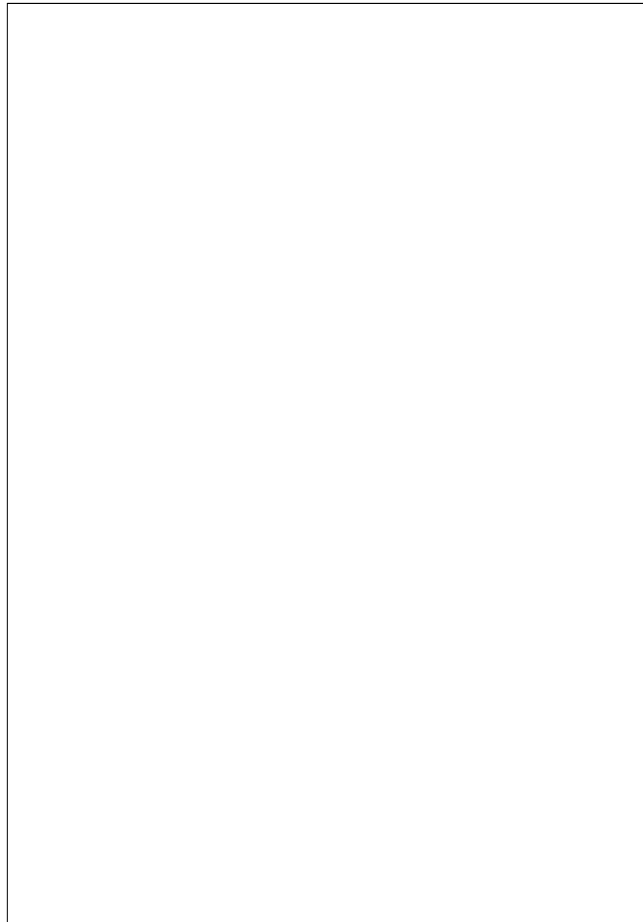
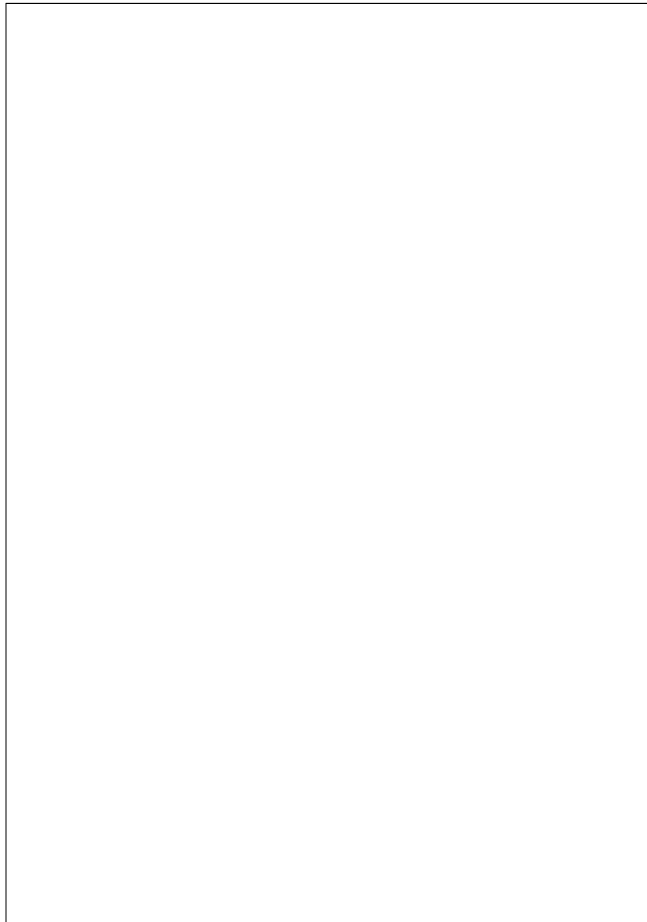
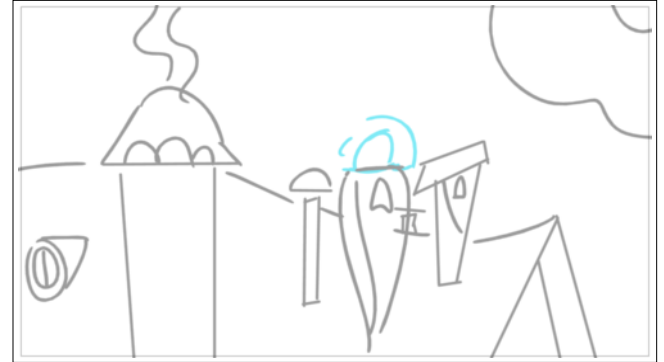

Scene	Duration	Panel	Duration
139	01:19	3	00:10



Scene	Duration	Panel	Duration
139	01:19	4	00:14



Scene	Duration	Panel	Duration
140	03:23	1	01:00

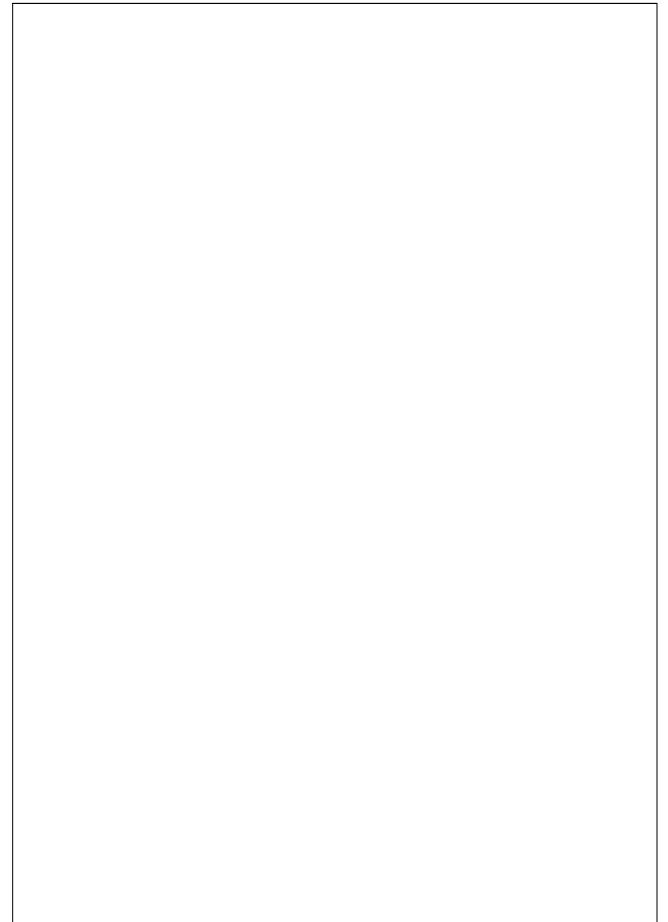
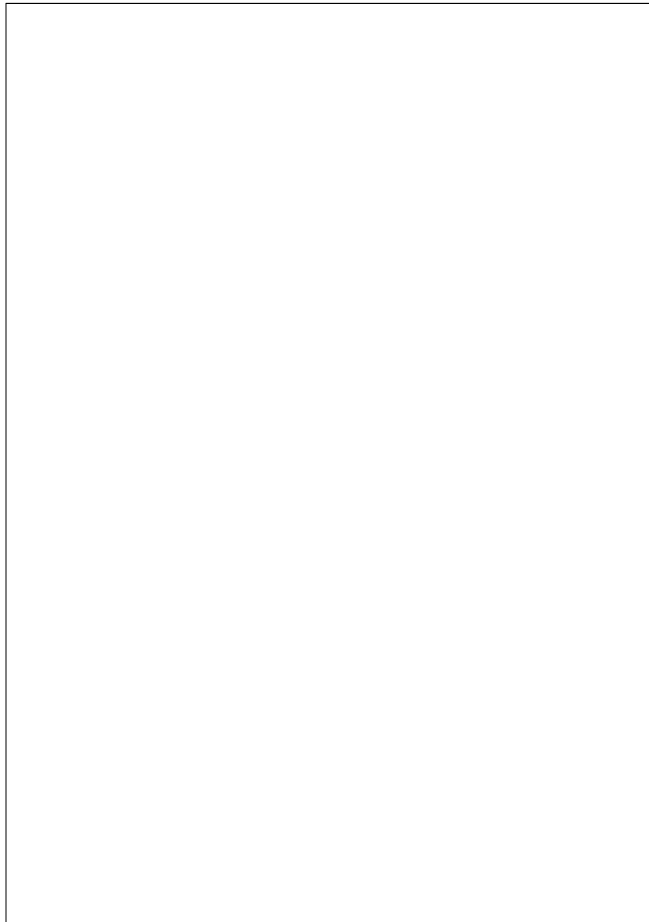

Scene	Duration	Panel	Duration
140	03:23	2	00:18



Dialogue
78. CINDY
Ça marche !!

Scene	Duration	Panel	Duration
140	03:23	3	02:05



Dialogue
78. CINDY
Le grimoire ne répond qu'à la voix de
maman,

Scene	Duration	Panel	Duration
141	15:12	1	02:09



Dialogue
78. CINDY
c'est pour ça qu'elle n'y arrivait pas...

Scene	Duration	Panel	Duration
141	15:12	2	00:06

Scene	Duration	Panel	Duration
141	15:12	3	00:07

Scene	Duration	Panel	Duration
141	15:12	4	00:07



Dialogue
 78. CINDY
 Ahmed, j'arriiiiiiiiiiiiive !

Dialogue
 78. CINDY
 Ahmed, j'arriiiiiiiiiiiiive !

Dialogue
 78. CINDY
 Ahmed, j'arriiiiiiiiiiiiive !

Scene	Duration	Panel	Duration
141	15:12	5	00:07

Scene	Duration	Panel	Duration
141	15:12	6	00:07

Scene	Duration	Panel	Duration
141	15:12	7	00:07



Dialogue
 78. CINDY
 Ahmed, j'arriiiiiiiiiive !

Dialogue
 78. CINDY
 Ahmed, j'arriiiiiiiiiive !

Dialogue
 78. CINDY
 Ahmed, j'arriiiiiiiiiive !

Scene	Duration	Panel	Duration
141	15:12	8	00:07



Dialogue
 78. CINDY
 Ahmed, j'arriiiiiiiiiive !

Scene	Duration	Panel	Duration
141	15:12	9	00:07



Dialogue
 78. CINDY
 Ahmed, j'arriiiiiiiiiive !

Scene	Duration	Panel	Duration
141	15:12	10	00:07

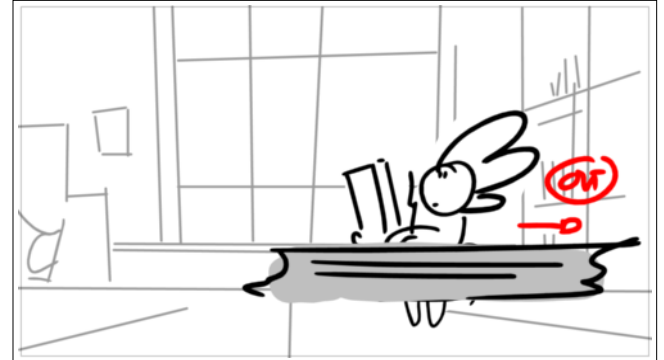

Scene	Duration	Panel	Duration
141	15:12	11	00:23

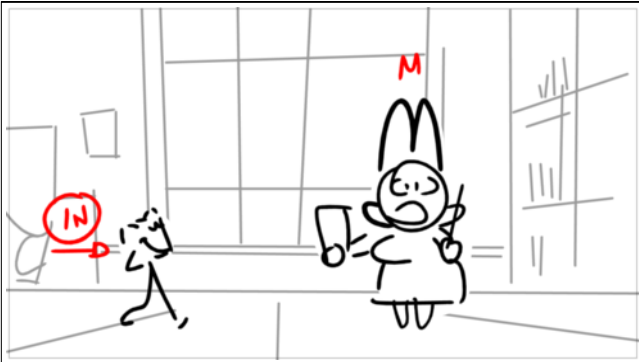

Dialogue

79. Férocía (réalisant)
Mais alors,

Scene	Duration	Panel	Duration
141	15:12	12	04:01



Dialogue

79. Férocía (réalisant)
ça veut dire que j'aurais pu utiliser
le grimoire magique pour moi !?!

Scene	Duration	Panel	Duration
141	15:12	13	03:04



Dialogue

PU MONSEIGNEUR
En effet, ça m'a tout l'air d'une
occasion manquée!

Scene	Duration	Panel	Duration
141	15:12	14	02:13

Scene	Duration	Panel	Duration
142	01:12	1	00:10

Scene	Duration	Panel	Duration
142	01:12	2	00:05



Dialogue
 79. Férocía (réalisant)
 NOOOOON !



Scene	Duration	Panel	Duration
142	01:12	3	00:07

Scene	Duration	Panel	Duration
142	01:12	4	00:15

NO PANEL

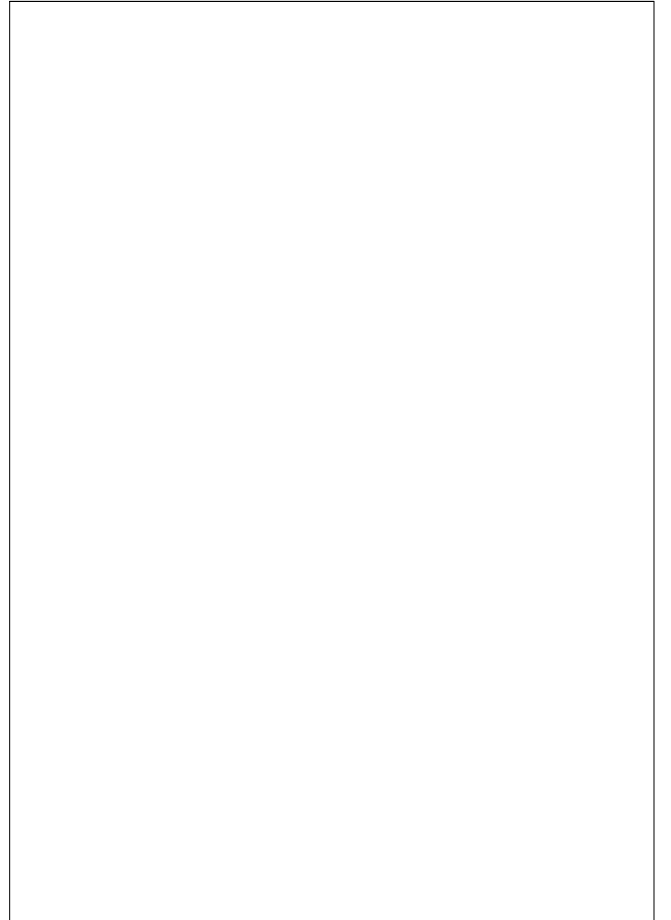
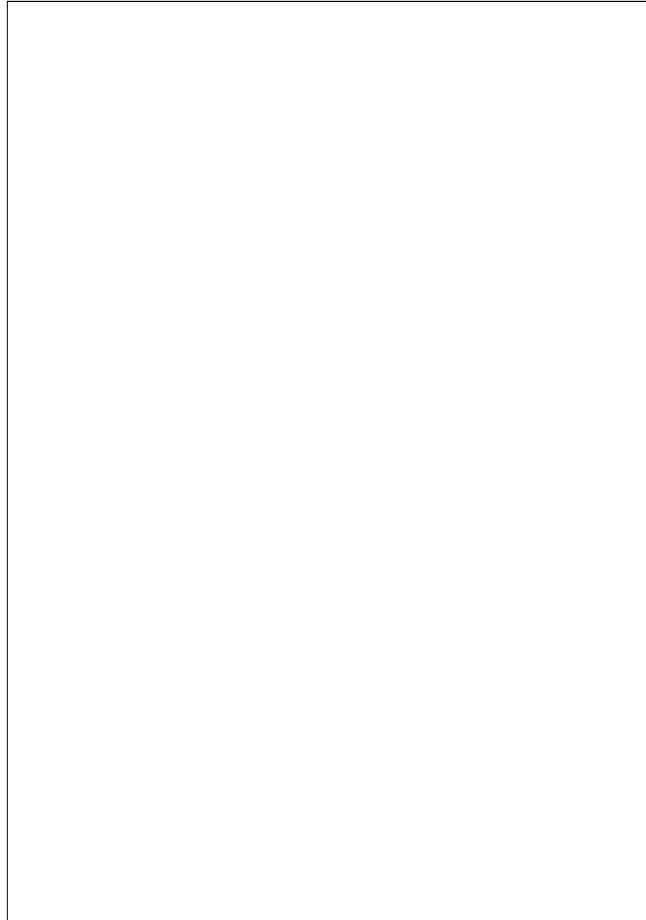
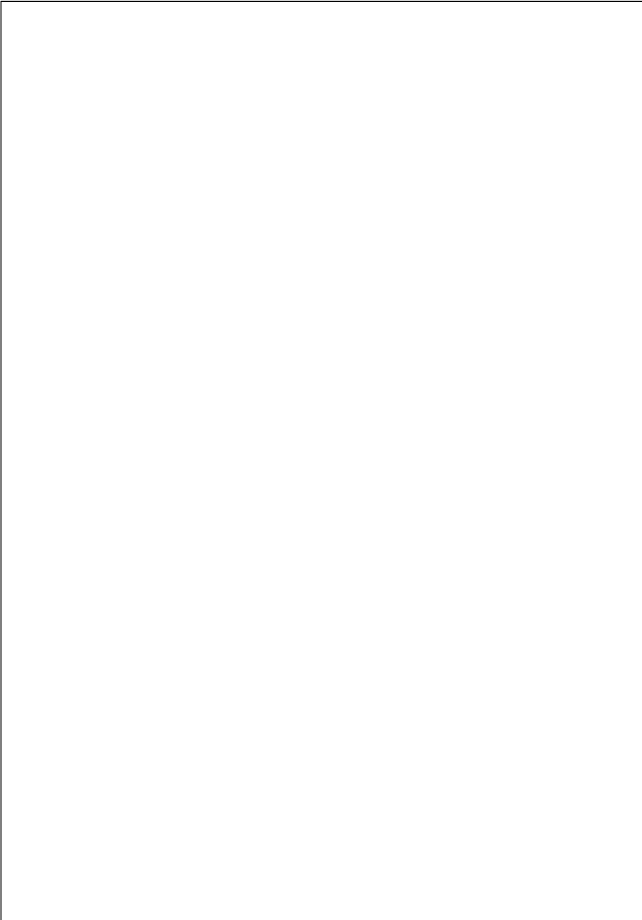
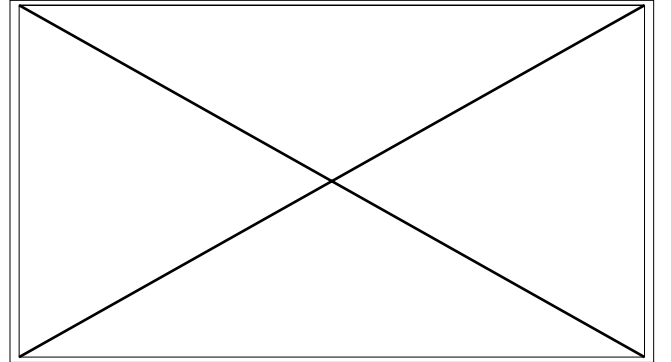
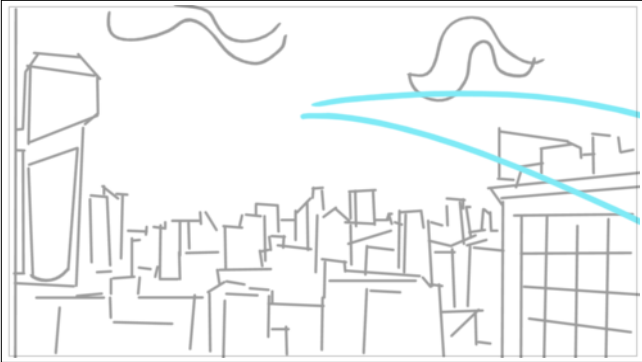



Scene	Duration	Panel	Duration
143	03:10	1	00:22

NO PANEL

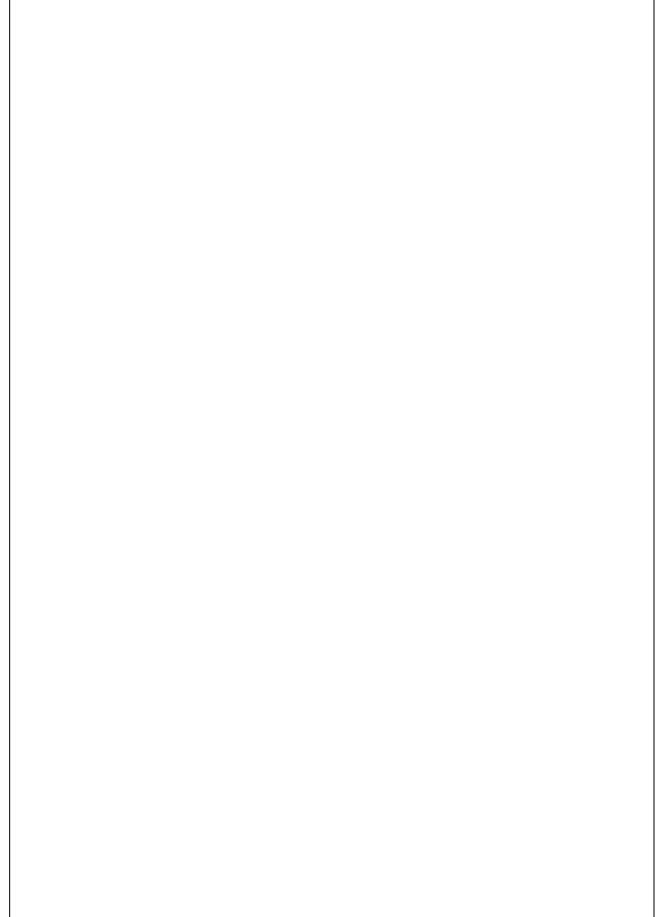
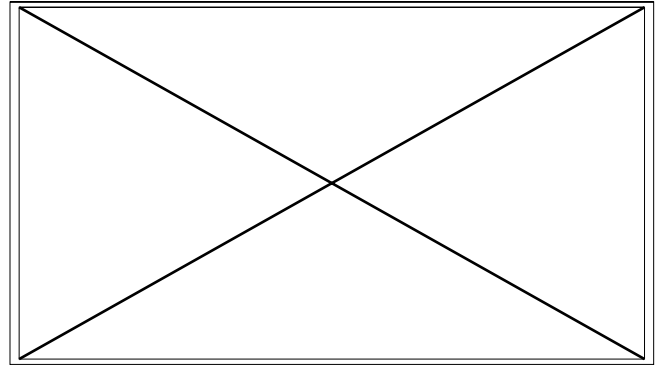
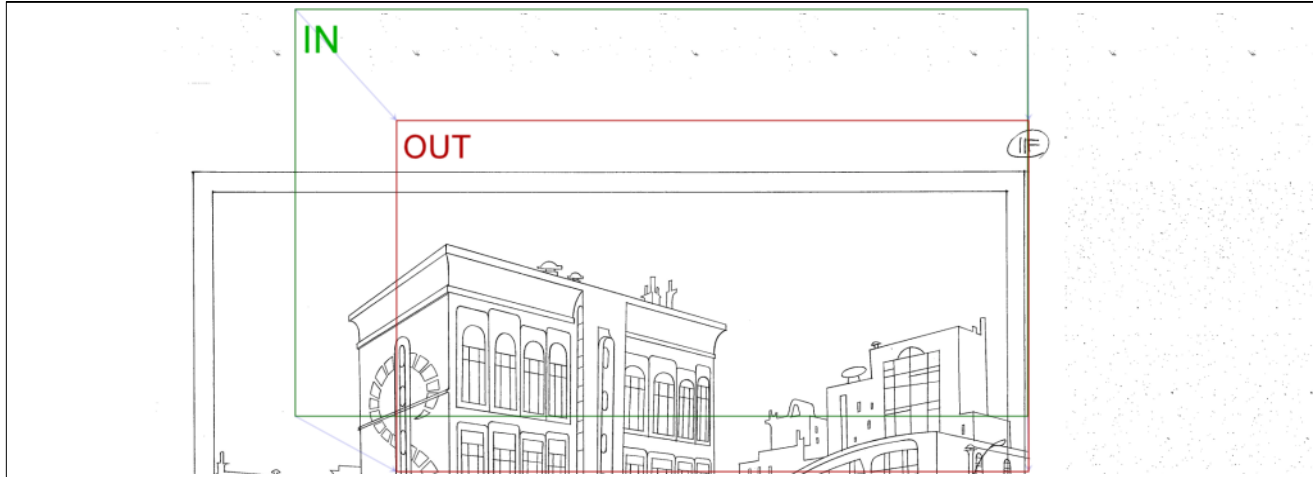



Scene	Duration	Panel	Duration
143	03:10	2	00:05

NO PANEL

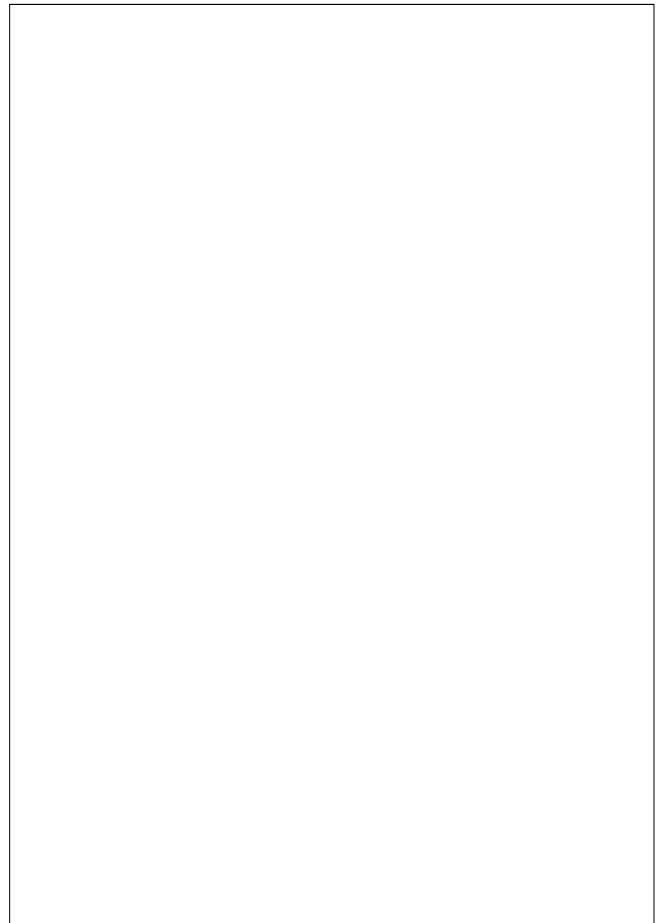
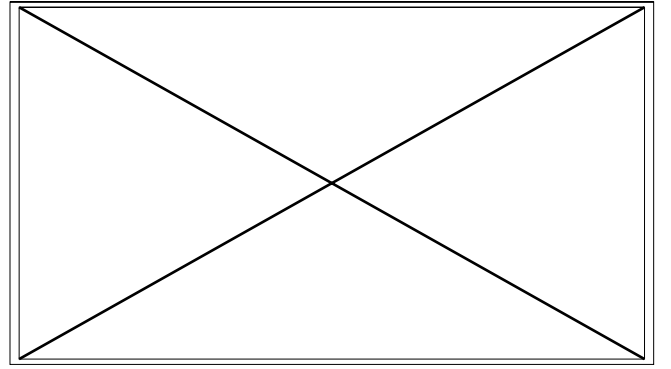
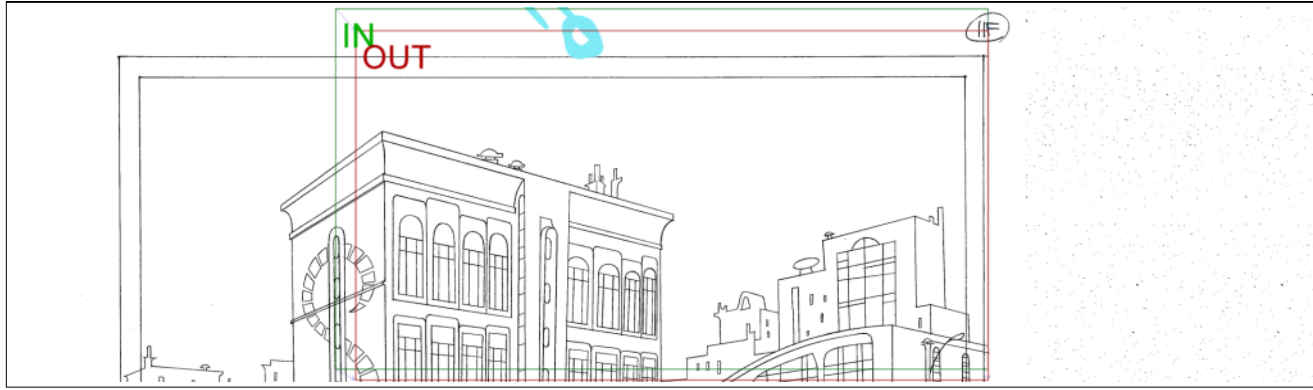



Scene	Duration	Panel	Duration
143	03:10	3	02:08

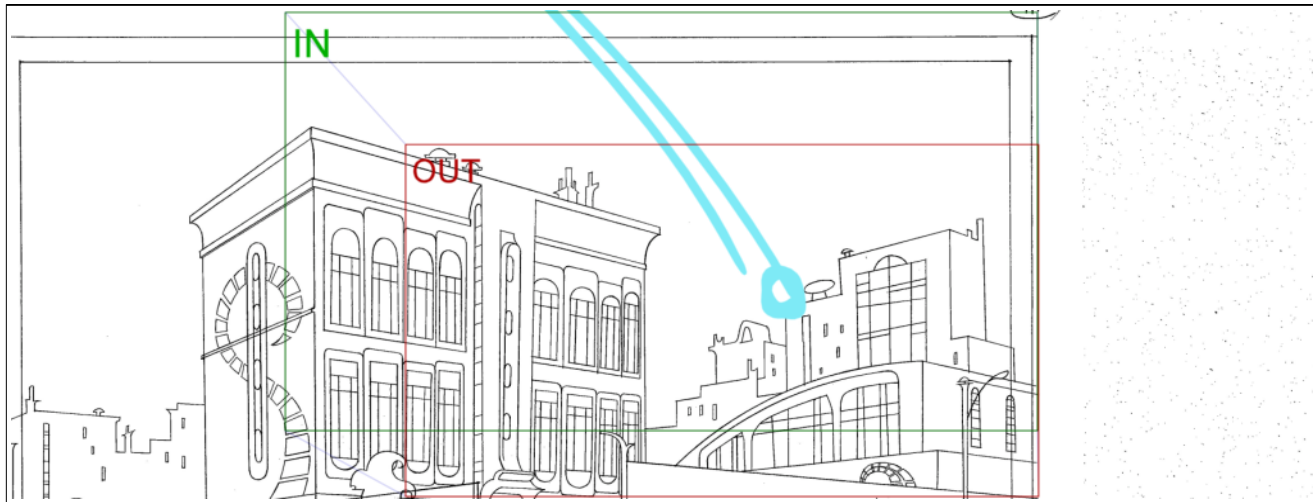

Dialogue
36. JOJO
A maîtriser la force apprendre tu dois...

Scene	Duration	Panel	Duration
144	03:00	1	01:00

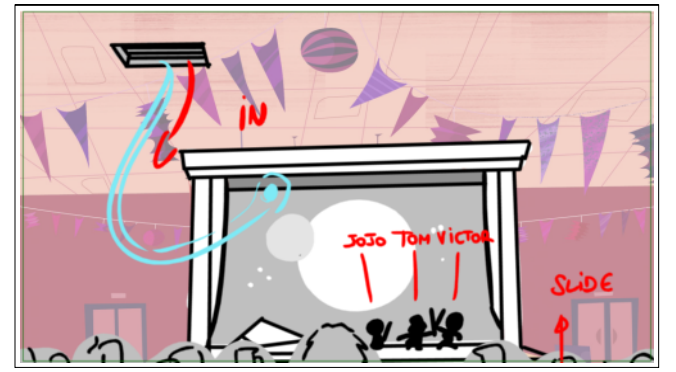

Action Notes
Le fx magique entre par le plafond

Scene	Duration	Panel	Duration
144	03:00	2	01:00

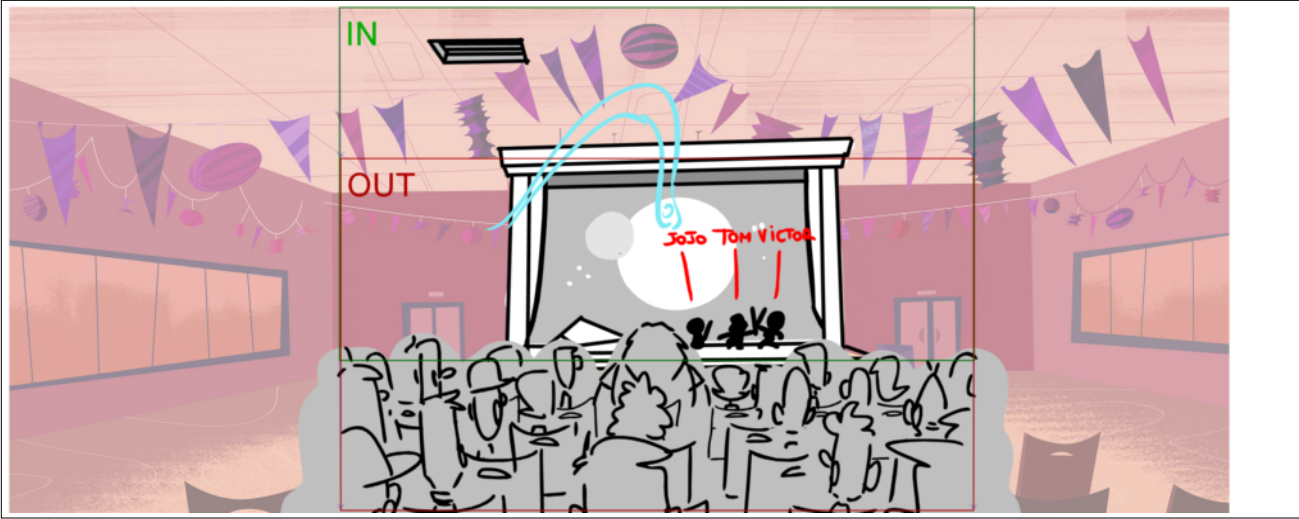

Action Notes

Et se dirige vers Gregor

Scene	Duration	Panel	Duration
144	03:00	3	01:00



Action Notes

Sur scene, Tom se bat avec Victor

Scene	Duration	Panel	Duration
145	02:12	1	00:17



Dialogue

37. Tom/VOIX de grégor (le coupe, à fond en colère)
 Silence Maître Yoga, voici la réponse de mon sabre laser !

Scene	Duration	Panel	Duration
145	02:12	2	00:12



Dialogue

80. GREGOR
 Hic !

Scene	Duration	Panel	Duration
145	02:12	3	00:11



Dialogue

80. WILLOW
 Hic !

Scene	Duration	Panel	Duration
145	02:12	4	00:10



Scene	Duration	Panel	Duration
145	02:12	5	00:12



Scene	Duration	Panel	Duration
146	04:09	1	01:00



Action Notes

Sur scène victor est à terre



Scene	Duration	Panel	Duration
146	04:09	2	01:00

NO PANEL

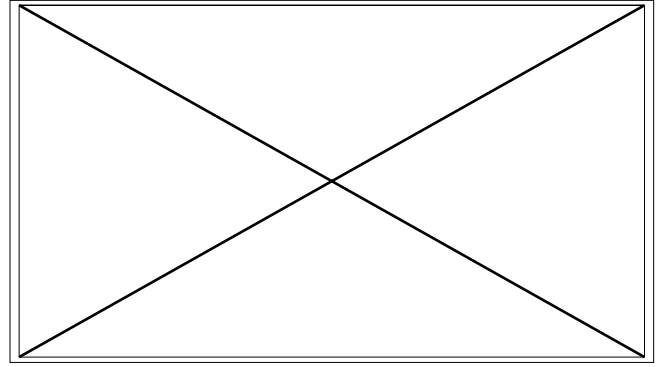
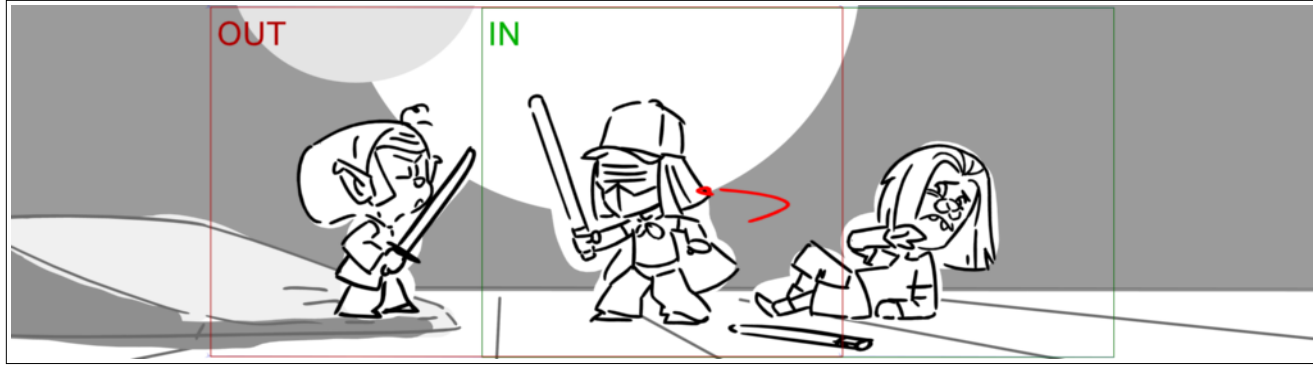

Action Notes

Tom se retourne vers Jojo

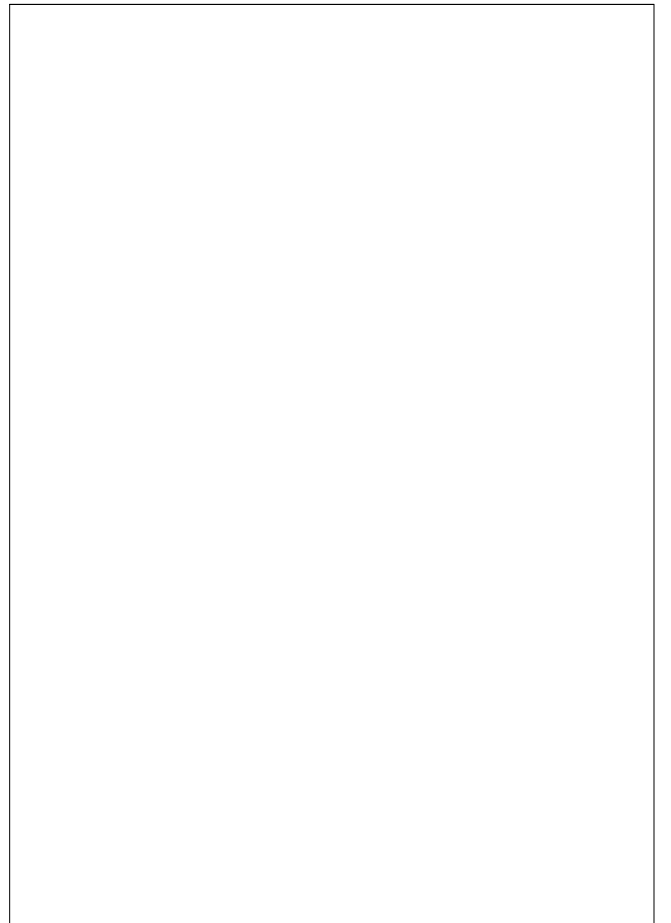



Scene	Duration	Panel	Duration
146	04:09	3	00:18

NO PANEL

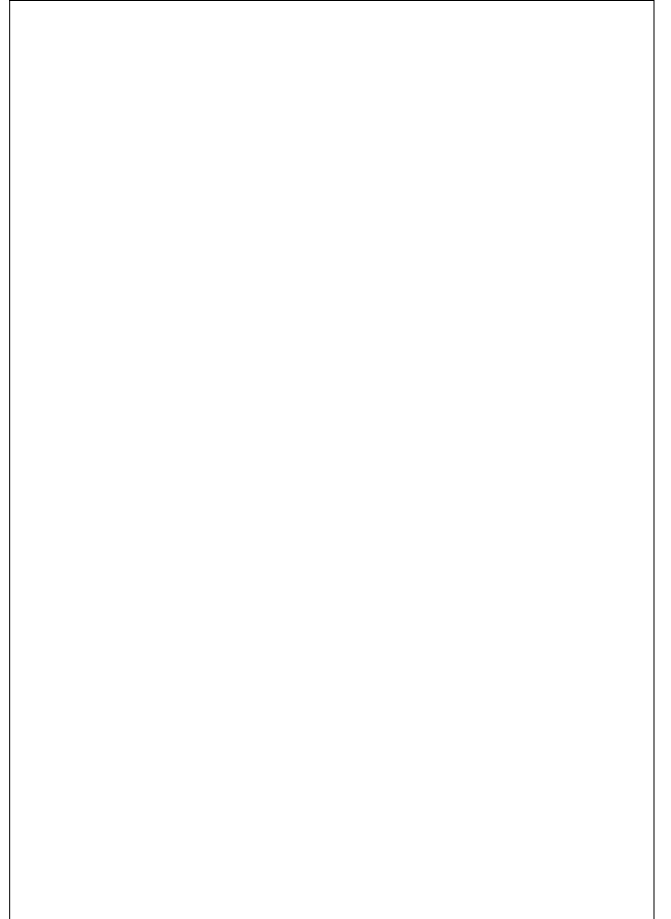
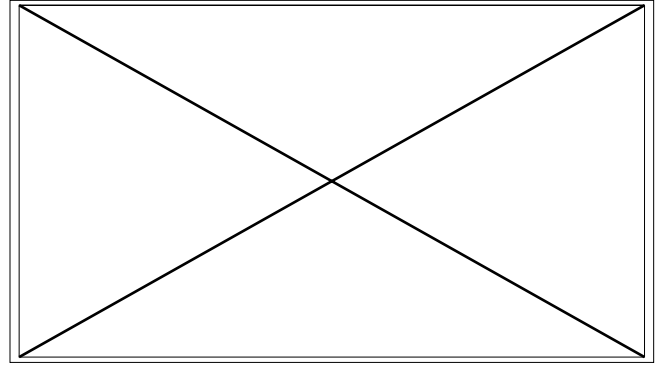
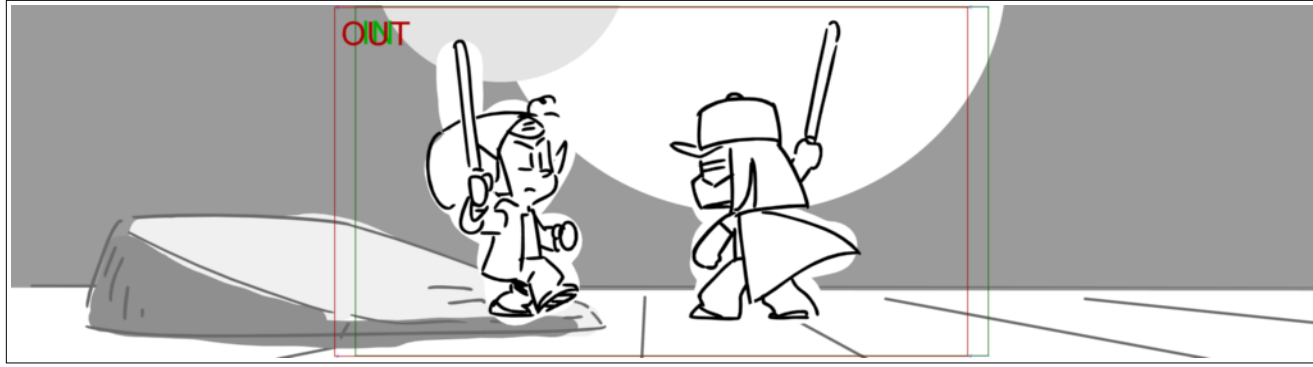



Scene	Duration	Panel	Duration
146	04:09	4	00:14

NO PANEL

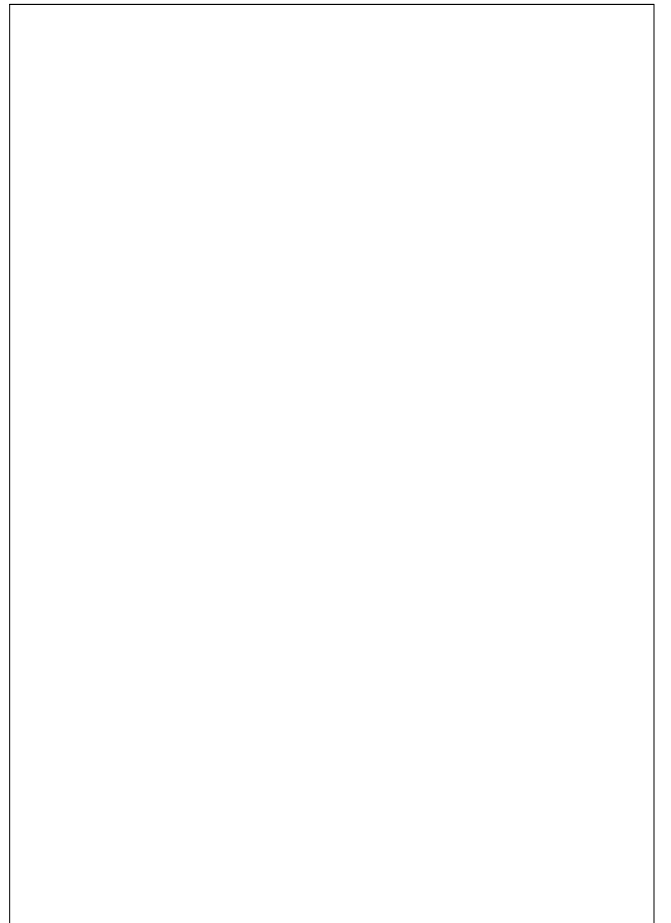
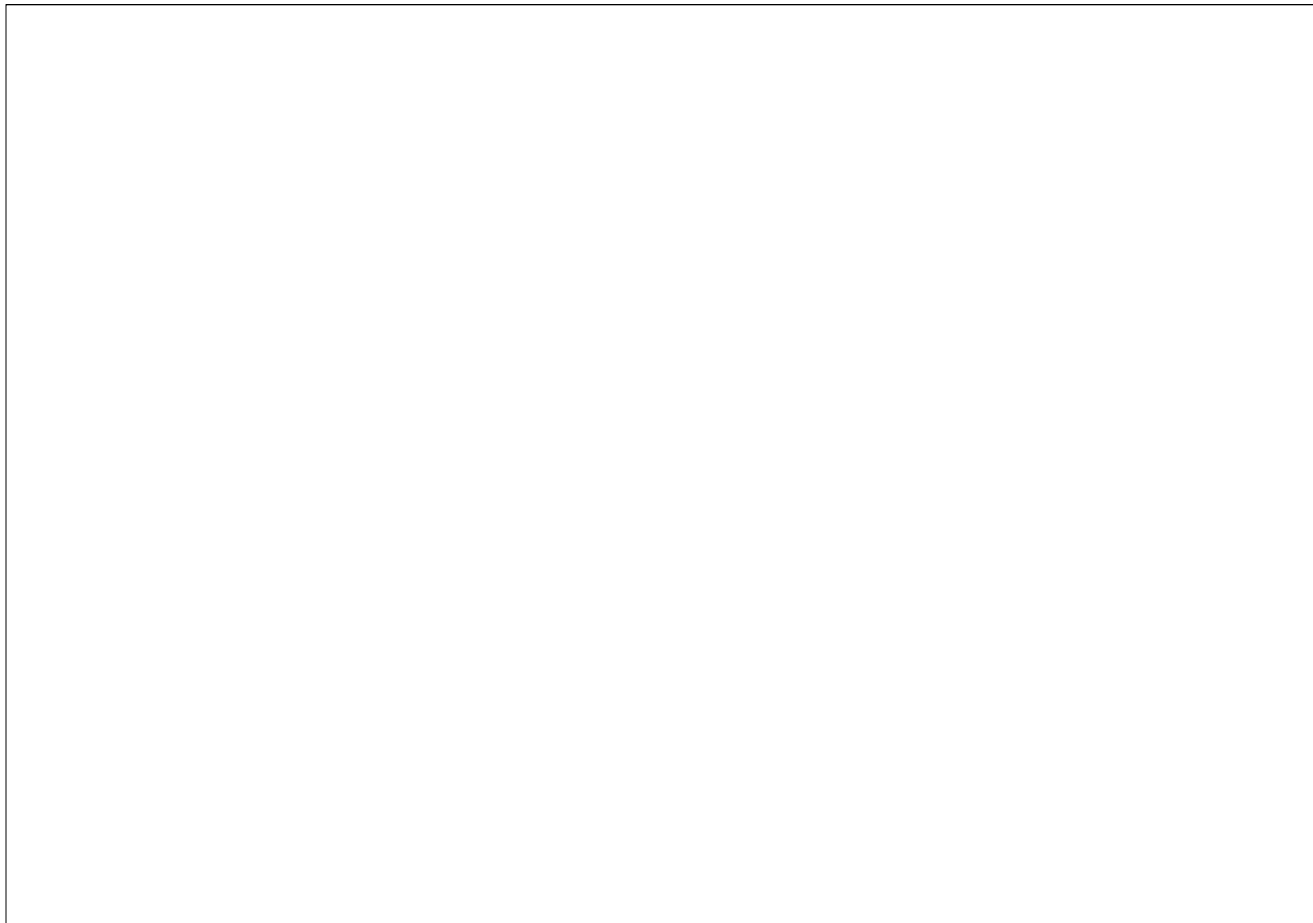
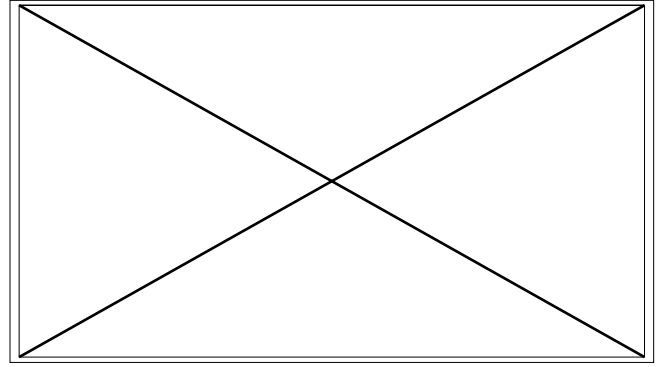
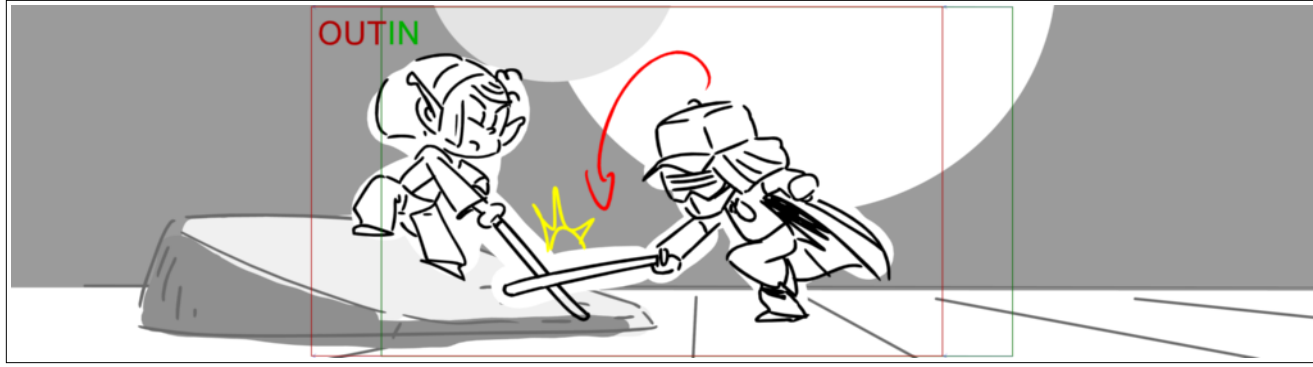

Scene	Duration	Panel	Duration
146	04:09	5	01:02



Scene	Duration	Panel	Duration
147	10:09	1	01:00

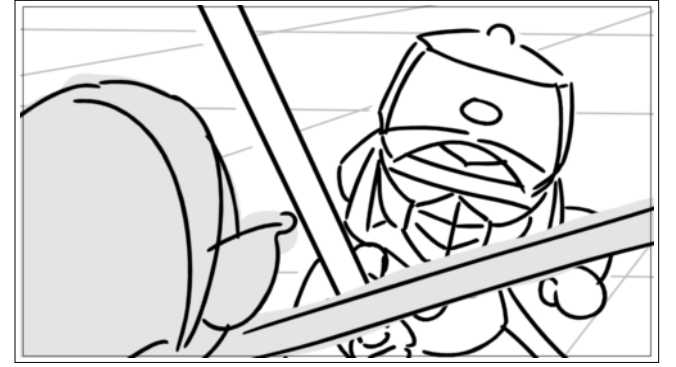

Dialogue

81. Tom DARK VAPOR/VOIX DE GREGOR
Yoga,

Scene	Duration	Panel	Duration
147	10:09	2	03:22

Scene	Duration	Panel	Duration
147	10:09	3	00:15

Scene	Duration	Panel	Duration
147	10:09	4	00:14

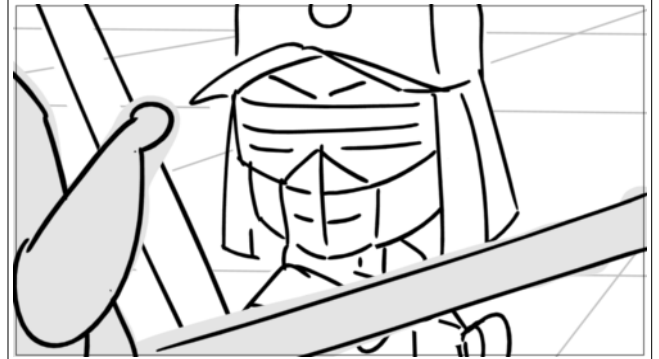
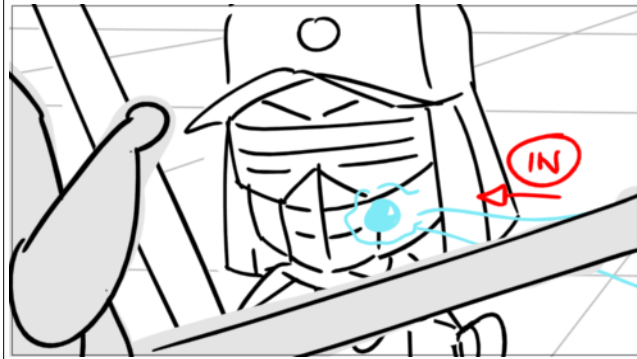
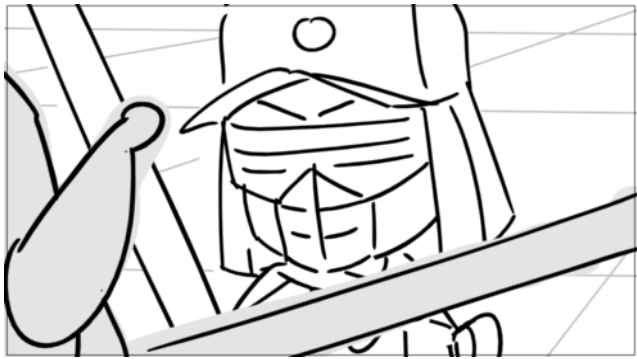

Dialogue
 81. Tom DARK VAPOR/VOIX DE GREGOR
 c'est toi qui a empêché mon fils de
 basculer...

Dialogue
 Le FX atteind Tom

Dialogue
 TOM Hic!

Action Notes
 Tom a le Hoquet

Scene	Duration	Panel	Duration
147	10:09	5	01:12

Scene	Duration	Panel	Duration
147	10:09	6	01:14

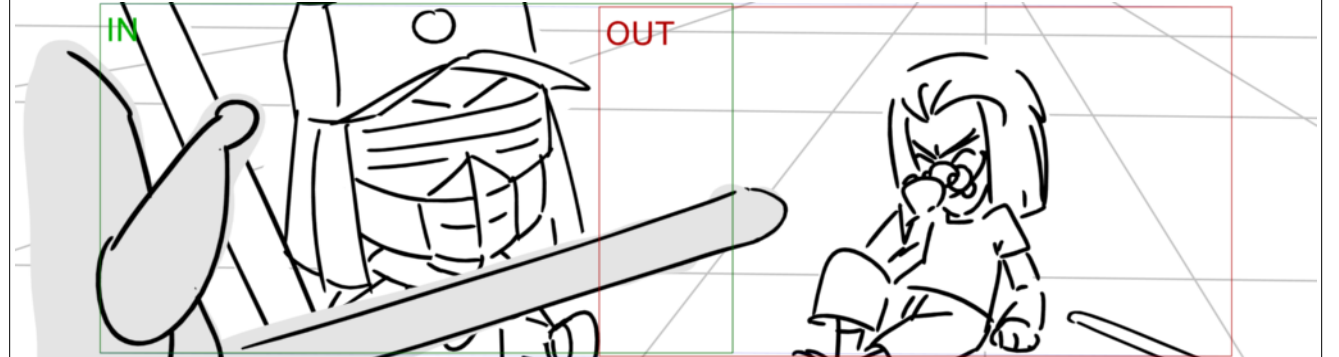

Dialogue

84. VICTOR (rire étouffé)
Pfffaahahahah...

Action Notes

A l'arrière Victor pouffe

Scene	Duration	Panel	Duration
147	10:09	7	01:07

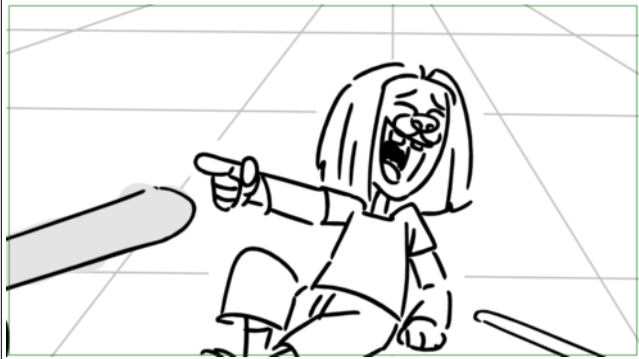

Dialogue

84. VICTOR (rire étouffé)
Pfffaahahahah...

Scene	Duration	Panel	Duration
148	02:00	1	01:00

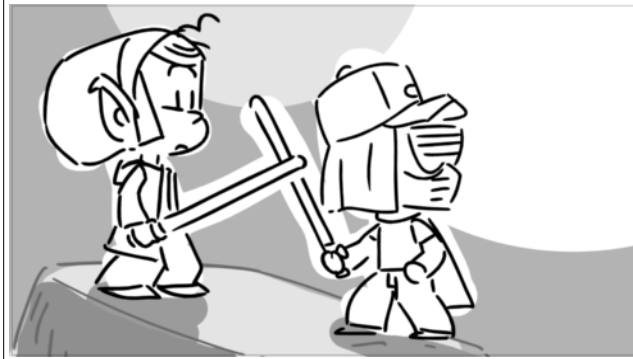

Scene	Duration	Panel	Duration
148	02:00	2	01:00

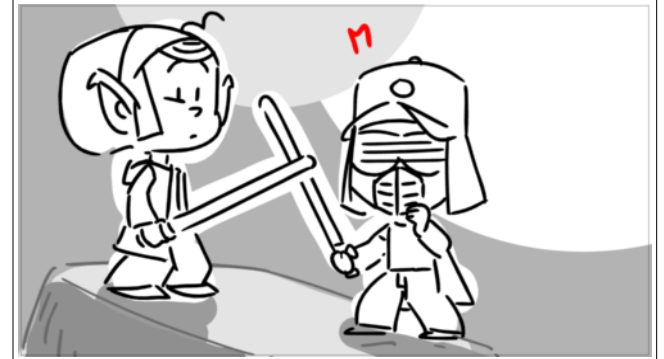

Dialogue

82. Tom DARK VAPOR / VOIX TOM
(pour lui)
Oh non ! Ma voix...

Scene	Duration	Panel	Duration
149	03:18	1	03:18



Scene	Duration	Panel	Duration
150	04:09	1	01:00



Scene	Duration	Panel	Duration
150	04:09	2	03:09



Dialogue

86. Mlle FOSSETTE
 (soufflant) Je suis le terrible Dark Vapor venu des ténèbres.

Action Notes

Mlle Fossette souffle le texte à Tom

Scene	Duration	Panel	Duration
151	02:24	1	00:21



Dialogue

87. Tom DARK VAPOR / VOIX TOM (reprend toujours mal à l'aise)
Je suis le terrible Dark Vapor...

Scene	Duration	Panel	Duration
151	02:24	2	01:05



Dialogue

<Plusieurs rires fusent>

Scene	Duration	Panel	Duration
151	02:24	3	00:23



Dialogue

<Plusieurs rires fusent>

Scene	Duration	Panel	Duration
152	02:22	1	00:17



Dialogue

89. LE PÈRE DE VICTOR
<rire moqueur>

Scene	Duration	Panel	Duration
152	02:22	2	00:14



Dialogue

89. LE PÈRE DE VICTOR
<rire moqueur>

Scene	Duration	Panel	Duration
152	02:22	3	01:05



Dialogue
 GREGOR
 <grognement super fort> Tu te moques de mon fils?

Scene	Duration	Panel	Duration
152	02:22	4	00:11



Scene	Duration	Panel	Duration
153	02:04	1	00:15



Scene	Duration	Panel	Duration
153	02:04	2	01:14



Dialogue
85. Willow
Vas-y Tom !

Scene	Duration	Panel	Duration
154	02:10	1	00:09

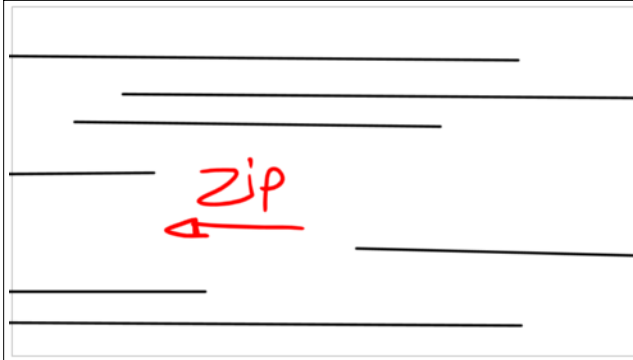

Scene	Duration	Panel	Duration
154	02:10	2	00:13





Scene	Duration	Panel	Duration
154	02:10	3	00:13



Scene	Duration	Panel	Duration
154	02:10	4	01:00



Scene	Duration	Panel	Duration
155	01:20	1	00:17



Action Notes

Découragé Tom retire son masque

Scene	Duration	Panel	Duration
155	01:20	2	00:10



Action Notes

le regard de Tom s'illumine

Scene	Duration	Panel	Duration
155	01:20	3	00:18



Dialogue

PU TOM
Mais oui!

Action Notes

il a une idée

Scene	Duration	Panel	Duration
156	04:19	1	00:12

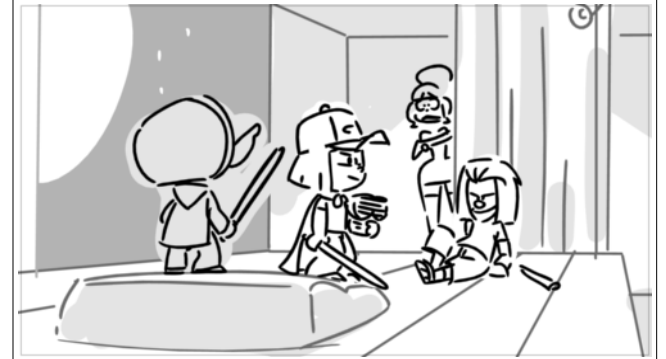

Scene	Duration	Panel	Duration
156	04:19	2	00:13



Dialogue

88. Tom (reprend, très enjoué)
Je ne suis pas le terrible Dark Vapor
venu des ténèbres..

Scene	Duration	Panel	Duration
156	04:19	3	00:12

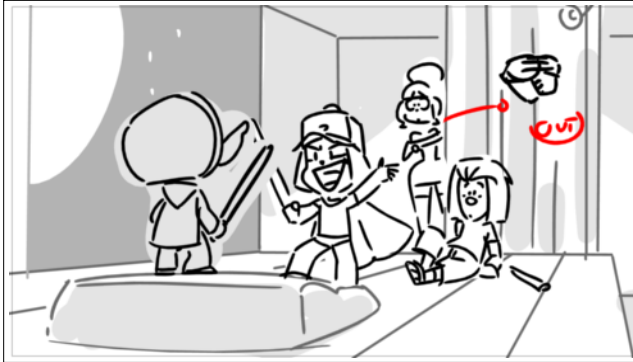

Dialogue

88. Tom (reprend, très enjoué)
Je ne suis pas le terrible Dark Vapor
venu des ténèbres..

Scene	Duration	Panel	Duration
156	04:19	4	03:07



Dialogue

88. Tom (reprend, très enjoué)
Je ne suis pas le terrible Dark Vapor
venu des ténèbres..

Scene	Duration	Panel	Duration
157	06:00	1	01:22



Dialogue
 90. jojo (déstabilisé)
 Ah ? Heu...

Scene	Duration	Panel	Duration
157	06:00	2	01:08



Dialogue
 90. jojo (déstabilisé)
 t'es qui alors ?

Scene	Duration	Panel	Duration
157	06:00	3	01:16



Dialogue
 91. Tom
 Quoi ? Tu ne me reconnais pas...

Scene	Duration	Panel	Duration
157	06:00	4	00:16



Dialogue
 91. Tom
 Quoi ? Tu ne me reconnais pas...

Scene	Duration	Panel	Duration
157	06:00	5	00:13



Dialogue
 91. Tom
 Quoi ? Tu ne me reconnais pas...

Scene	Duration	Panel	Duration
158	03:08	1	01:01

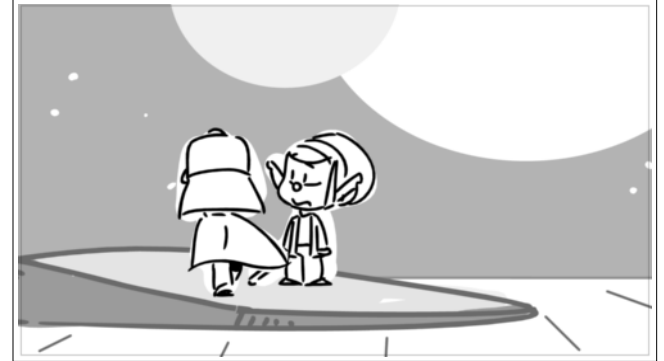

Dialogue
 91. Tom
 JE SUIS...



Scene	Duration	Panel	Duration
158	03:08	2	00:23

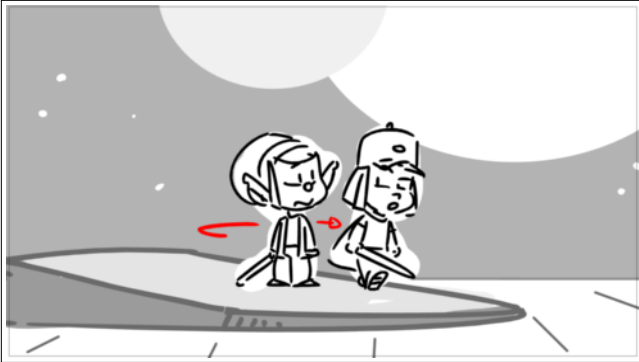

Dialogue

91. Tom
JE SUIS...

Scene	Duration	Panel	Duration
158	03:08	3	01:04



Dialogue

91. Tom
JE SUIS...

Scene	Duration	Panel	Duration
158	03:08	4	00:05



Dialogue

91. Tom
JE SUIS...



Scene	Duration	Panel	Duration
159	01:19	1	00:18

NO PANEL

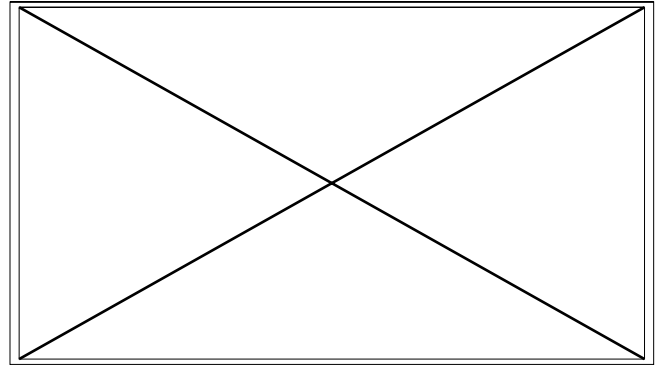
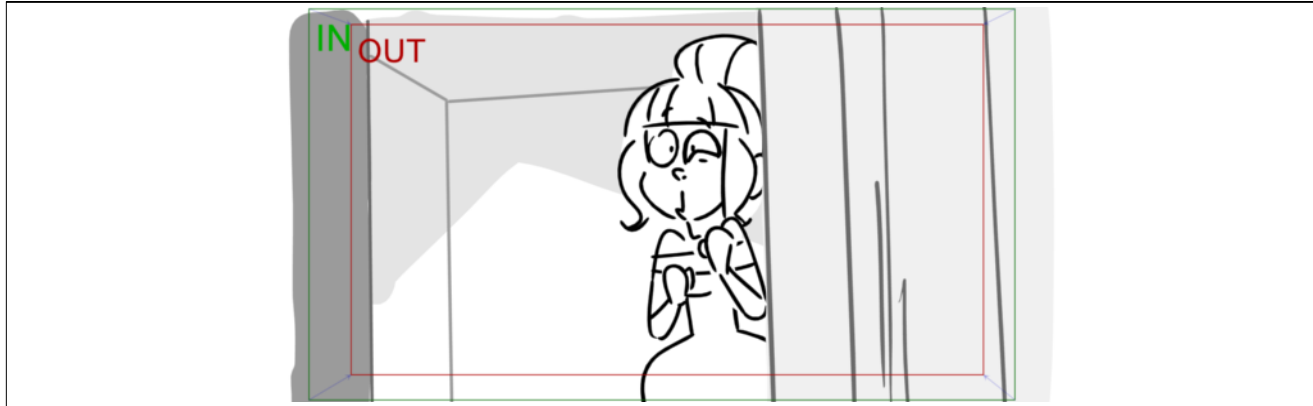

Dialogue
91. Tom
JE SUIS... JE SUIS...

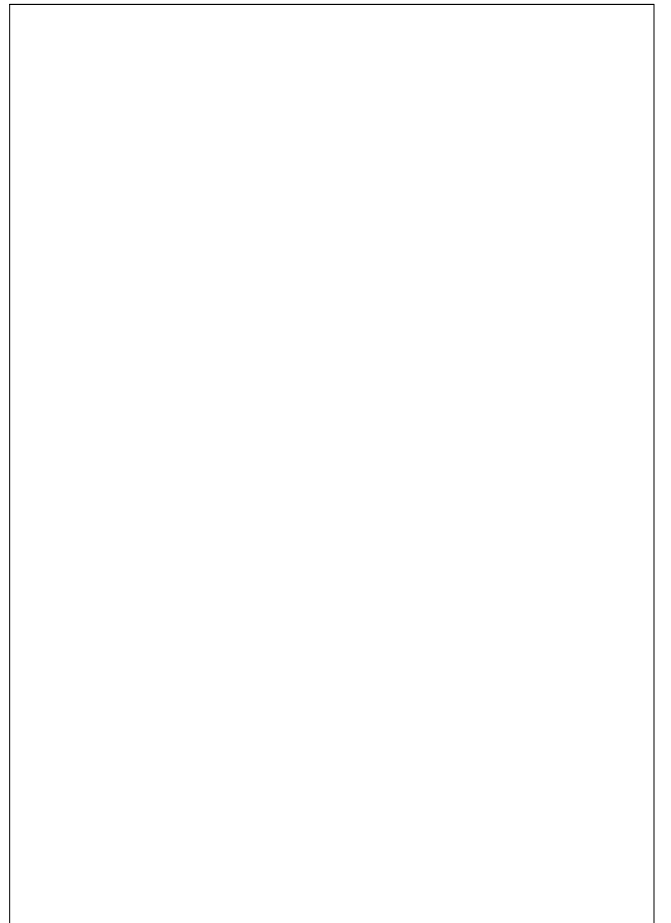



Scene	Duration	Panel	Duration
159	01:19	2	01:01

NO PANEL

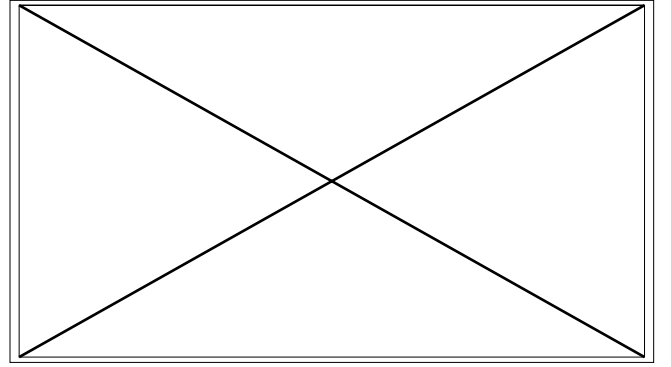
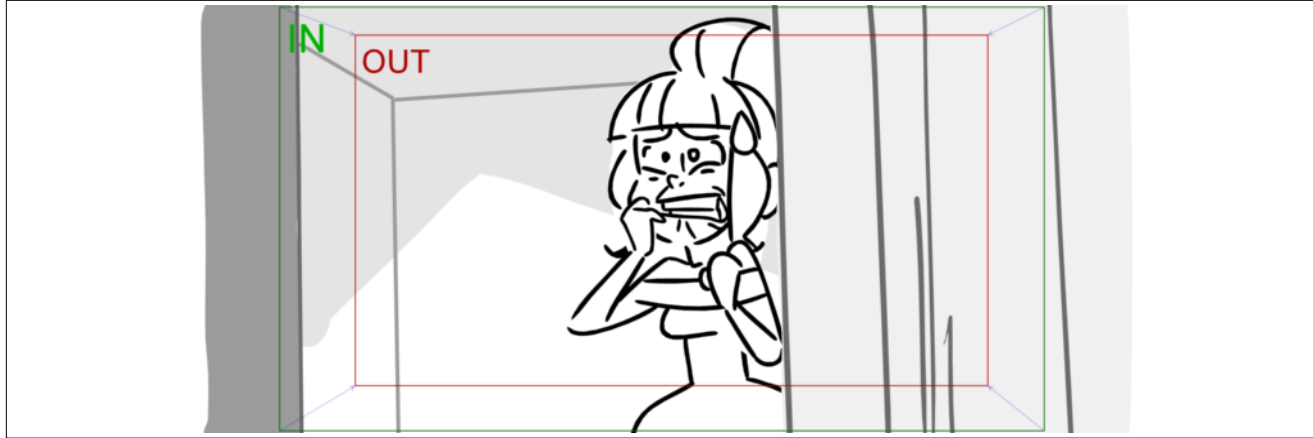

Dialogue
91. Tom
JE SUIS... JE SUIS...

Action Notes
Mlle Fossette se ronge les ongles,

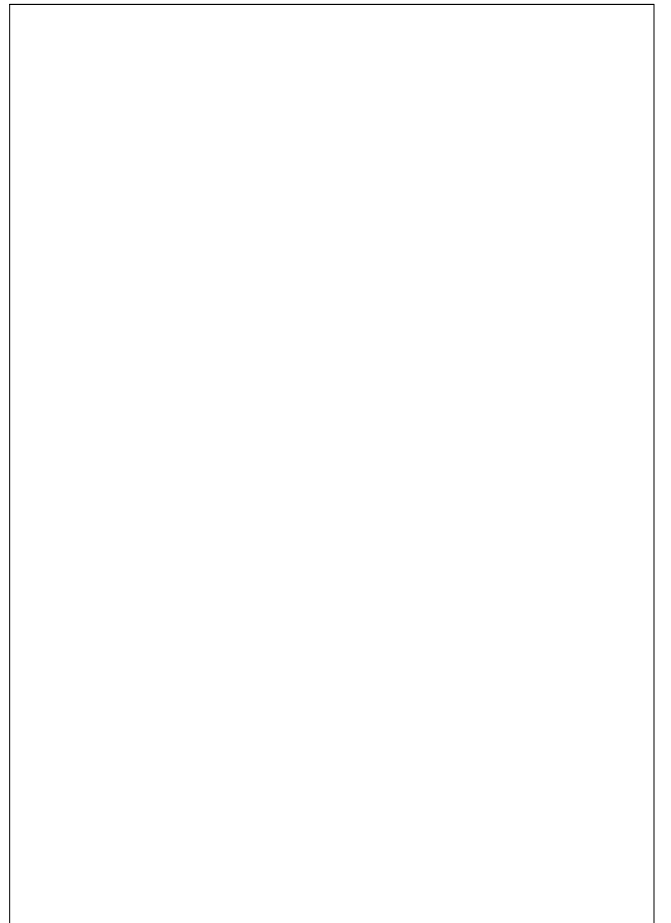

Scene	Duration	Panel	Duration
160	01:00	1	01:00

NO PANEL

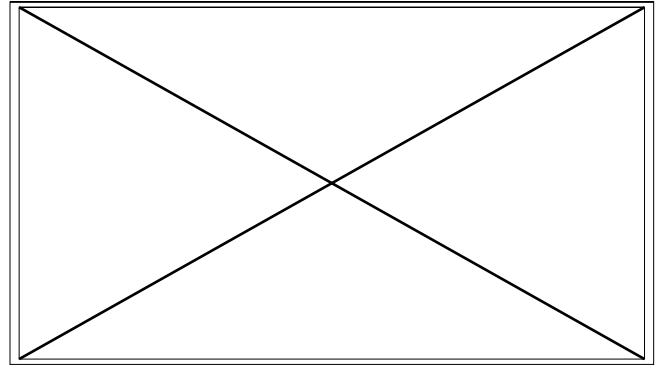

Dialogue
91. Tom
JE SUIS... JE SUIS...

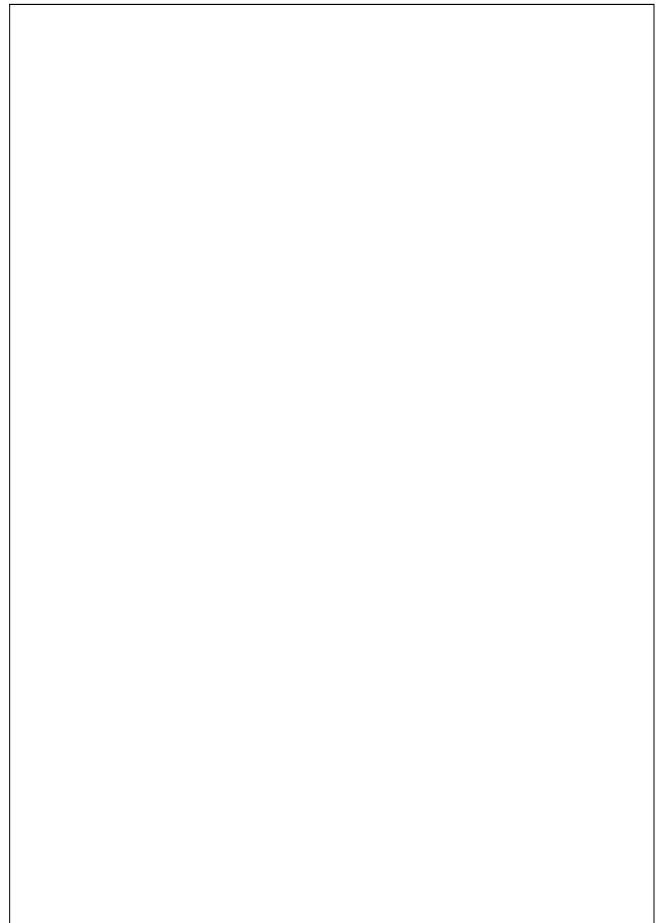

Scene	Duration	Panel	Duration
161	02:17	1	01:00

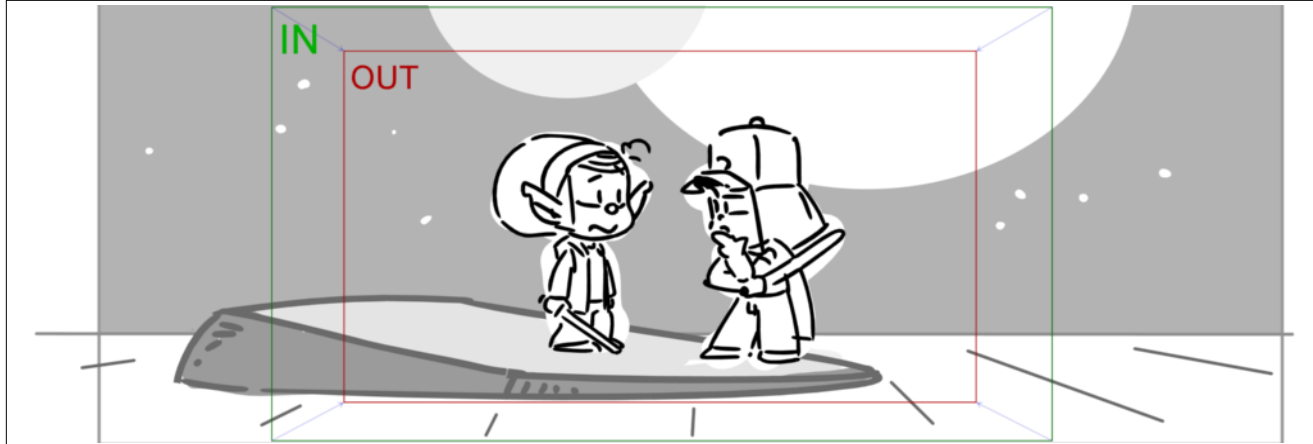

Dialogue
 91. Tom
 JE SUIS... JE SUIS...

Scene	Duration	Panel	Duration
161	02:17	2	01:00



Dialogue
 91. Tom
 TON FILS !!!

Scene	Duration	Panel	Duration
161	02:17	3	00:17



Scene	Duration	Panel	Duration
162	01:13	1	01:13



Action Notes

Flottement dans la salle.

Scene	Duration	Panel	Duration
163	06:21	1	01:00



Dialogue

92. jojo (hésitant)
Si tu es mon fils...

Scene	Duration	Panel	Duration
163	06:21	2	01:11



Dialogue
 92. jojo (hésitant)
 Si tu es mon fils...

Scene	Duration	Panel	Duration
163	06:21	3	01:19



Dialogue
 92. jojo (hésitant)
 ça veut dire que je suis...

Scene	Duration	Panel	Duration
163	06:21	4	01:03



Dialogue
 92. jojo (hésitant)
 ton père ?

Scene	Duration	Panel	Duration
163	06:21	5	00:13

Scene	Duration	Panel	Duration
163	06:21	6	00:12

Scene	Duration	Panel	Duration
163	06:21	7	00:13

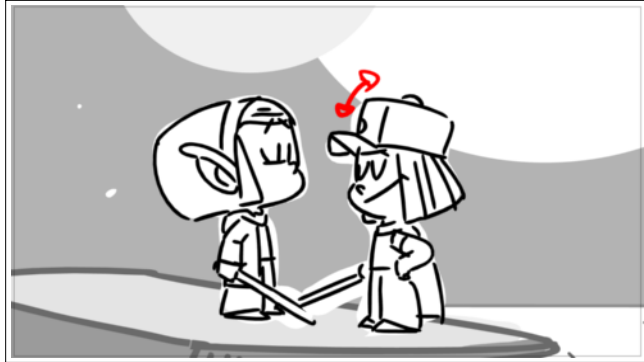
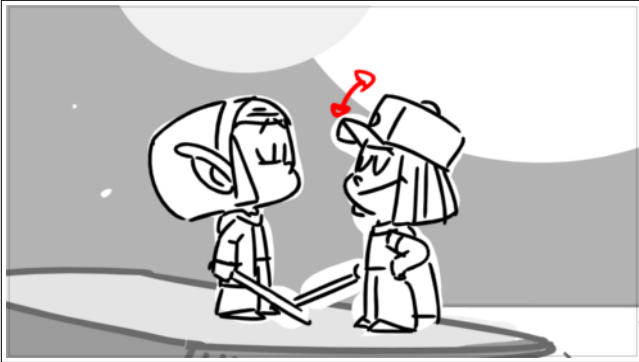

Action Notes

Tom opine

Dialogue

93. PUBLIC
<RIRES>

Scene	Duration	Panel	Duration
164	01:11	1	01:11



Dialogue
93. PUBLIC
<RIRES>

Scene	Duration	Panel	Duration
165	03:11	1	00:09



Dialogue
93. PUBLIC
<RIRES>

Scene	Duration	Panel	Duration
165	03:11	2	01:17



Dialogue
PU Mlle FOSSETTE
PFIOU!

Action Notes
Mlle fossette soulagée

Scene	Duration	Panel	Duration
165	03:11	3	01:10



Dialogue

94. TOM
Et avec toi Papounet,

Scene	Duration	Panel	Duration
166	03:20	1	02:06



Dialogue

94. TOM
on va redécouper la Galaxie au sabre laser !

Scene	Duration	Panel	Duration
166	03:20	2	01:14



Dialogue

94. TOM
on va redécouper la Galaxie au sabre laser !

Scene	Duration	Panel	Duration
167	01:00	1	01:00



Dialogue
SFX BRAVO!!!!

Scene	Duration	Panel	Duration
168	04:00	1	01:00



Dialogue
SFX BRAVO!!!!

Scene	Duration	Panel	Duration
168	04:00	2	01:00



Dialogue
SFX BRAVO!!!!



Scene	Duration	Panel	Duration
168	04:00	3	01:00

Scene	Duration	Panel	Duration
168	04:00	4	01:00

NO PANEL

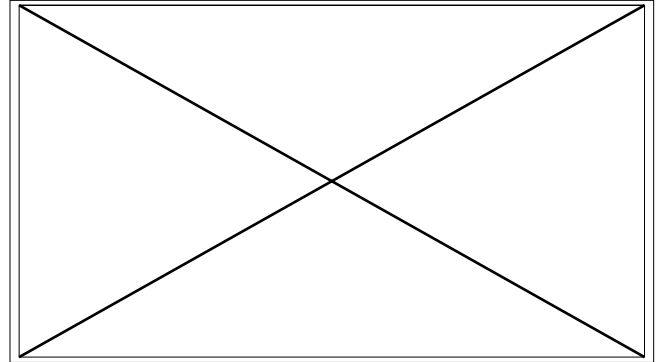
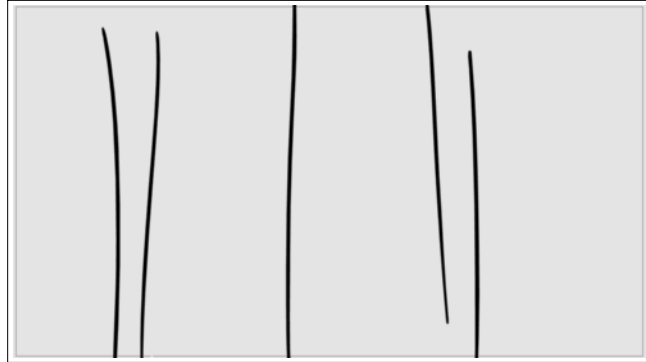
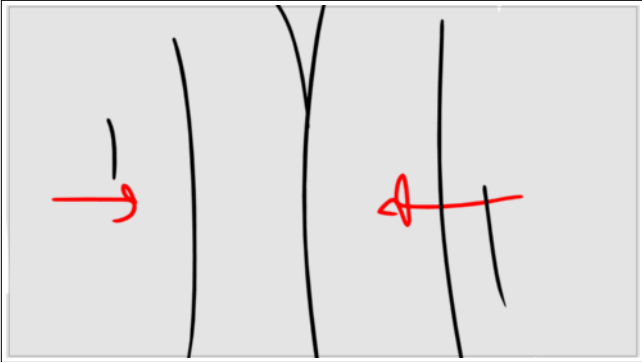

Dialogue
SFX BRAVO!!!!

Dialogue
SFX BRAVO!!!!



Scene	Duration	Panel	Duration
169	02:19	1	00:07

NO PANEL

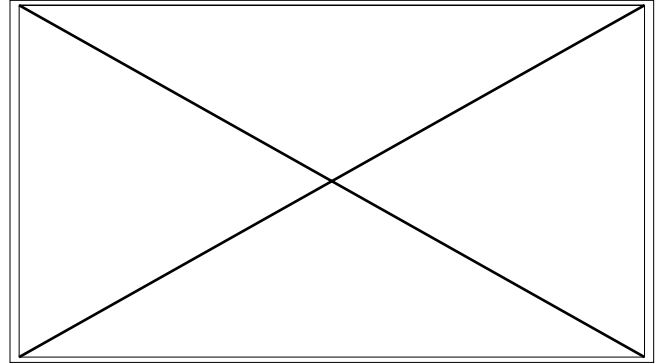
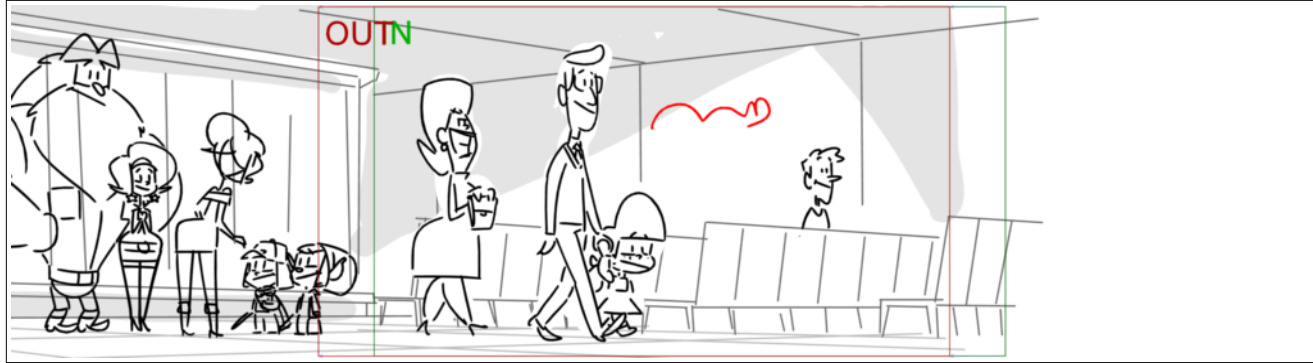

Action Notes

La salle se vide,

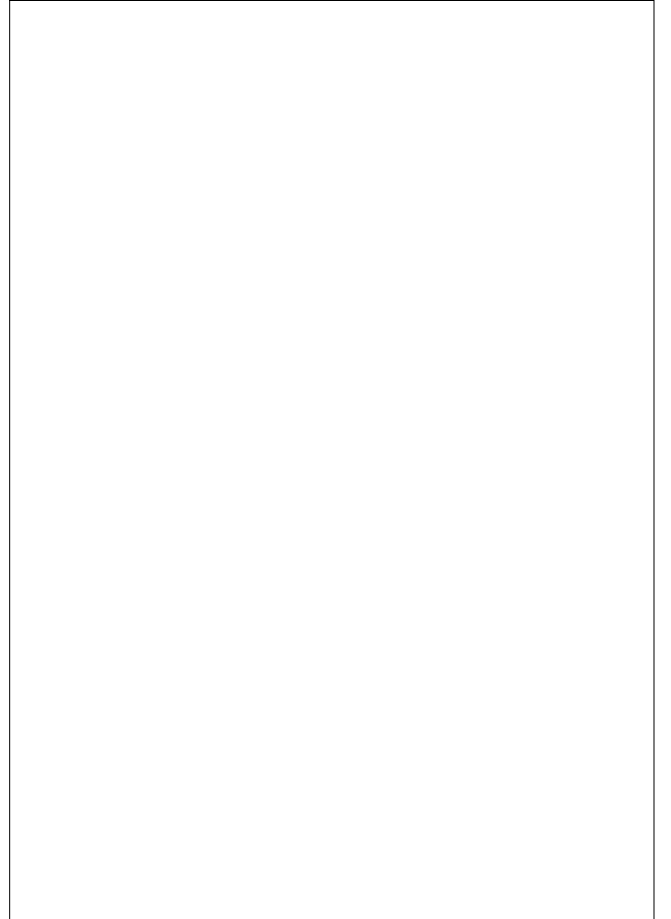

Scene	Duration	Panel	Duration
169	02:19	2	01:24

Scene	Duration	Panel	Duration
169	02:19	3	00:13

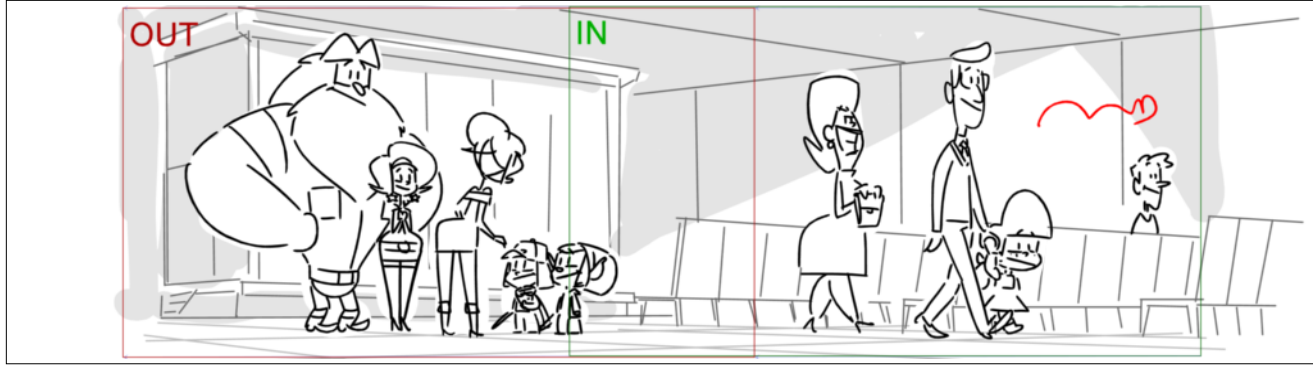

Dialogue
 95. Mlle Fossette
 Bravo Tom !

Dialogue
 95. Mlle Fossette
 Bravo Tom !

Action Notes
 PAN

Scene	Duration	Panel	Duration
170	02:00	1	00:16



Dialogue
 95. Mlle Fossette
 Très drôle ton improvisation !

Action Notes
 Mlle Fossette fait un clin d'oeil à Tom

Scene	Duration	Panel	Duration
170	02:00	2	01:09



Dialogue
 95. Mlle Fossette
 Très drôle ton improvisation !

Scene	Duration	Panel	Duration
171	06:13	1	01:12



Dialogue
 96. Tom
 Je crois que finalement,

Scene	Duration	Panel	Duration
171	06:13	2	00:24



Dialogue

96. Tom
je l'aime bien ma voix.

Action Notes

Victor passe IN/OUT

Scene	Duration	Panel	Duration
171	06:13	3	02:05



Dialogue

96. Tom
Je veux bien la garder encore quelques années...

Scene	Duration	Panel	Duration
171	06:13	4	01:04

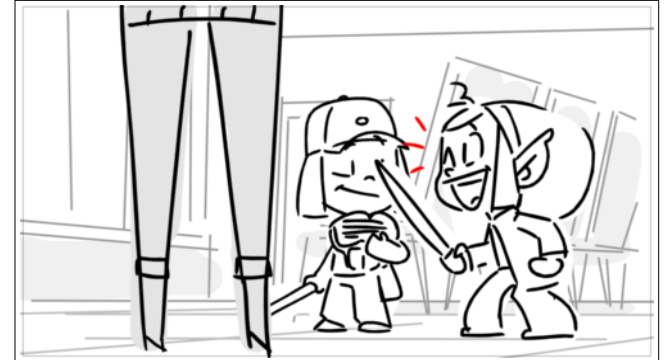

Dialogue

97. JOJO (imitant Choubaba)
Moi aussi !

Scene	Duration	Panel	Duration
171	06:13	5	00:08



Dialogue
 97. JOJO (imitant Choubaba)
 Moi aussi !

Scene	Duration	Panel	Duration
171	06:13	6	00:10



Dialogue
 97. JOJO (imitant Choubaba)
 Moi aussi !

Scene	Duration	Panel	Duration
172	03:07	1	00:12



Scene	Duration	Panel	Duration
172	03:07	2	00:09



Scene	Duration	Panel	Duration
172	03:07	3	01:18



Dialogue

97. JOJO (imitant Choubaba)
Raouuuuugraaaaahhh !!!

Scene	Duration	Panel	Duration
172	03:07	4	00:09



Dialogue

PU VICTOR
Ahhhh!

Scene	Duration	Panel	Duration
172	03:07	5	00:09



Dialogue

PU VICTOR
Ahhhh!

Scene	Duration	Panel	Duration
173	01:17	1	00:09

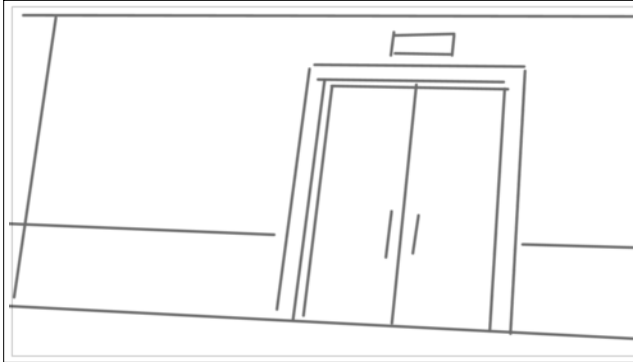

Dialogue

PU VICTOR
Ahhhh!

Scene	Duration	Panel	Duration
173	01:17	2	00:13



Dialogue

PU VICTOR
Ahhhh!



Scene	Duration	Panel	Duration
173	01:17	3	00:10



Scene	Duration	Panel	Duration
173	01:17	4	00:10

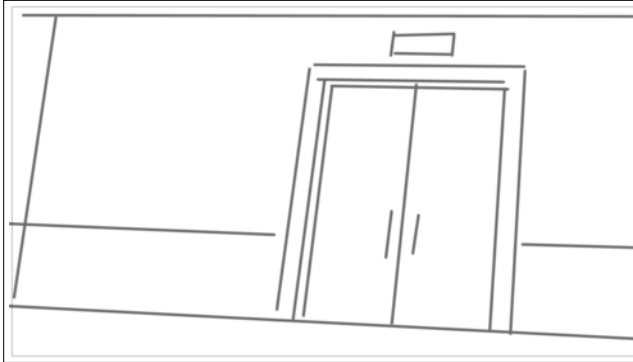

Scene	Duration	Panel	Duration
174	04:19	1	00:14

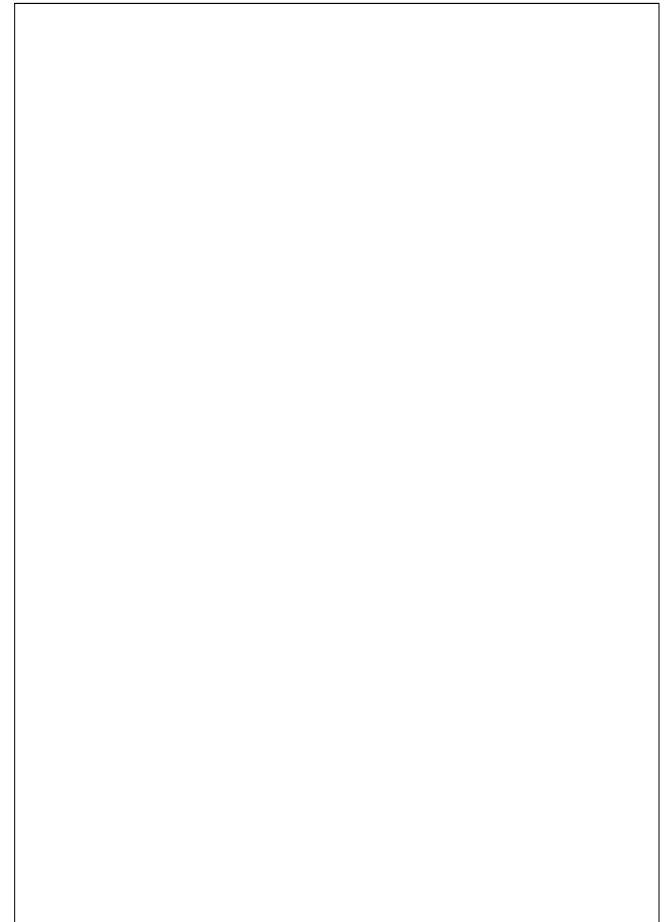
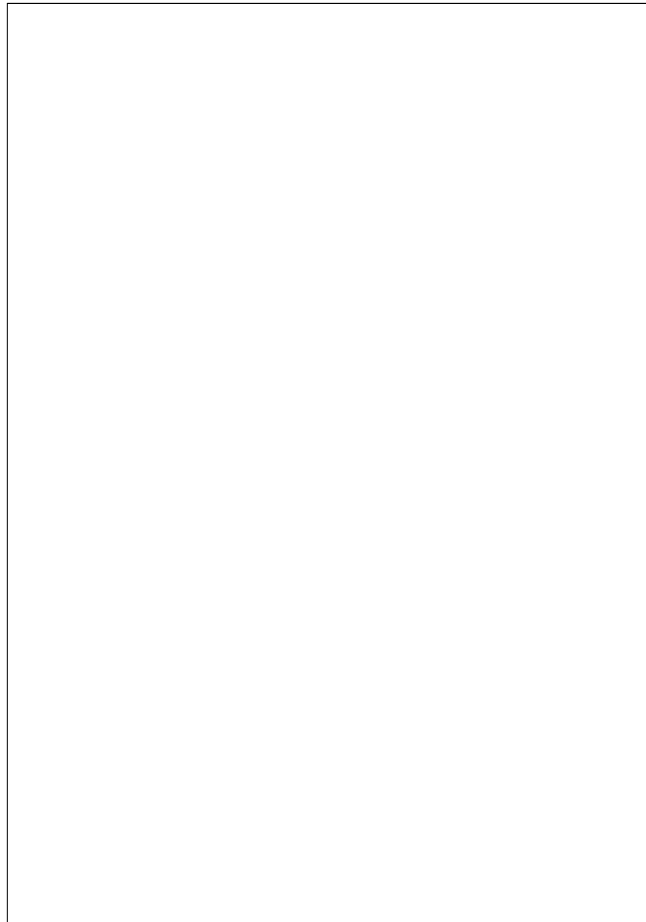
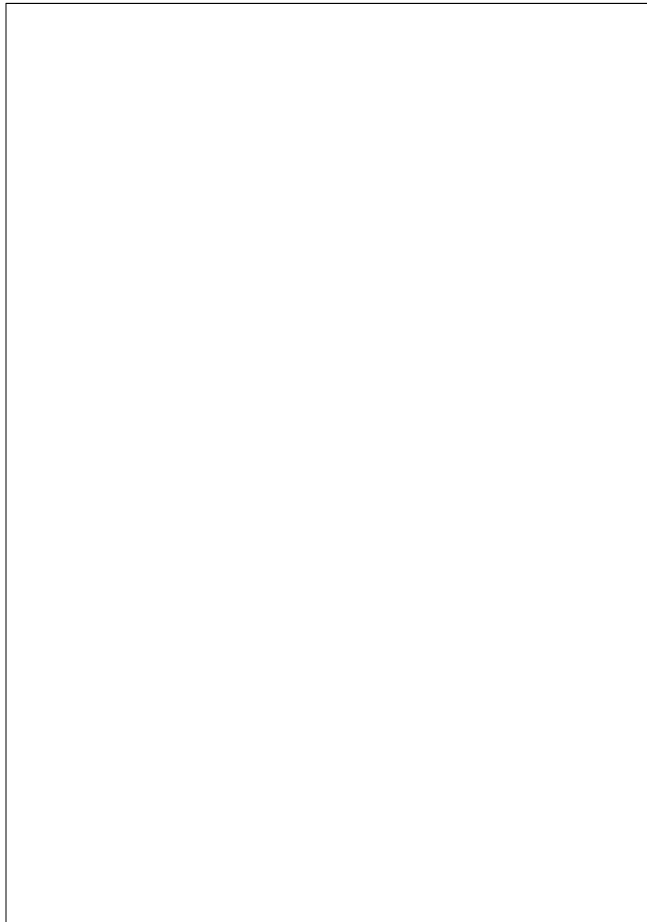



Scene	Duration	Panel	Duration
174	04:19	2	01:00



Dialogue

98. TOUS
<RIRES>

Scene	Duration	Panel	Duration
174	04:19	3	03:05



Dialogue

98. TOUS
<RIRES>

Scene	Duration	Panel	Duration
175	01:00	1	01:00

