

CA_162_Le_Colorimoi
t
out

Scene	Duration	Panel	Duration
001	08:09	1	04:05

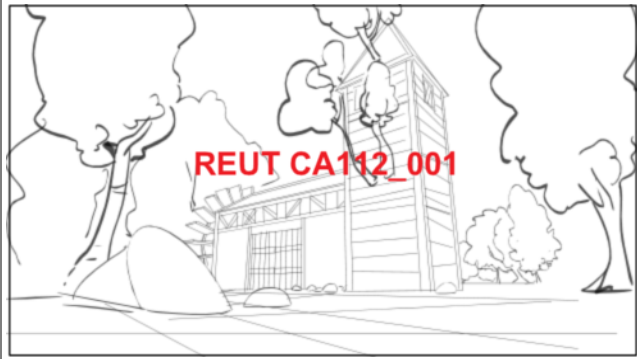

Action Notes

1. MOULIN ?EXT. JOUR

Scene	Duration	Panel	Duration
001	08:09	2	02:10

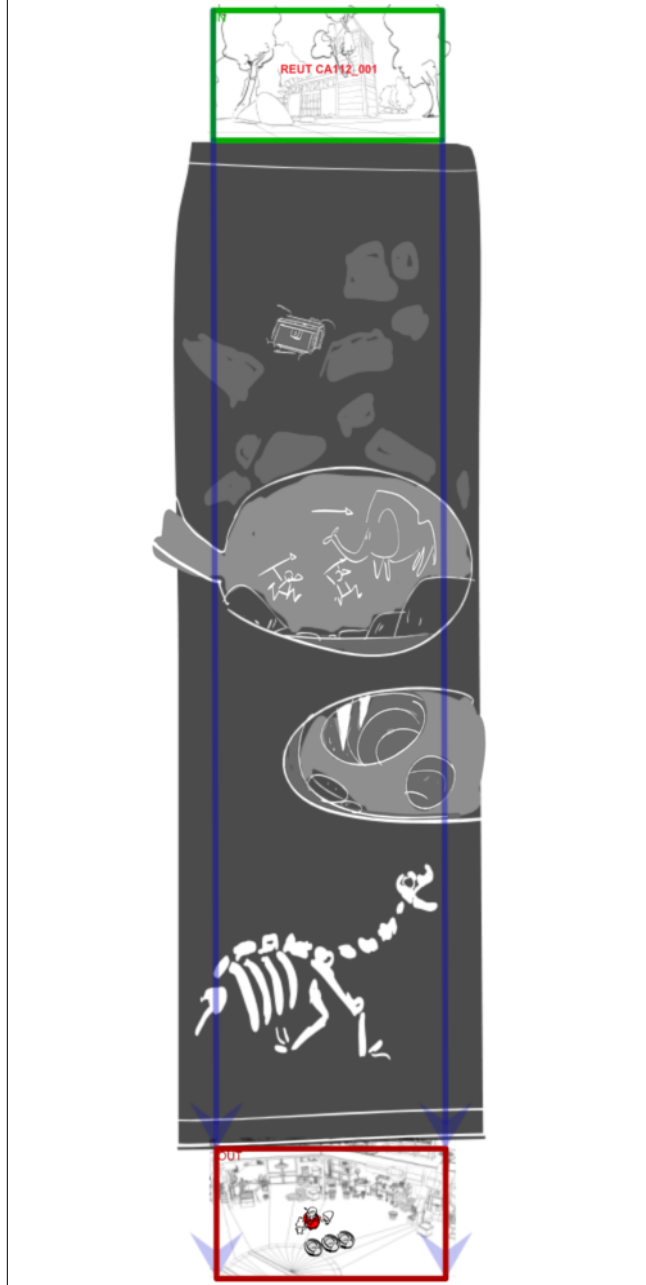

Scene	Duration	Panel	Duration
001	08:09	3	01:19

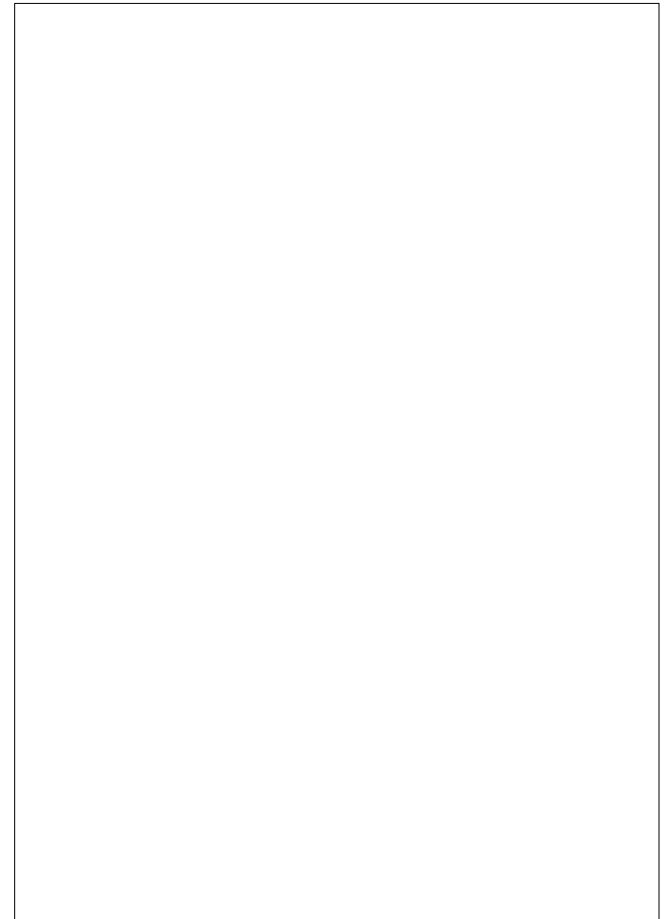



Scene	Duration	Panel	Duration
002	05:19	1	00:14

Scene	Duration	Panel	Duration
002	05:19	2	00:12

Scene	Duration	Panel	Duration
002	05:19	3	01:00

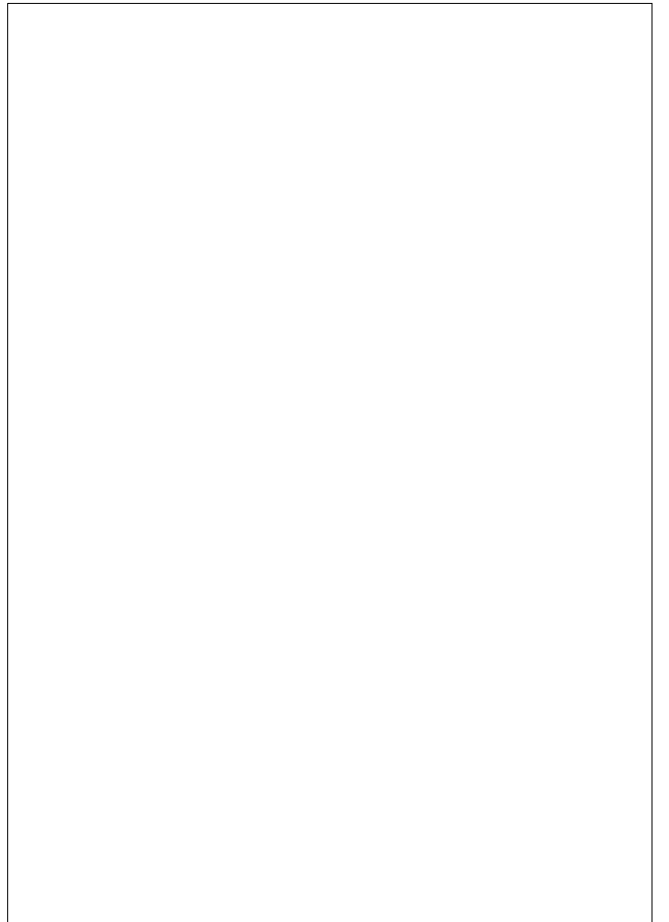
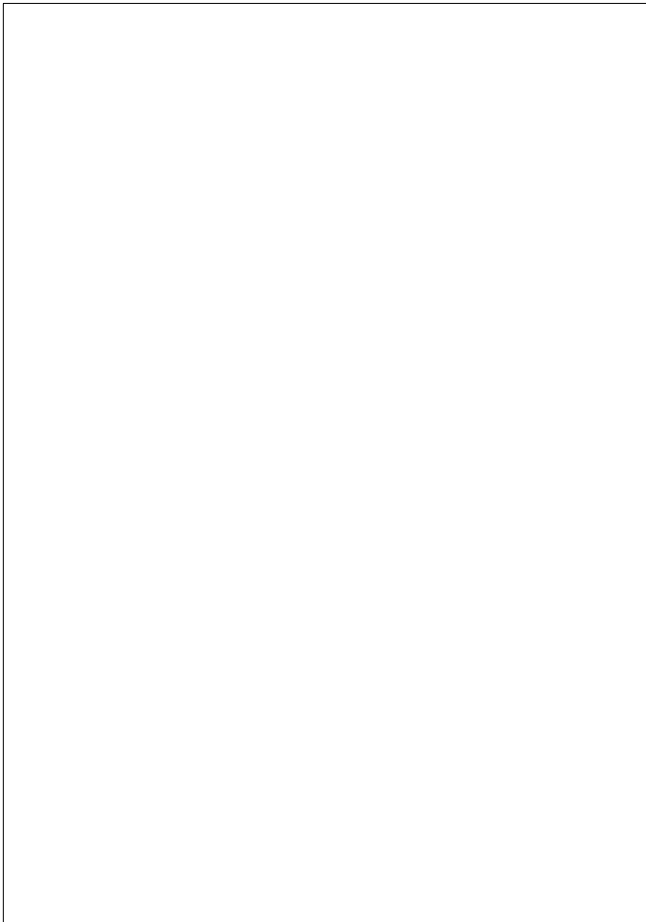
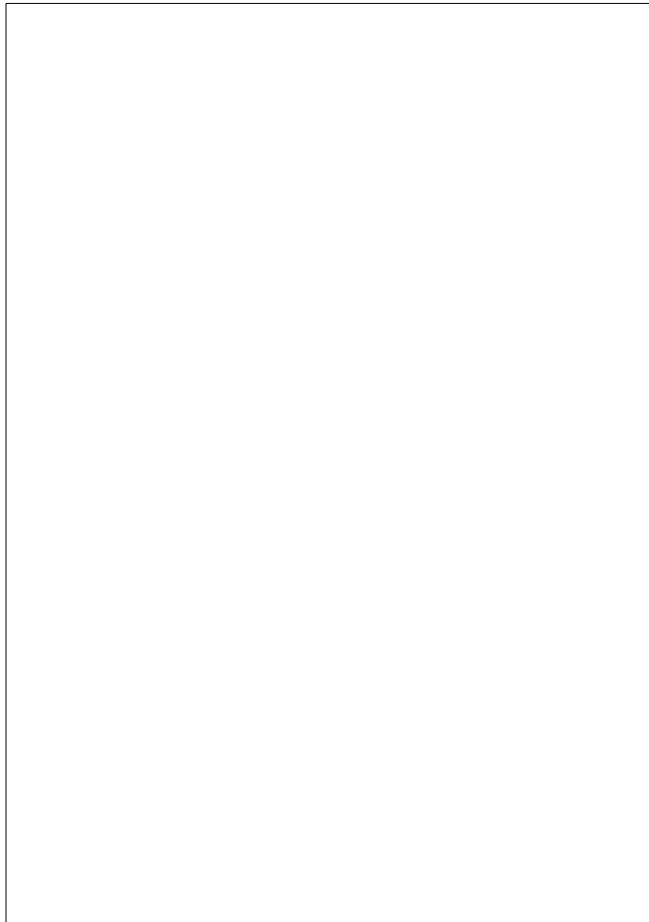

Scene	Duration	Panel	Duration
002	05:19	4	00:11

Scene	Duration	Panel	Duration
002	05:19	5	00:09

Scene	Duration	Panel	Duration
002	05:19	6	00:11

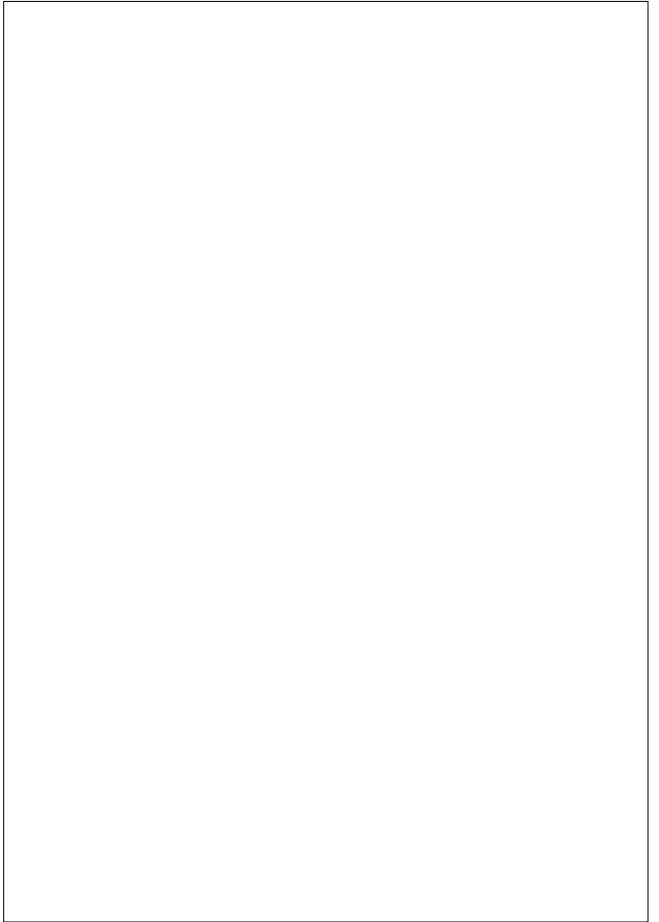
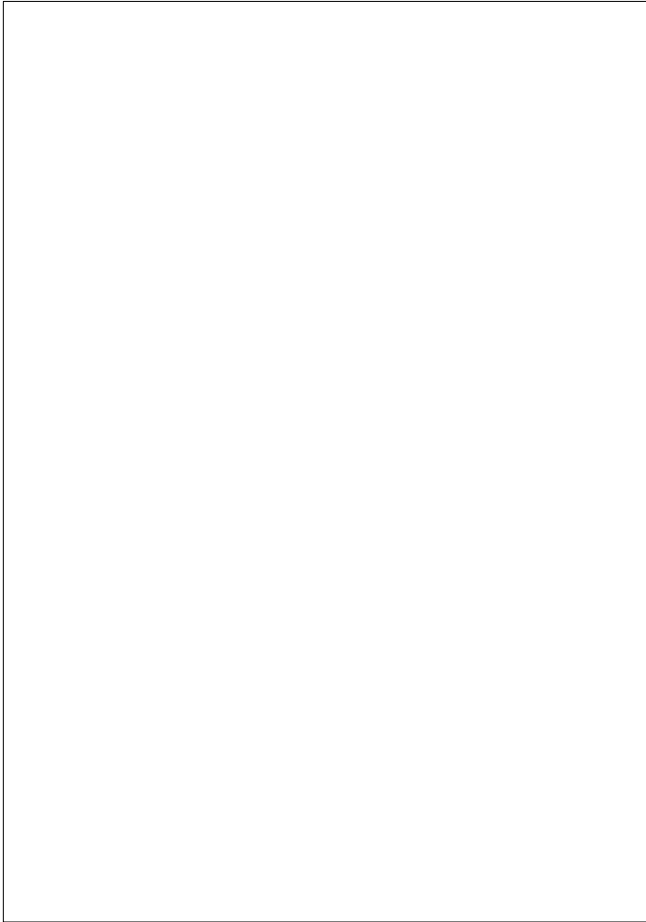
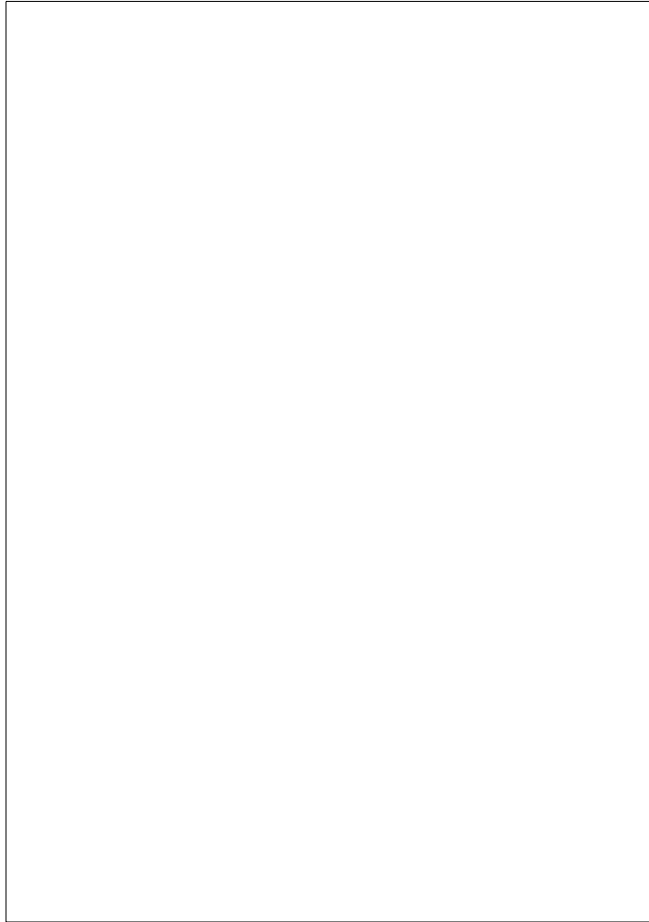



Scene	Duration	Panel	Duration
002	05:19	7	00:09

Scene	Duration	Panel	Duration
002	05:19	8	00:11

Scene	Duration	Panel	Duration
002	05:19	9	00:09

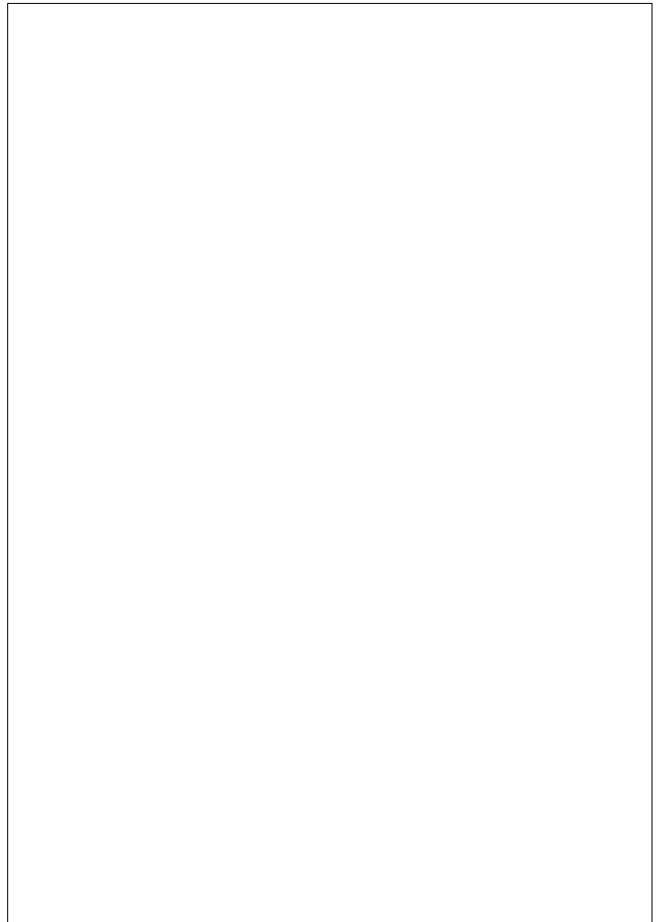
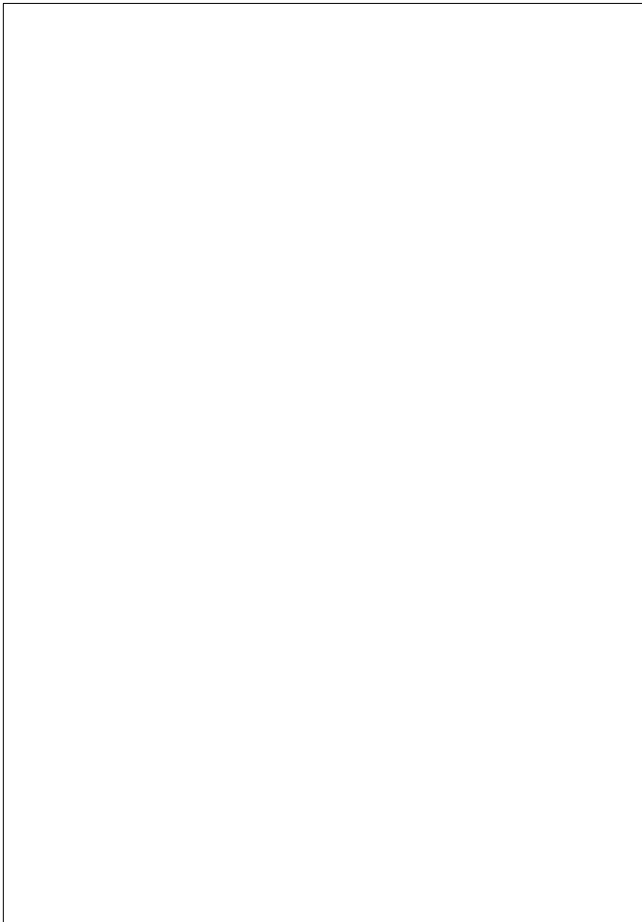
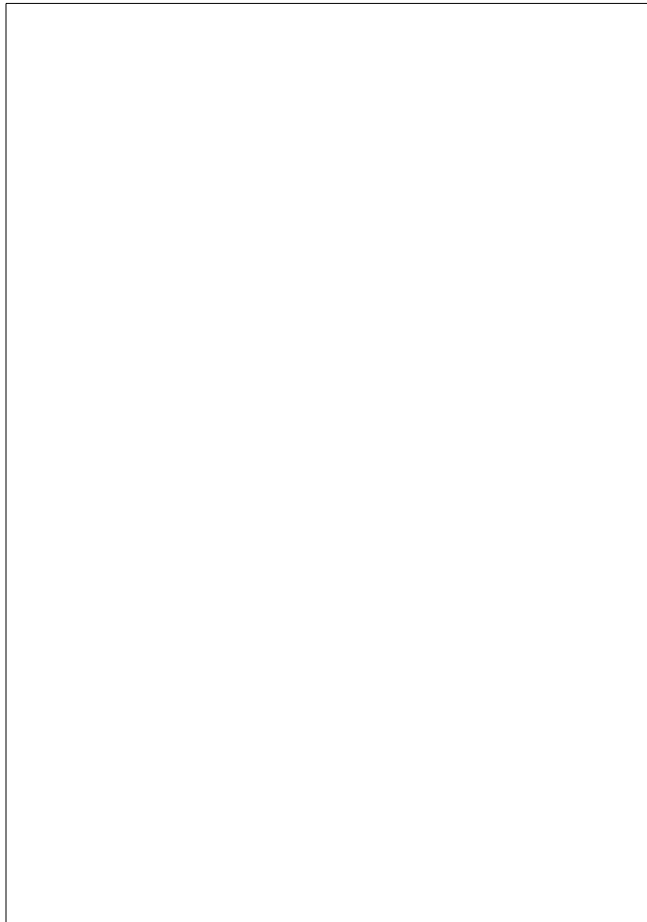

Scene	Duration	Panel	Duration
002	05:19	10	01:00



Dialogue

1. CALIMERO (enjoué)
Et voilà !

Scene	Duration	Panel	Duration
002	05:19	11	00:08



Scene	Duration	Panel	Duration
003	08:07	1	01:00

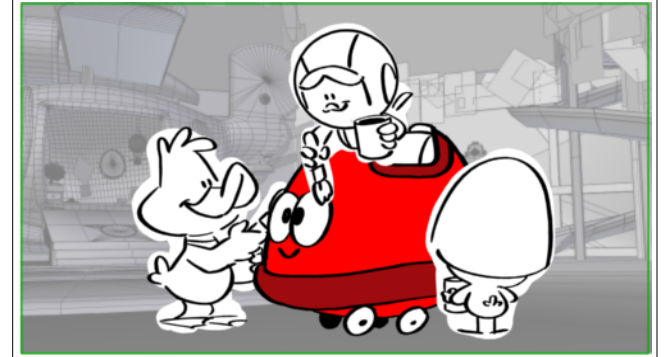

Dialogue

1. CALIMERO MODIF (enjoué)
Il n' y a plus que les pois noirs à faire

Action Notes

Caliméro, Valériano et Pierrot (de dos) donnent un dernier coup de pinceau sur une auto-tamponneuse rouge qui a la forme d'une coccinelle.

Scene	Duration	Panel	Duration
003	08:07	2	01:00

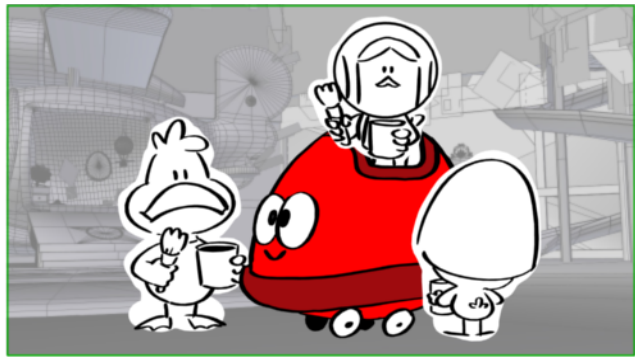

Dialogue

1. CALIMERO MODIF (enjoué)
Il n' y a plus que les pois noirs à faire

Scene	Duration	Panel	Duration
003	08:07	3	00:14

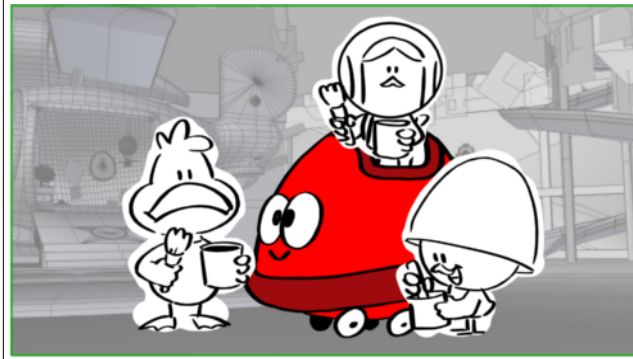

Dialogue

1. CALIMERO MODIF (enjoué)
et nous aurons une belle coccinelle !

Scene	Duration	Panel	Duration
003	08:07	4	01:10

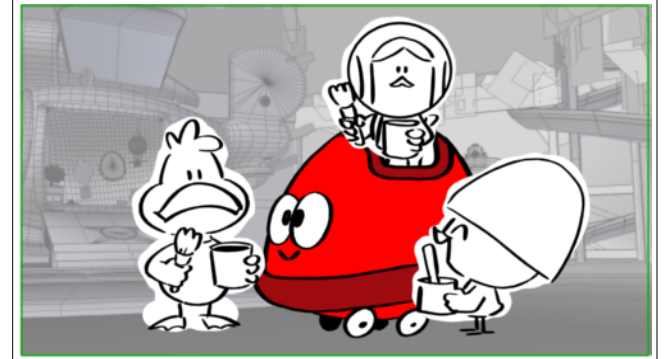

Dialogue

1. CALIMERO MODIF (enjoué)
et nous aurons une belle coccinelle !

Scene	Duration	Panel	Duration
003	08:07	5	01:00

Scene	Duration	Panel	Duration
003	08:07	6	00:16

Scene	Duration	Panel	Duration
003	08:07	7	00:08

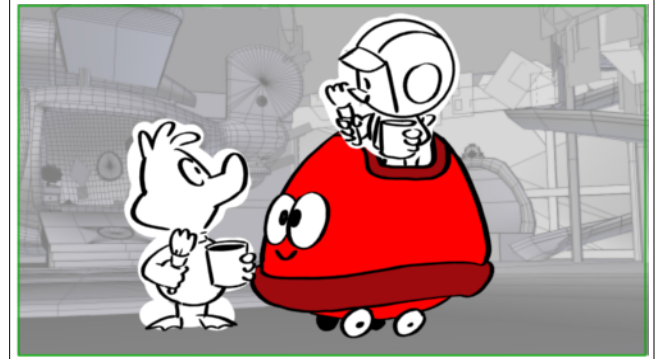
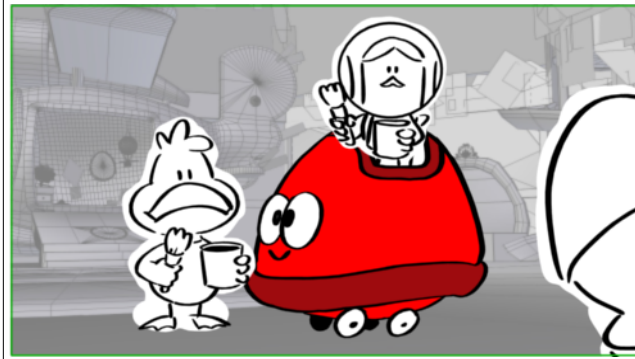
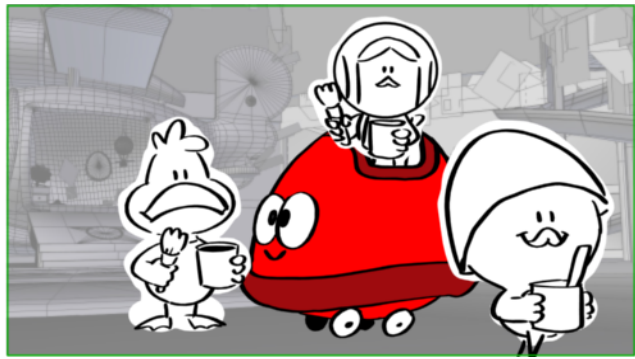

Dialogue
 PICK UP PIERROT
 Quoi?

Scene	Duration	Panel	Duration
003	08:07	8	00:06

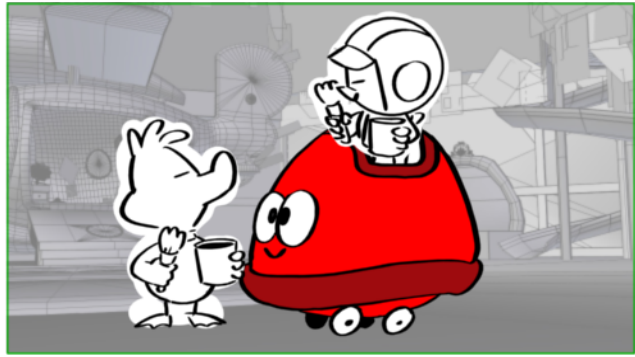

Scene	Duration	Panel	Duration
003	08:07	9	00:16

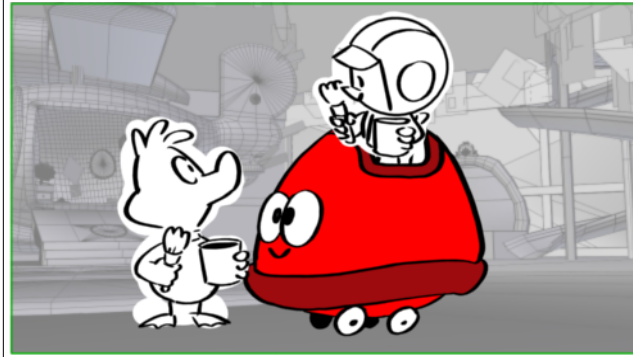

Scene	Duration	Panel	Duration
003	08:07	10	01:12

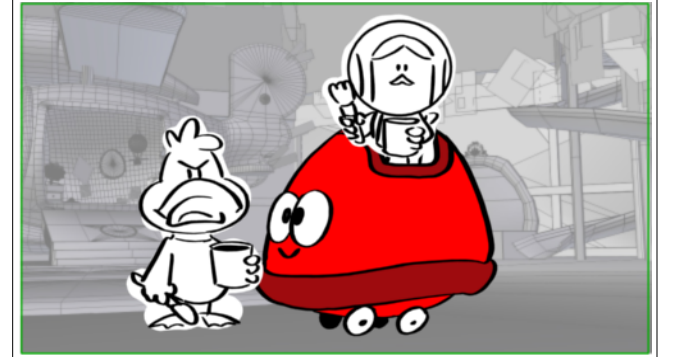

Dialogue

2. PIERROT

C?était pas prévu, ça !

Scene	Duration	Panel	Duration
004	03:19	1	00:13

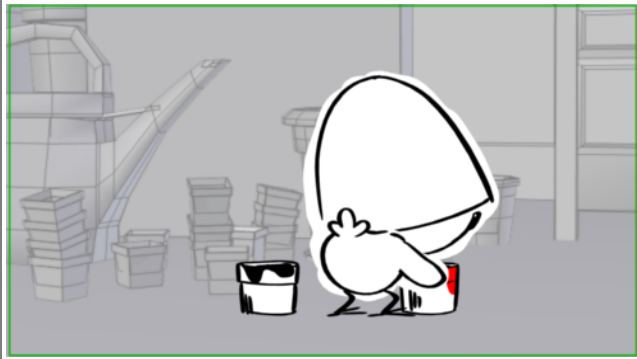

Dialogue
 2. PIERROT
 C'est quoi encore cette histoire de coccinelle?!

Scene	Duration	Panel	Duration
004	03:19	2	00:15



Dialogue
 2. PIERROT
 C'est quoi encore cette histoire de coccinelle?!

Scene	Duration	Panel	Duration
004	03:19	3	00:15



Dialogue
 2. PIERROT
 C'est quoi encore cette histoire de coccinelle?!

Action Notes
 calimero prend un pot de peinture noire

Scene	Duration	Panel	Duration
004	03:19	4	00:17

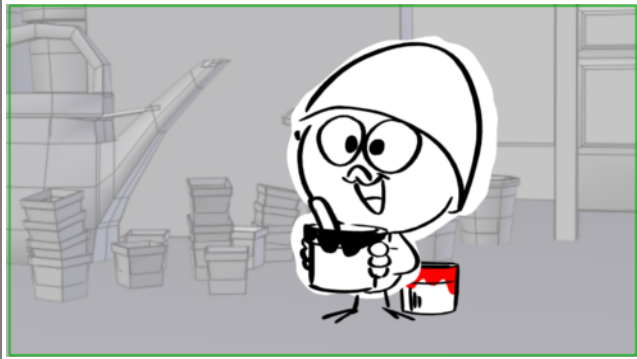

Dialogue

3. CALIMERO (se dirigeant vers un pot de peinture noire)
Mais si Pierrot,

Scene	Duration	Panel	Duration
004	03:19	5	00:20

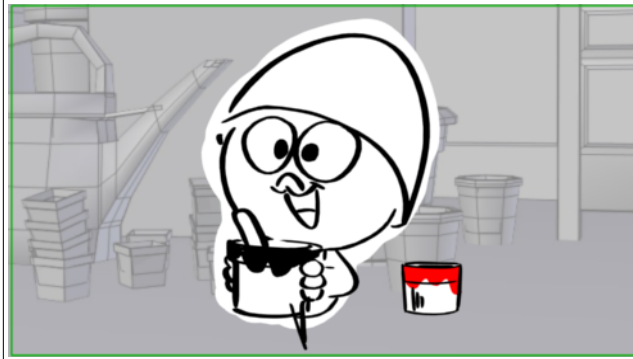

Dialogue

3. CALIMERO (se dirigeant vers un pot de peinture noire)
je te l'ai déjà dit !

Scene	Duration	Panel	Duration
004	03:19	6	00:14

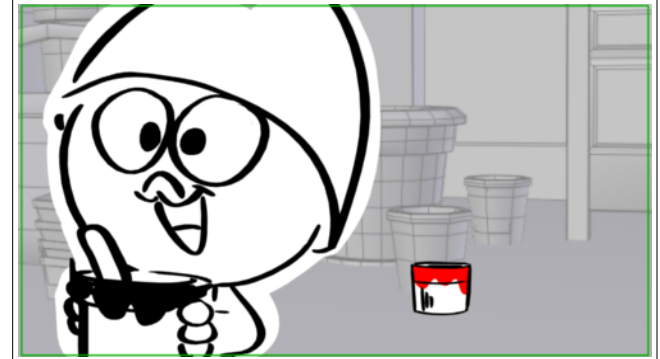

Dialogue

3. CALIMERO (se dirigeant vers un pot de peinture noire)
je te l'ai déjà dit !

Scene	Duration	Panel	Duration
005	07:04	1	00:09

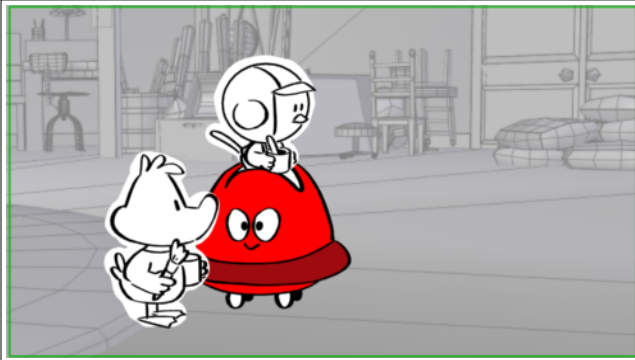

Dialogue
 3. CALIMERO
 C'est une surprise pour Priscilla,

Scene	Duration	Panel	Duration
005	07:04	2	01:17

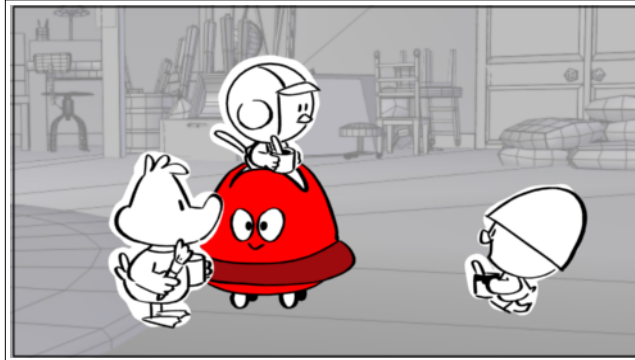

Dialogue
 3. CALIMERO
 C'est une surprise pour Priscilla,

Scene	Duration	Panel	Duration
005	07:04	3	01:14

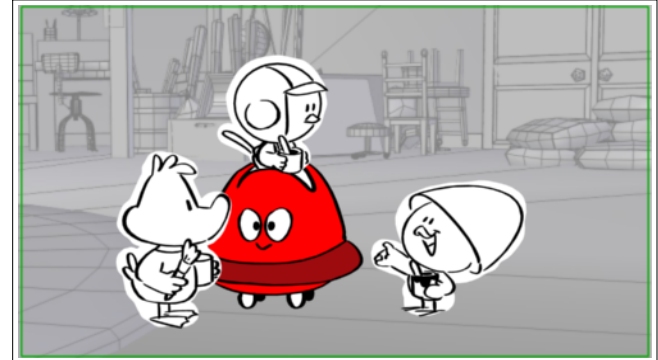

Dialogue
 3. CALIMERO
 on va lui faire une voiture rouge

Scene	Duration	Panel	Duration
005	07:04	4	01:14

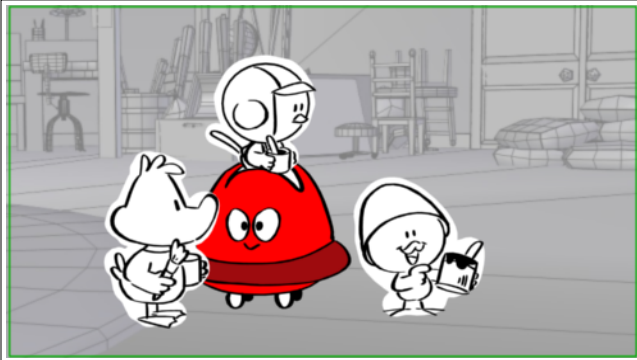

Dialogue

3. CALIMERO
avec des pois noirs,

Scene	Duration	Panel	Duration
005	07:04	5	00:06

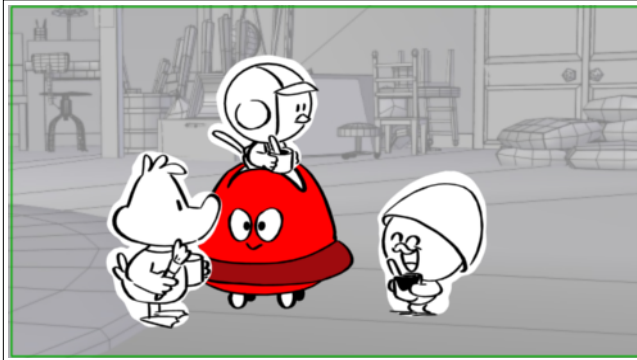

Dialogue

3. CALIMERO
comme une coccinelle !

Scene	Duration	Panel	Duration
005	07:04	6	00:06

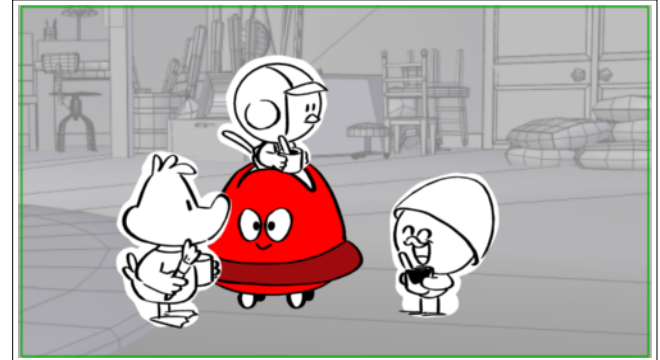

Dialogue

3. CALIMERO
comme une coccinelle !

Scene	Duration	Panel	Duration
005	07:04	7	00:06

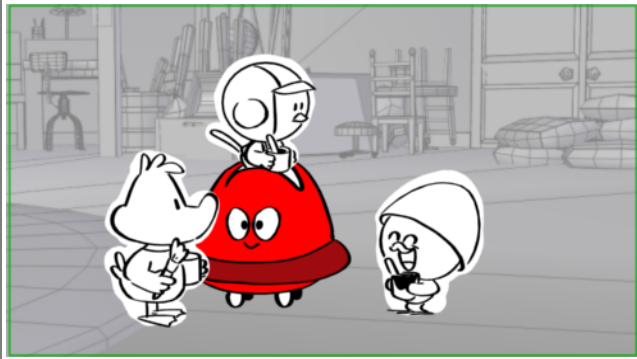

Dialogue

3. CALIMERO
comme une coccinelle !

Scene	Duration	Panel	Duration
005	07:04	8	00:07

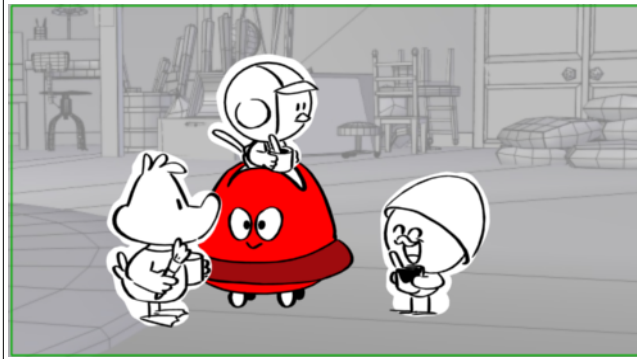

Dialogue

3. CALIMERO
comme une coccinelle !

Scene	Duration	Panel	Duration
005	07:04	9	01:00

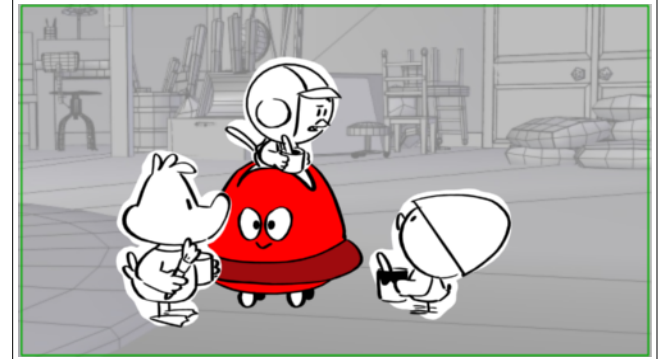

Dialogue

. VALERIANO (freinant l'enthousiasme de Caliméro)
Tu es sûr Caliméro ?

Scene	Duration	Panel	Duration
006	03:11	1	01:00



Dialogue

4. VALERIANO (freinant l'enthousiasme de Caliméro)

Tu es sûr Caliméro ?

Scene	Duration	Panel	Duration
006	03:11	2	01:00



Dialogue

4. VALERIANO (freinant l'enthousiasme de Caliméro)

Priscilla arrive bientôt !

Scene	Duration	Panel	Duration
006	03:11	3	01:11

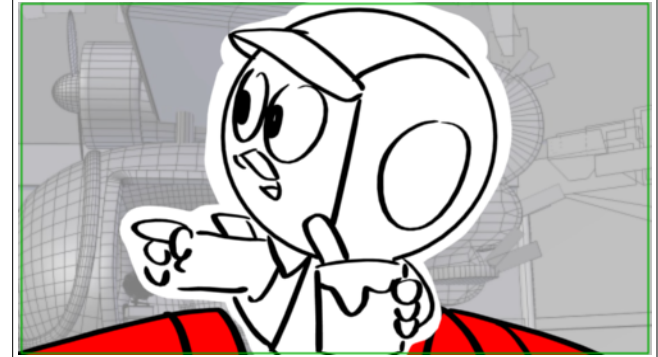

Dialogue

4. VALERIANO (freinant l'enthousiasme de Caliméro)

On en a encore trois autres à peindre !

Scene	Duration	Panel	Duration
007	02:09	1	02:09

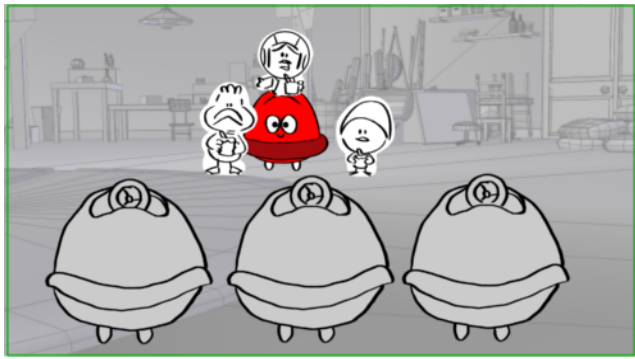

Dialogue
 4. VALERIANO (freinant l'enthousiasme de Caliméro)
 On n'aura jamais le temps de tout finir,

Scene	Duration	Panel	Duration
008	07:00	1	00:13



Scene	Duration	Panel	Duration
008	07:00	2	00:06



Scene	Duration	Panel	Duration
008	07:00	3	00:12



Scene	Duration	Panel	Duration
008	07:00	4	01:09



Dialogue
 5. CALIMERO
 Mais si, regardez !

Scene	Duration	Panel	Duration
008	07:00	5	00:14



Dialogue
 5. CALIMERO
 C'est facile !

Scene	Duration	Panel	Duration
008	07:00	6	00:11



Dialogue
 5. CALIMERO
 Comme ça,

Scene	Duration	Panel	Duration
008	07:00	7	00:09



Dialogue
 5. CALIMERO
 Comme ça,

Scene	Duration	Panel	Duration
008	07:00	8	00:11



Dialogue
 5. CALIMERO
 Comme ça,

Scene	Duration	Panel	Duration
008	07:00	9	00:20

Scene	Duration	Panel	Duration
008	07:00	10	00:04

Scene	Duration	Panel	Duration
008	07:00	11	00:16



Dialogue
 5. CALIMERO
 là.

Scene	Duration	Panel	Duration
008	07:00	12	01:00

Scene	Duration	Panel	Duration
009	02:04	1	02:04



Dialogue

PICK UP
Oups!

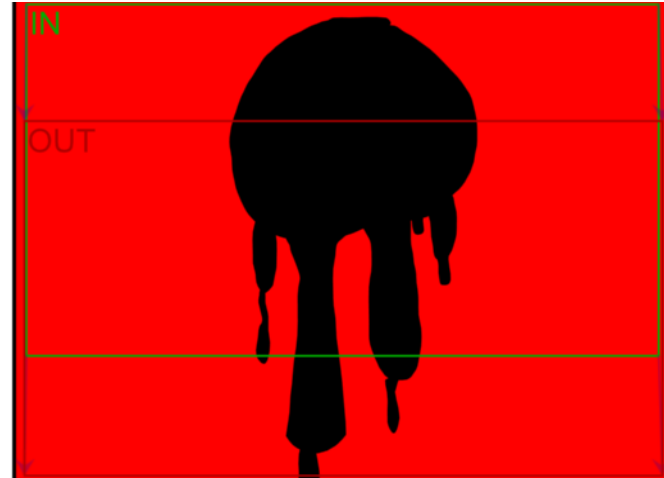

Dialogue

PICK UP CALIMERO
Oh non!

Scene	Duration	Panel	Duration
010	08:01	1	00:10

**Dialogue**

6. PIERROT (brut de décoffrage)
Il est tout moisi du bec, ton pois !

Scene	Duration	Panel	Duration
010	08:01	2	00:11

**Dialogue**

6. PIERROT (brut de décoffrage)
Il est tout moisi du bec, ton pois !

Scene	Duration	Panel	Duration
010	08:01	3	01:12

**Dialogue**

6. PIERROT (brut de décoffrage)
Il est tout moisi du bec, ton pois !

Scene	Duration	Panel	Duration
010	08:01	4	02:14



Dialogue

7. CALIMERO (déçu, le regard fixé sur sa tache) MODIF
 Euh? C'est vrai que c'est pas si facile que ça en fait!

Scene	Duration	Panel	Duration
010	08:01	5	02:04



Dialogue

7. CALIMERO (déçu, le regard fixé sur sa tache) MODIF
 Euh? C'est vrai que c'est pas si facile que ça en fait!

Scene	Duration	Panel	Duration
010	08:01	6	01:00

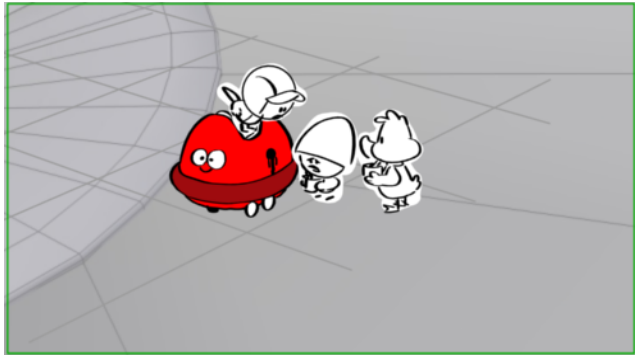

Scene	Duration	Panel	Duration
011	05:12	1	00:14

**Dialogue**

7. CALIMERO (déçu, le regard fixé sur sa tache) MODIF
Ohhh!?

Scene	Duration	Panel	Duration
011	05:12	2	00:13

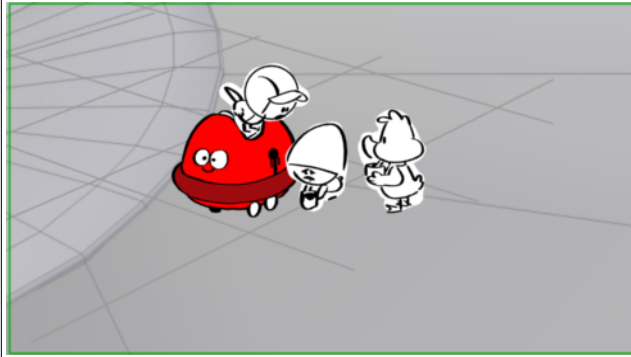
**Dialogue**

7. CALIMERO (déçu, le regard fixé sur sa tache) MODIF
Ohhh!?

Scene	Duration	Panel	Duration
011	05:12	3	01:09

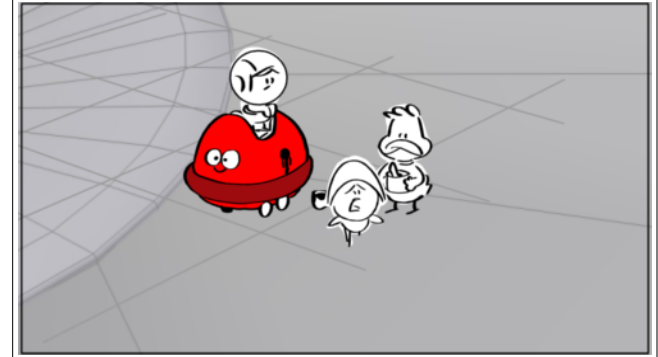
**Dialogue**

7. CALIMERO (déçu, le regard fixé sur sa tache) MODIF
Comment on va faire?

Scene	Duration	Panel	Duration
011	05:12	4	03:01

Scene	Duration	Panel	Duration
012	03:07	1	00:08

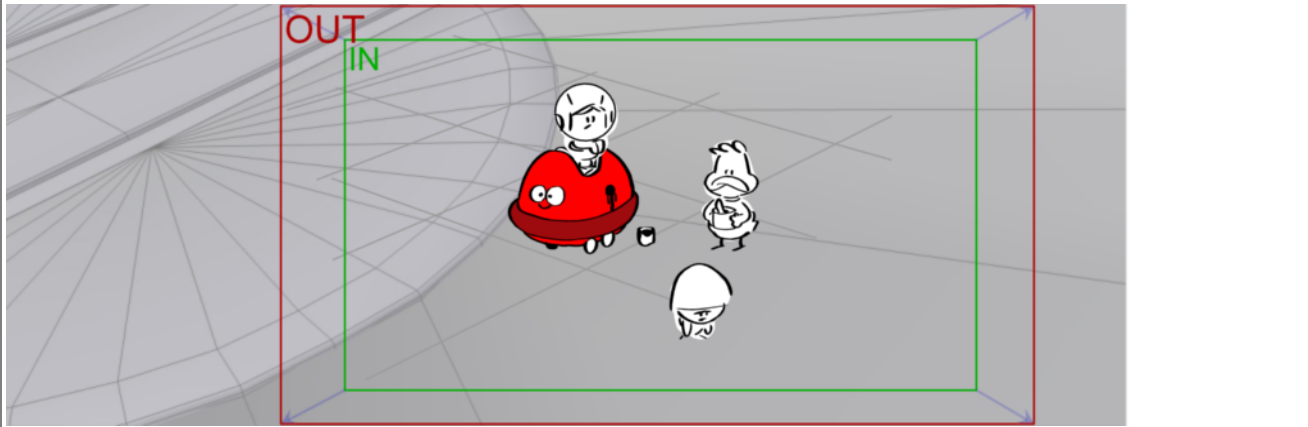

Dialogue
 PICK UP CALIMERO
 C'est la catastrophe!

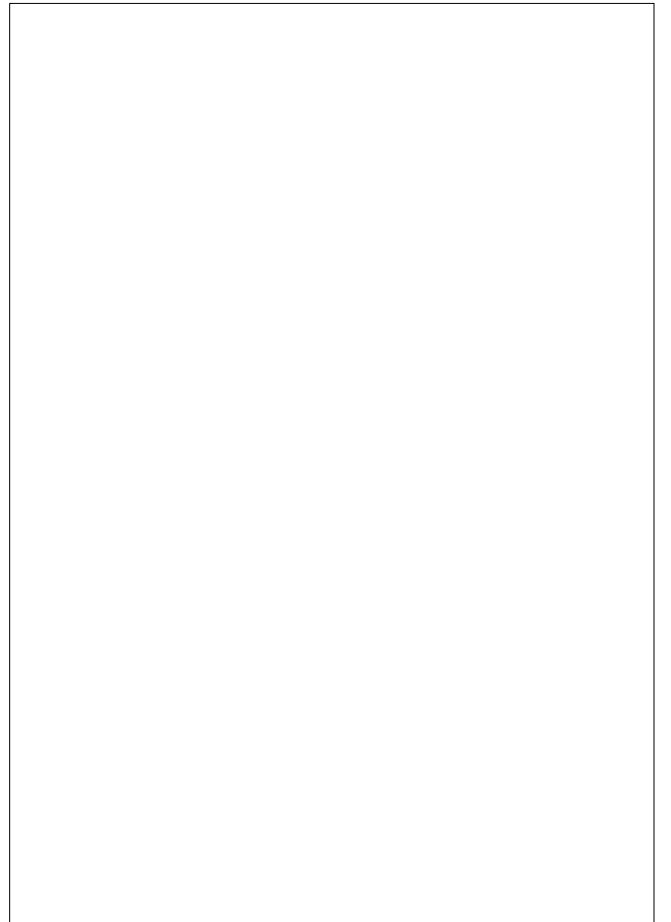

Scene	Duration	Panel	Duration
012	03:07	2	00:04

Scene	Duration	Panel	Duration
012	03:07	3	00:13

Scene	Duration	Panel	Duration
012	03:07	4	01:00



Dialogue

PICK UP VALERIANO

Hum....

Scene	Duration	Panel	Duration
012	03:07	5	00:09

Scene	Duration	Panel	Duration
012	03:07	6	00:23

Scene	Duration	Panel	Duration
013	05:15	1	00:07

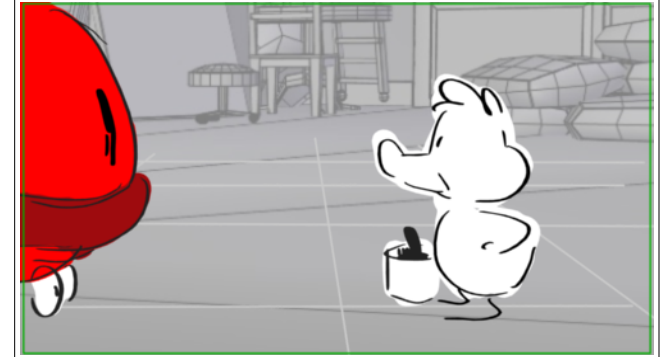
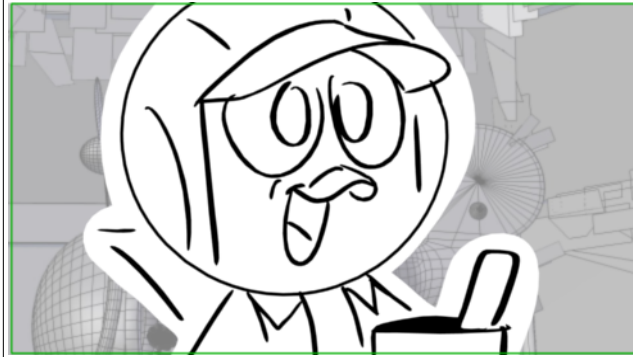

Dialogue

PICK UP VALERIANO
Je sais!

Scene	Duration	Panel	Duration
013	05:15	2	00:13

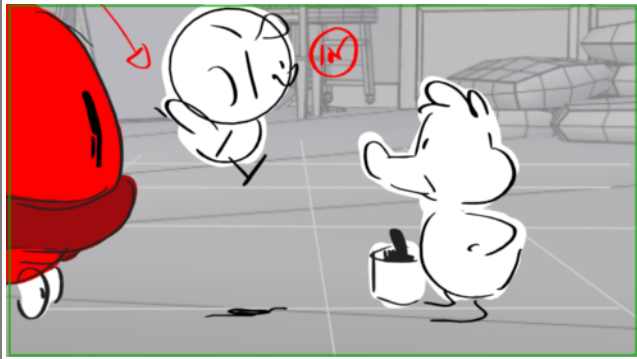

Dialogue
 8. VALERIANO (fulgurant)
 Et si on utilisait une machine

Scene	Duration	Panel	Duration
013	05:15	3	00:10

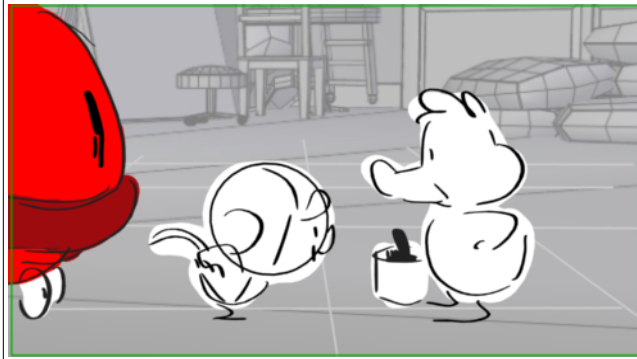

Dialogue
 8. VALERIANO (fulgurant)
 Et si on utilisait une machine

Scene	Duration	Panel	Duration
013	05:15	4	02:03

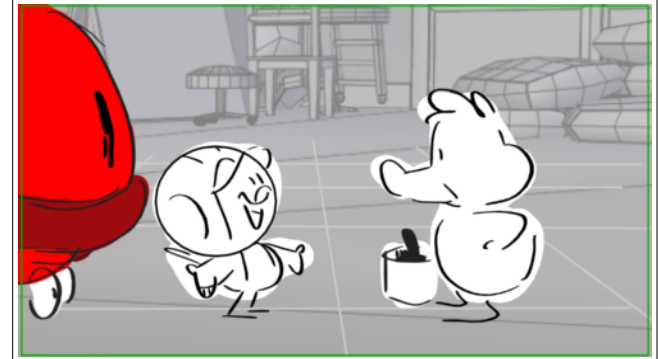

Dialogue
 8. VALERIANO (fulgurant)
 de Do Vinci ?

Scene	Duration	Panel	Duration
013	05:15	5	00:08

Scene	Duration	Panel	Duration
013	05:15	6	00:06

Scene	Duration	Panel	Duration
013	05:15	7	00:06

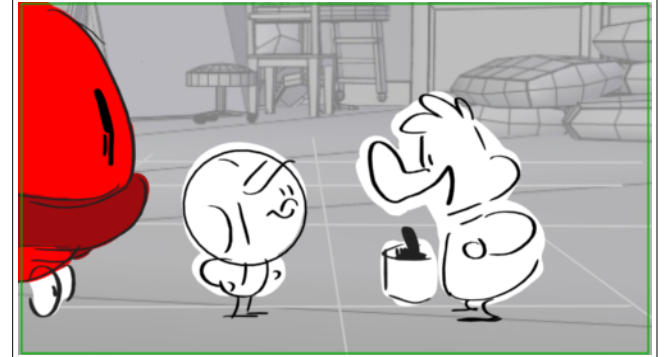
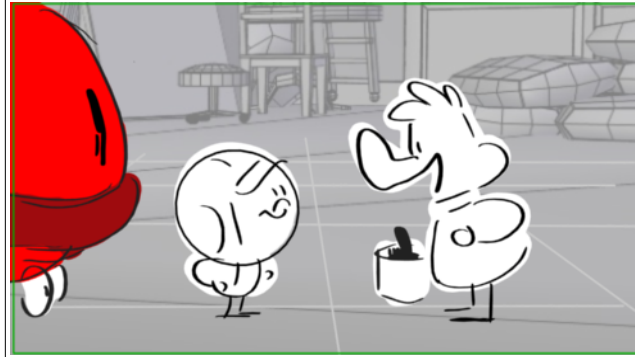
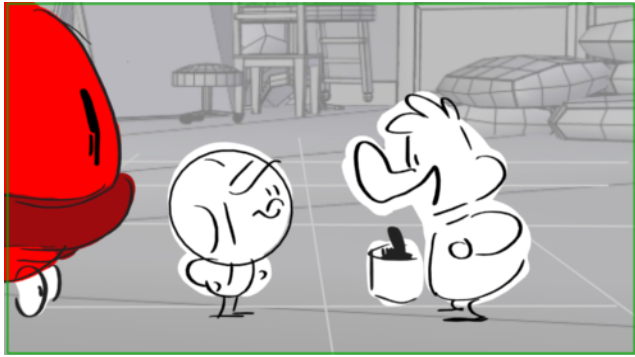

Dialogue

9. PIERROT (excité par la proposition)
Ce serait carrément géniali génialo !

Dialogue

9. PIERROT (excité par la proposition)
Ce serait carrément géniali génialo !

Dialogue

9. PIERROT (excité par la proposition)
Ce serait carrément géniali génialo !

Scene	Duration	Panel	Duration
013	05:15	8	00:06

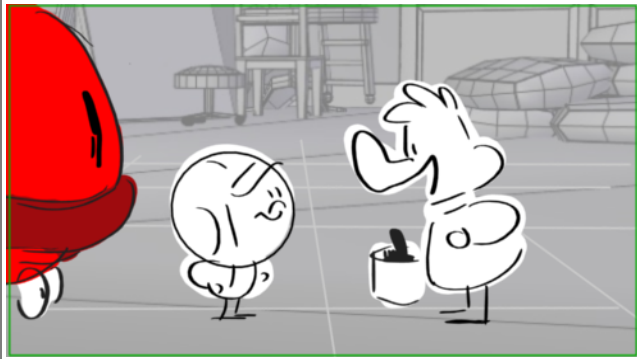

Dialogue

9. PIERROT (excité par la proposition)
Ce serait carrément géniali génialo !

Scene	Duration	Panel	Duration
013	05:15	9	00:06

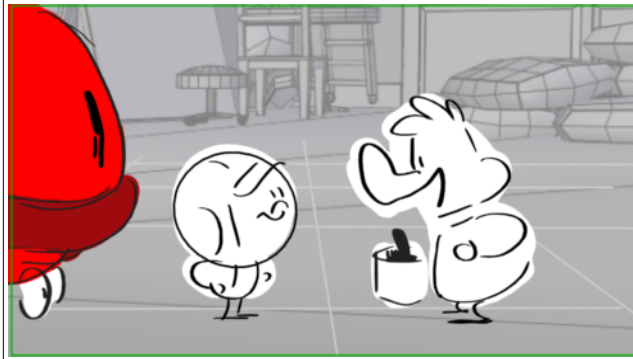

Dialogue

9. PIERROT (excité par la proposition)
Ce serait carrément géniali génialo !

Scene	Duration	Panel	Duration
013	05:15	10	01:00

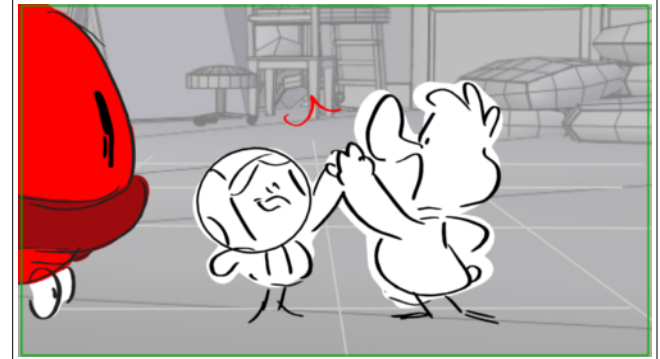



Scene	Duration	Panel	Duration
014	03:12	1	00:06

Scene	Duration	Panel	Duration
014	03:12	2	00:05

Scene	Duration	Panel	Duration
014	03:12	3	00:07

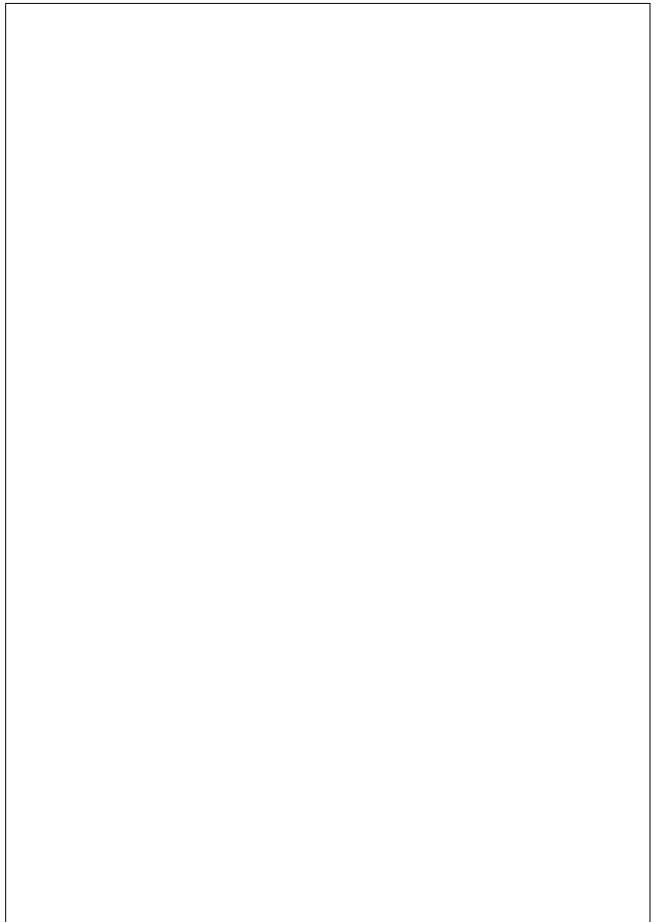
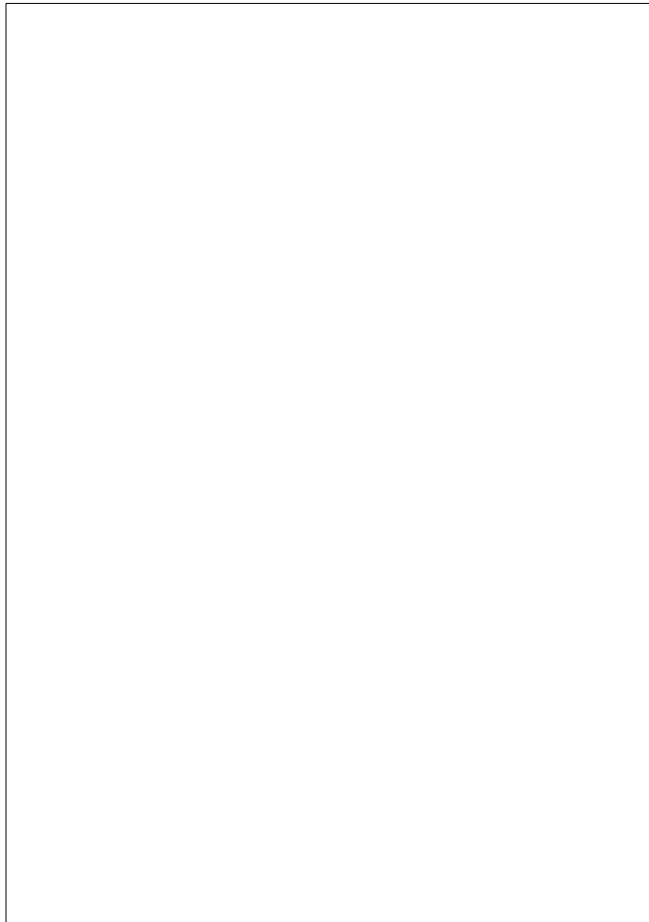

Scene	Duration	Panel	Duration
014	03:12	4	00:13



Dialogue
 10. CALIMERO (partant)
 Oui !

Scene	Duration	Panel	Duration
014	03:12	5	02:06



Dialogue
 10. CALIMERO (partant)
 C'est une trop grande idée Valériano !

Scene	Duration	Panel	Duration
015	05:15	1	02:21

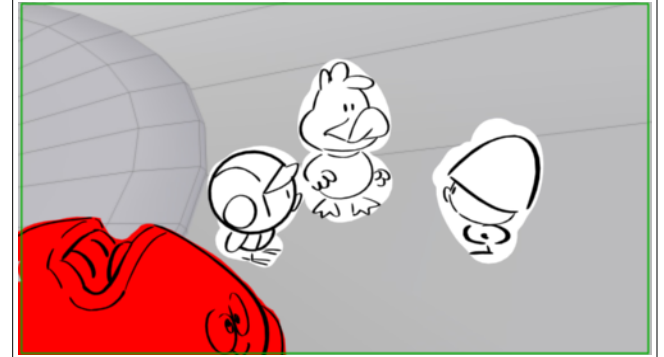

Dialogue
 10. CALIMERO (partant)
 Do Vinci a sûrement inventé la machine
 qu'il nous faut !



Scene	Duration	Panel	Duration
015	05:15	2	00:20

Scene	Duration	Panel	Duration
015	05:15	3	00:19

Scene	Duration	Panel	Duration
015	05:15	4	00:18

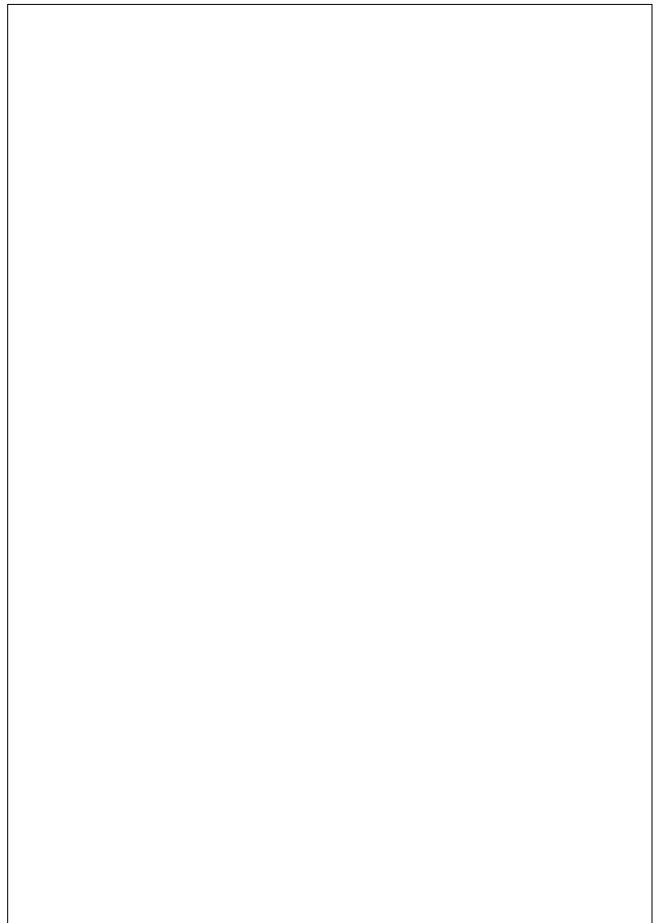
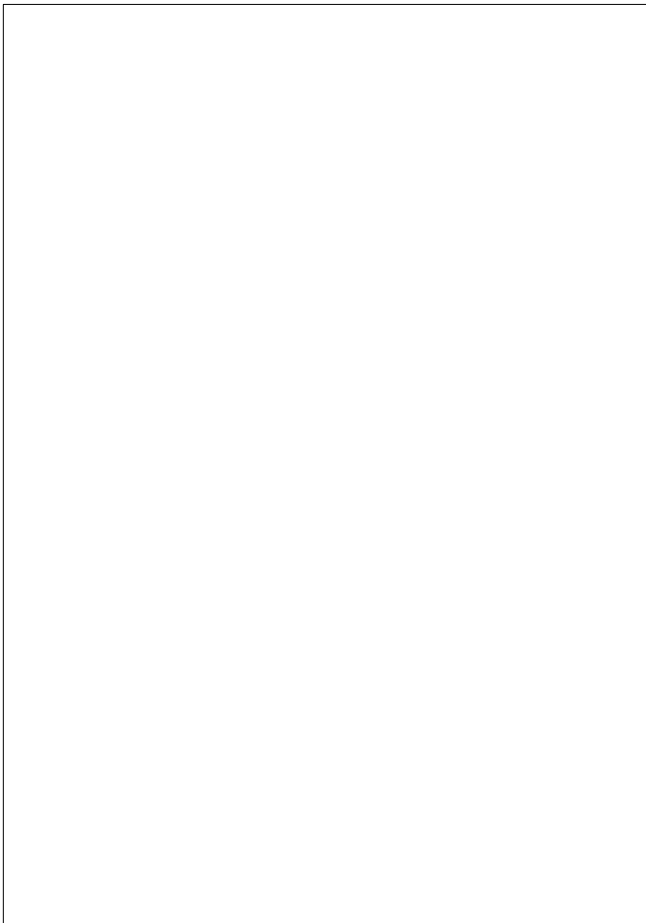
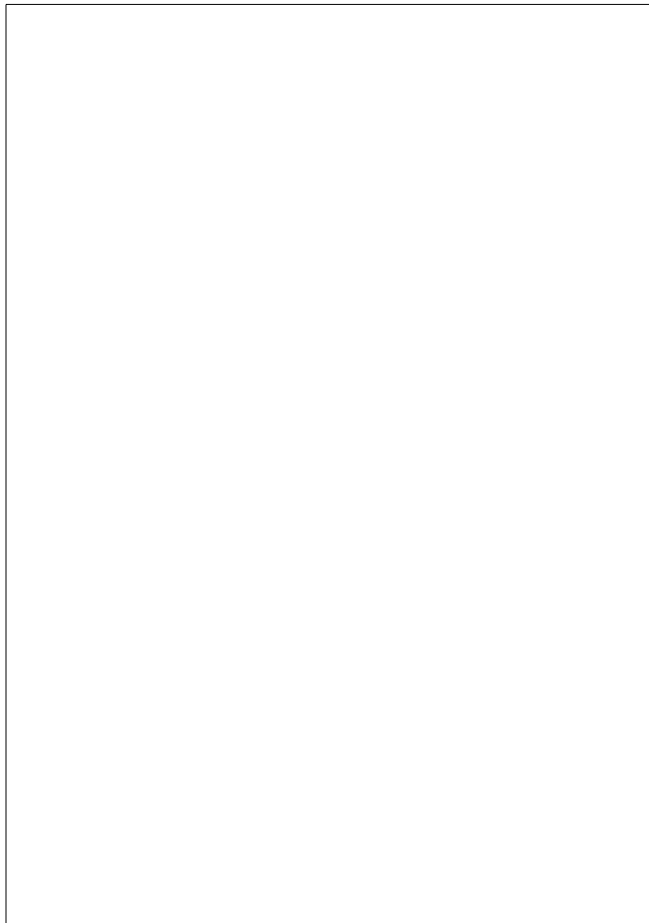
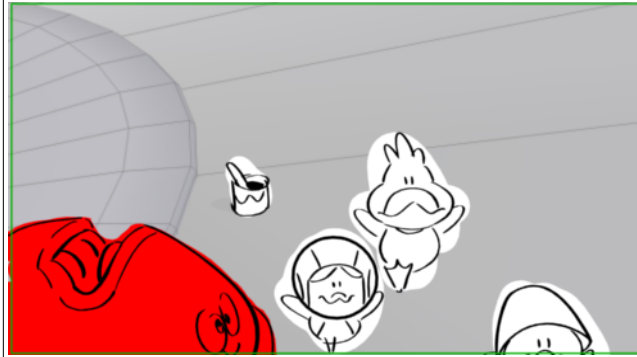

Scene	Duration	Panel	Duration
015	05:15	5	00:12

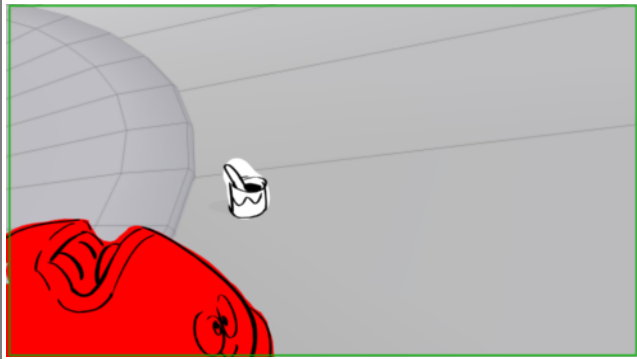

Scene	Duration	Panel	Duration
016	03:15	1	01:24

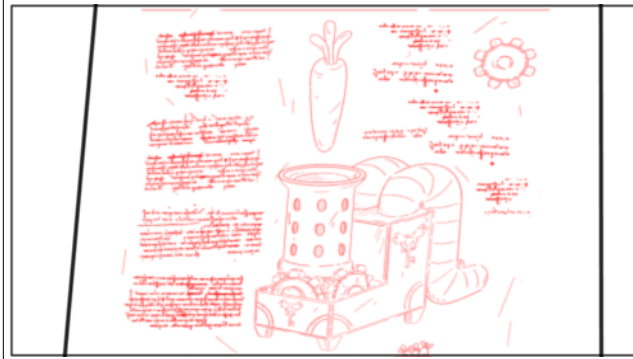

Dialogue
 11. CALIMERO (concentré, tournant les pages)
 Alors, carottes-éplucheur à soupape,

Action Notes
 POV CALIMERO
 pages du grimoire des inventions

Scene	Duration	Panel	Duration
016	03:15	2	00:16

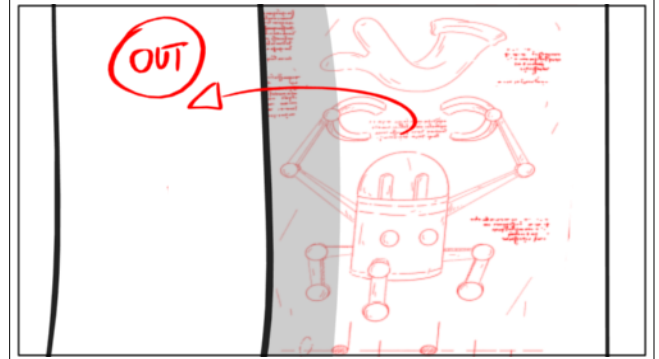

Scene	Duration	Panel	Duration
016	03:15	3	01:00

Scene	Duration	Panel	Duration
017	15:12	1	00:23

Scene	Duration	Panel	Duration
017	15:12	2	00:18

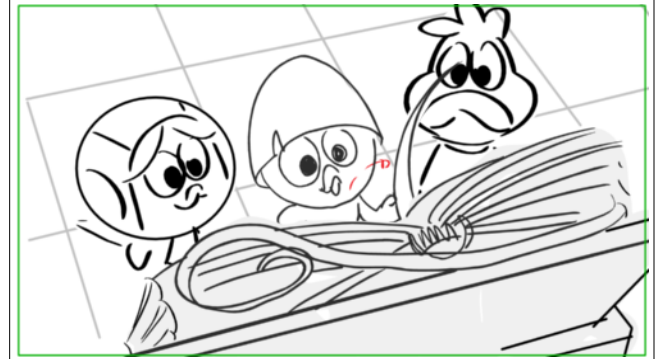
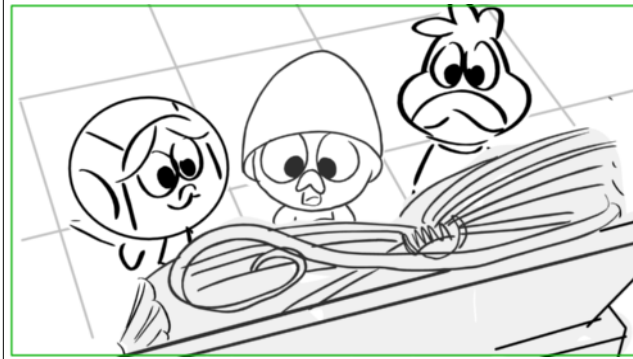
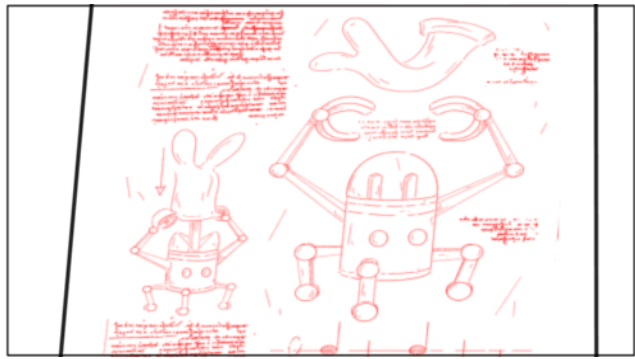

Dialogue
 11. CALIMERO (concentré, tournant les pages)
 chaussettes auto-nettoyantes?

Scene	Duration	Panel	Duration
017	15:12	3	00:18

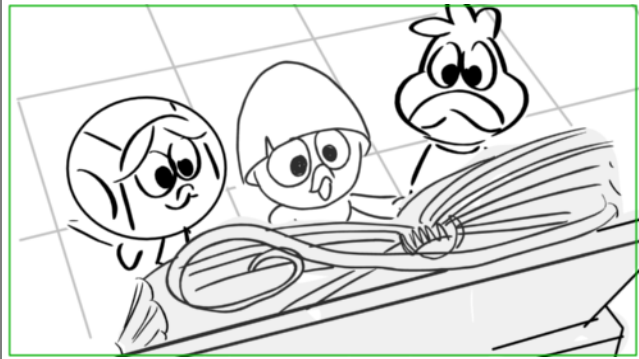

Scene	Duration	Panel	Duration
017	15:12	4	00:18

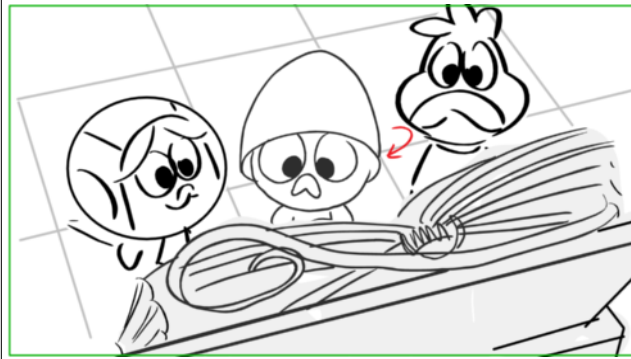

Scene	Duration	Panel	Duration
017	15:12	5	06:00

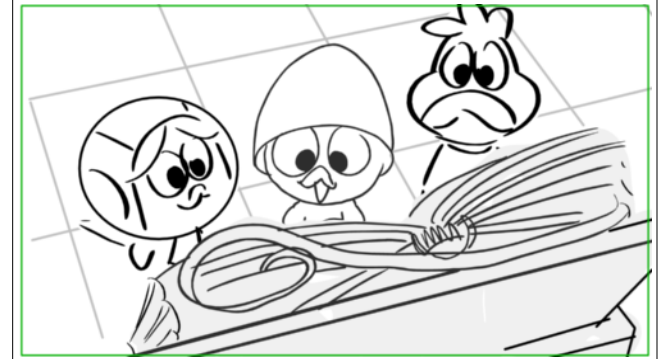

Dialogue

11. CALIMERO

Voilà! Le COLORIMOITOUT !

12. CALIMERO

Lampe qui colorie tout grâce à un rayon de lumière !

Scene	Duration	Panel	Duration
017	15:12	6	03:18

Scene	Duration	Panel	Duration
017	15:12	7	02:17

NO PANEL

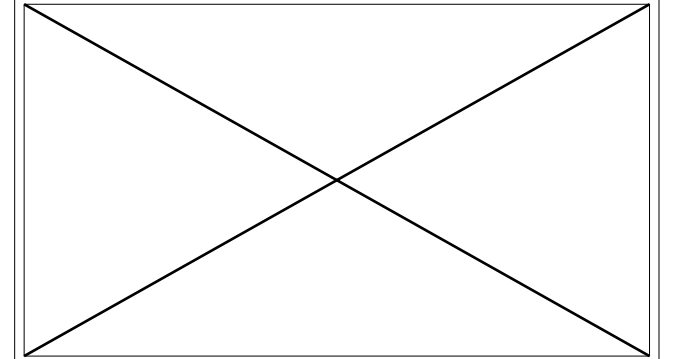
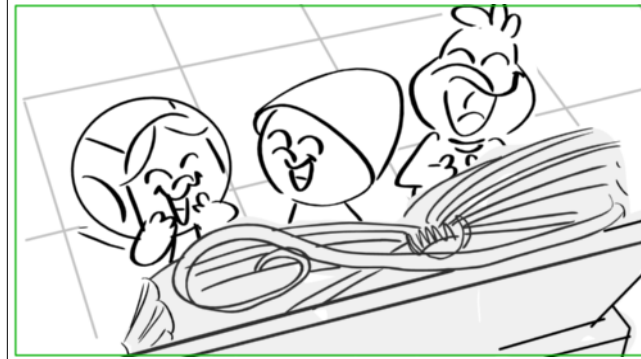
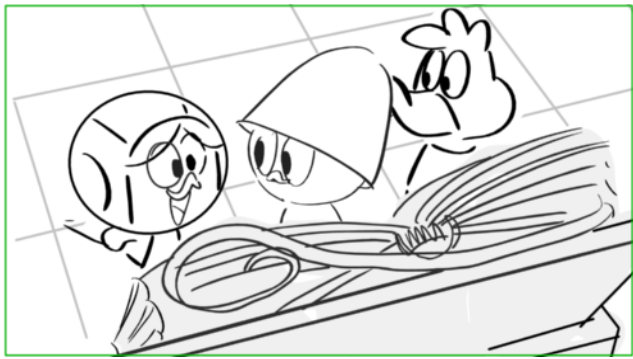

Dialogue
 13. VALERIANO (exalté, « quittant la lecture »)
 Eh! Tu crois que Do Vinci s'en servait pour avoir un pyjama différent tous les soirs !

Dialogue
 PICK UP
 Ha! ha! ha!

Scene	Duration	Panel	Duration
018	03:02	1	03:02

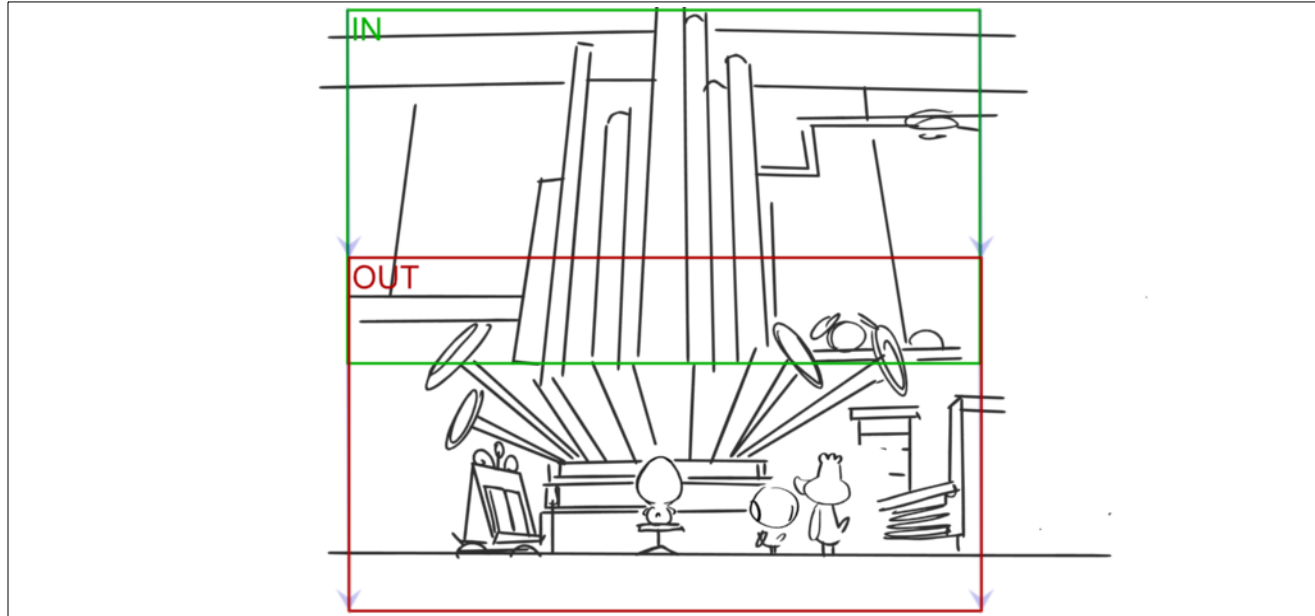

Action Notes
 Caliméro est face à l'orgue,

Scene	Duration	Panel	Duration
019	00:22	1	00:11

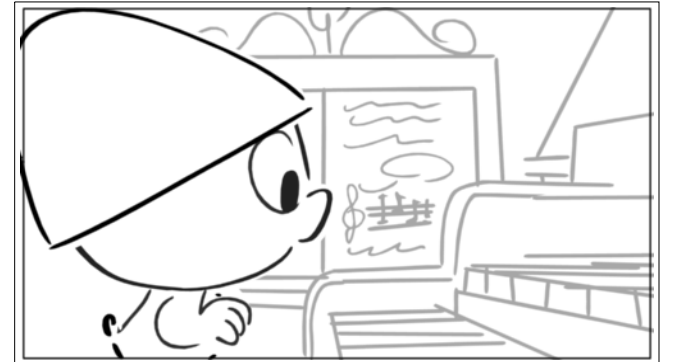

Action Notes
 il joue des NOTES DE MUSIQUE.

Scene	Duration	Panel	Duration
019	00:22	2	00:11



Scene	Duration	Panel	Duration
020	01:10	1	00:10

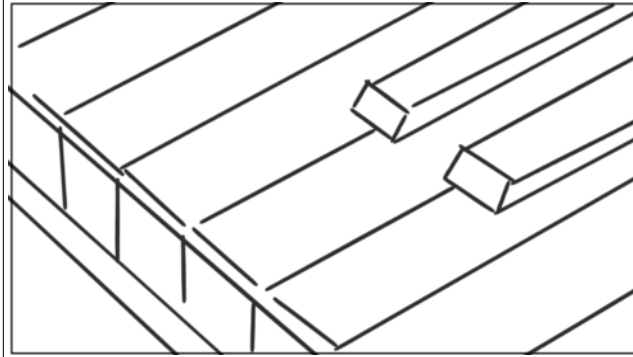

Action Notes
close up piano

Scene	Duration	Panel	Duration
020	01:10	2	01:00

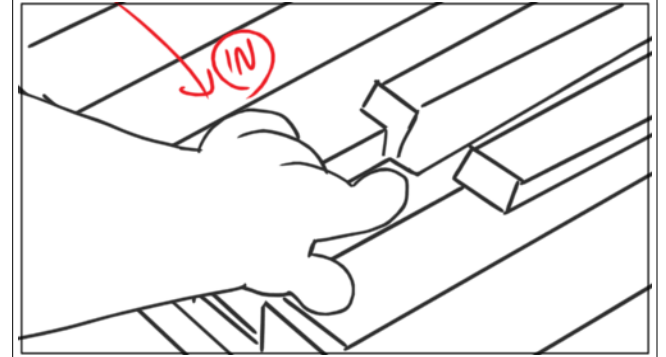

Action Notes
play

Scene	Duration	Panel	Duration
021	01:12	1	01:12

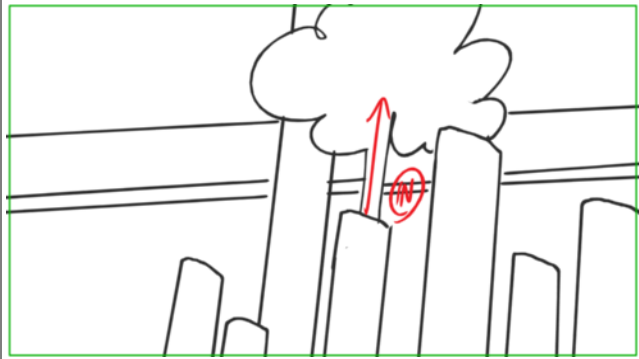

Action Notes
 smoke out
 sounds playing

Scene	Duration	Panel	Duration
022	03:09	1	03:09

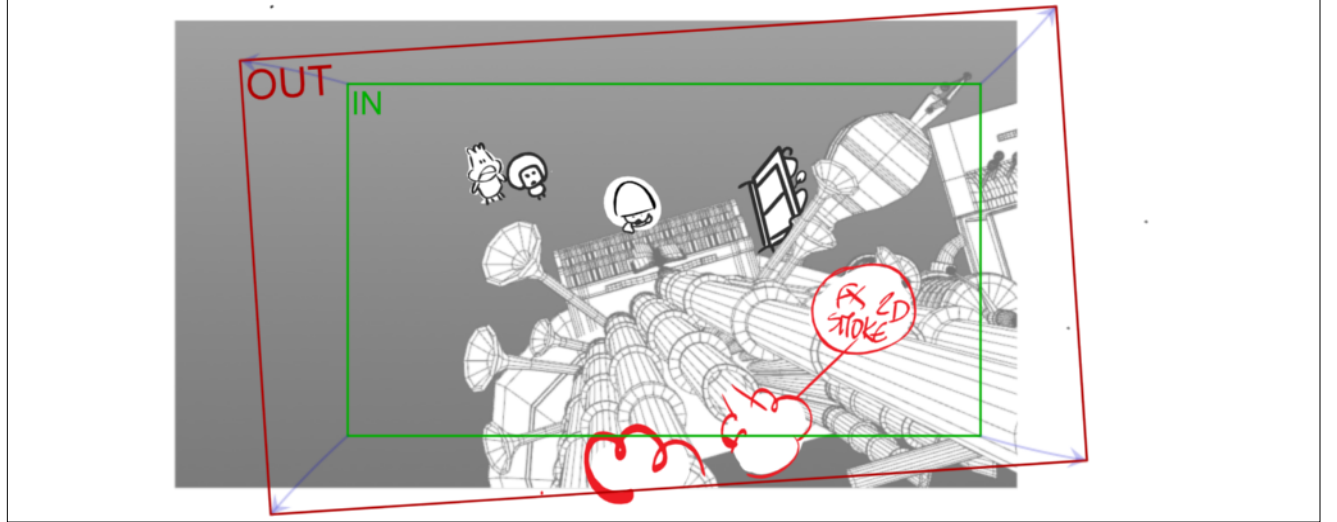

Action Notes
 constant pan as he is playing beautiful music



Scene	Duration	Panel	Duration
023	01:18	1	00:08

Scene	Duration	Panel	Duration
023	01:18	2	01:10

Scene	Duration	Panel	Duration
024	04:00	1	00:17

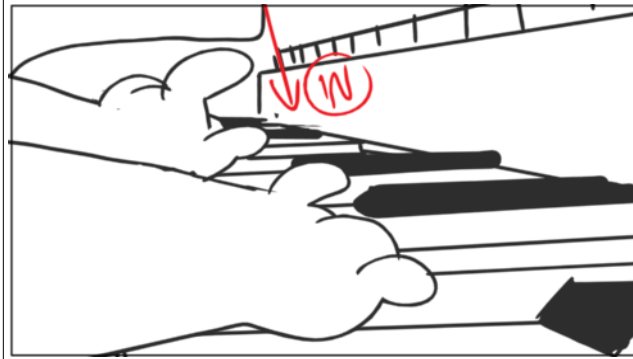
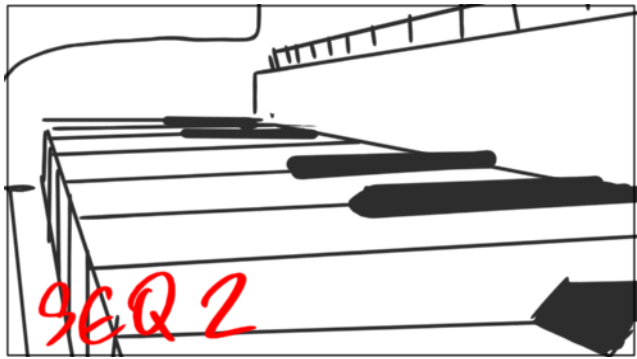

Action Notes

play with both hand at same time
hold it

Action Notes

constant truck out
inventions door



Scene	Duration	Panel	Duration
024	04:00	2	00:17

NO PANEL

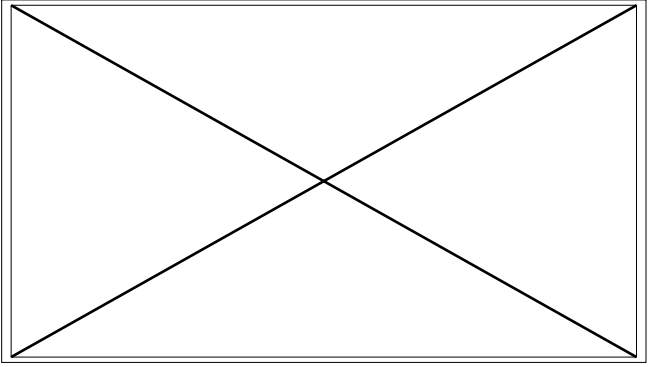
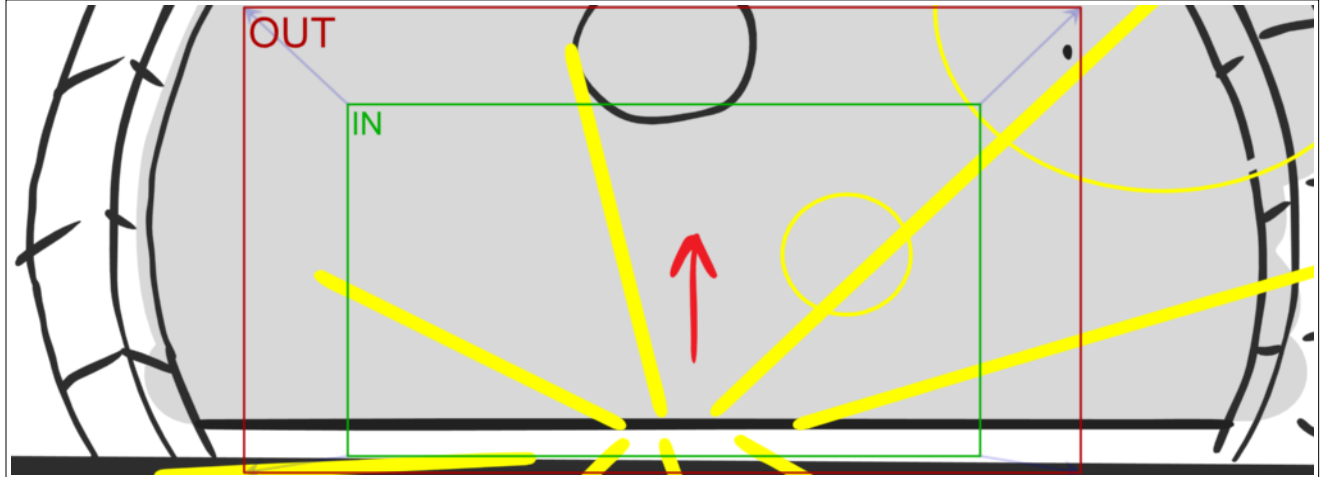

Action Notes
door open
light from it

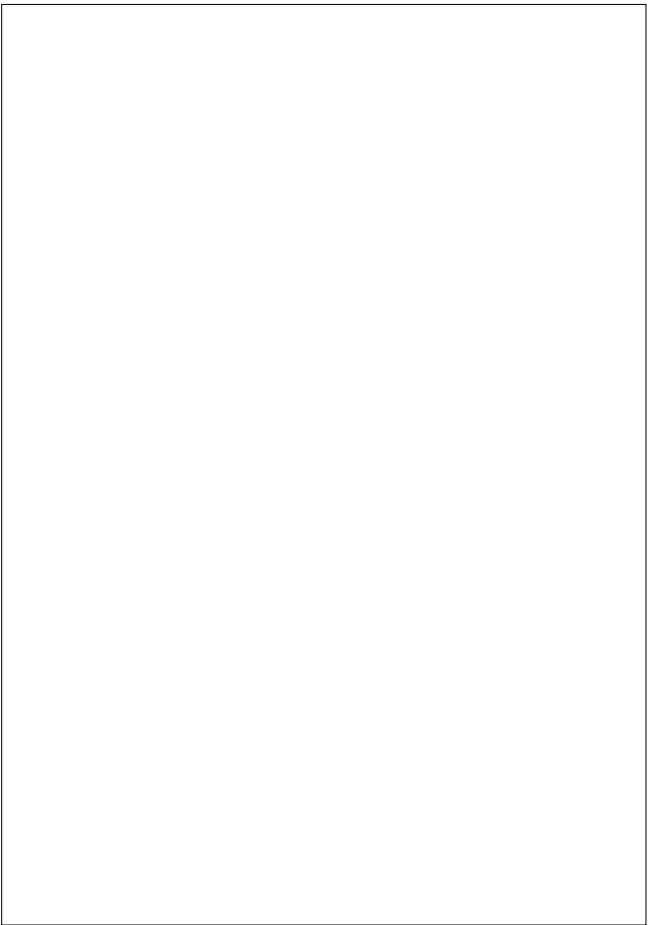



Scene	Duration	Panel	Duration
024	04:00	3	00:22

NO PANEL

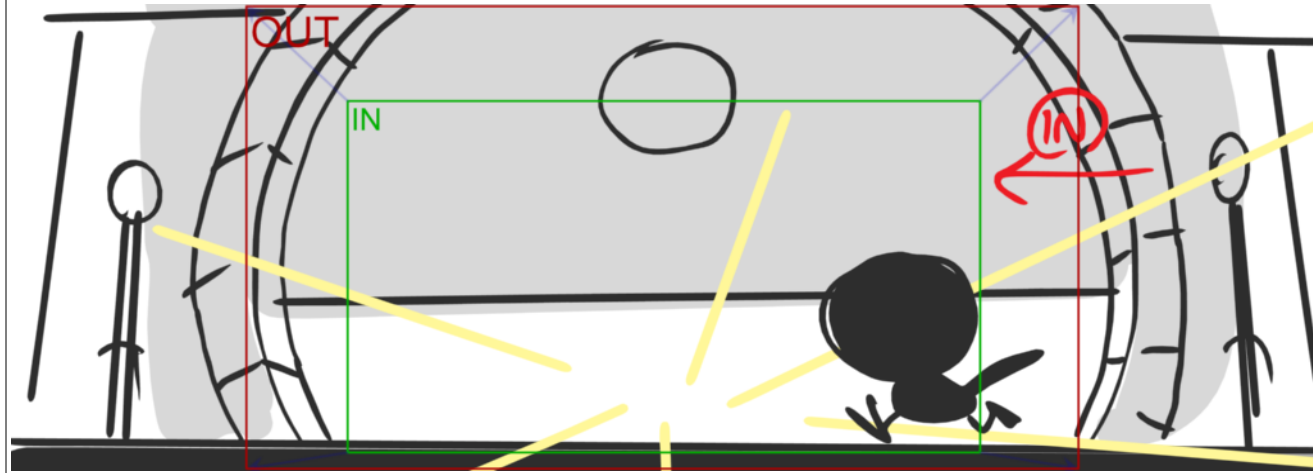

Action Notes

kids run in front of door

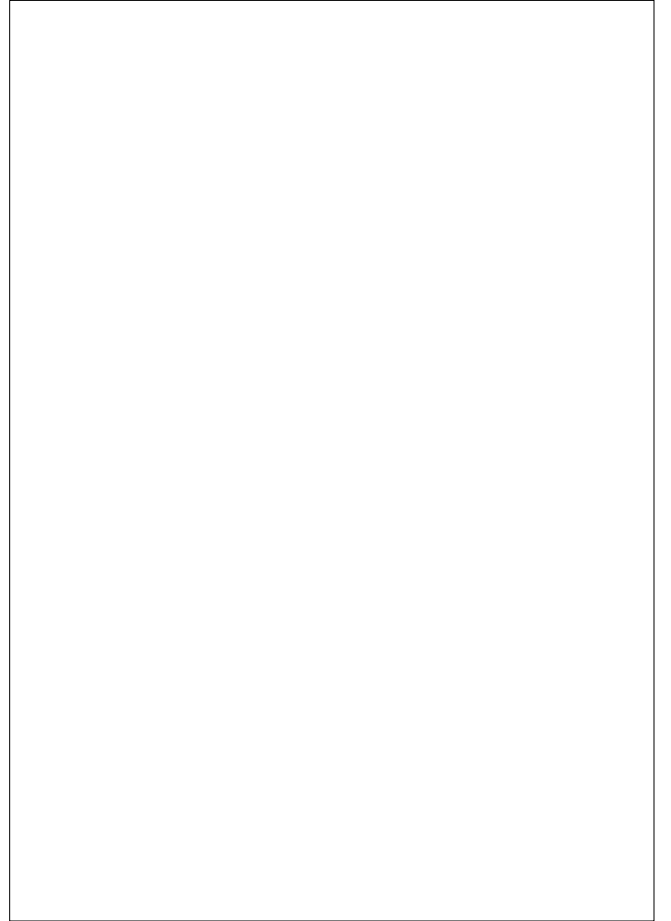
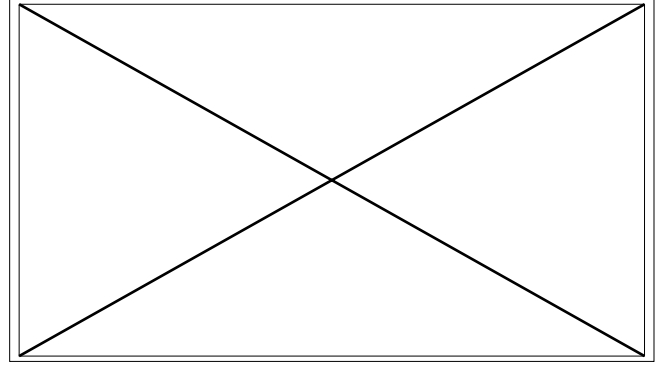



Scene	Duration	Panel	Duration
024	04:00	4	00:19

NO PANEL

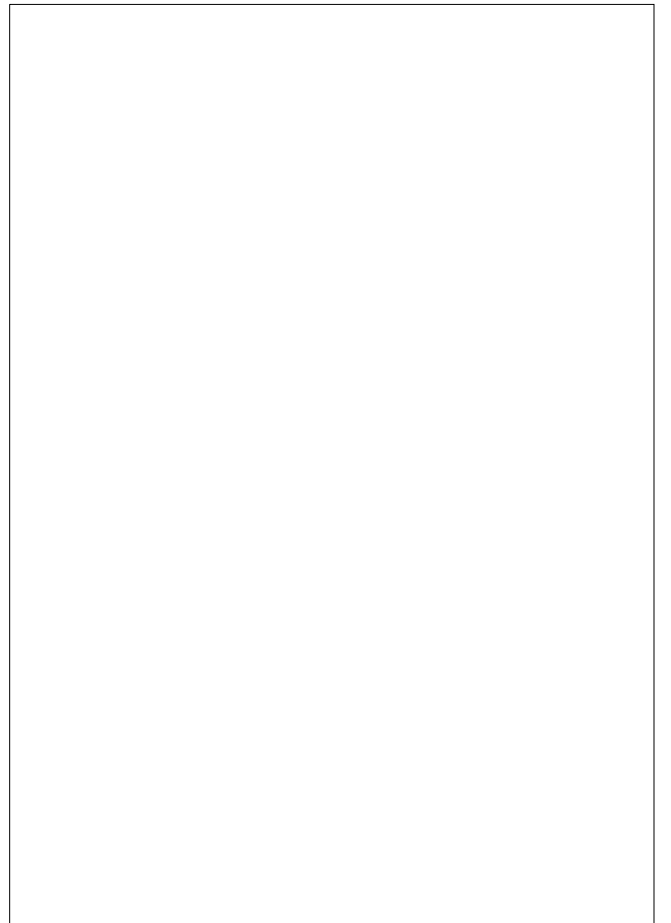
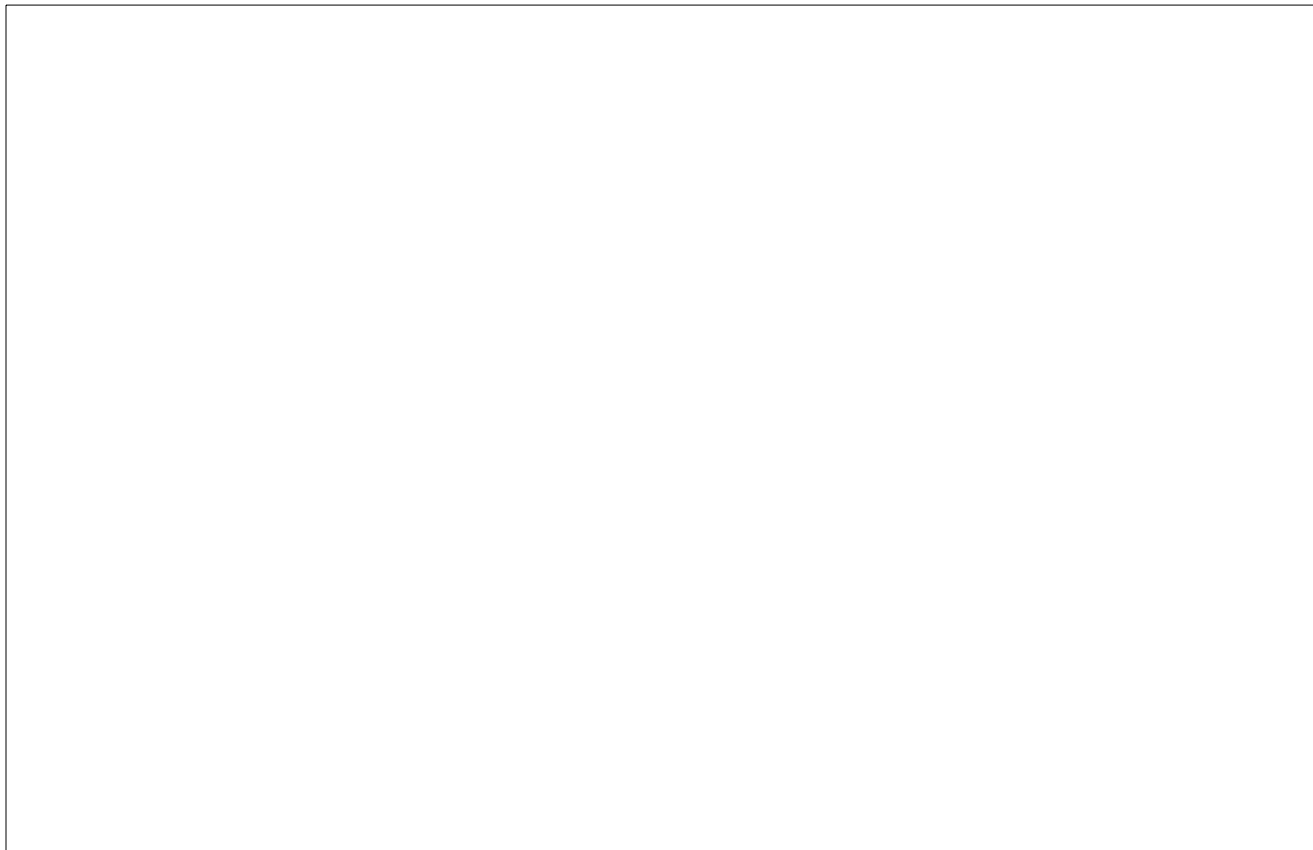
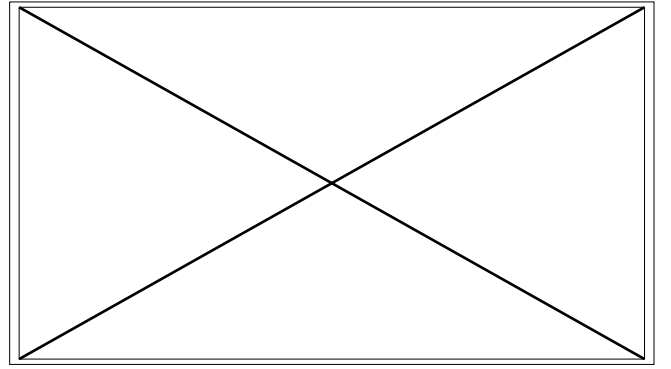
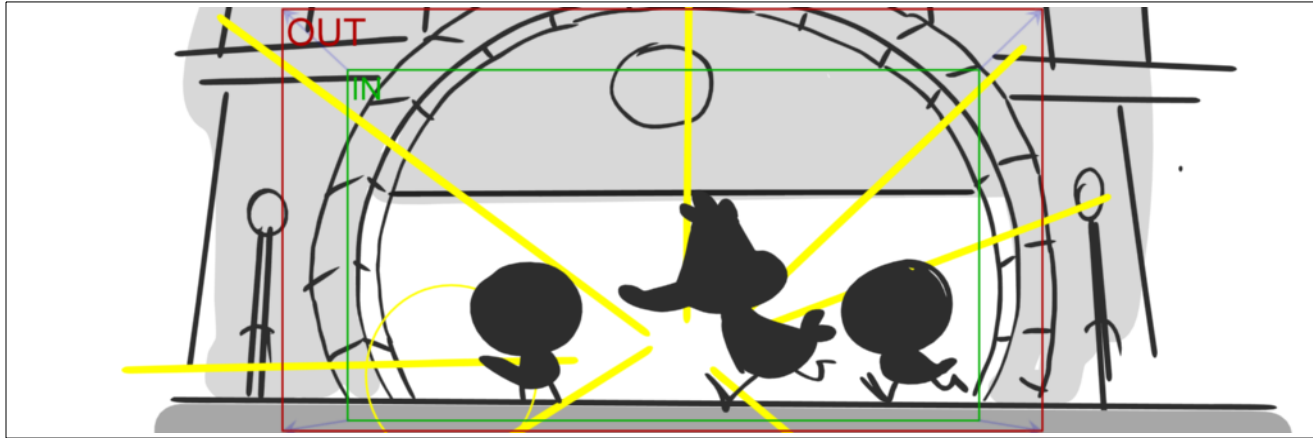

Scene	Duration	Panel	Duration
024	04:00	5	01:00

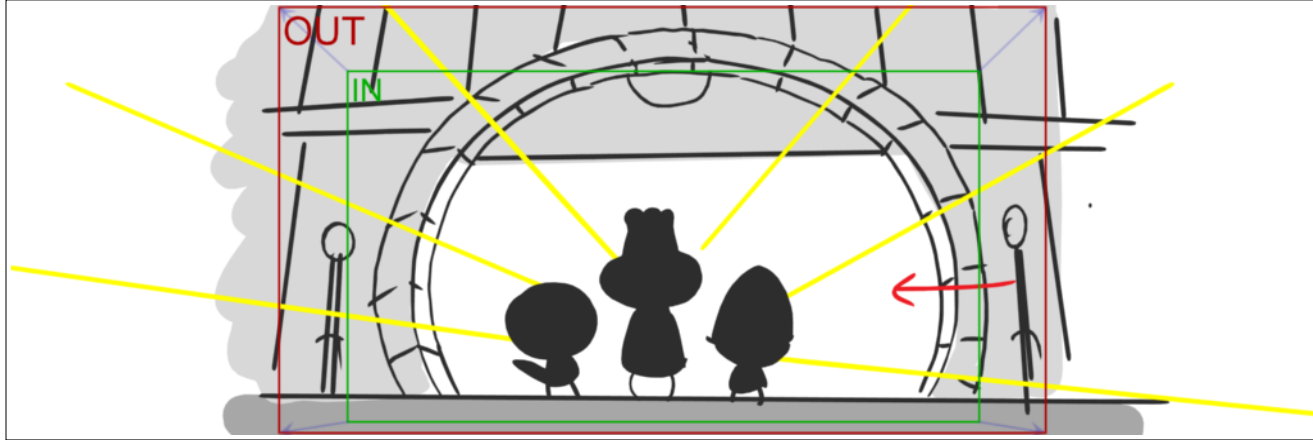

Scene	Duration	Panel	Duration
025	03:01	1	00:13

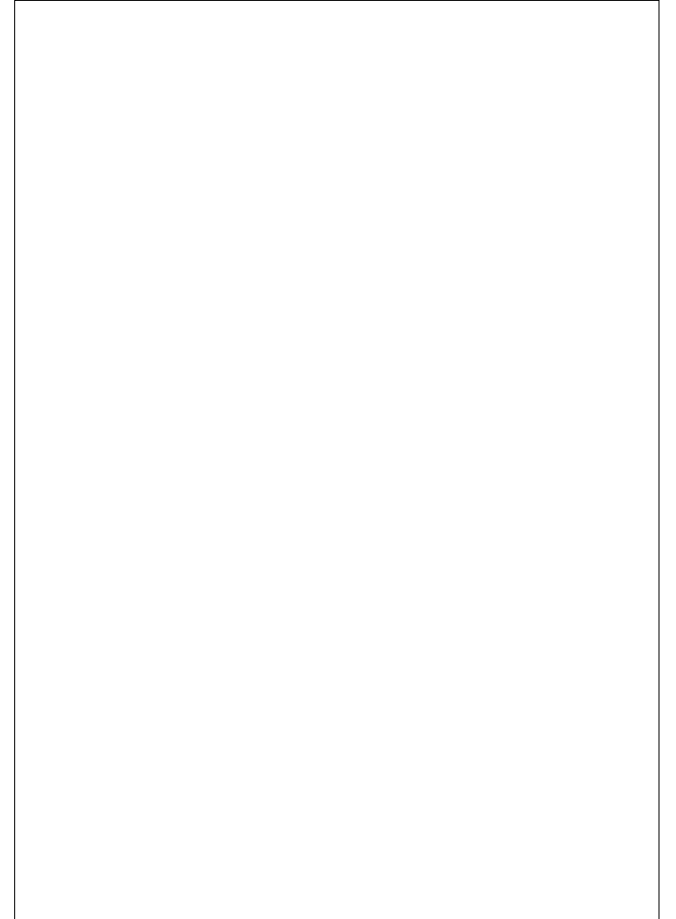
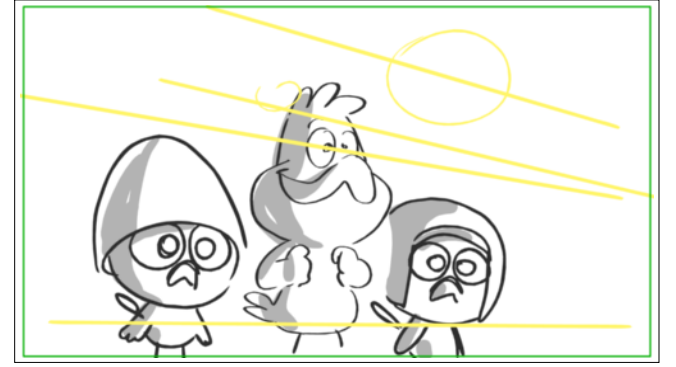



Scene	Duration	Panel	Duration
025	03:01	2	00:08

Scene	Duration	Panel	Duration
025	03:01	3	00:09

Scene	Duration	Panel	Duration
025	03:01	4	00:08

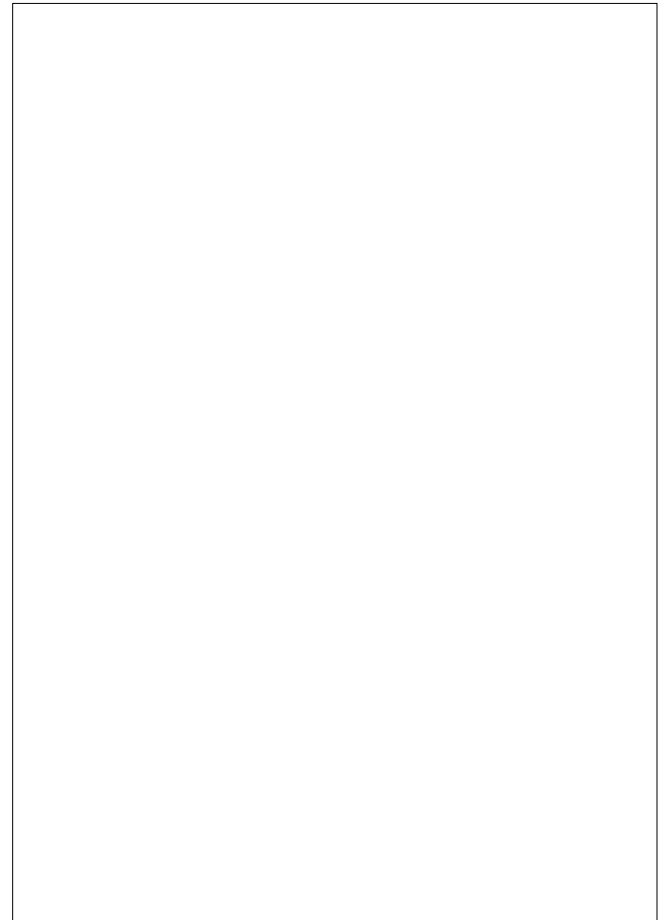
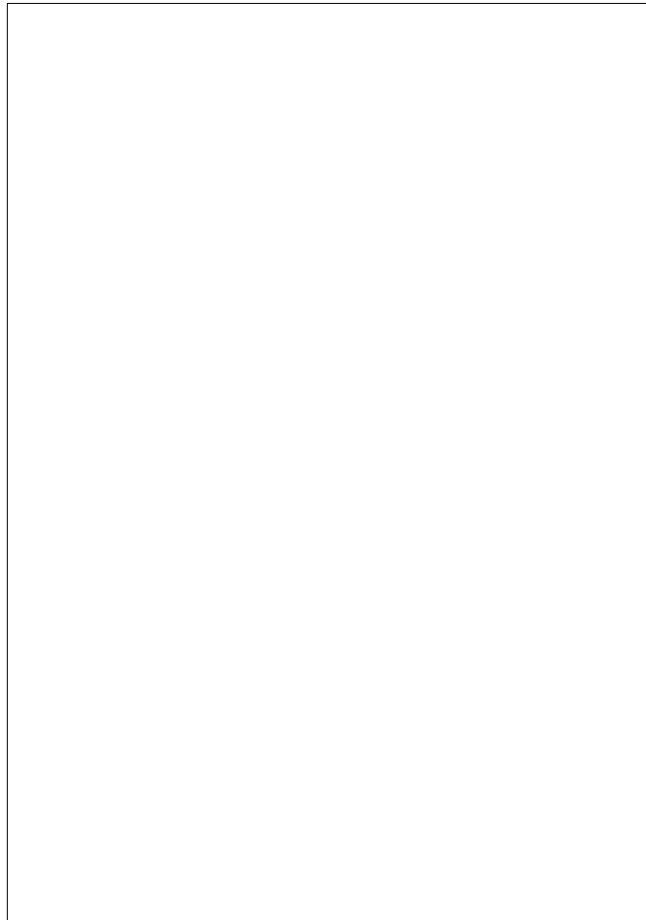
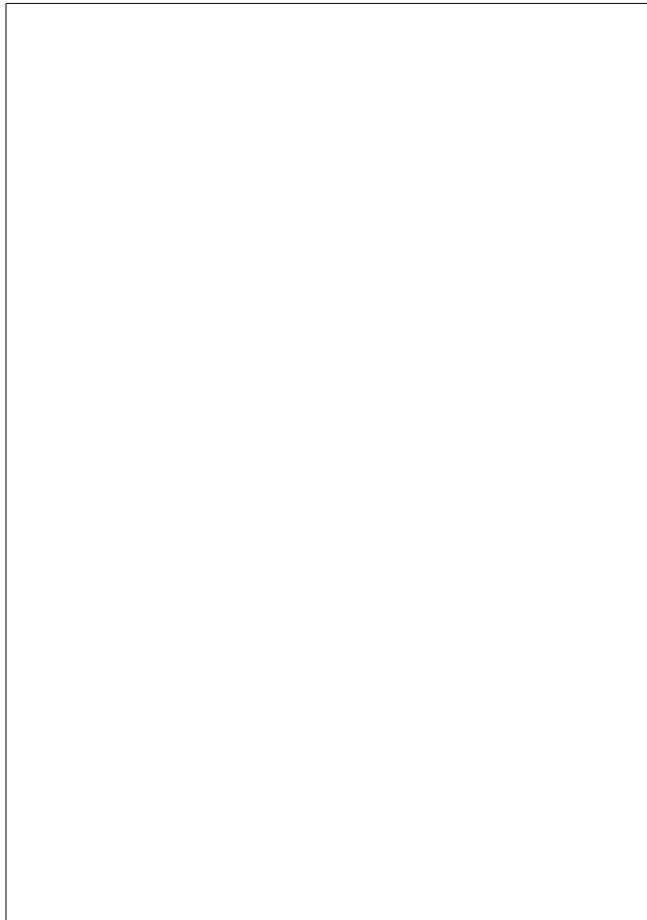
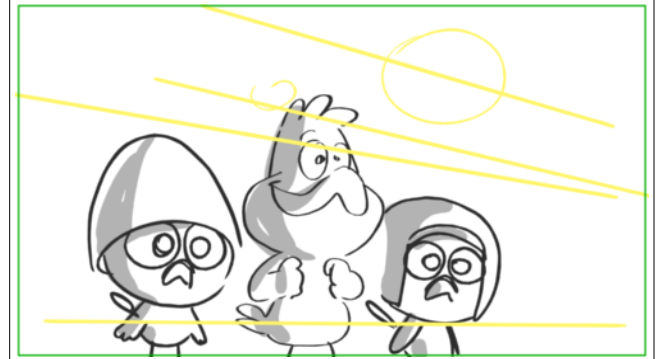
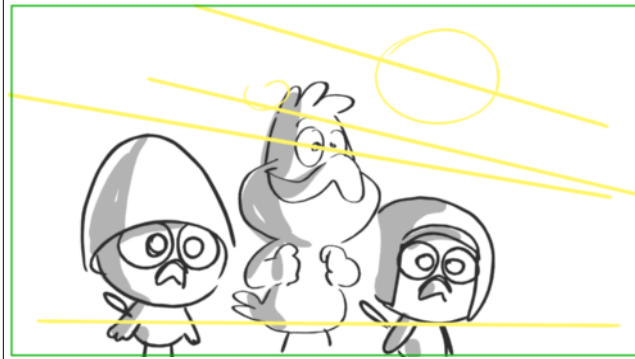
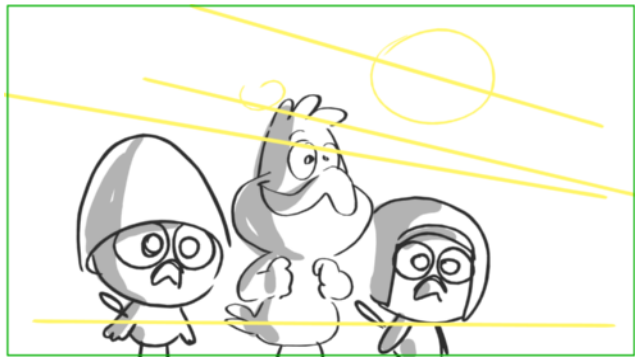

Scene	Duration	Panel	Duration
025	03:01	5	01:13

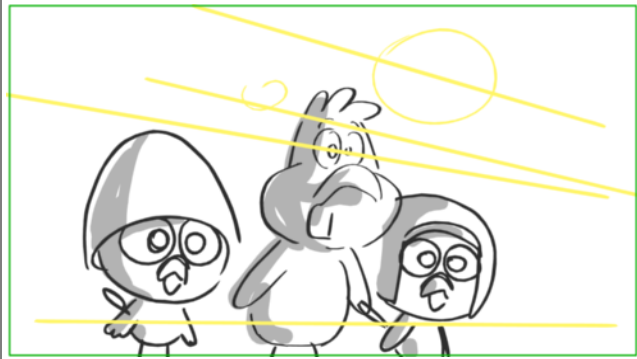

Dialogue

PICK UP
Ooohhh!

Scene	Duration	Panel	Duration
026	05:02	1	00:09

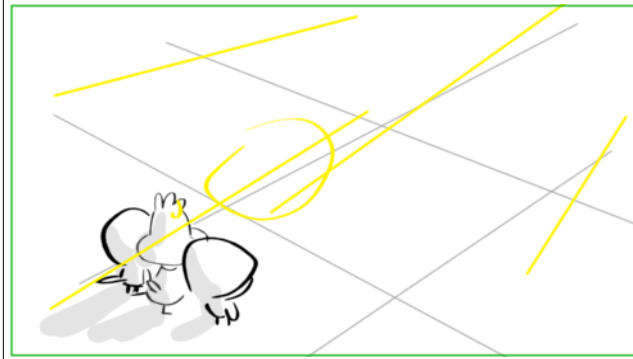

Scene	Duration	Panel	Duration
026	05:02	2	02:15

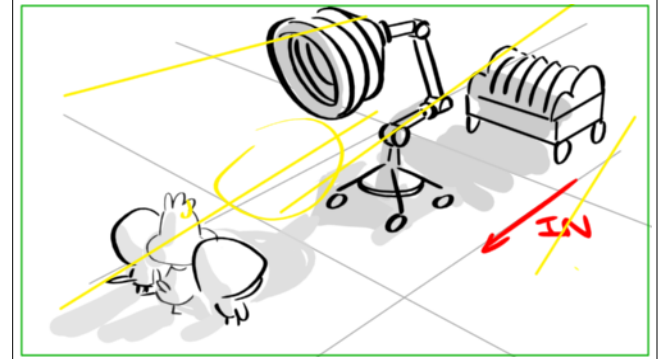

Action Notes

une grande lampe montée sur roulettes s'avance, une boîte de filtres à côté : c'est le Colorimoitout.

Scene	Duration	Panel	Duration
026	05:02	3	01:03

Scene	Duration	Panel	Duration
026	05:02	4	00:13

Scene	Duration	Panel	Duration
026	05:02	5	00:12

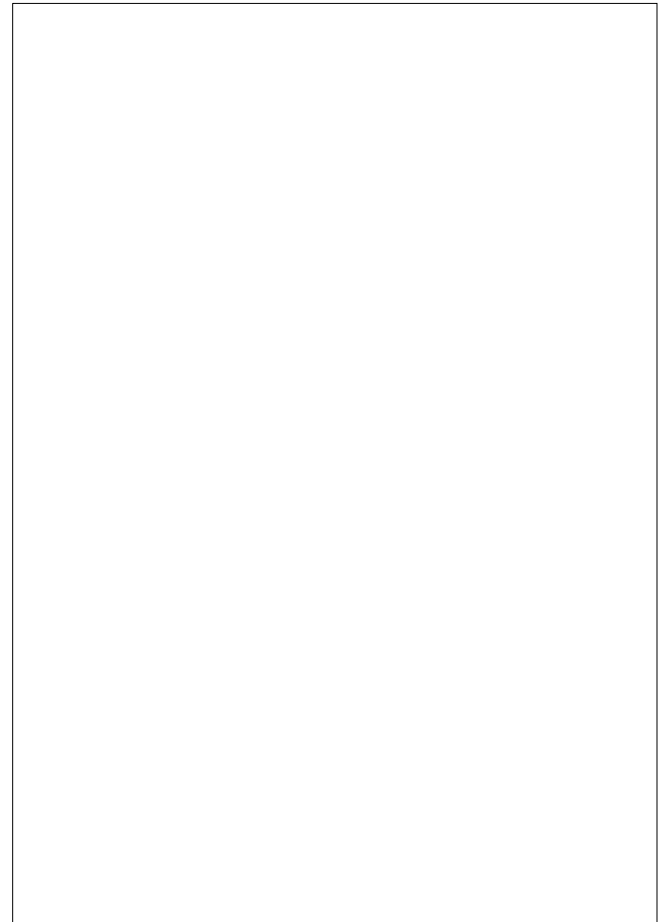
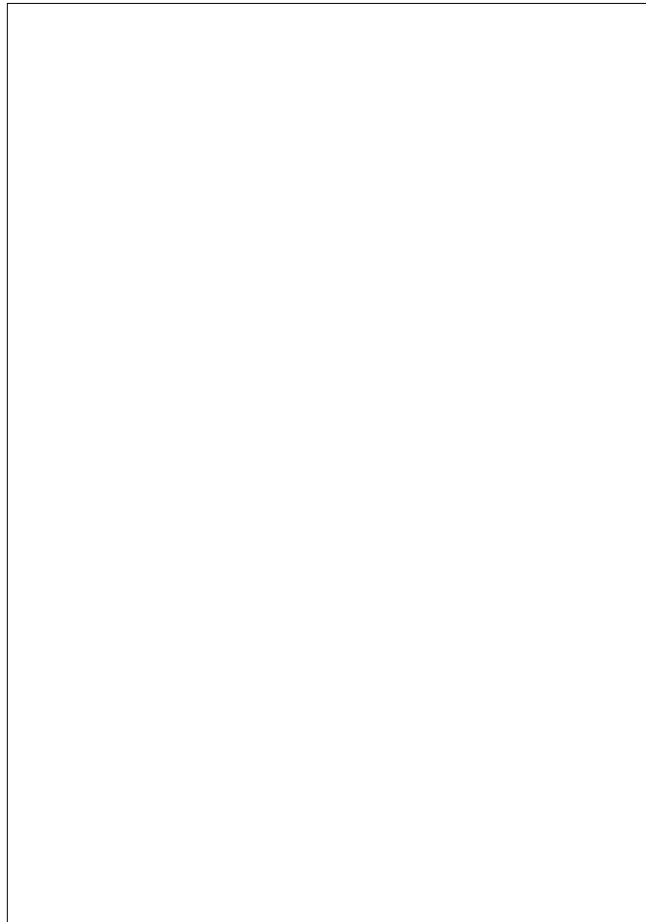
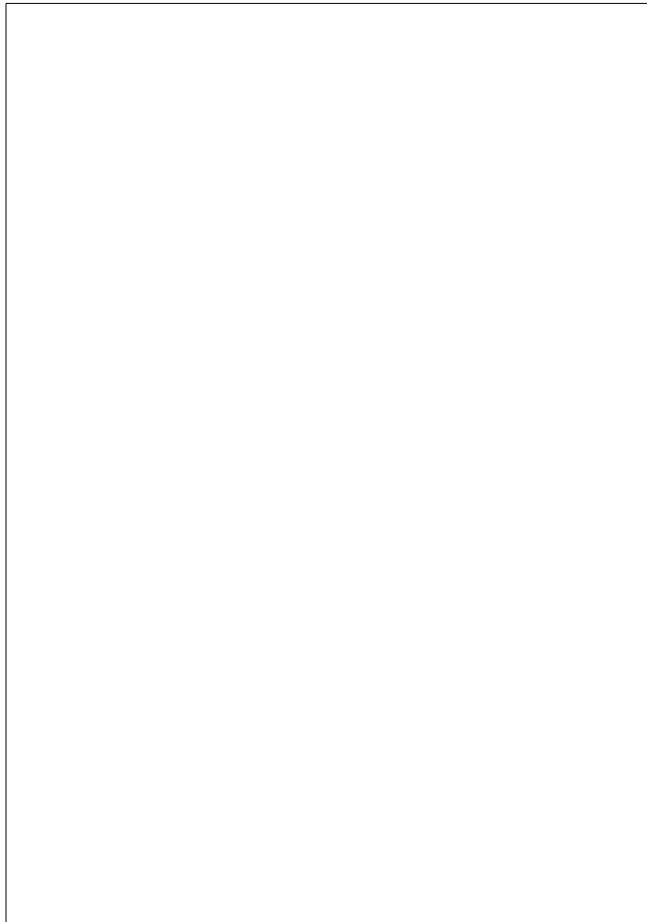
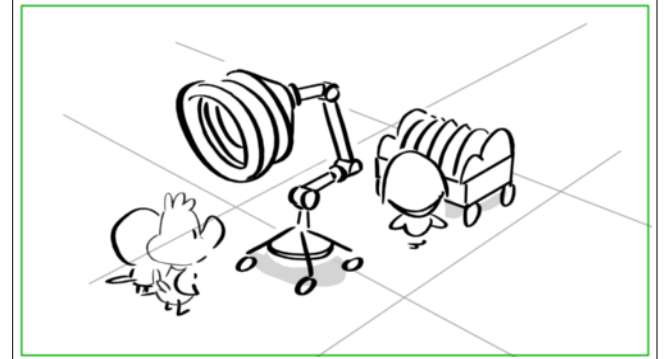
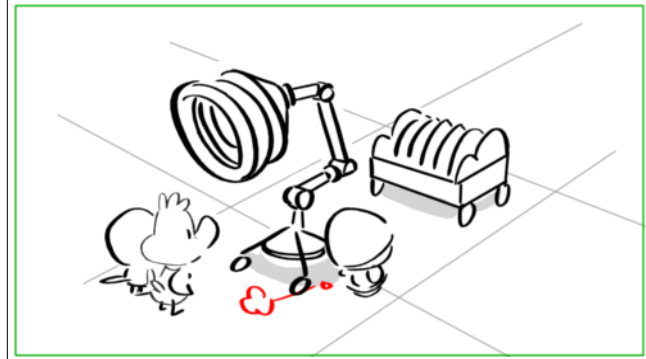
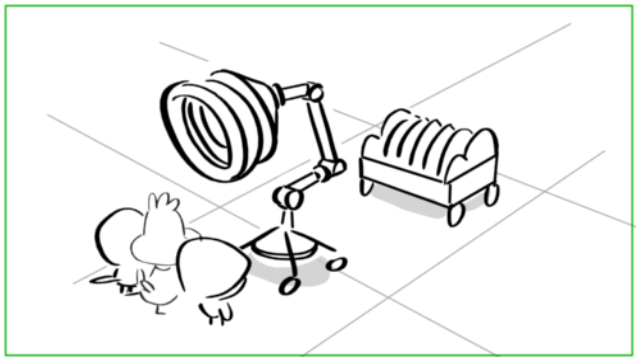



Scene	Duration	Panel	Duration
027	03:16	1	00:11

Scene	Duration	Panel	Duration
027	03:16	2	01:00

Scene	Duration	Panel	Duration
027	03:16	3	01:00

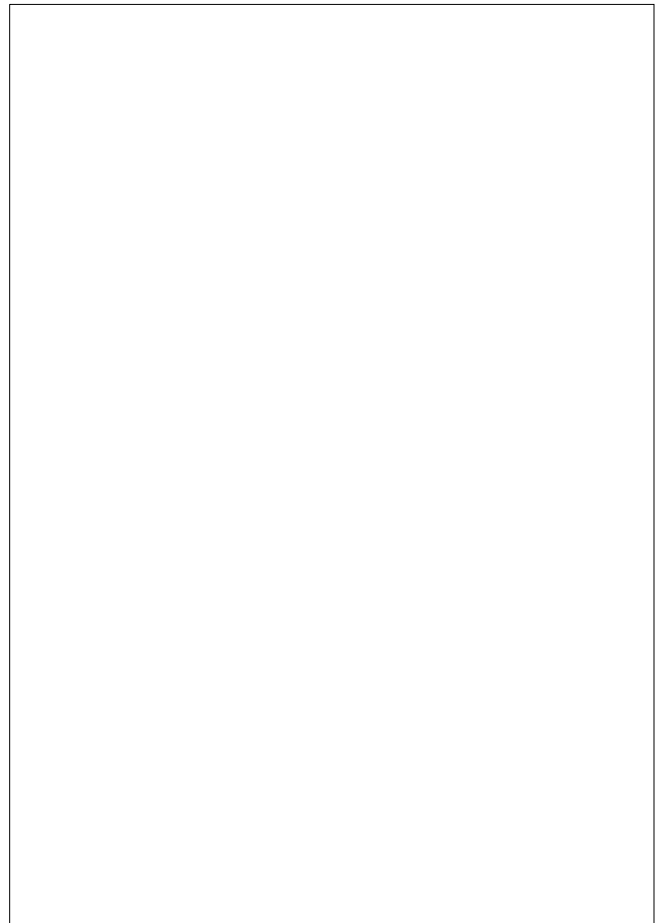
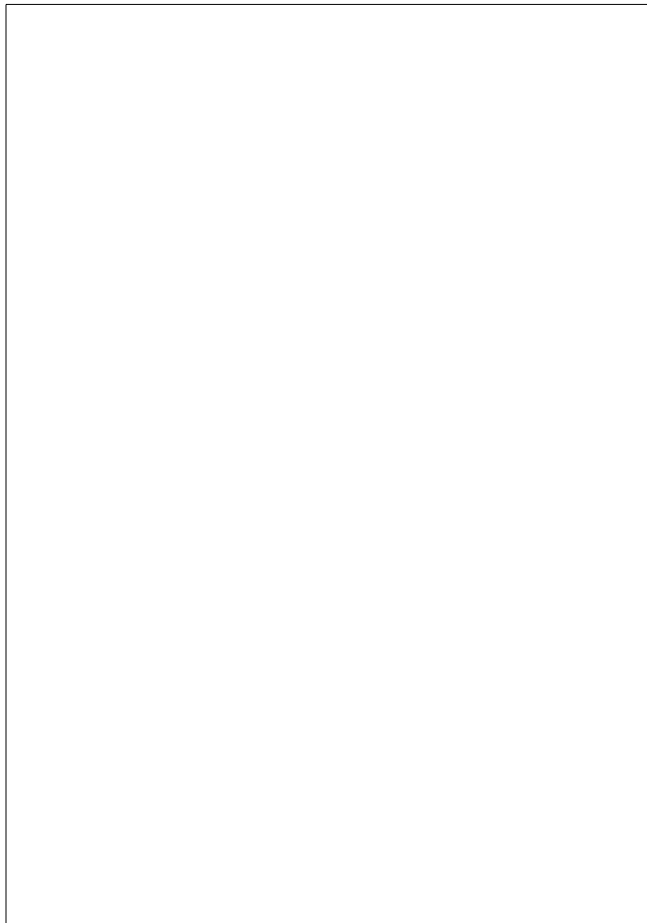
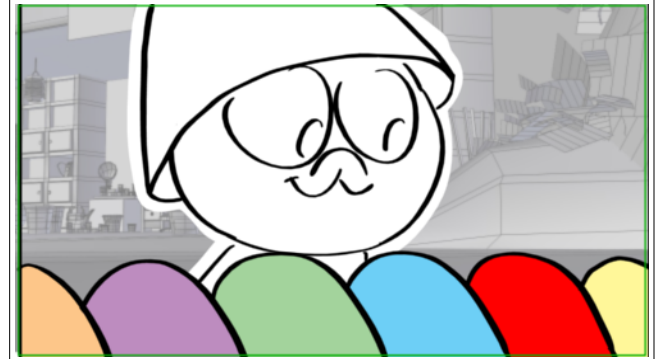
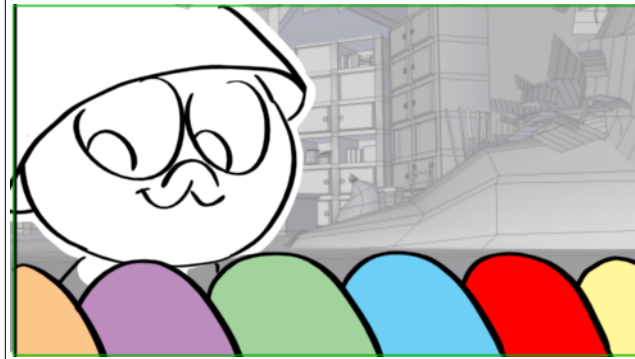
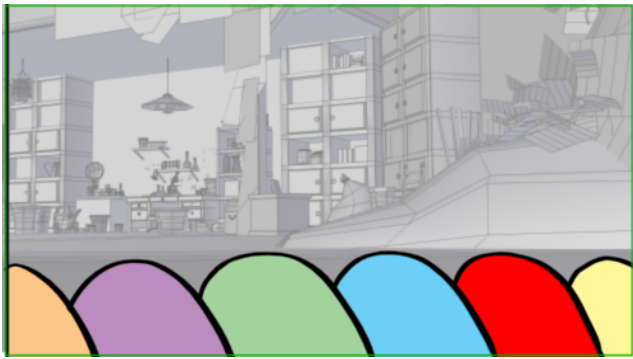

Scene	Duration	Panel	Duration
027	03:16	4	00:05

Scene	Duration	Panel	Duration
027	03:16	5	00:14

Scene	Duration	Panel	Duration
027	03:16	6	00:11



Dialogue
 PICK UP CALIMERO
 Ah!

Scene	Duration	Panel	Duration
028	07:02	1	00:14

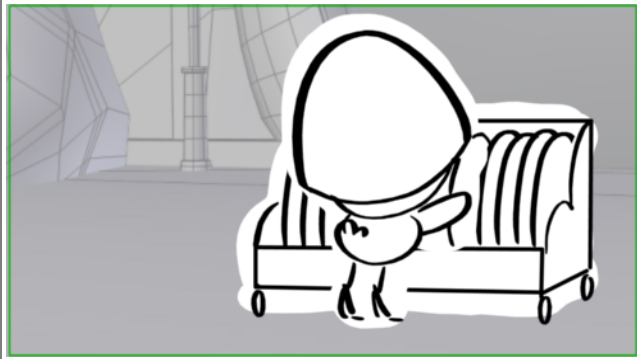

Scene	Duration	Panel	Duration
028	07:02	2	00:11

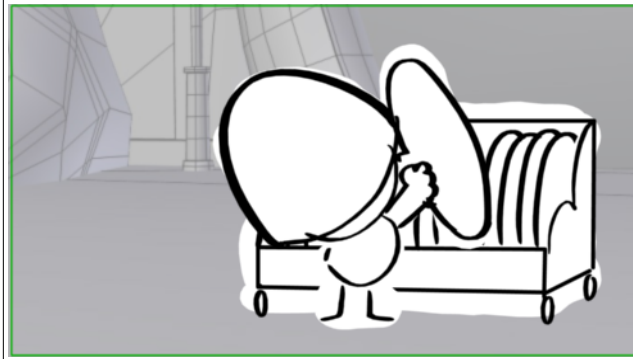

Action Notes

Calimero attrappe un filtre rouge à pois noirs

Scene	Duration	Panel	Duration
028	07:02	3	03:00

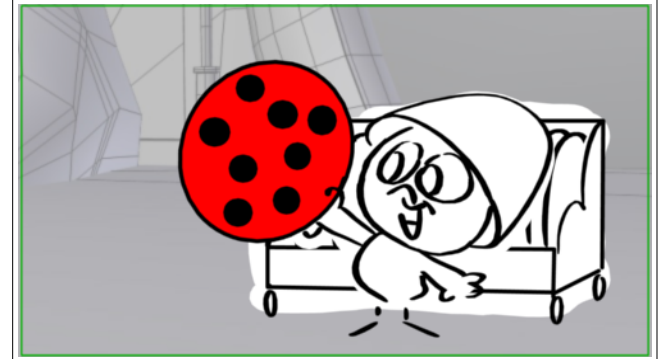

Dialogue

14. CALIMERO MODIF
Voilà le filtre rouge à pois noirs!

Scene	Duration	Panel	Duration
028	07:02	4	01:23

Scene	Duration	Panel	Duration
028	07:02	5	00:18

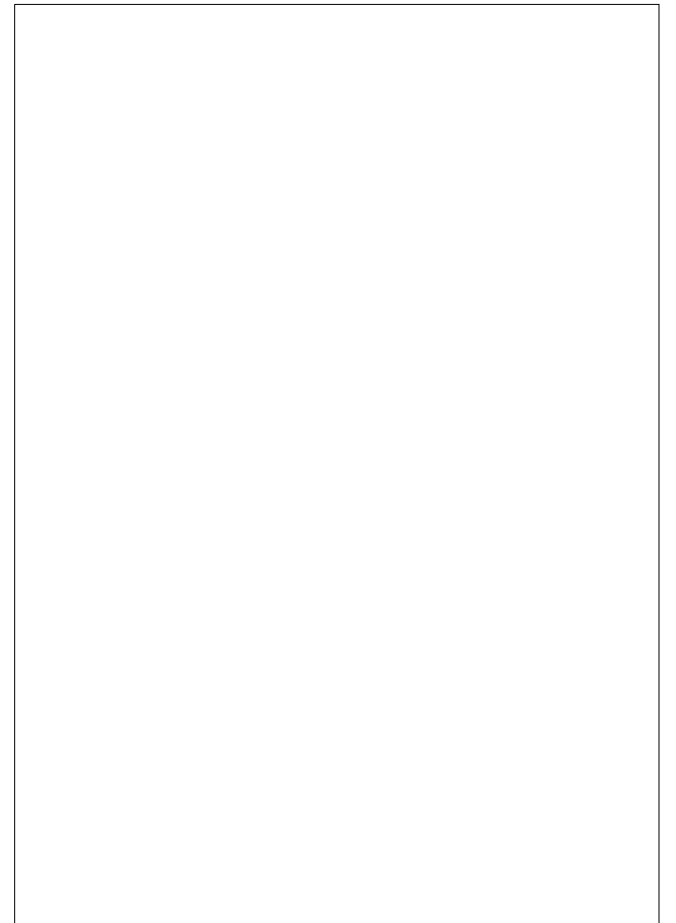
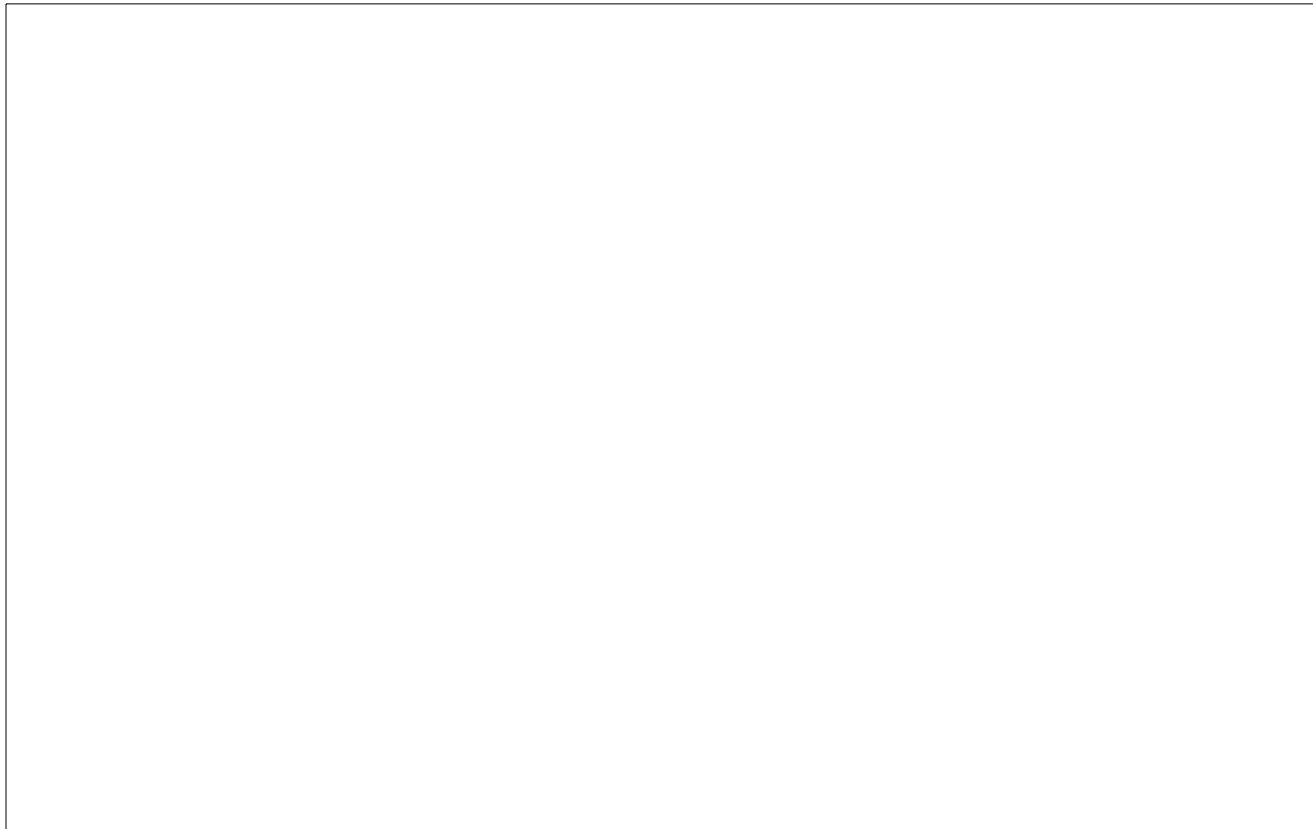
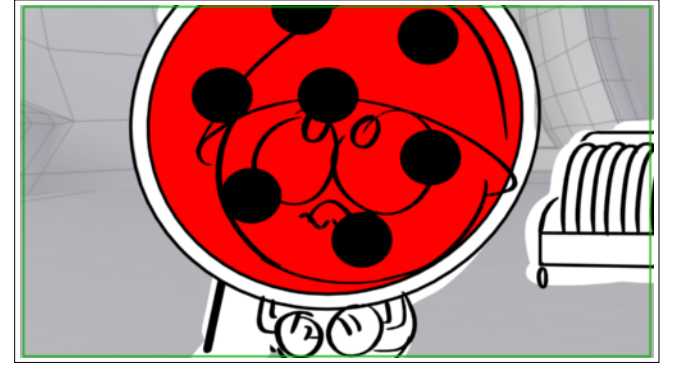
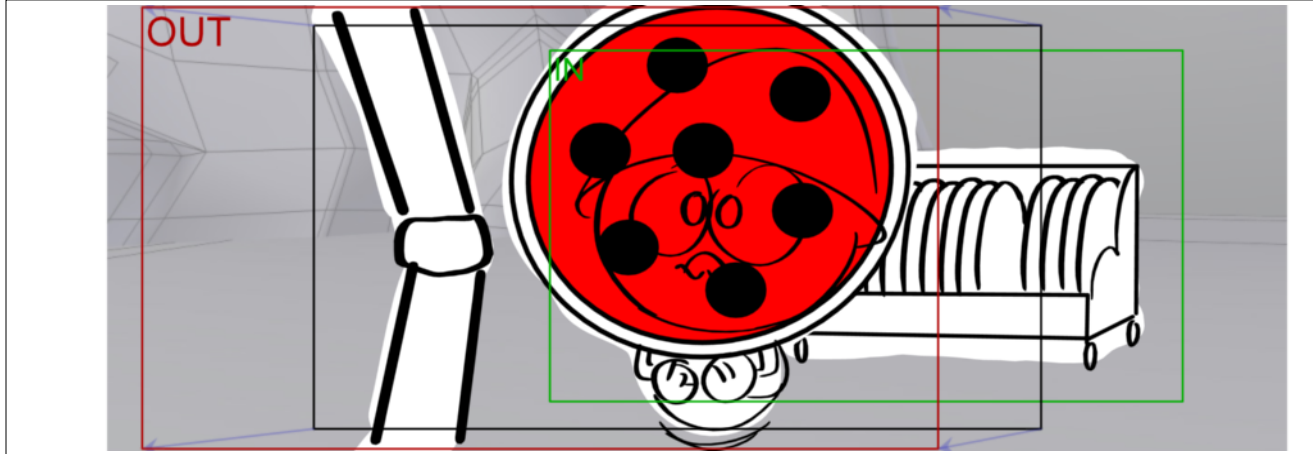

Scene	Duration	Panel	Duration
028	07:02	6	00:11

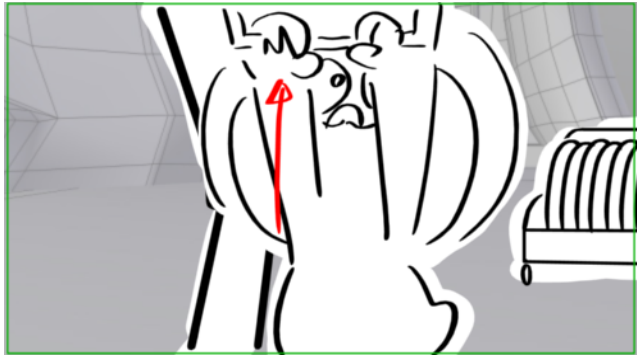

Scene	Duration	Panel	Duration
029	01:07	1	00:05

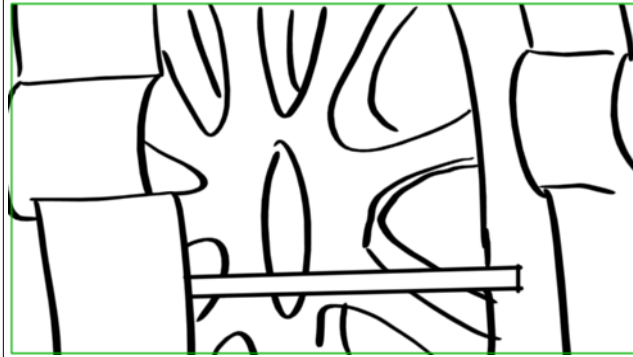

Scene	Duration	Panel	Duration
029	01:07	2	00:14

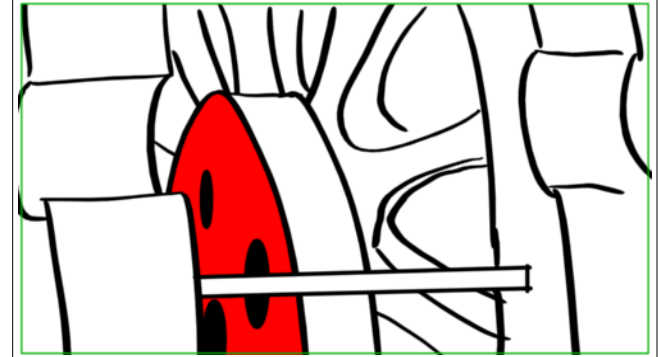

Action Notes

close up filtre inséré dans la lampe

Scene	Duration	Panel	Duration
029	01:07	3	00:13

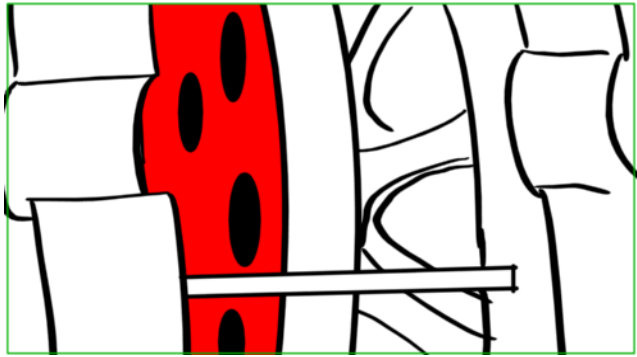

Scene	Duration	Panel	Duration
030	05:01	1	00:09

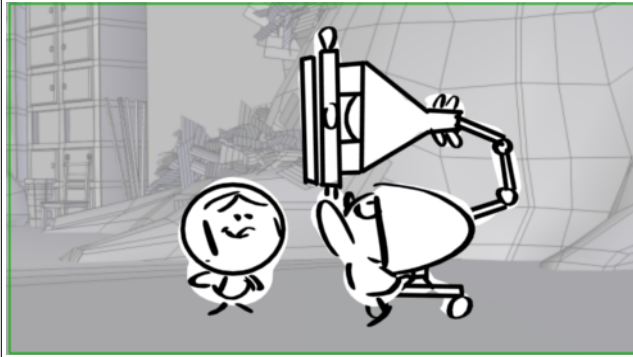

Scene	Duration	Panel	Duration
030	05:01	2	01:00

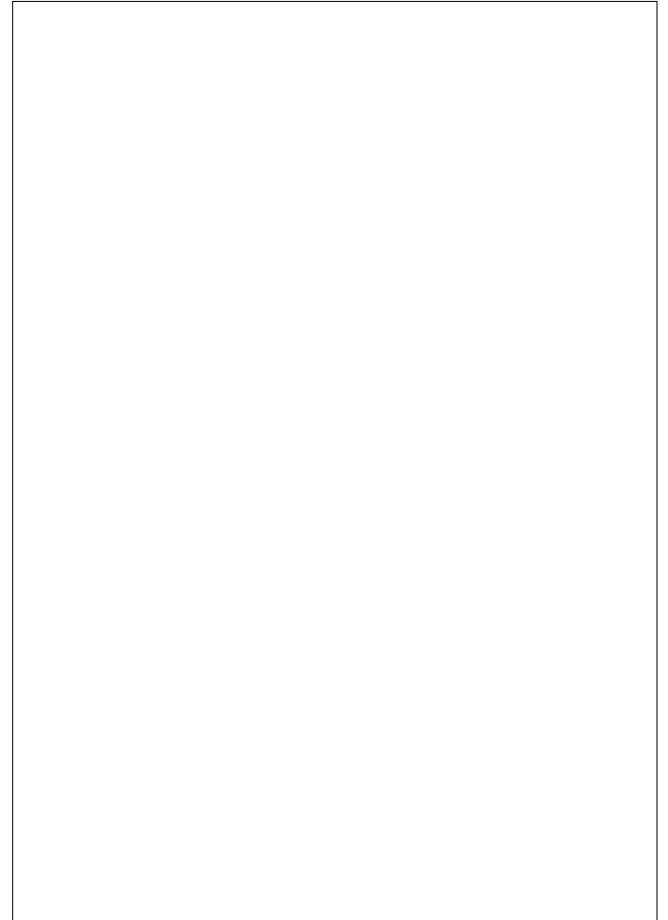
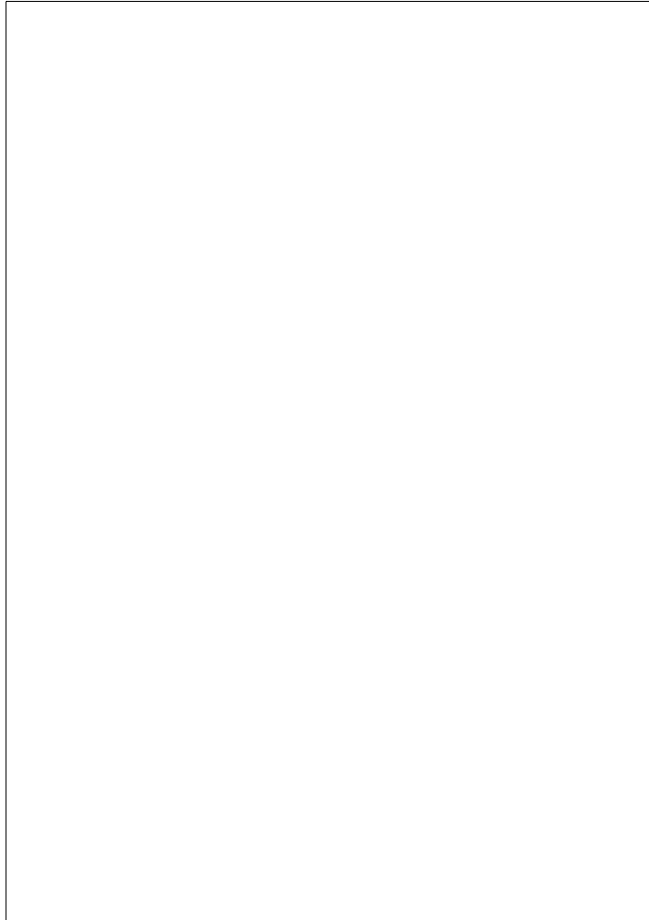
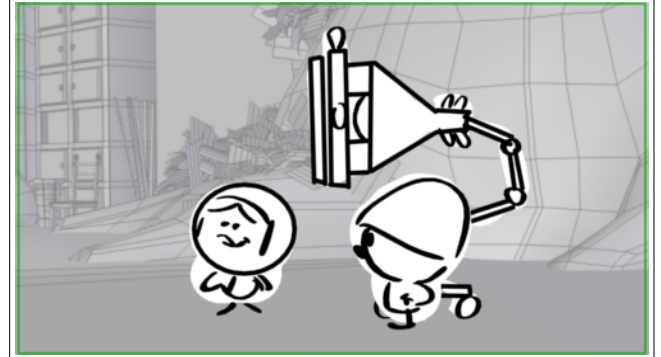

Scene	Duration	Panel	Duration
030	05:01	3	01:00

Scene	Duration	Panel	Duration
030	05:01	4	00:11

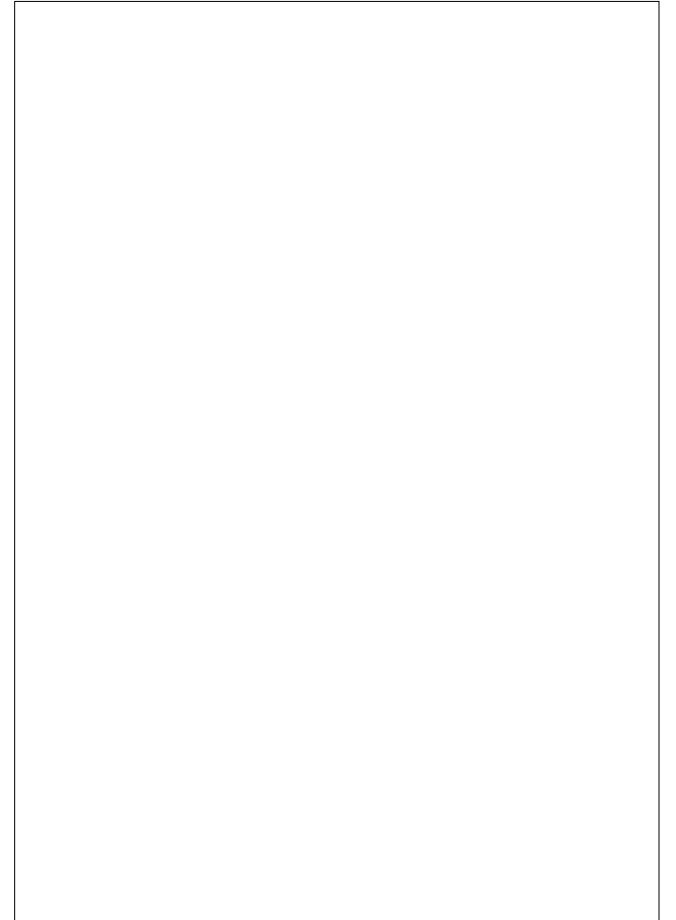
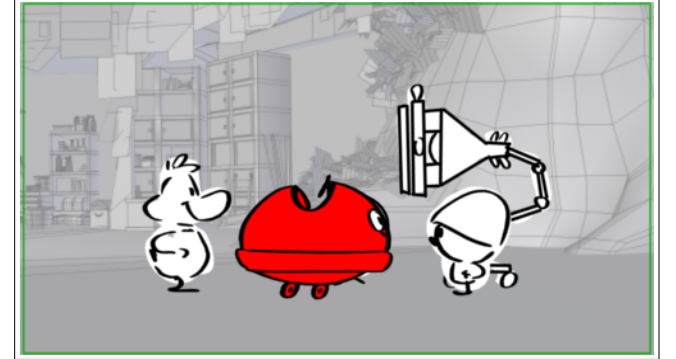
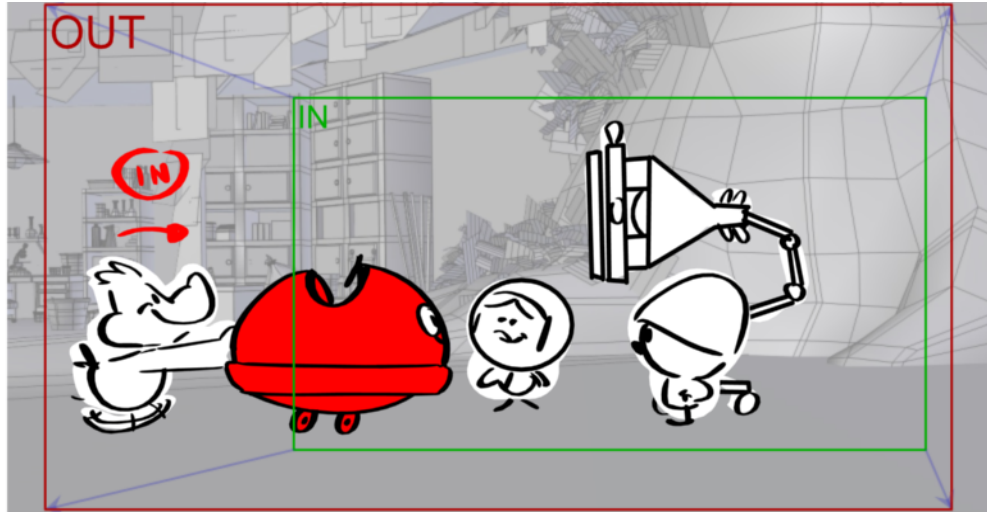

Scene	Duration	Panel	Duration
030	05:01	5	00:14

Scene	Duration	Panel	Duration
030	05:01	6	00:14

Scene	Duration	Panel	Duration
030	05:01	7	00:14

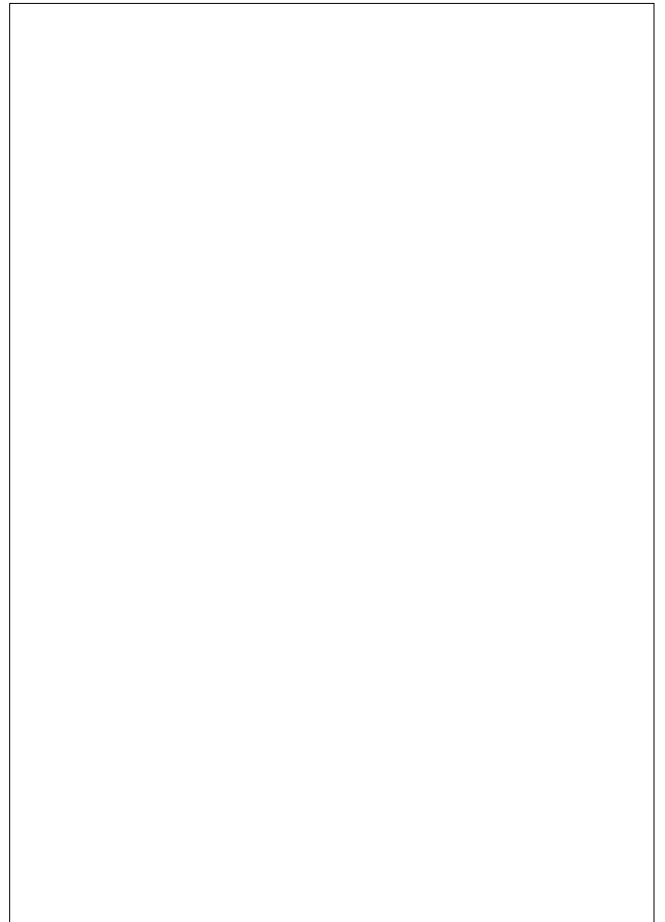
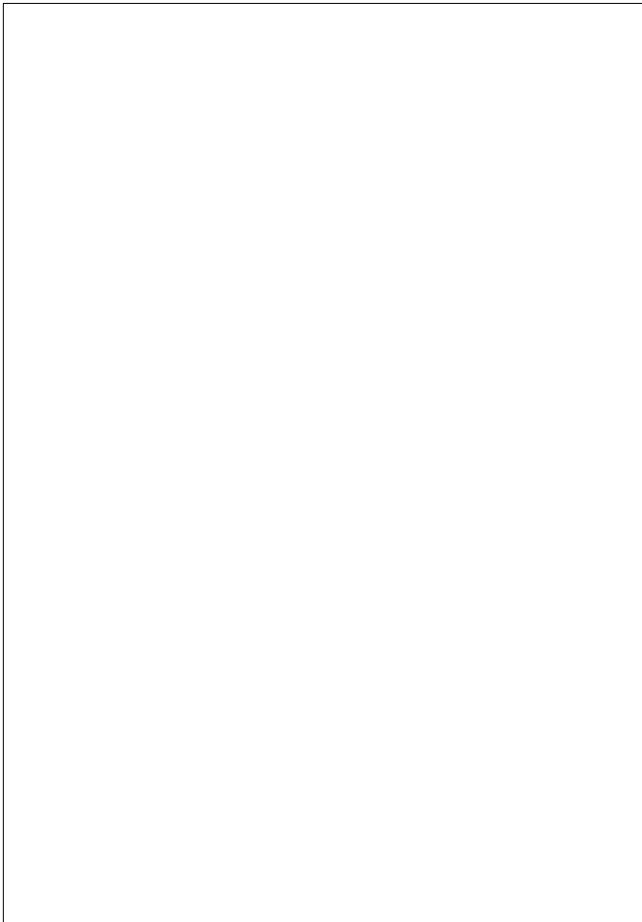
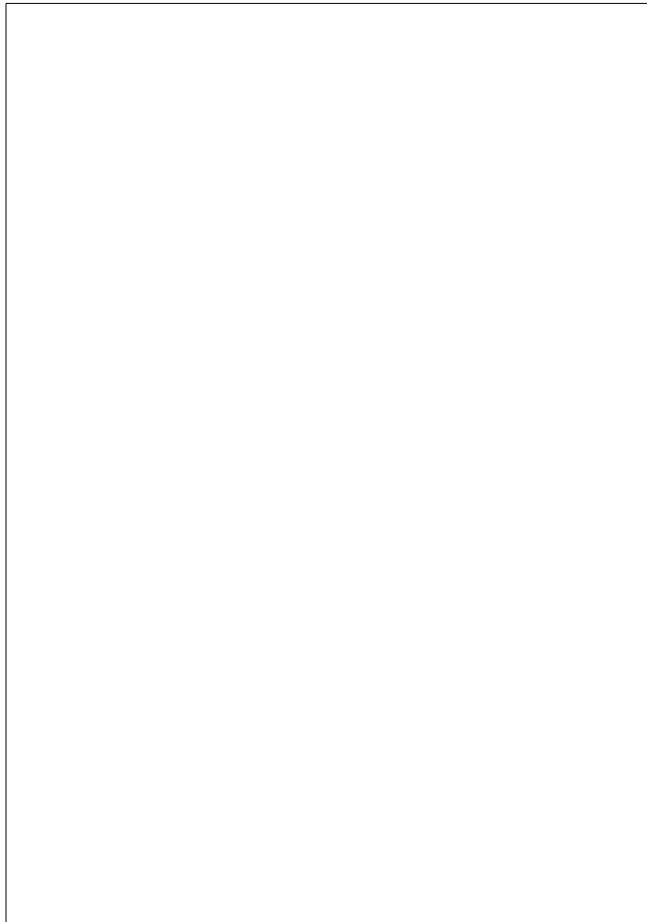
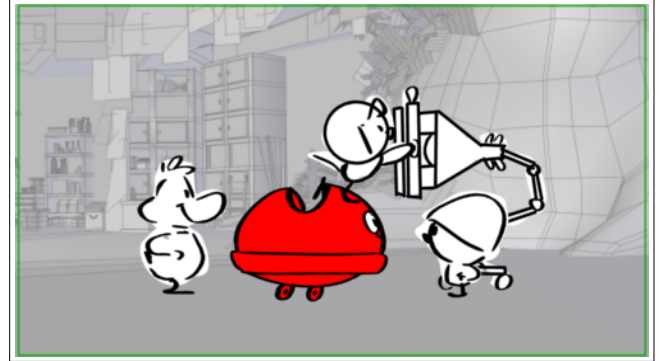

Scene	Duration	Panel	Duration
030	05:01	8	00:14

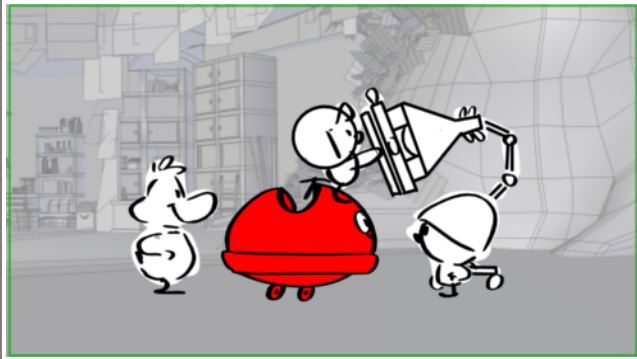

Action Notes

Valeriano fait pencher la lampe vers la voiture

Scene	Duration	Panel	Duration
031	03:08	1	00:10



Scene	Duration	Panel	Duration
031	03:08	2	01:00



Scene	Duration	Panel	Duration
031	03:08	3	00:12

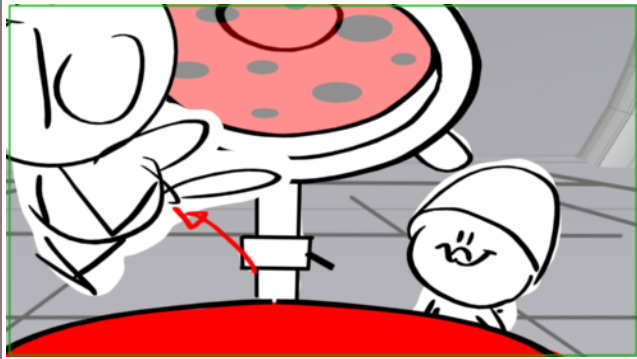

Scene	Duration	Panel	Duration
031	03:08	4	00:11

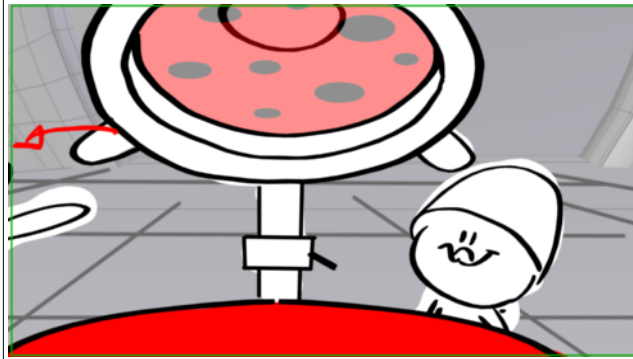

Scene	Duration	Panel	Duration
031	03:08	5	01:00

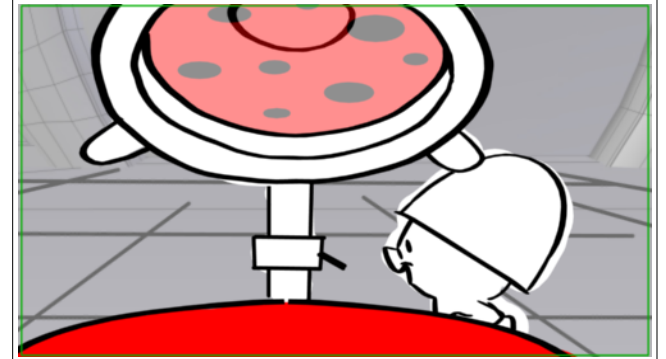

Dialogue

14. CALIMERO (fier d'utiliser la machine)
Allez, c'est parti !



Scene	Duration	Panel	Duration
032	01:02	1	00:10

Scene	Duration	Panel	Duration
032	01:02	2	00:06

Scene	Duration	Panel	Duration
032	01:02	3	00:11

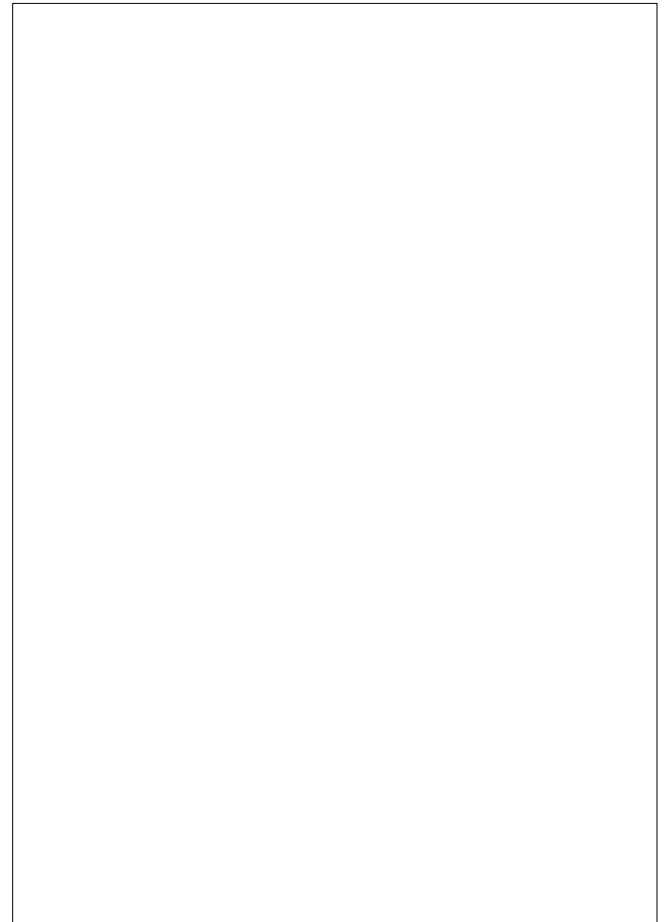
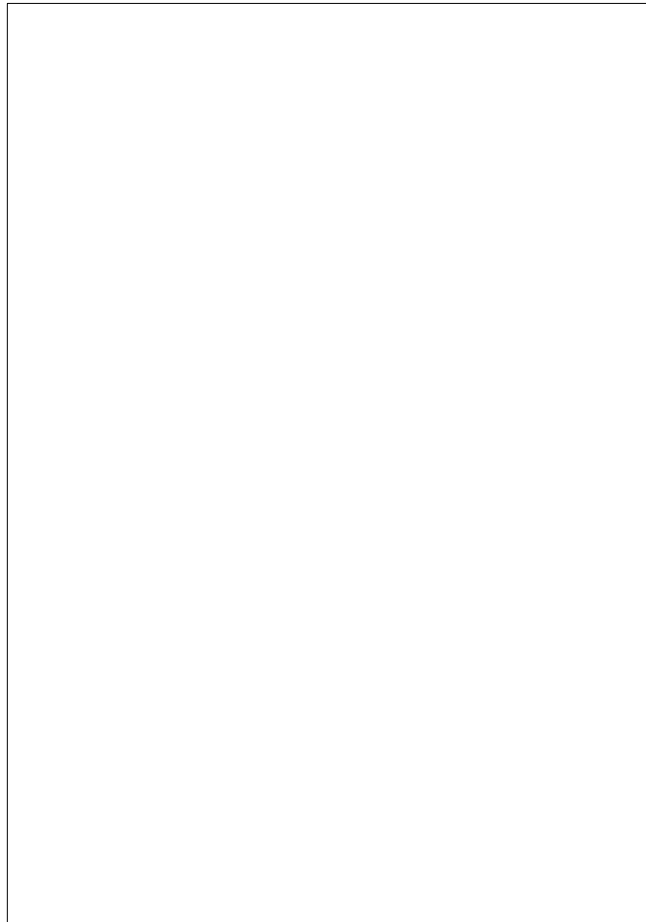
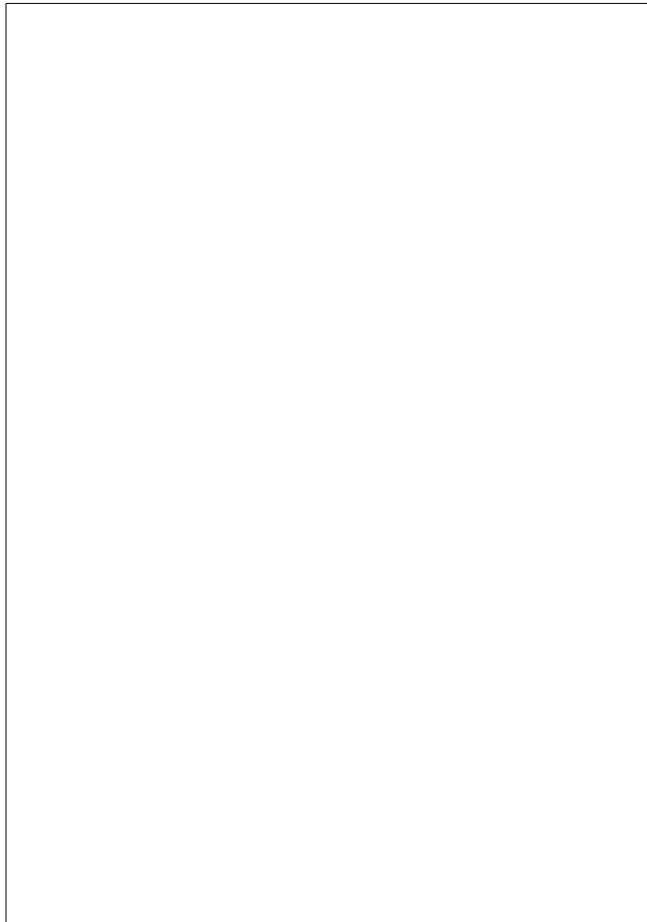
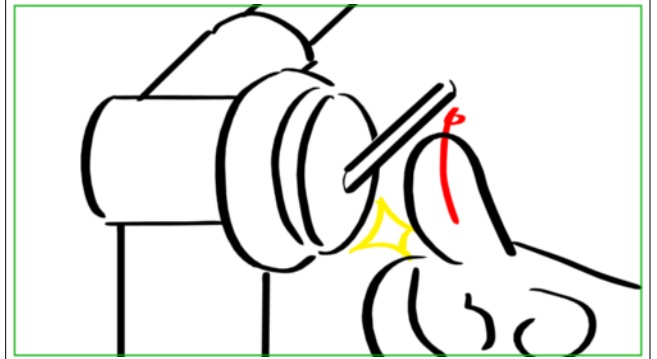
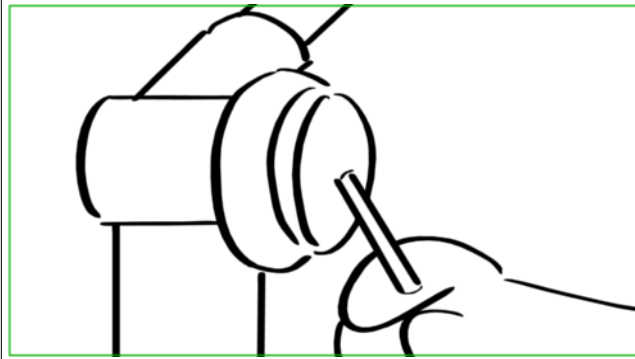
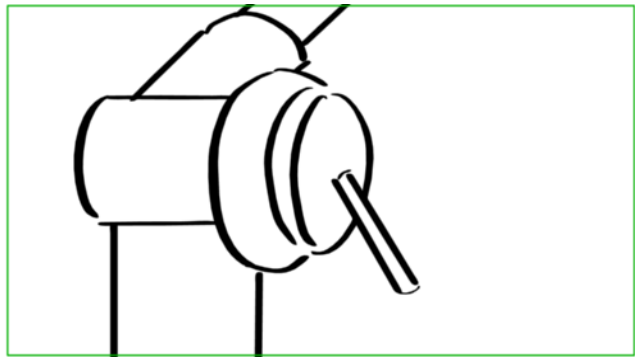

Scene	Duration	Panel	Duration
033	02:04	1	00:10

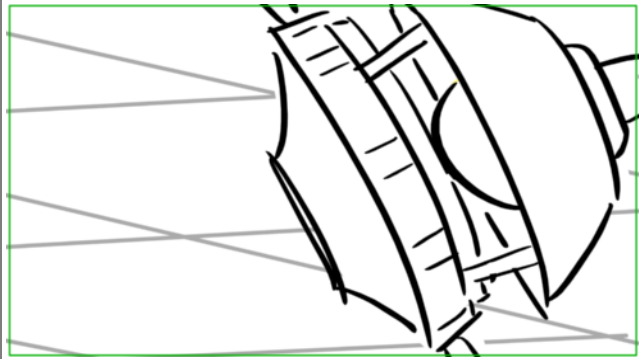

Scene	Duration	Panel	Duration
033	02:04	2	00:12

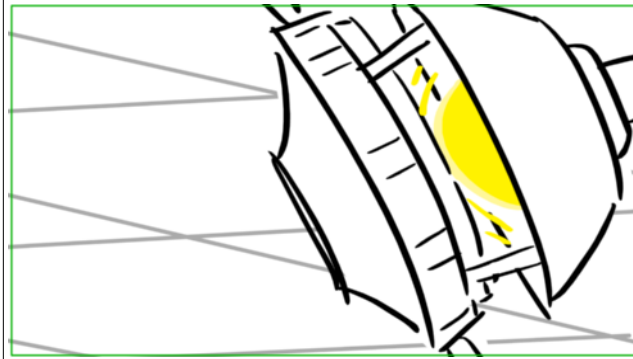

Scene	Duration	Panel	Duration
033	02:04	3	01:07

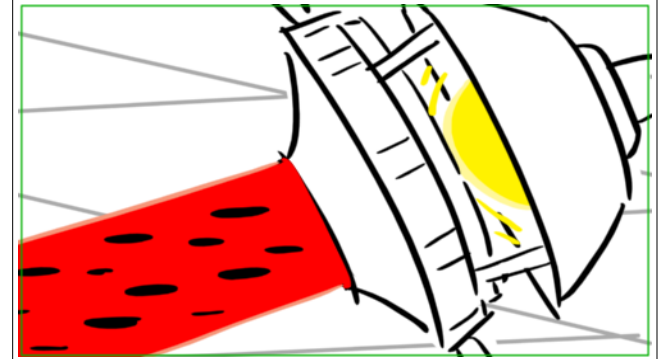

Action Notes

la lampe balance un rayon rouge à pois noirs (FX)

Scene	Duration	Panel	Duration
034	02:23	1	01:08

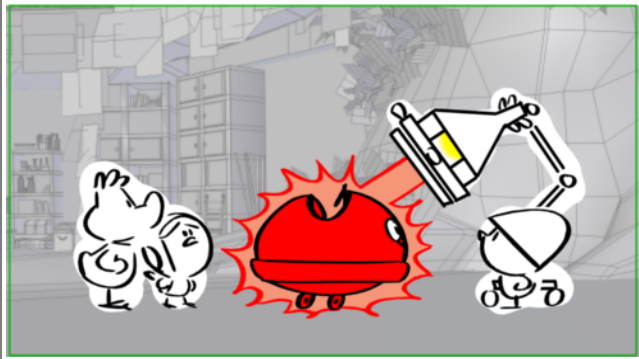

Action Notes
FX rayon

Scene	Duration	Panel	Duration
034	02:23	2	01:15

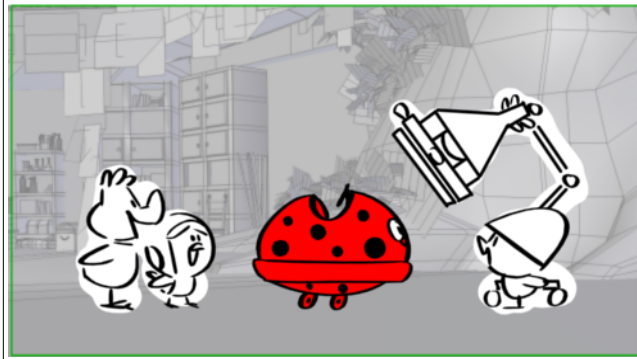

Action Notes
STOP FX
la coccinelle est recouverte de pois noirs

Scene	Duration	Panel	Duration
035	03:16	1	00:17



Dialogue
15. CALIMERO (exalté)
ça a marché !

Scene	Duration	Panel	Duration
035	03:16	2	00:07

Scene	Duration	Panel	Duration
035	03:16	3	01:17

Scene	Duration	Panel	Duration
035	03:16	4	01:00

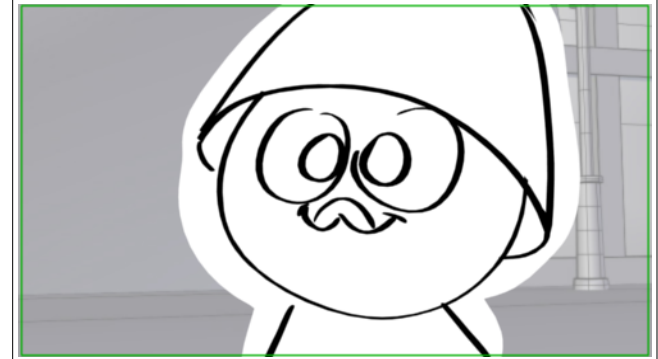

Dialogue

15. CALIMERO (exalté)
ça a marché !

Dialogue

15. CALIMERO (exalté)
ça a marché !

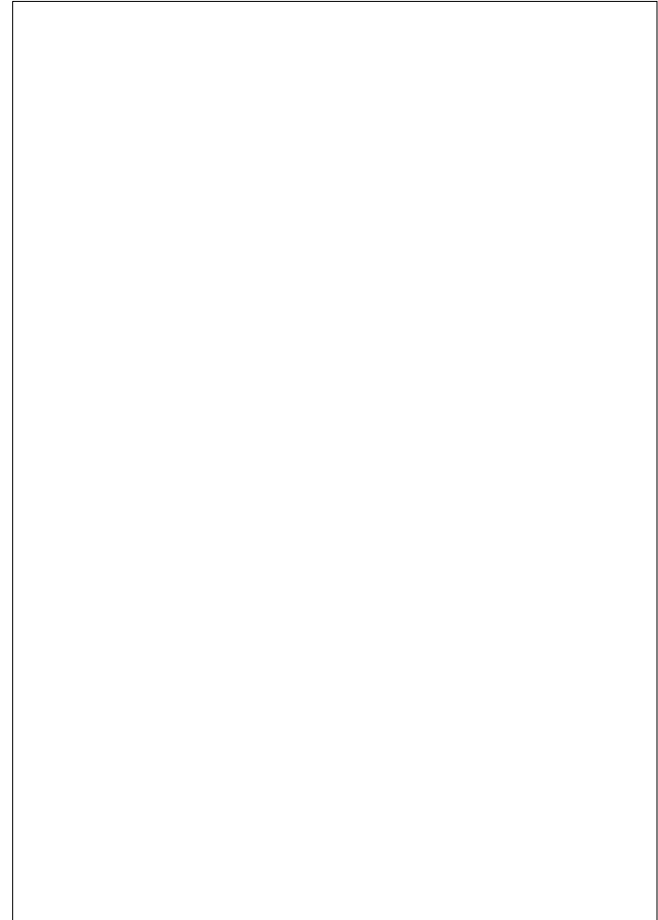

Scene	Duration	Panel	Duration
036	05:11	1	01:00

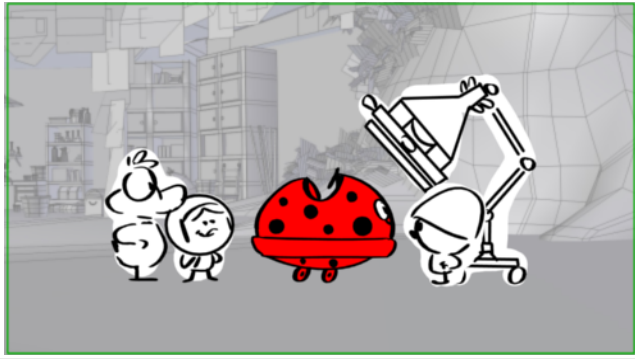

Scene	Duration	Panel	Duration
036	05:11	2	02:00

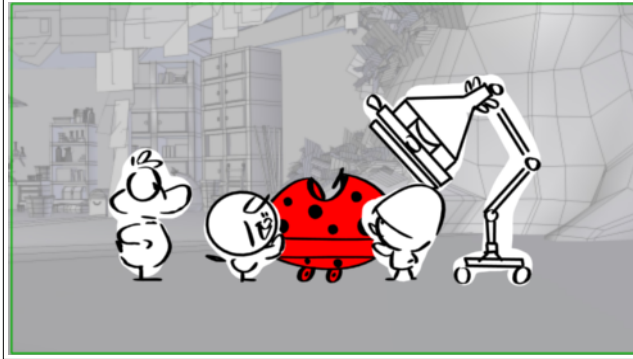
**Dialogue**

17. VALERIANO (épaté)
Trop méga cosmique la coccinelle !

Scene	Duration	Panel	Duration
036	05:11	3	00:10

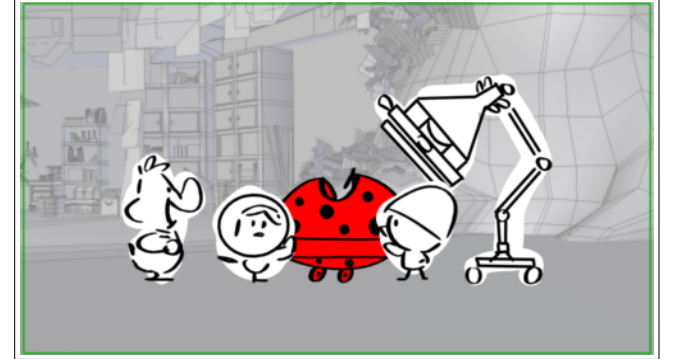
**Dialogue**

16. PIERROT (envieux)
J'en veux une pareille moi aussi !

Scene	Duration	Panel	Duration
036	05:11	4	00:09

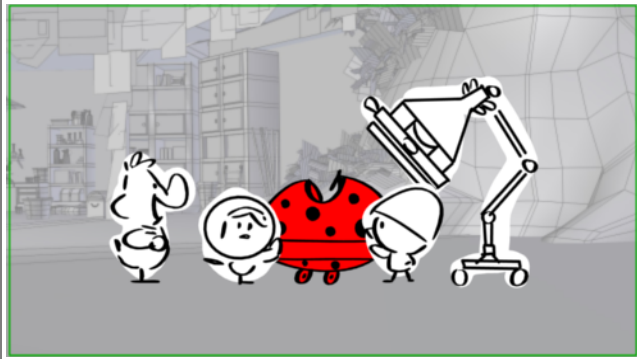

Dialogue

16. PIERROT (envieux)
J'en veux une pareille moi aussi !

Scene	Duration	Panel	Duration
036	05:11	5	00:10

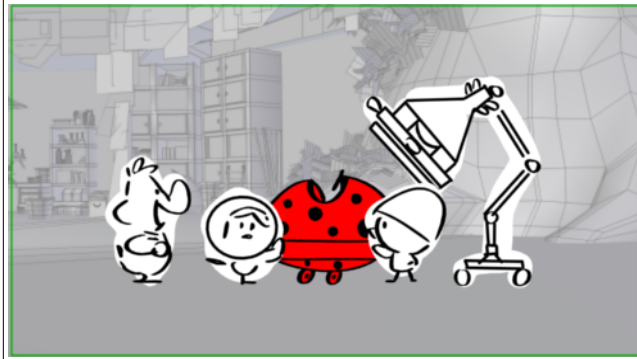

Dialogue

16. PIERROT (envieux)
J'en veux une pareille moi aussi !

Scene	Duration	Panel	Duration
036	05:11	6	00:24

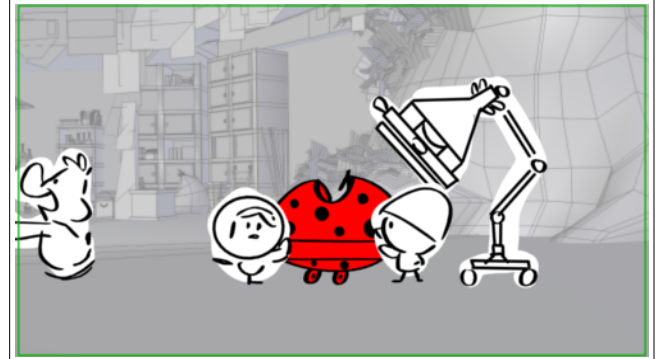

Dialogue

16. PIERROT (envieux)
J'en veux une pareille moi aussi !

Scene	Duration	Panel	Duration
036	05:11	7	00:08

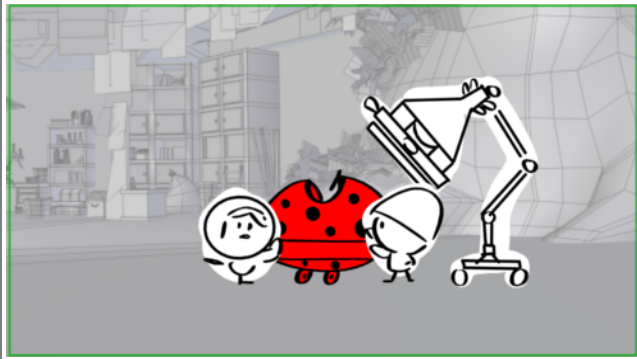

Dialogue

16. PIERROT (envieux)
 J'en veux une pareille moi aussi !

Scene	Duration	Panel	Duration
037	02:00	1	01:00

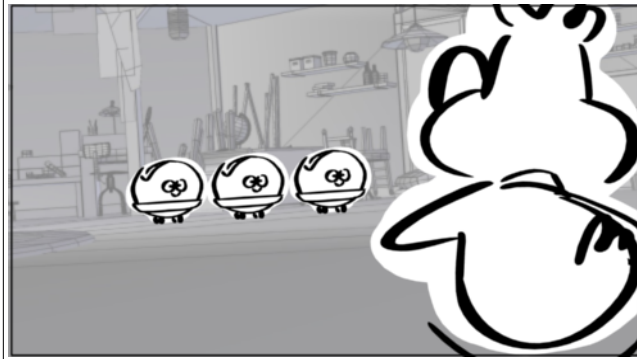

Scene	Duration	Panel	Duration
037	02:00	2	01:00

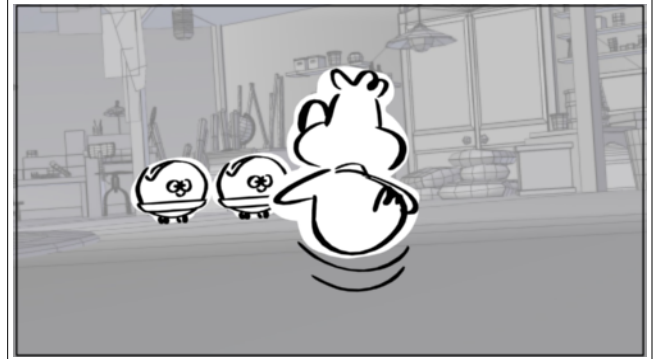



Scene	Duration	Panel	Duration
038	03:04	1	00:16

Scene	Duration	Panel	Duration
038	03:04	2	00:11

Scene	Duration	Panel	Duration
038	03:04	3	00:14

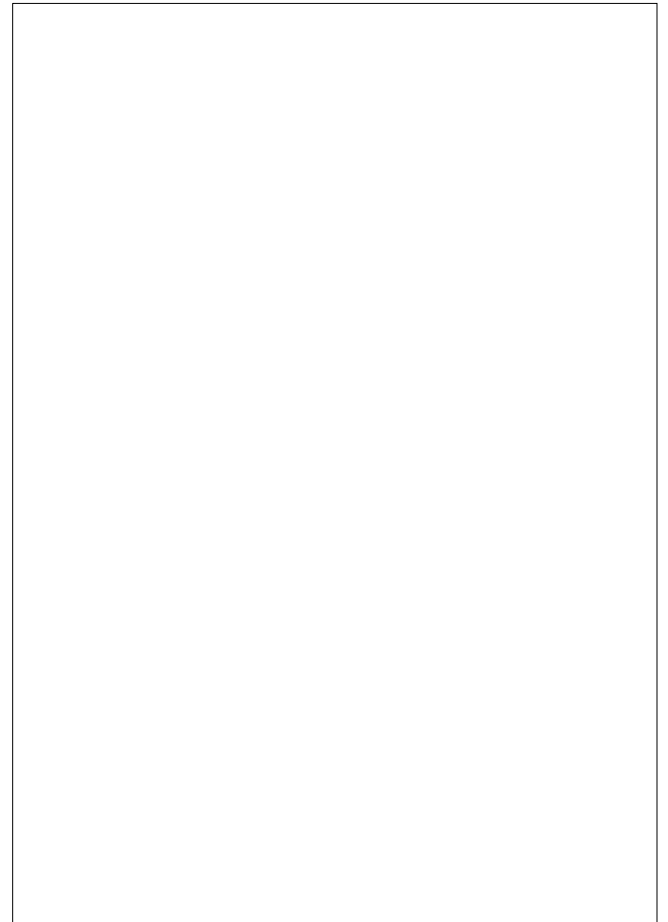
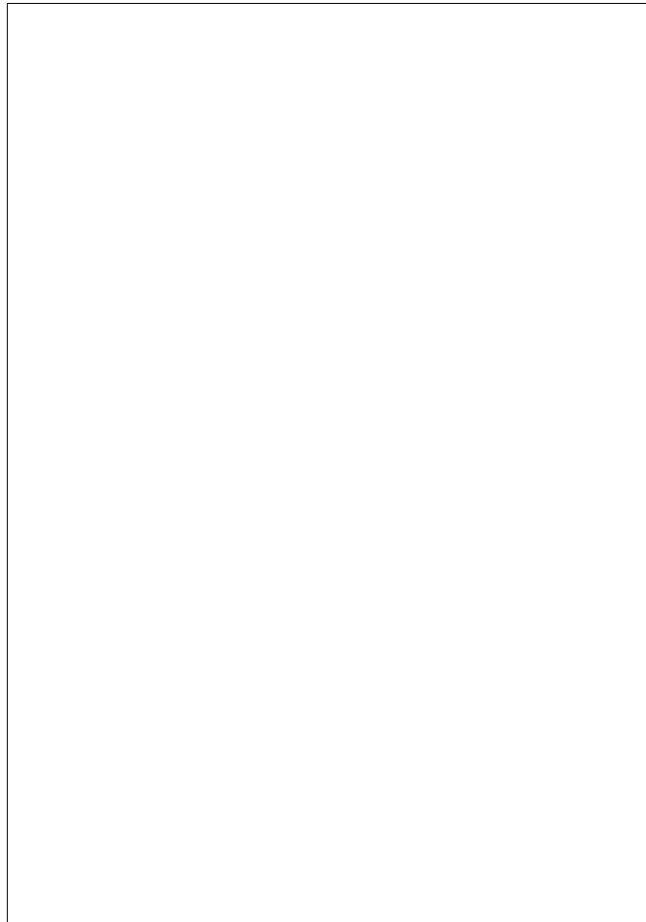
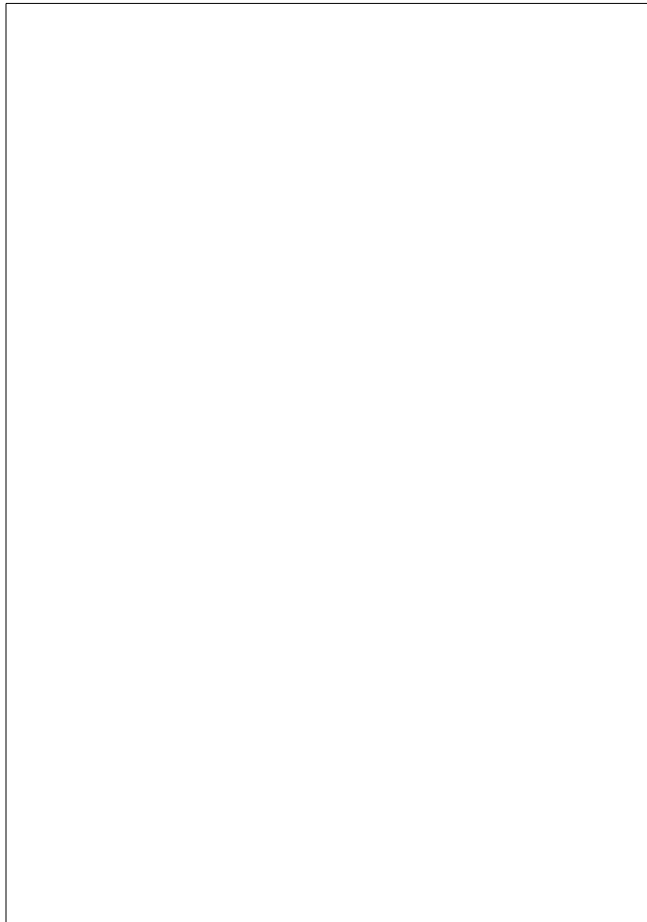
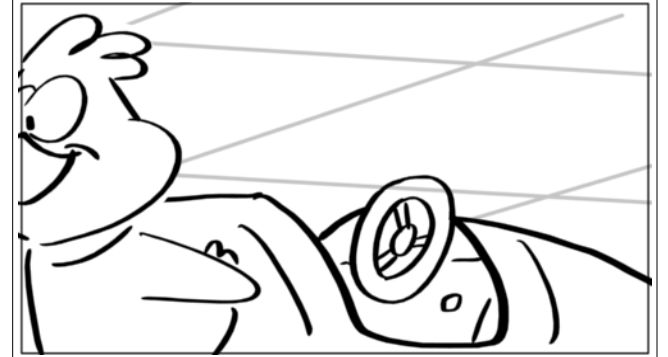
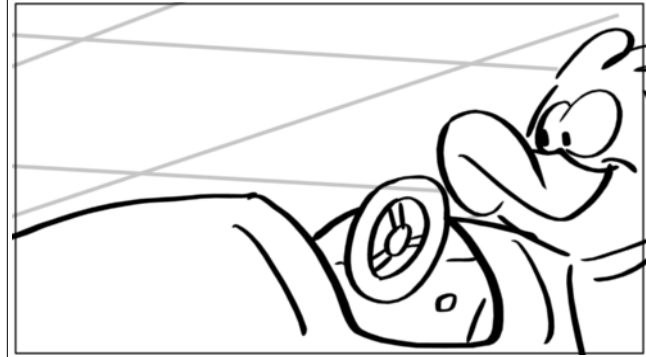
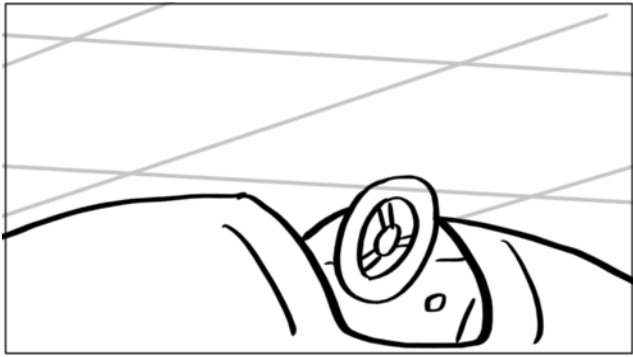

Scene	Duration	Panel	Duration
038	03:04	4	00:13

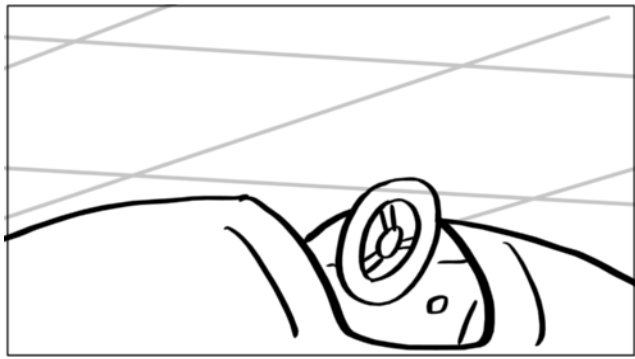

Scene	Duration	Panel	Duration
038	03:04	5	01:00

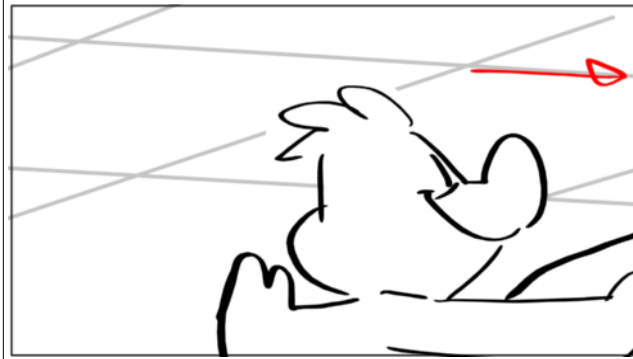

Scene	Duration	Panel	Duration
039	01:18	1	00:16

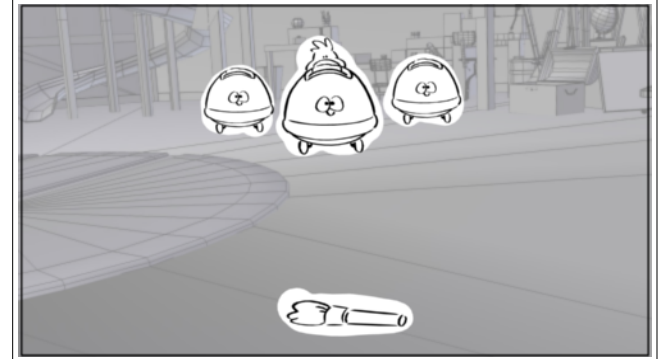

Dialogue

18. PIERROT (excité)
Chaud devant !

Action Notes

pinceau au sol sur le trajet de pierrot

Scene	Duration	Panel	Duration
039	01:18	2	00:14

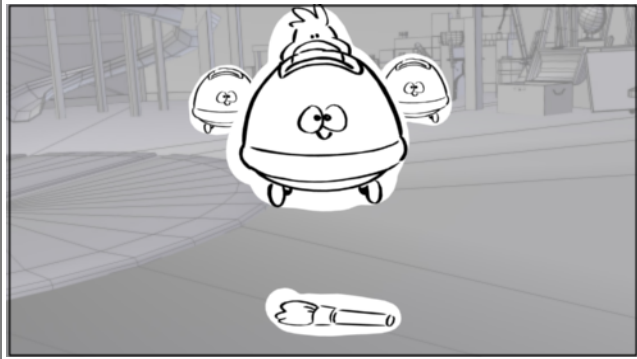

Dialogue

18. PIERROT (excité)
Chaud devant !

Scene	Duration	Panel	Duration
039	01:18	3	00:13

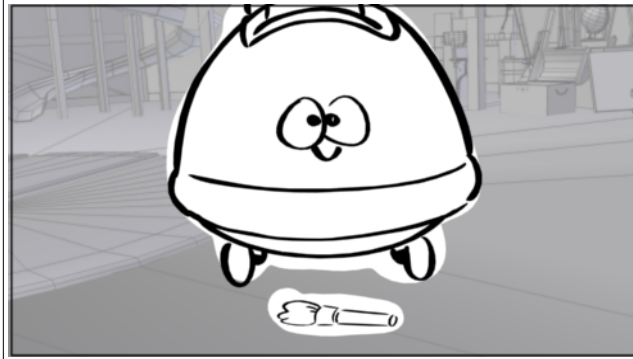

Dialogue

18. PIERROT (excité)
Chaud devant !

Scene	Duration	Panel	Duration
040	01:24	1	00:07

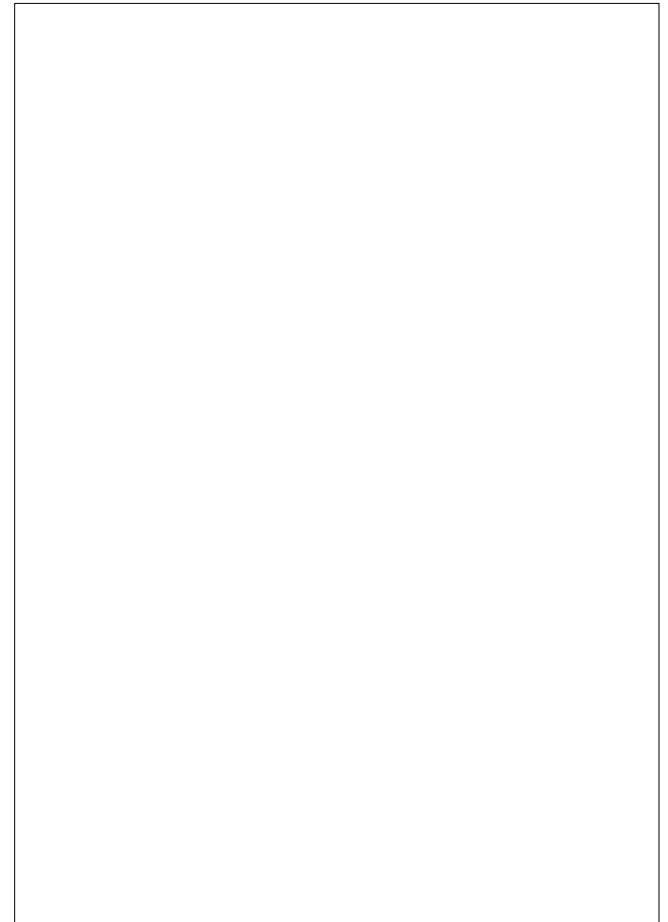
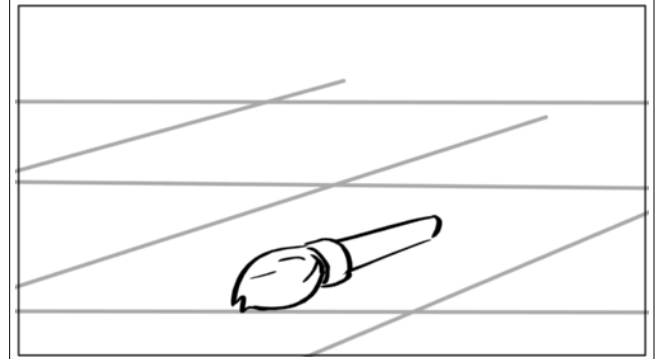



Scene	Duration	Panel	Duration
040	01:24	2	00:13

Scene	Duration	Panel	Duration
040	01:24	3	00:14

Scene	Duration	Panel	Duration
040	01:24	4	00:06

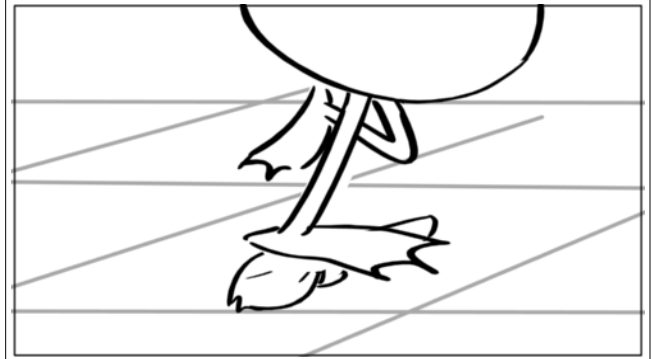
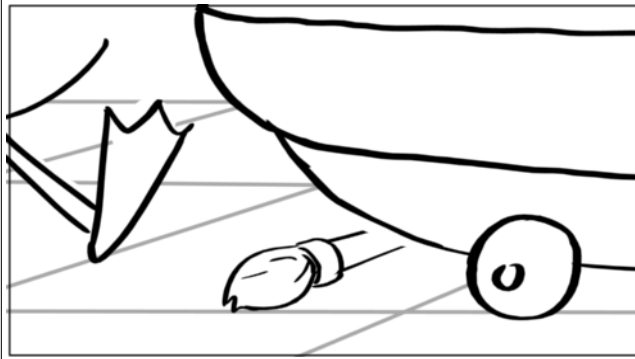
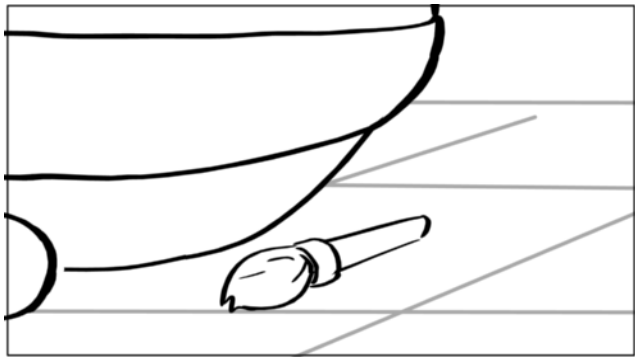

Action Notes

Pierrot marche sur le pinceau et glisse



Scene	Duration	Panel	Duration
040	01:24	5	00:09

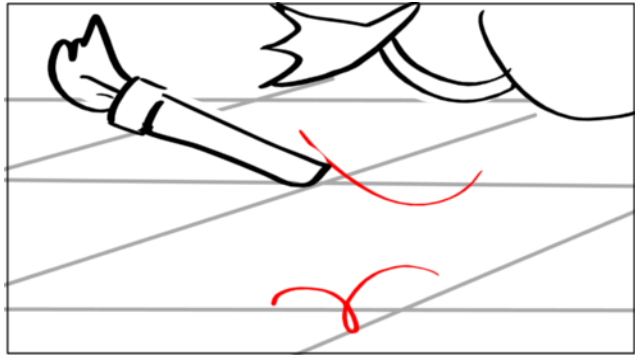

Scene	Duration	Panel	Duration
041	00:21	1	00:06

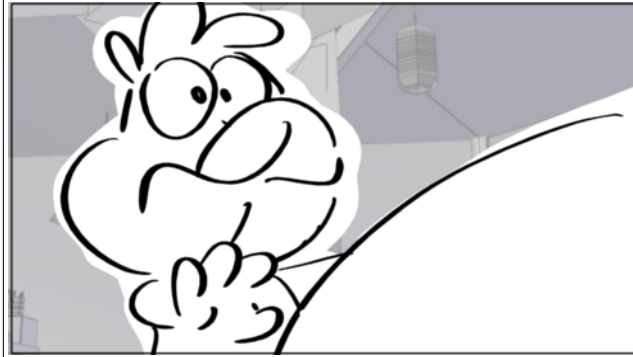

Scene	Duration	Panel	Duration
041	00:21	2	00:08

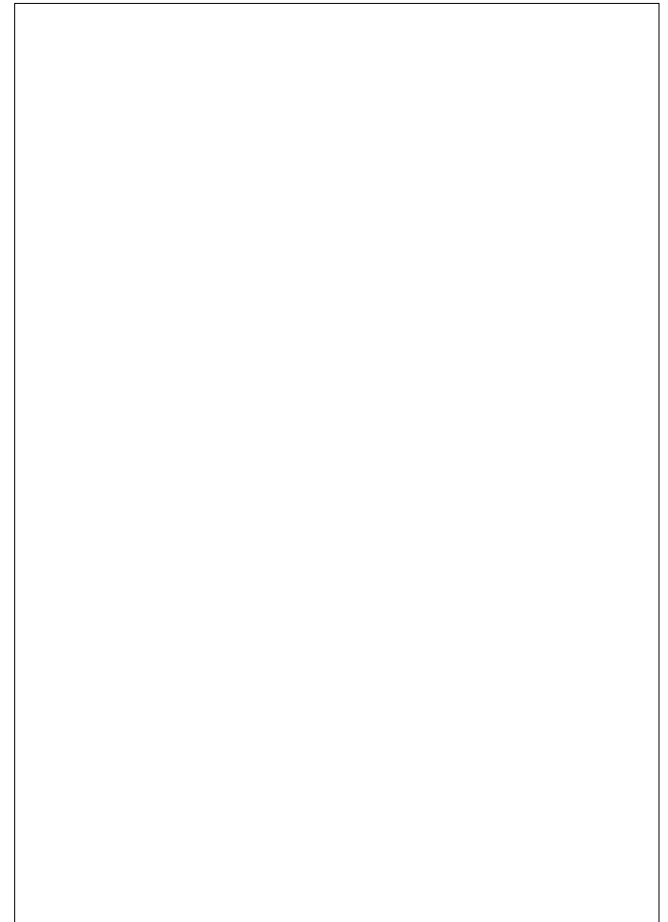
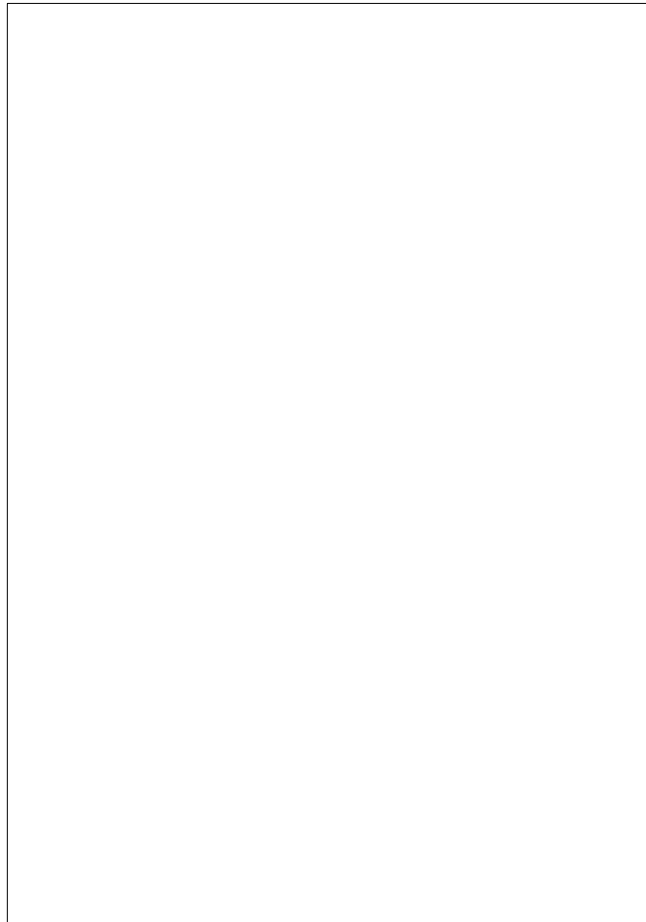
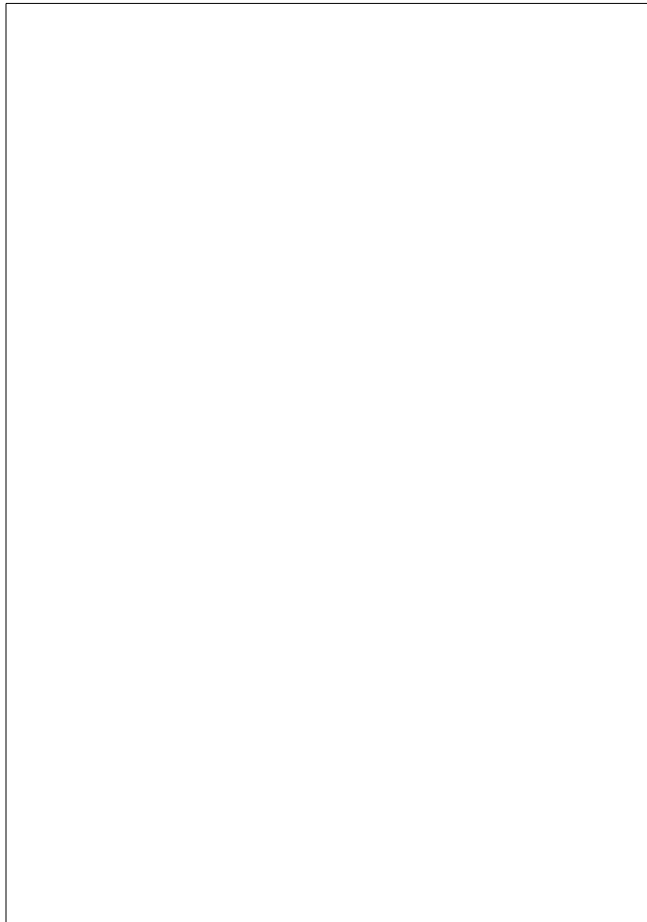



Scene	Duration	Panel	Duration
041	00:21	3	00:07

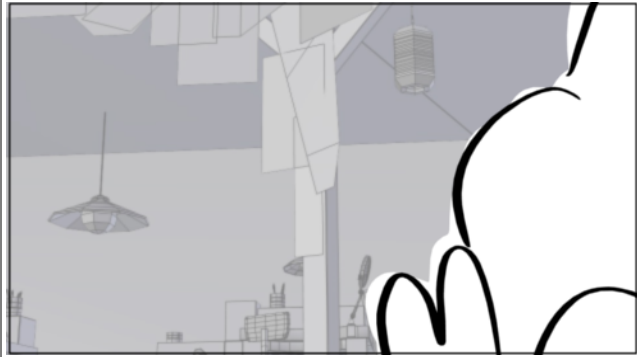

Scene	Duration	Panel	Duration
042	01:10	1	00:06

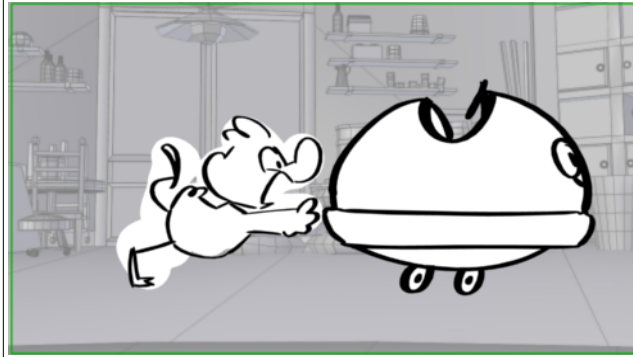

NO PANEL

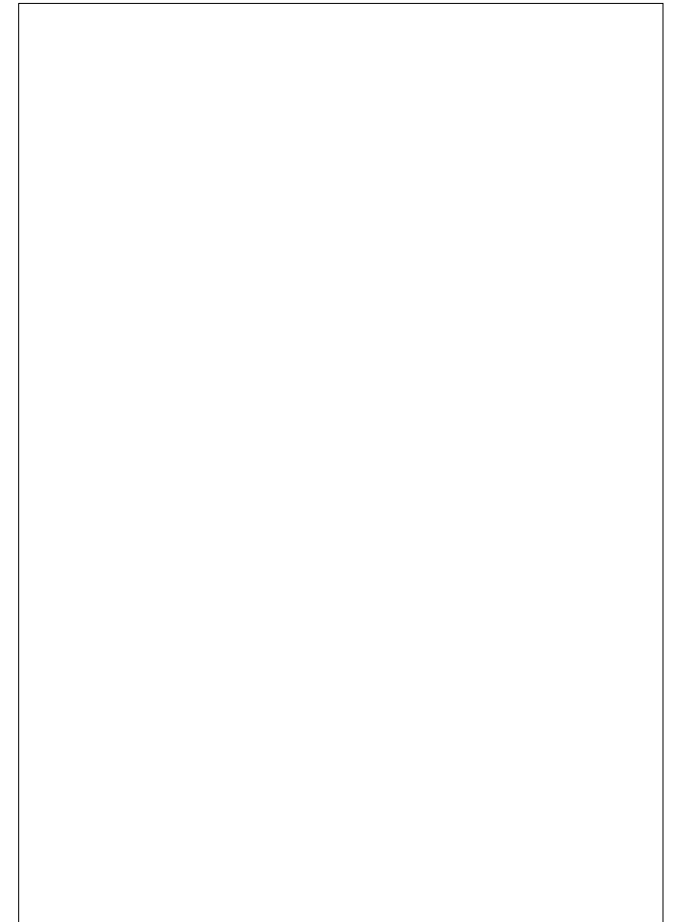
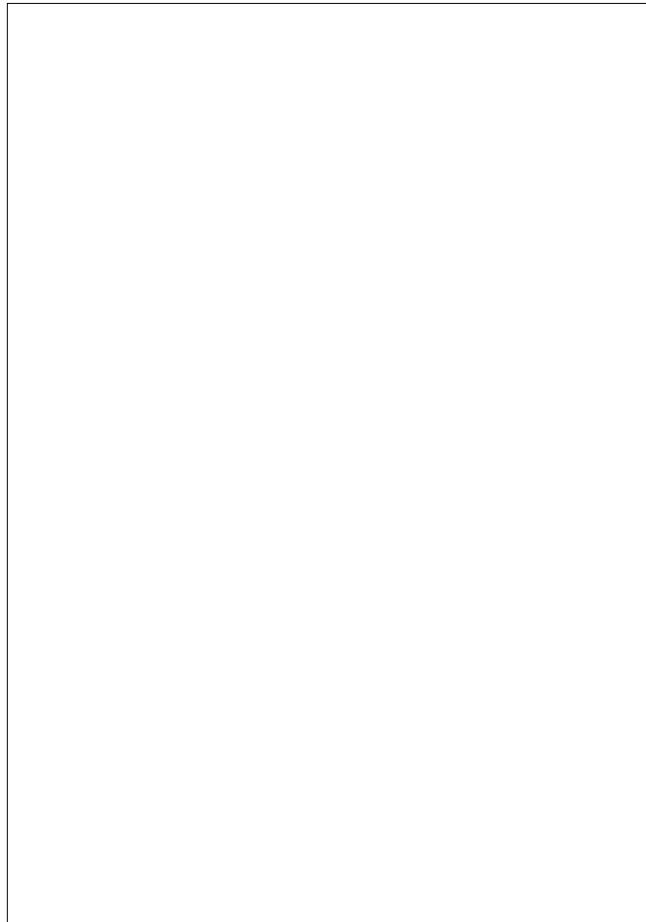
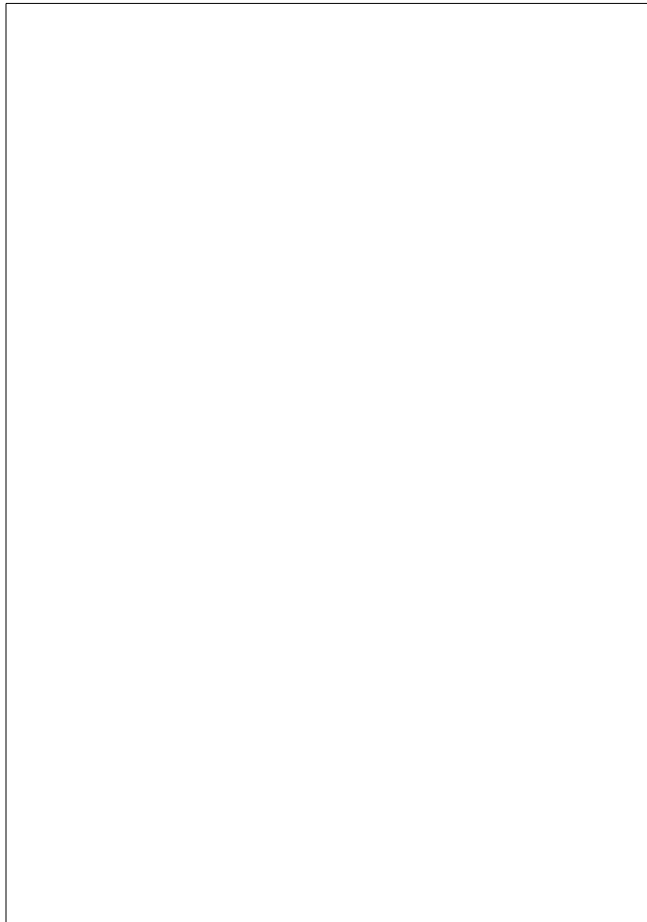
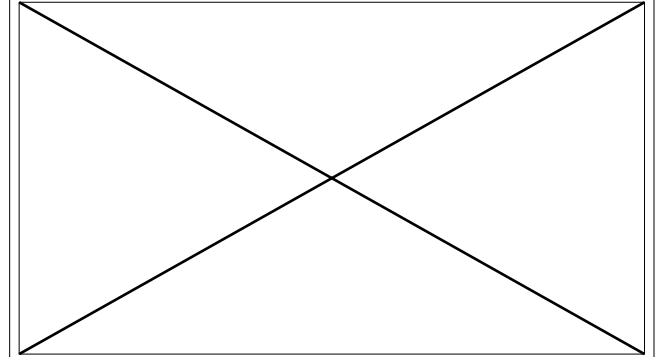



Scene	Duration	Panel	Duration
042	01:10	2	00:09

NO PANEL

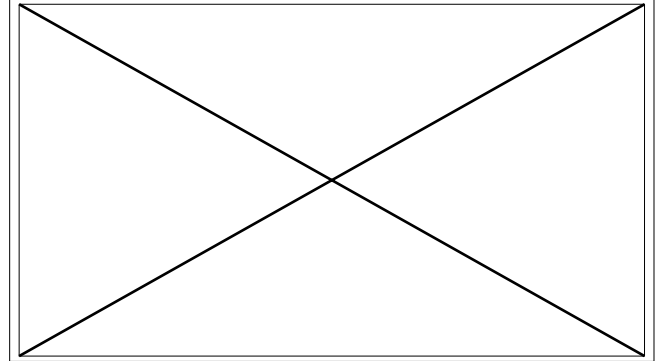
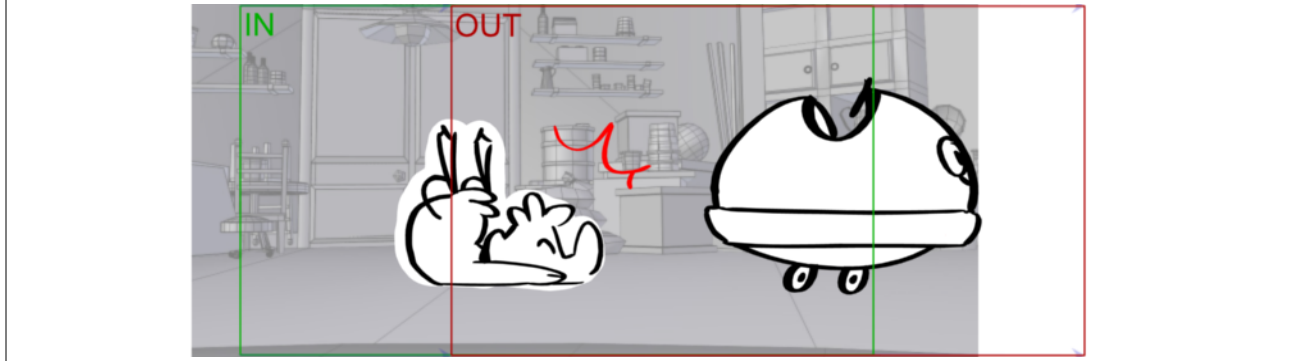

Action Notes

pierrot s'écrase au sol

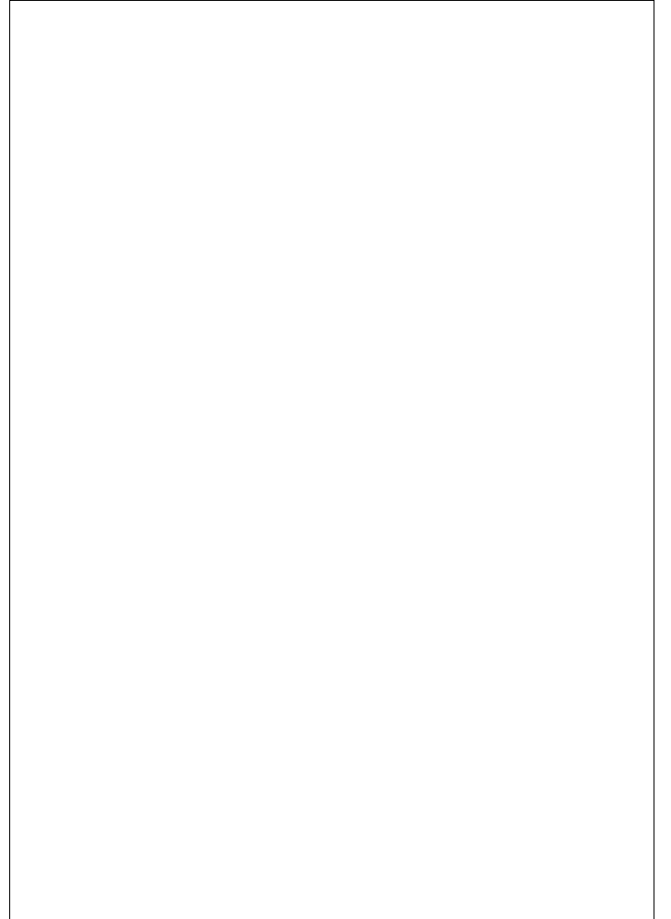

Scene	Duration	Panel	Duration
042	01:10	3	00:10

Scene	Duration	Panel	Duration
042	01:10	4	00:10

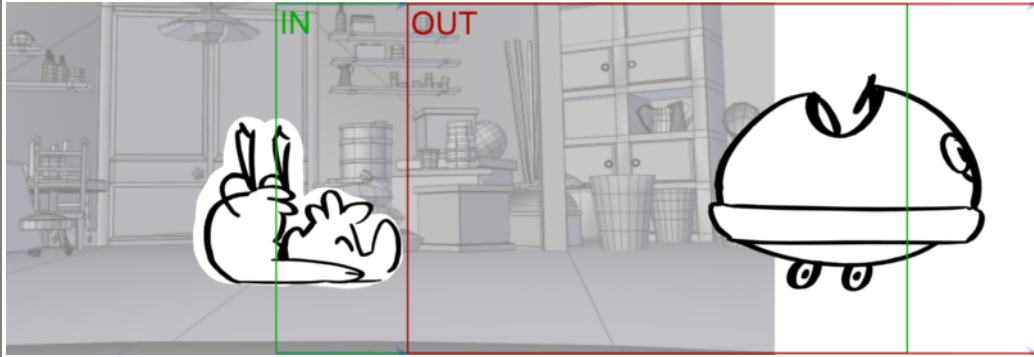

Action Notes

la voiture continue son chemin



Scene	Duration	Panel	Duration
043	01:11	1	00:12

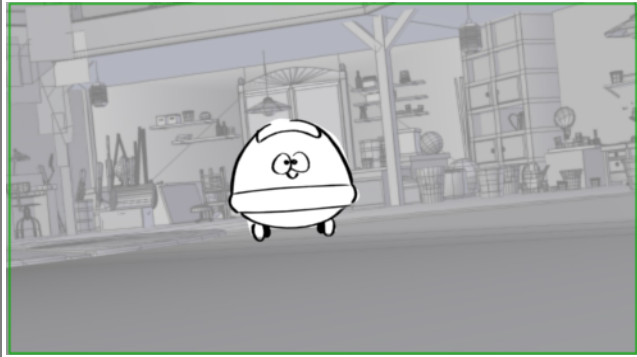

Scene	Duration	Panel	Duration
043	01:11	2	00:12

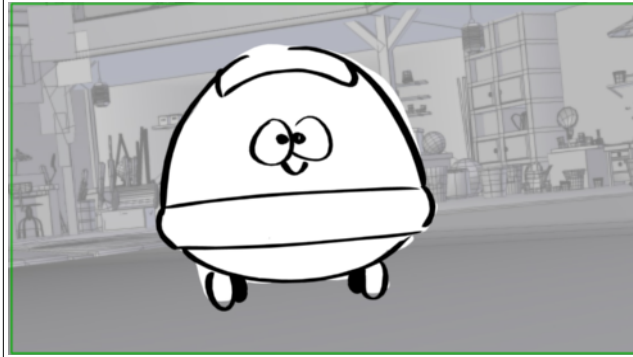

Scene	Duration	Panel	Duration
043	01:11	3	00:12

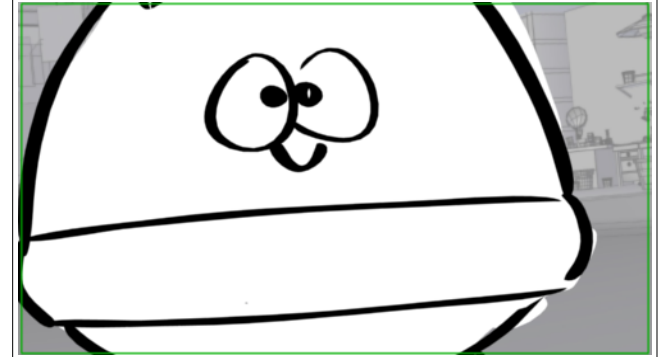

Action Notes
POV Calimero et Pierrot



Scene	Duration	Panel	Duration
044	03:10	1	00:07

NO PANEL

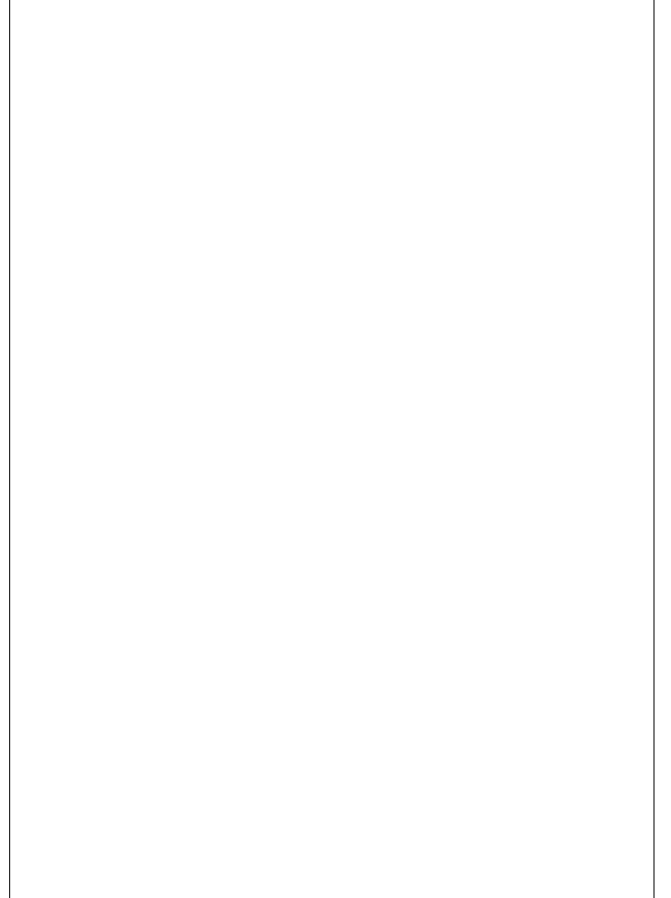
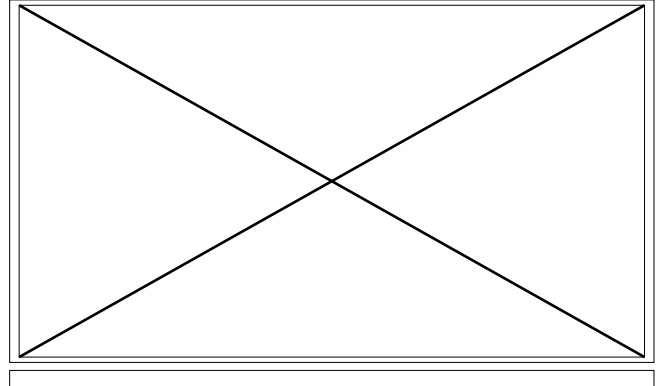



Scene	Duration	Panel	Duration
044	03:10	2	00:06

NO PANEL

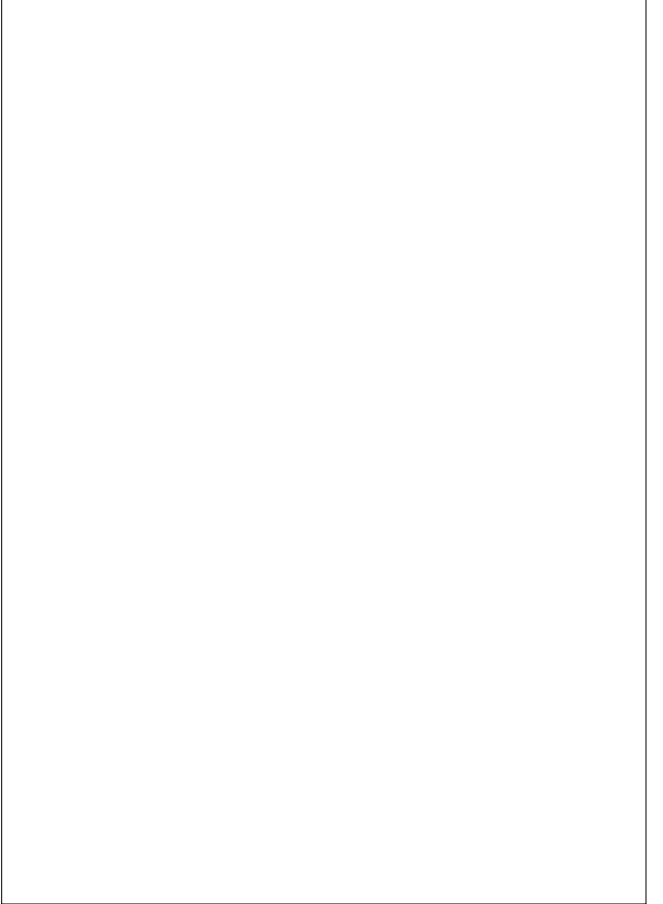
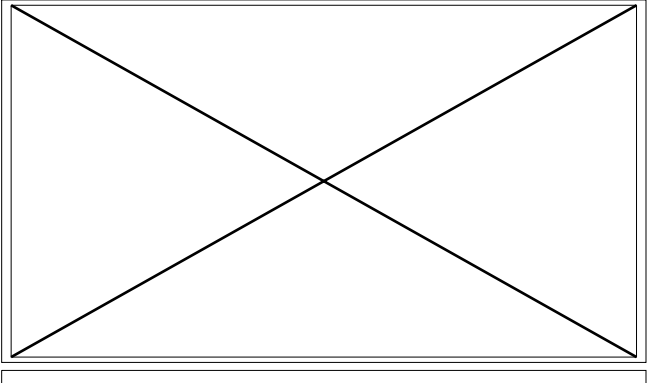



Scene	Duration	Panel	Duration
044	03:10	3	00:15

NO PANEL

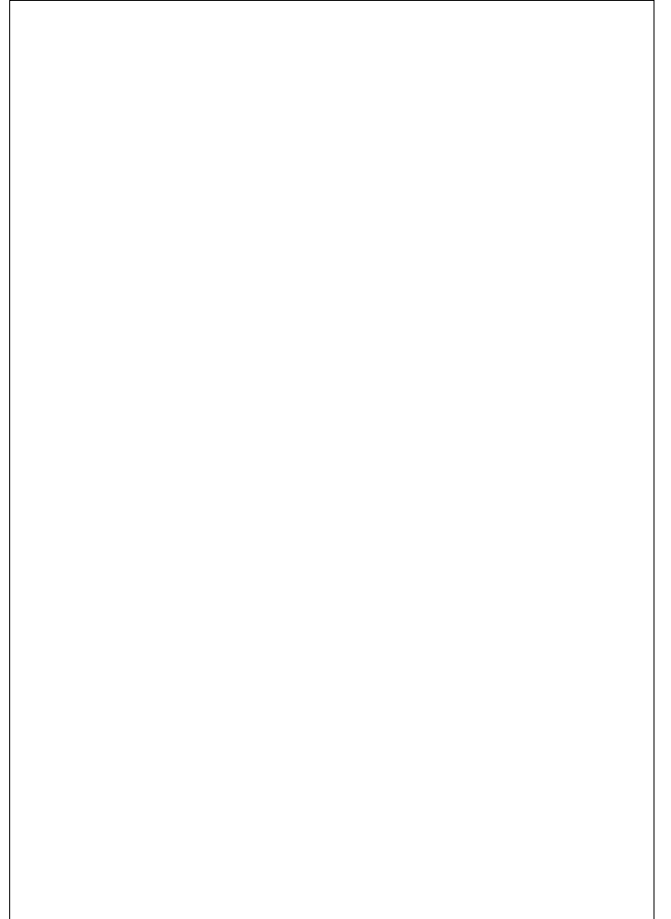
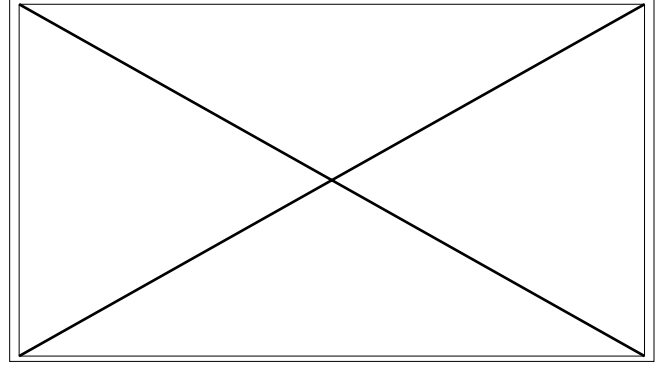
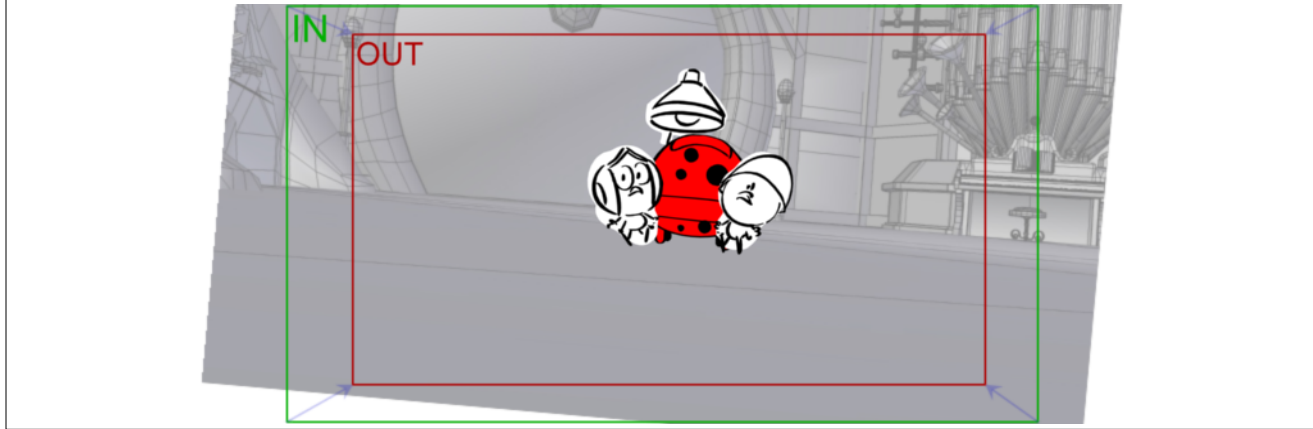



Scene	Duration	Panel	Duration
044	03:10	4	00:13

NO PANEL

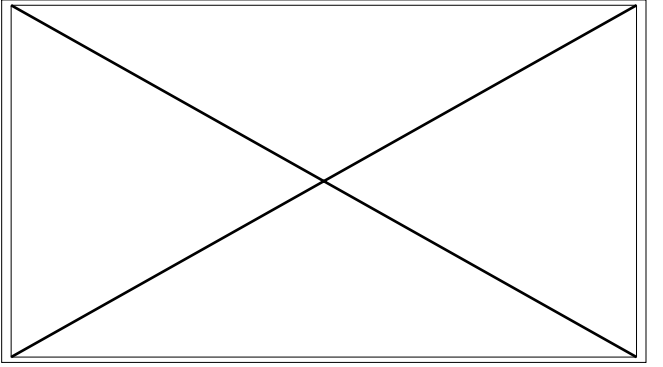
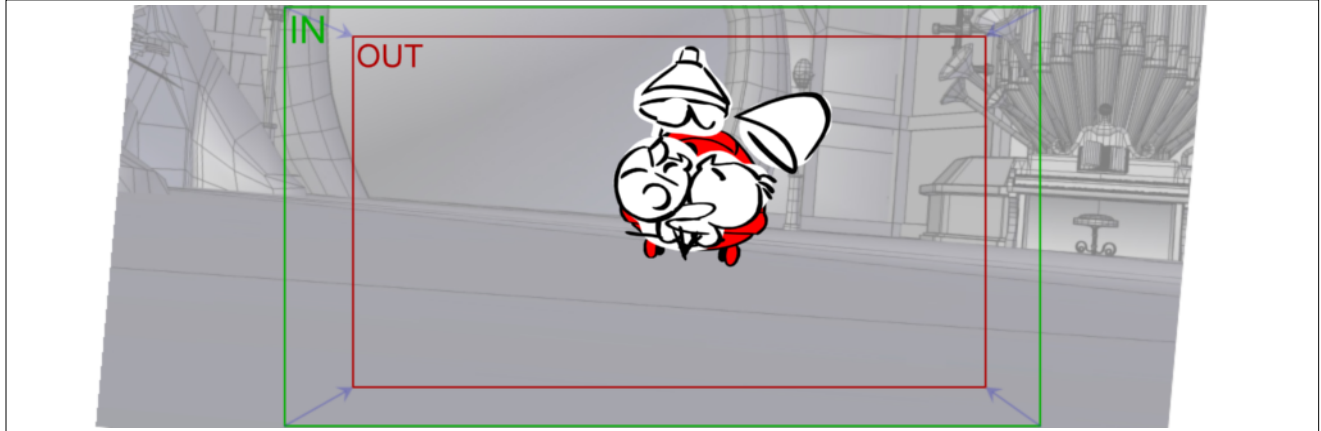

Action Notes

dans la panique les deux poussins se rentrent dedans

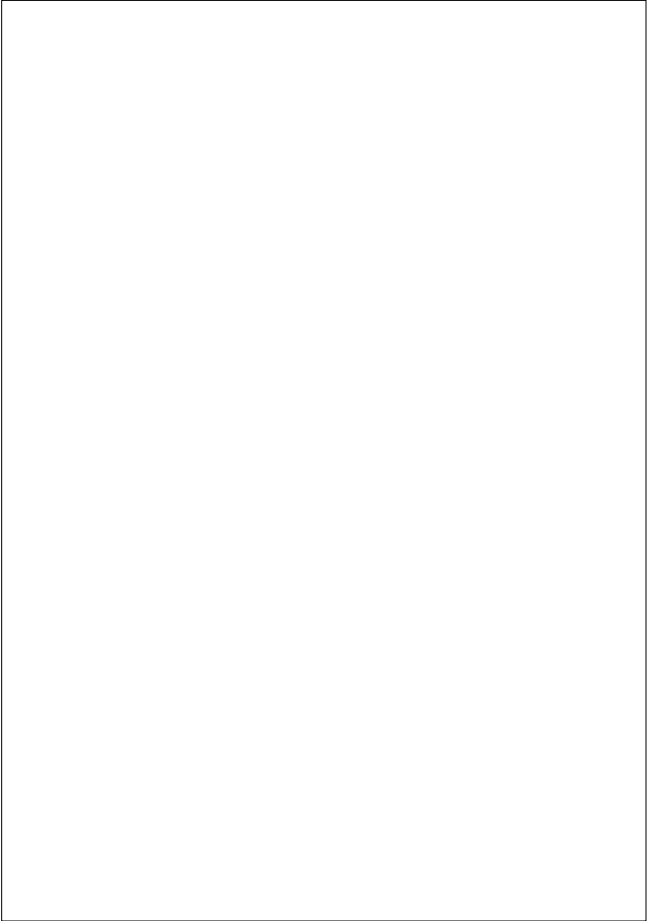



Scene	Duration	Panel	Duration
044	03:10	5	00:11

NO PANEL

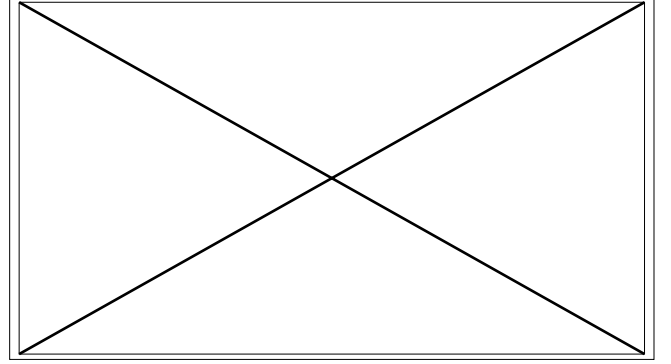
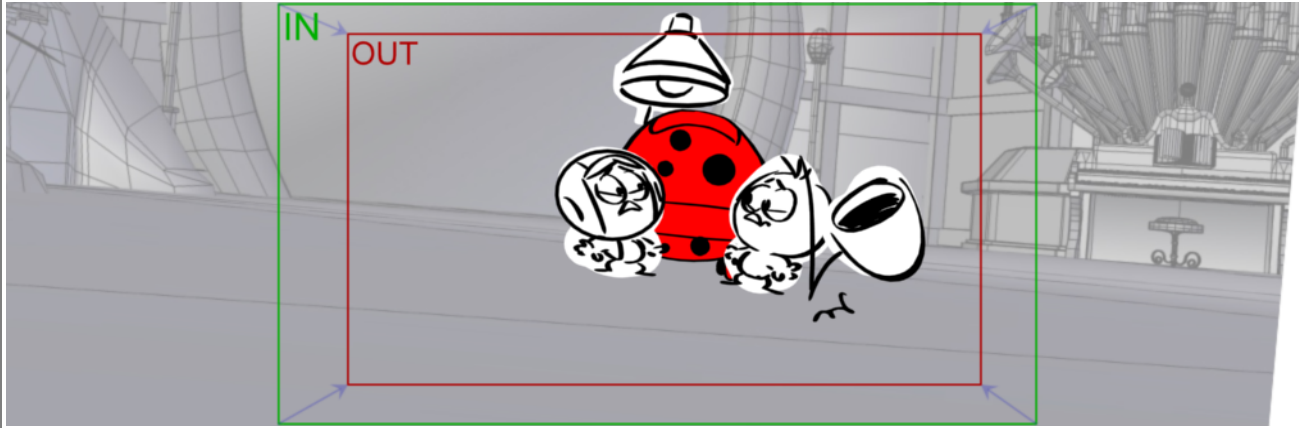

Action Notes

la coquille de calimero tombe à terre

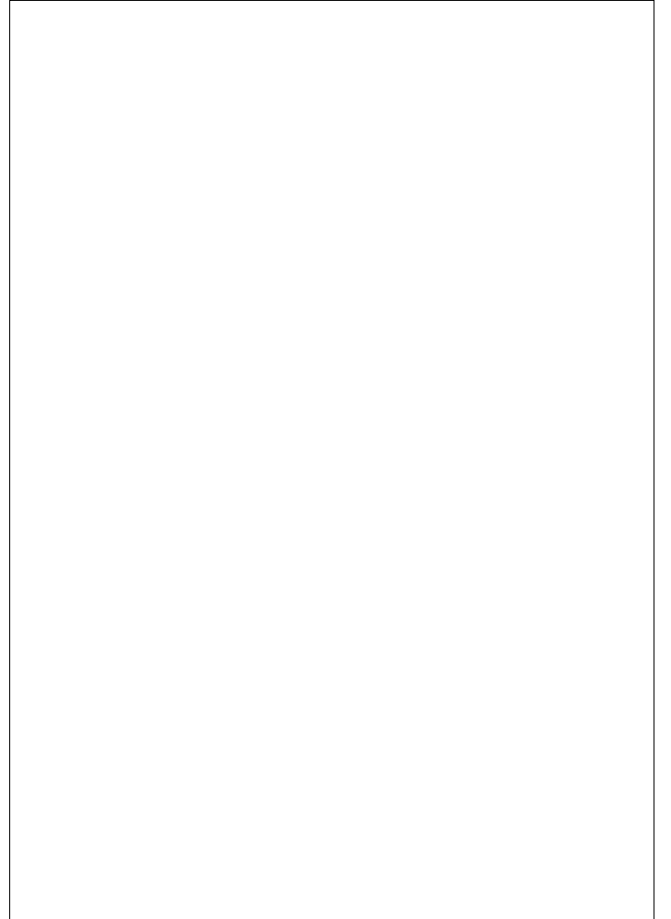



Scene	Duration	Panel	Duration
044	03:10	6	01:00

NO PANEL

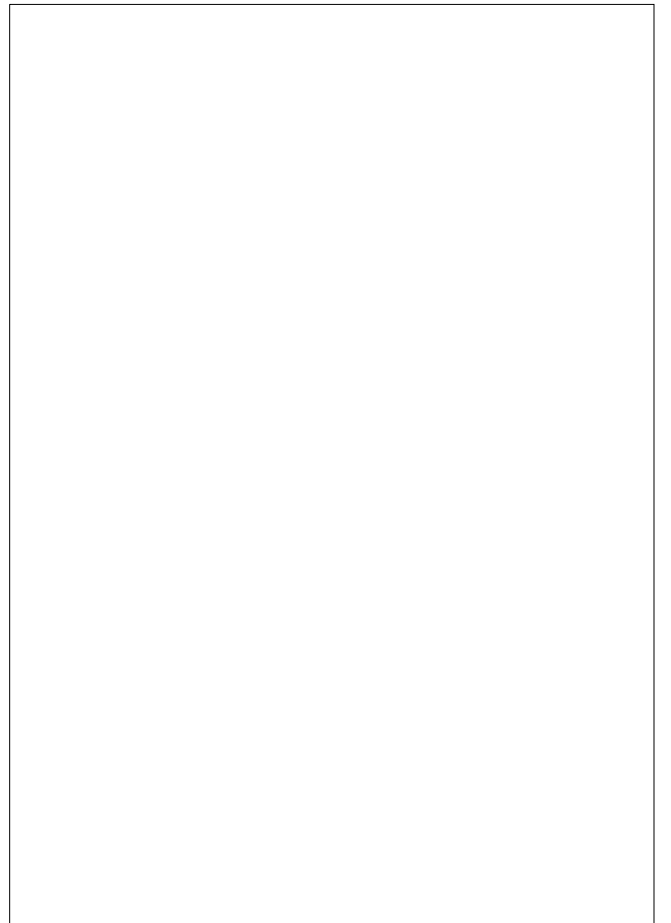
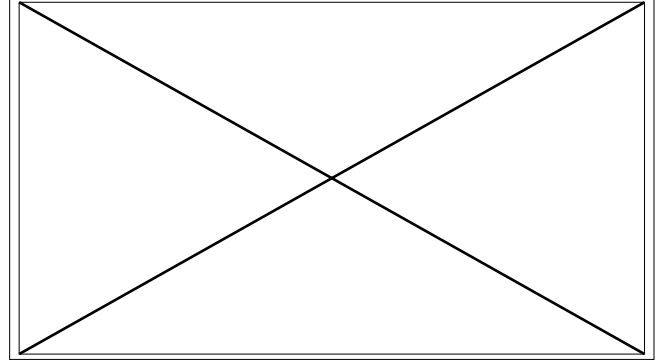
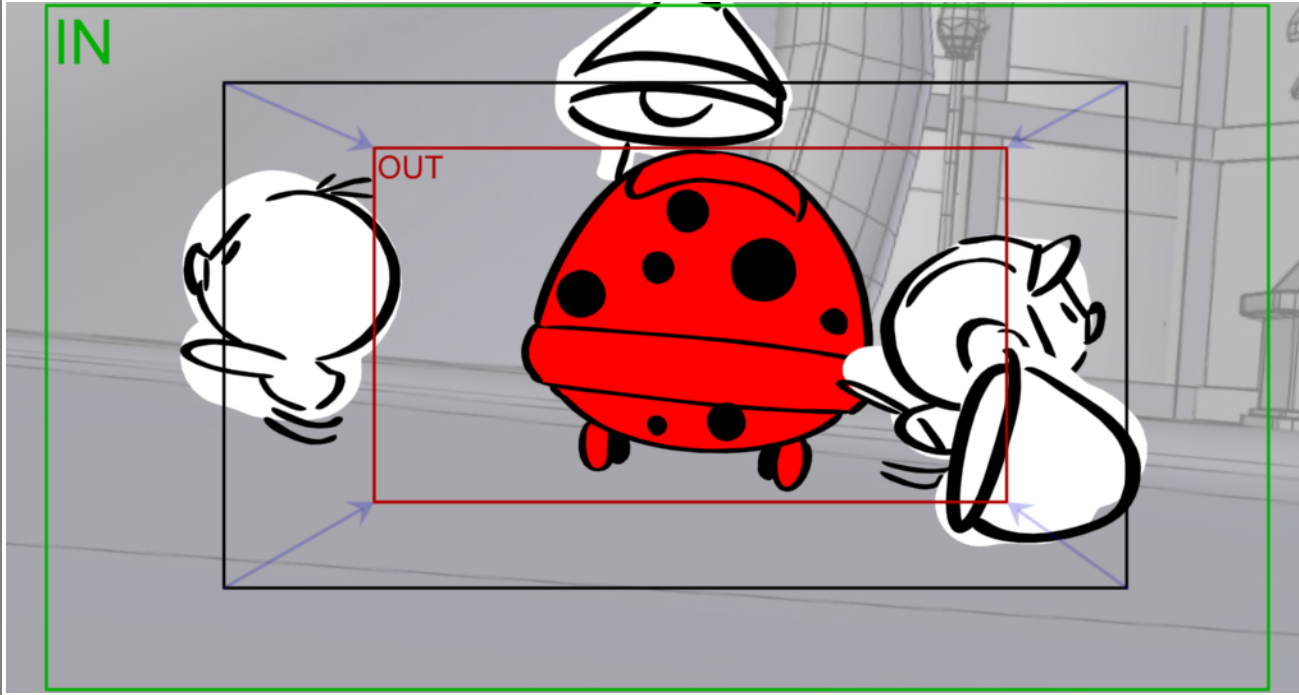



Scene	Duration	Panel	Duration
044	03:10	7	00:08

Scene	Duration	Panel	Duration
045	02:00	1	00:06

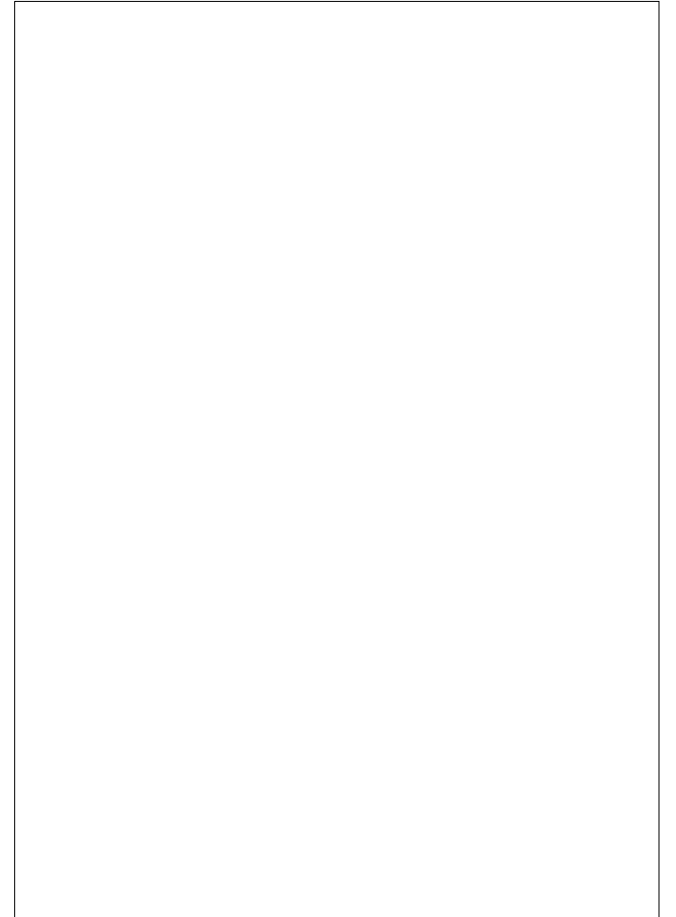
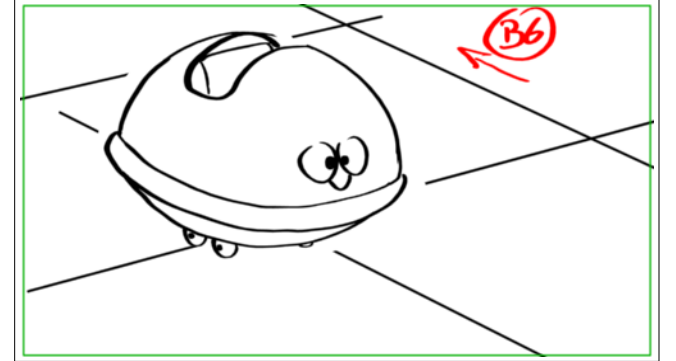
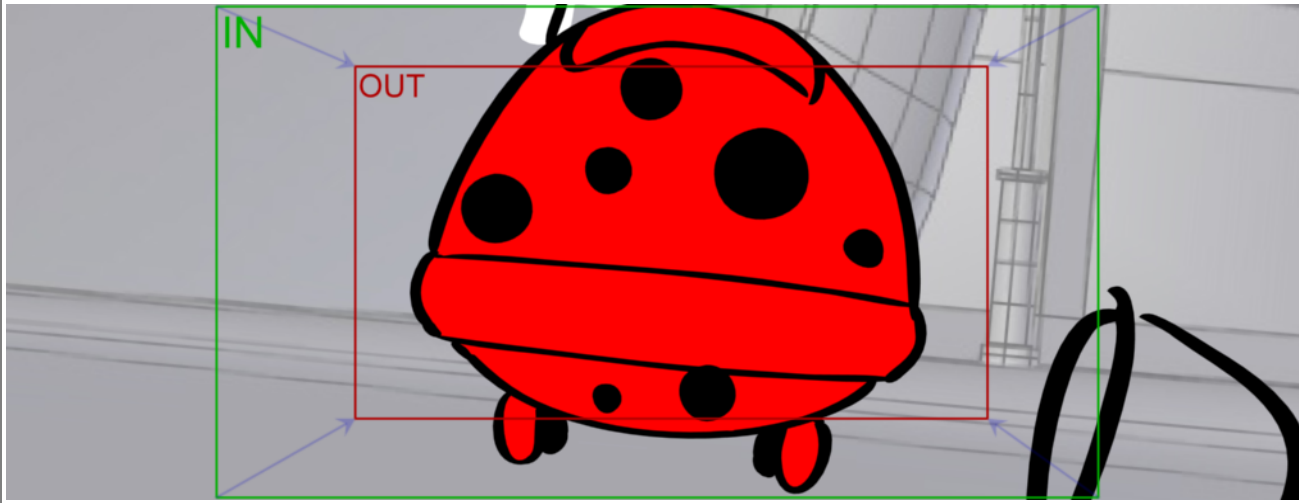

Scene	Duration	Panel	Duration
045	02:00	2	00:13

Scene	Duration	Panel	Duration
045	02:00	3	00:18

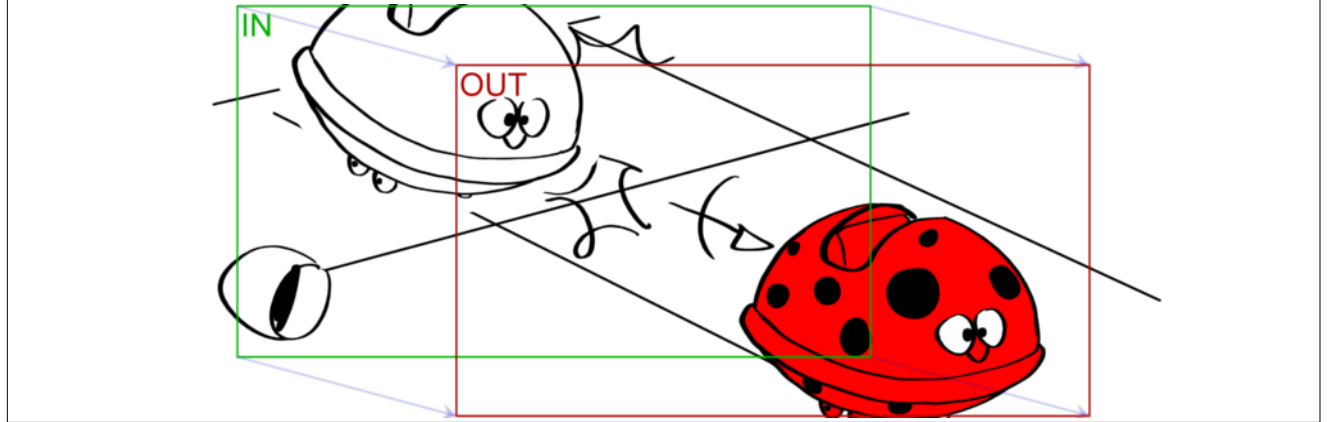
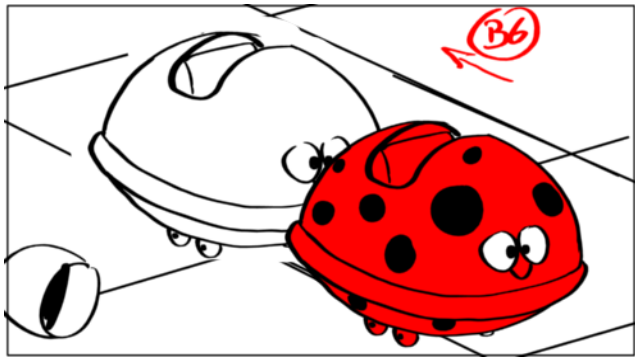

Action Notes

la voiture de pierrot tamponne la coccinelle qui était à l'arrêt
 PAN BG

Scene	Duration	Panel	Duration
045	02:00	4	00:13

Scene	Duration	Panel	Duration
046	01:24	1	00:06

Scene	Duration	Panel	Duration
046	01:24	2	00:07

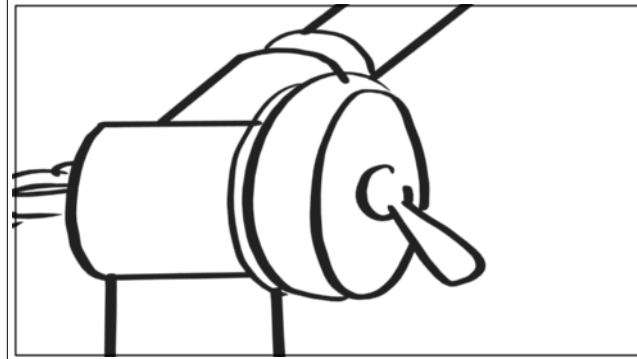
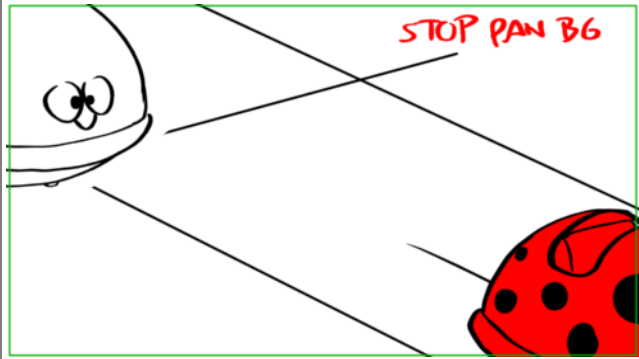

Action Notes

La coccinelle sort du champs

Action Notes

la coccinelle passe IN/ OUT à toute vitesse

Scene	Duration	Panel	Duration
046	01:24	3	00:08



Scene	Duration	Panel	Duration
046	01:24	4	00:11

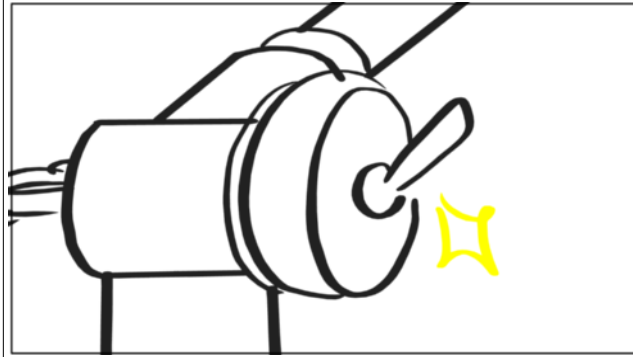

Action Notes
 En passant elle déclenche
 l'interrupteur du colorimoitout

Scene	Duration	Panel	Duration
046	01:24	5	00:09

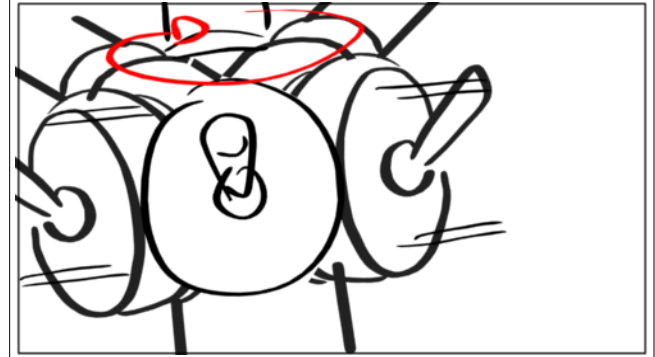

Action Notes
 qui se met à tourner sur place

Scene	Duration	Panel	Duration
046	01:24	6	00:08

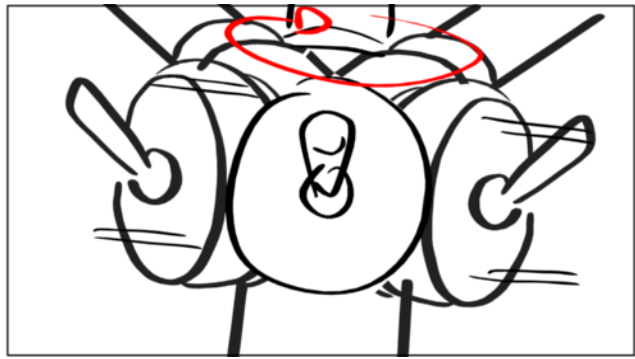

Scene	Duration	Panel	Duration
047	04:16	1	00:11

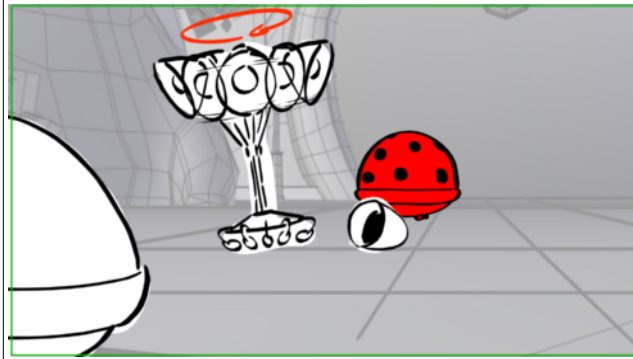

Scene	Duration	Panel	Duration
047	04:16	2	00:11



Action Notes

le colorimoitout tangué en tournant sur lui même. la coccinelle fini sa course en heurtant la porte des inventions

Scene	Duration	Panel	Duration
047	04:16	3	00:11

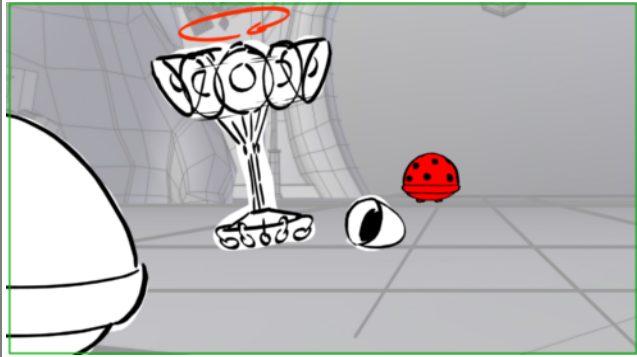

Scene	Duration	Panel	Duration
047	04:16	4	00:11

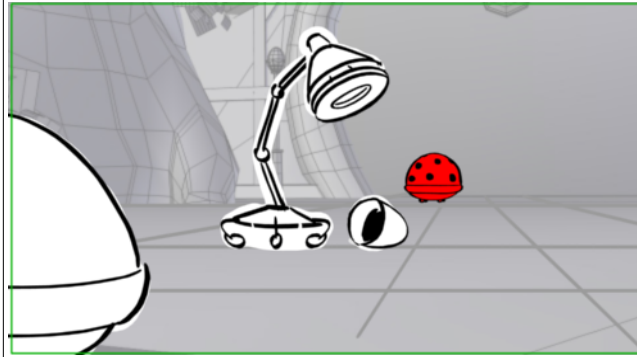

Action Notes
le colorimoitout s'arrête de tourner

Scene	Duration	Panel	Duration
047	04:16	5	00:24

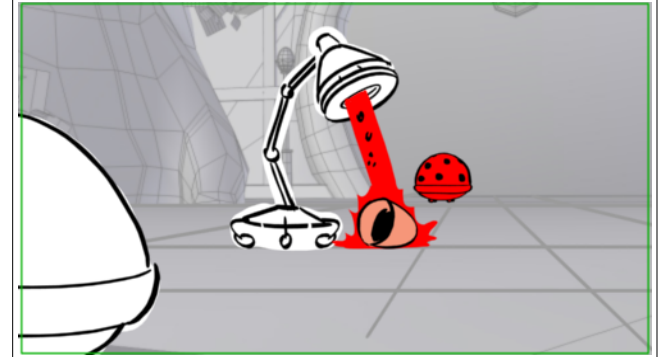

Action Notes
et balance un rayon en direction de la coquille

Scene	Duration	Panel	Duration
047	04:16	6	00:13

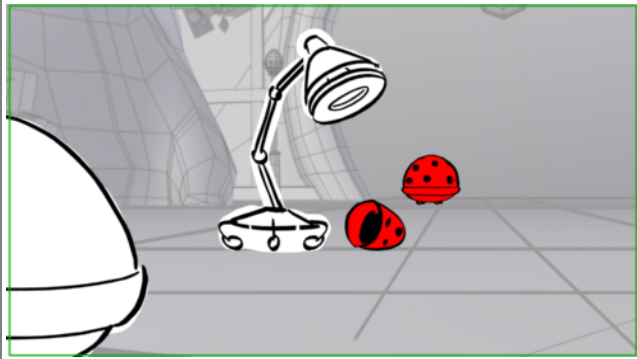

Scene	Duration	Panel	Duration
047	04:16	7	00:22

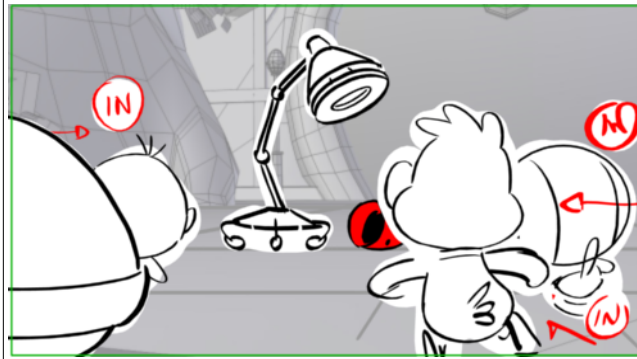

Scene	Duration	Panel	Duration
047	04:16	8	00:13

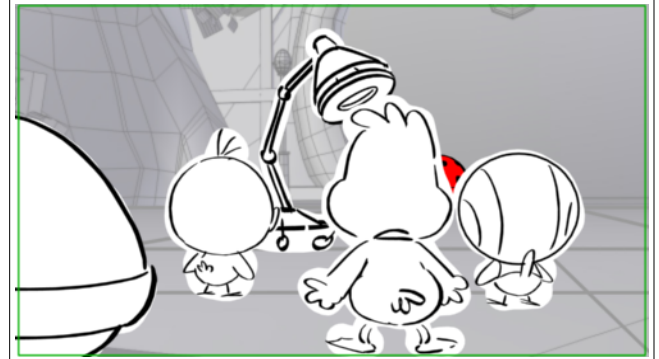

Scene	Duration	Panel	Duration
048	02:19	1	00:10



Scene	Duration	Panel	Duration
048	02:19	2	00:08

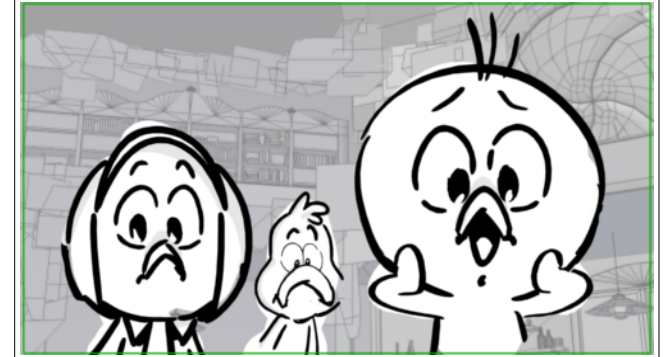

Scene	Duration	Panel	Duration
048	02:19	3	02:01

**Dialogue**

19. CALIMERO (mécontent, tête nue)
Ma coquille !



Scene	Duration	Panel	Duration
049	02:01	1	00:20

Scene	Duration	Panel	Duration
049	02:01	2	00:16

Scene	Duration	Panel	Duration
049	02:01	3	00:15

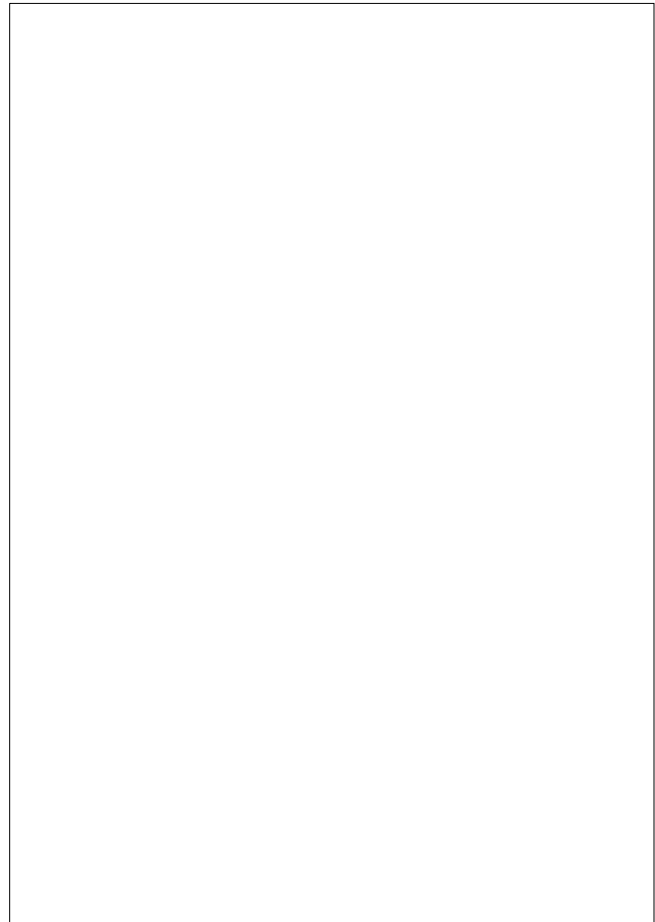
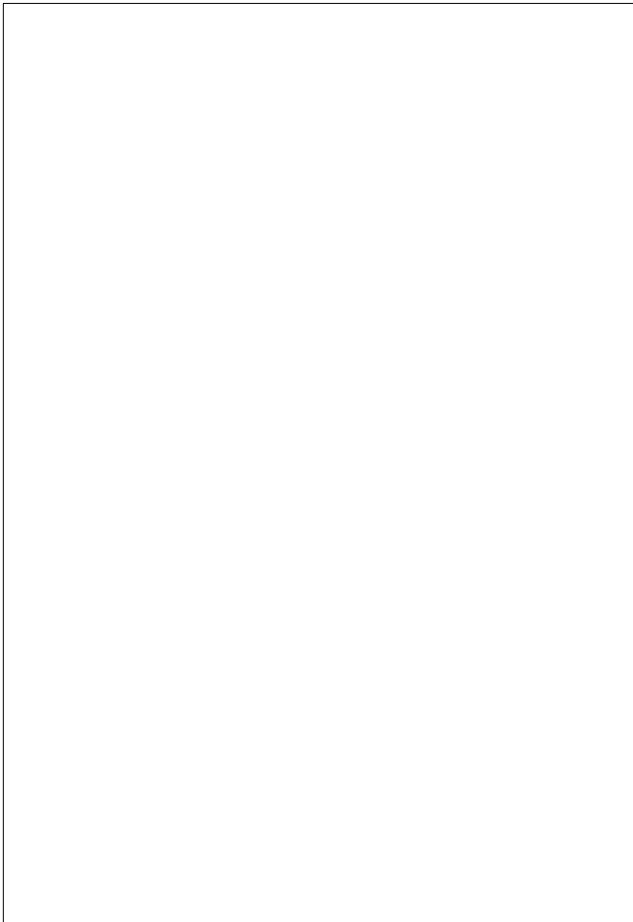
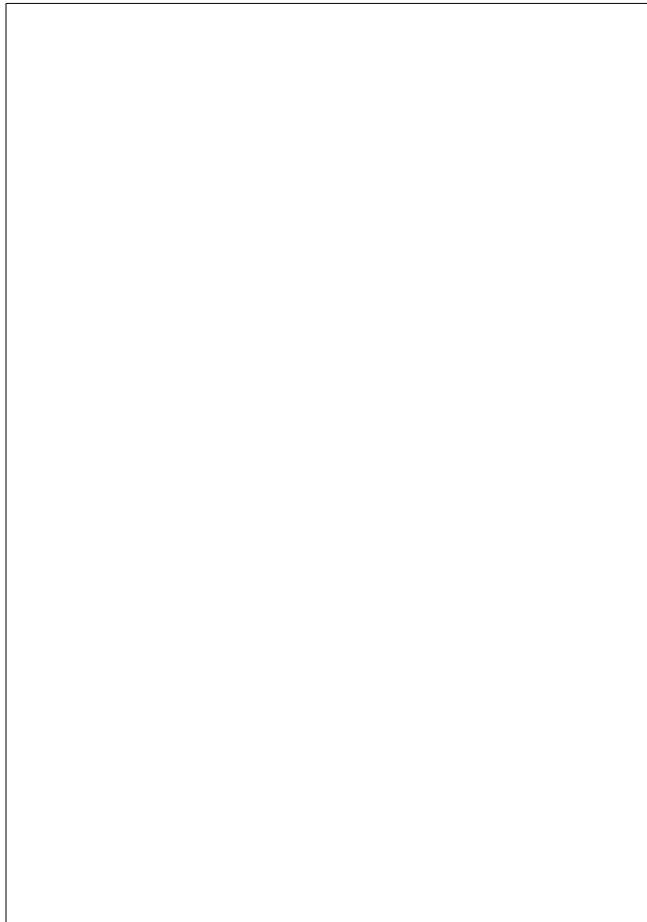
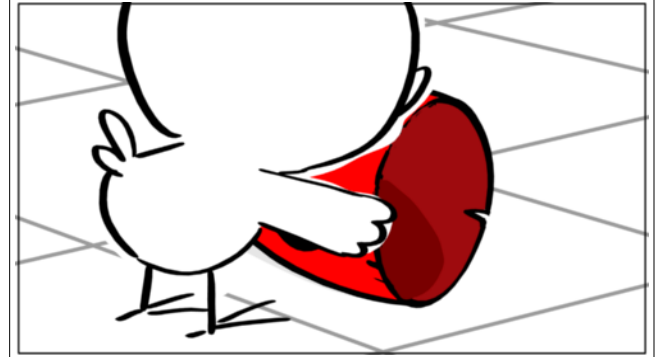
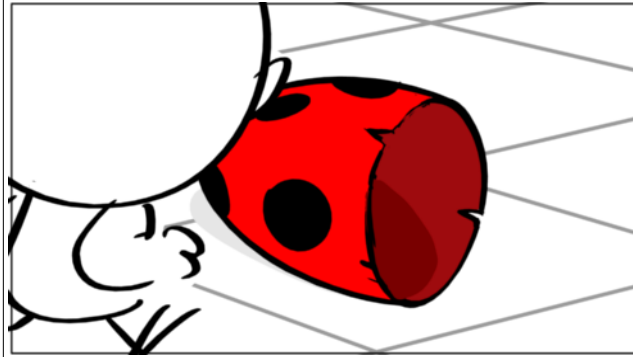
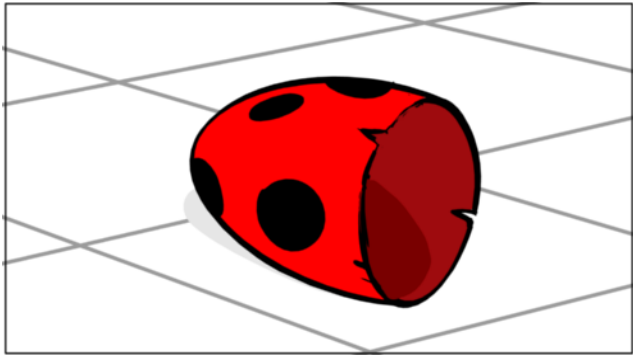

Scene	Duration	Panel	Duration
050	05:21	1	00:11

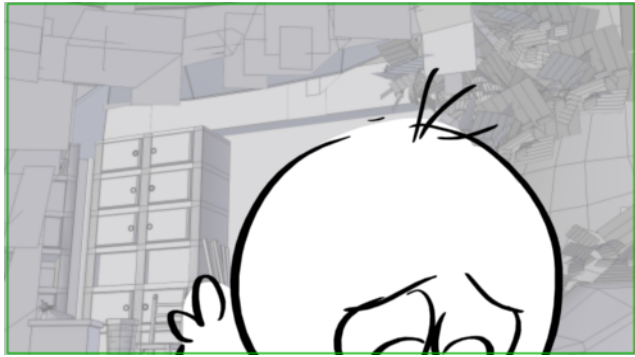
**Dialogue**

20. CALIMERO (tête nue, sous le choc)
Oh non,

Scene	Duration	Panel	Duration
050	05:21	2	01:00

**Dialogue**

20. CALIMERO (tête nue, sous le choc)
ma ma ma

Scene	Duration	Panel	Duration
050	05:21	3	00:09

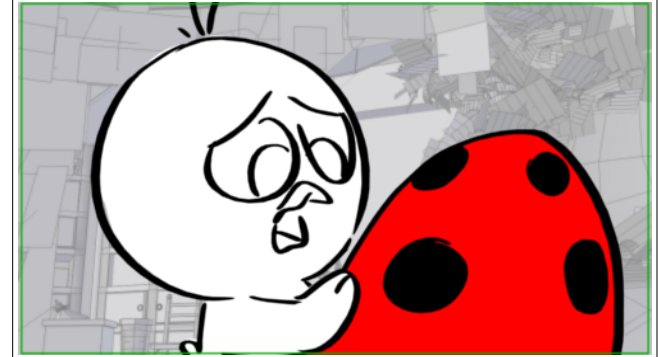
**Dialogue**

20. CALIMERO (tête nue, sous le choc)
ma coquille !

Scene	Duration	Panel	Duration
050	05:21	4	00:08

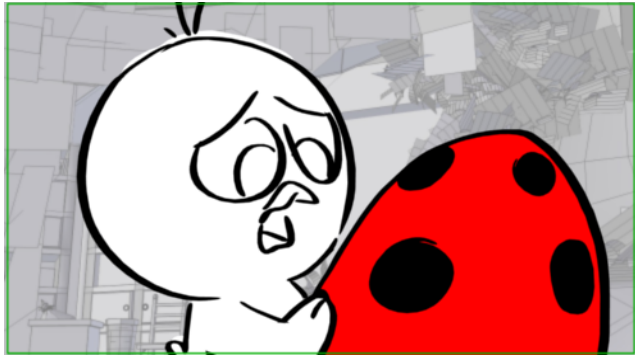
**Dialogue**

20. CALIMERO (tête nue, sous le choc)
ma coquille !

Scene	Duration	Panel	Duration
050	05:21	5	00:09

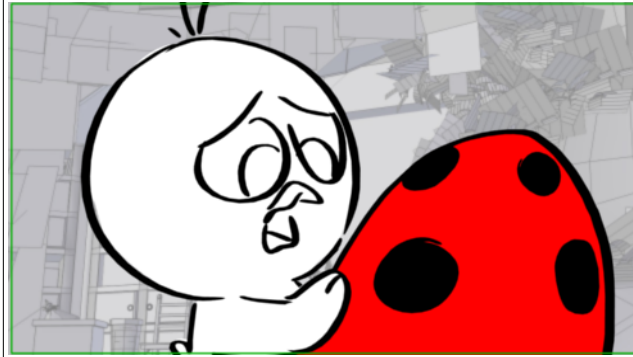
**Dialogue**

20. CALIMERO (tête nue, sous le choc)
ma coquille !

Scene	Duration	Panel	Duration
050	05:21	6	01:01

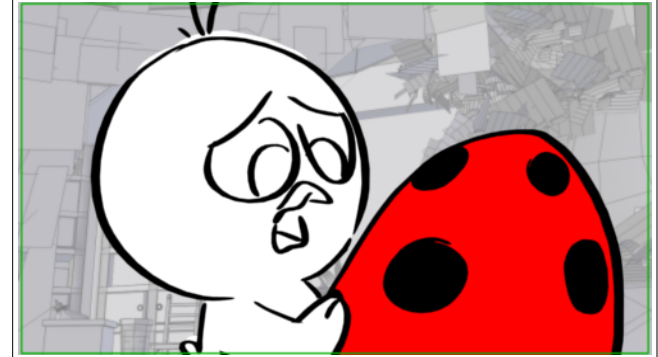
**Dialogue**

20. CALIMERO (tête nue, sous le choc)
coquille !

Scene	Duration	Panel	Duration
050	05:21	7	00:18



Scene	Duration	Panel	Duration
050	05:21	8	00:15



Scene	Duration	Panel	Duration
050	05:21	9	01:00



Dialogue

21. PIERROT (farceur, pointant du doigt la coquille)

< HAAAAHA >

Scene	Duration	Panel	Duration
051	19:21	1	02:01

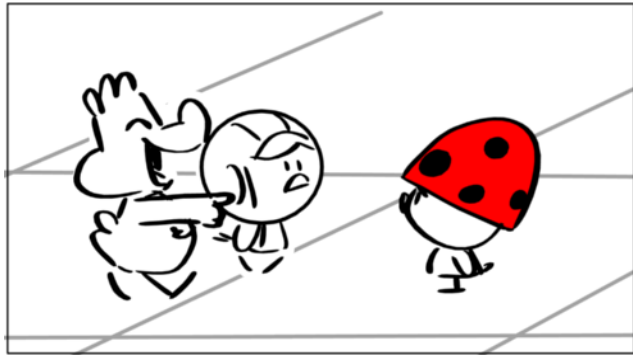
Dialogue

21. PIERROT (farceur, pointant du doigt la coquille)
 C'est toi qui vas faire la coccinelle, maintenant !

Scene	Duration	Panel	Duration
051	19:21	2	02:01

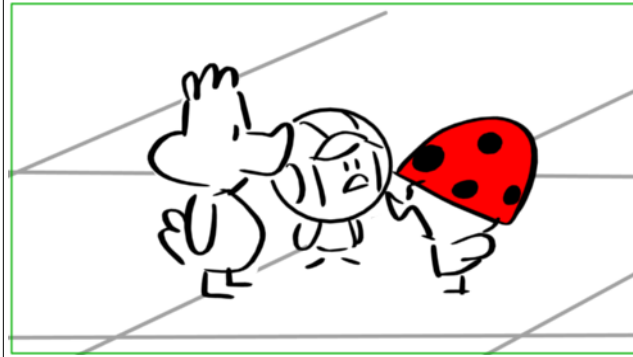
Dialogue

22. CALIMERO (tête nue, affecté)
 Ce n'est pas rigolo du tout Pierrot !

Scene	Duration	Panel	Duration
051	19:21	3	02:07

Dialogue

22. CALIMERO (tête nue, affecté)
 Je vais avoir l'air d'un clown !

Scene	Duration	Panel	Duration
051	19:21	4	01:22

NO PANEL

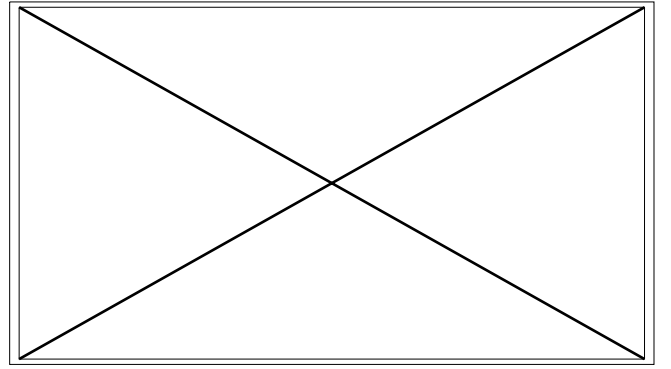
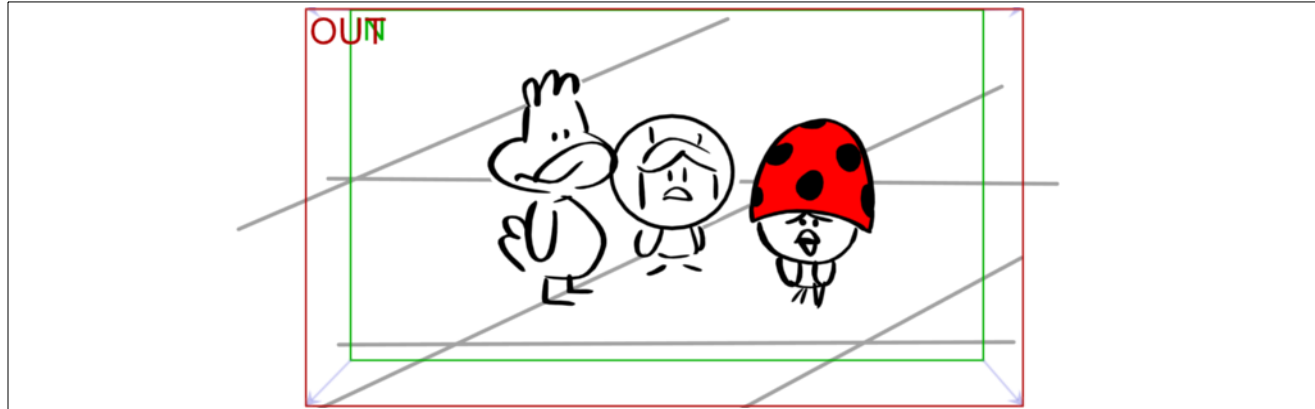

Dialogue
24. CALIMERO (déconfit)
C'est vraiment trop injuste !

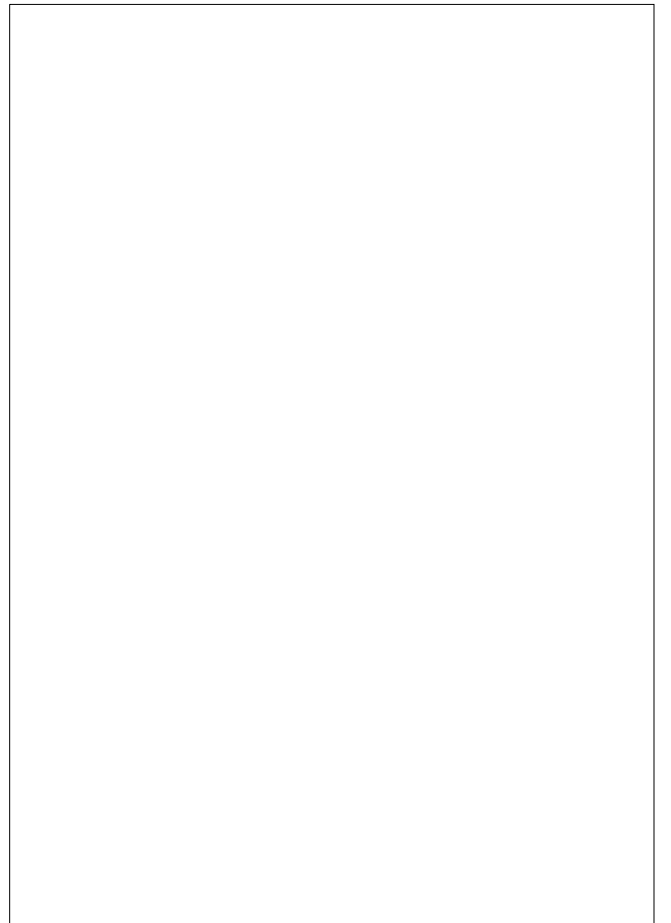

Scene	Duration	Panel	Duration
051	19:21	5	00:19

NO PANEL

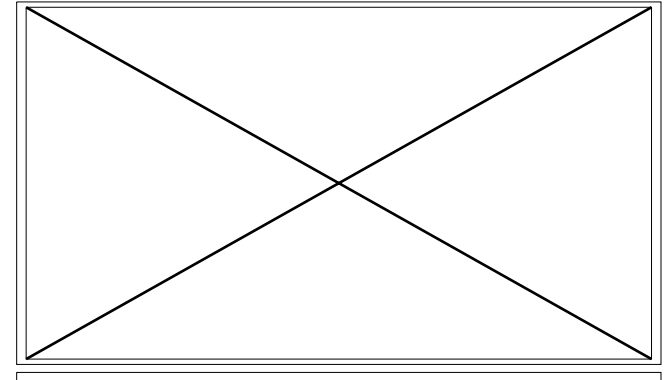

Dialogue

24. CALIMERO (déconfit)
C'est vraiment trop injuste !

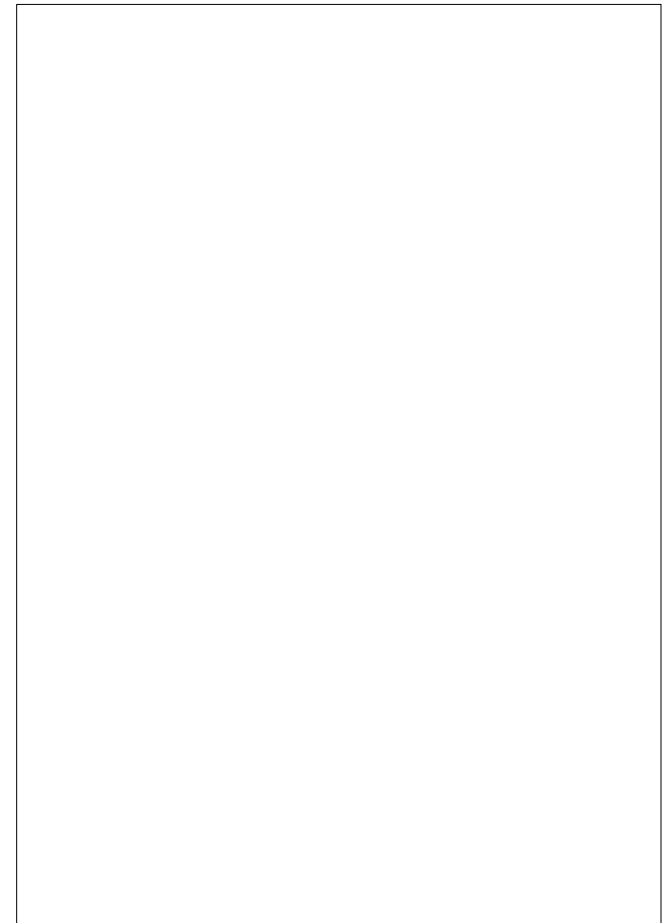

Scene	Duration	Panel	Duration
051	19:21	6	01:23

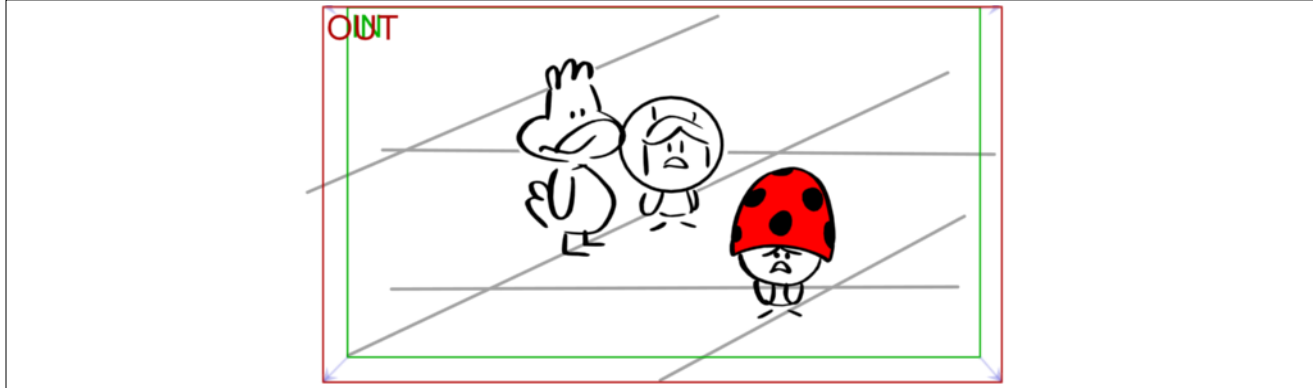

Dialogue
 24. CALIMERO (déconfit)
 C'est vraiment trop injuste !

Scene	Duration	Panel	Duration
051	19:21	7	01:01



Dialogue
 23. PIERROT (renfrogné)
 Si on peut plus rien dire maintenant!

Scene	Duration	Panel	Duration
051	19:21	8	01:15



Dialogue

25. VALERIANO (gêné, rassurant)
T'inquiète pas Caliméro,

Scene	Duration	Panel	Duration
051	19:21	9	03:12

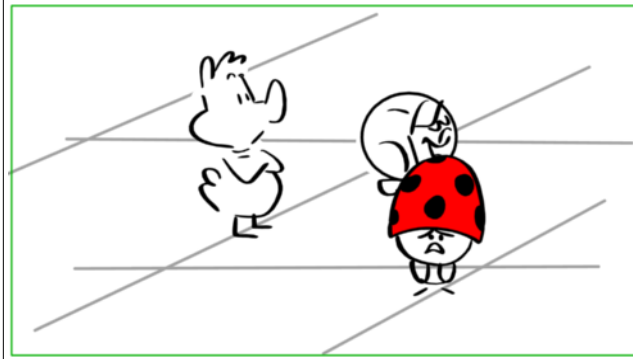

Dialogue

25. VALERIANO (gêné, rassurant)
on va repasser ta coquille dans le
Colorimoitout avec le filtre blanc !

Scene	Duration	Panel	Duration
051	19:21	10	01:07

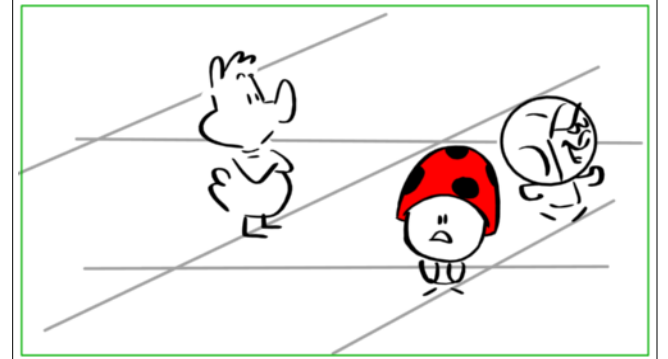

Dialogue

25. VALERIANO (gêné, rassurant)
Et elle redeviendra comme avant !

Scene	Duration	Panel	Duration
051	19:21	11	01:13

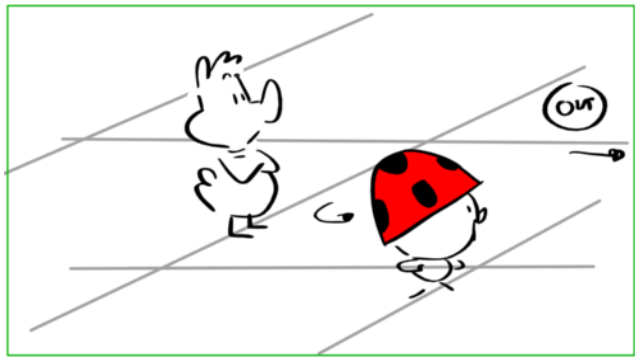

Dialogue
 26. CALIMERO (tête nue, plein d'espoir)
 Tu crois Valériano ?

Scene	Duration	Panel	Duration
052	05:11	1	00:11



Scene	Duration	Panel	Duration
052	05:11	2	01:00



Dialogue
 27. VALERIANO (listant les couleurs)
 Rouge, orange, jaune, vert, bleu,
 violet.

Scene	Duration	Panel	Duration
052	05:11	3	01:05

Scene	Duration	Panel	Duration
052	05:11	4	00:24

Scene	Duration	Panel	Duration
052	05:11	5	00:10

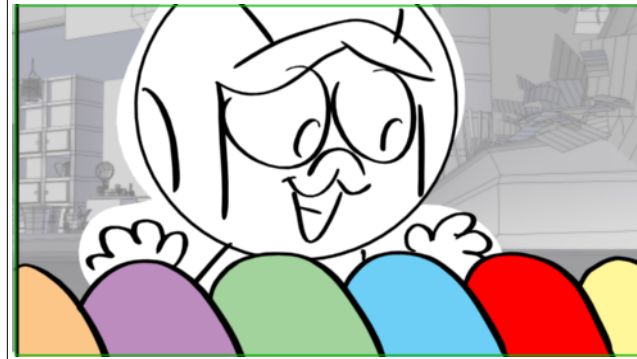
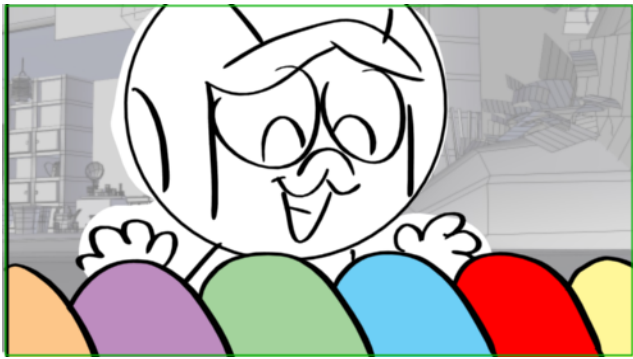

Dialogue
 27. VALERIANO (listant les couleurs)
 Rouge, orange, jaune, vert, bleu,
 violet.

Dialogue
 27. VALERIANO (listant les couleurs)
 Rouge, orange, jaune, vert, bleu,
 violet.

Scene	Duration	Panel	Duration
052	05:11	6	00:11

Scene	Duration	Panel	Duration
052	05:11	7	00:13

Scene	Duration	Panel	Duration
052	05:11	8	00:12



Dialogue
 PICK UP VALERIANO
 Ho!Ho!

Dialogue
 PICK UP VALERIANO
 Ho!Ho!

Dialogue
 PICK UP VALERIANO
 Ho!Ho!

Scene	Duration	Panel	Duration
053	12:09	1	00:17

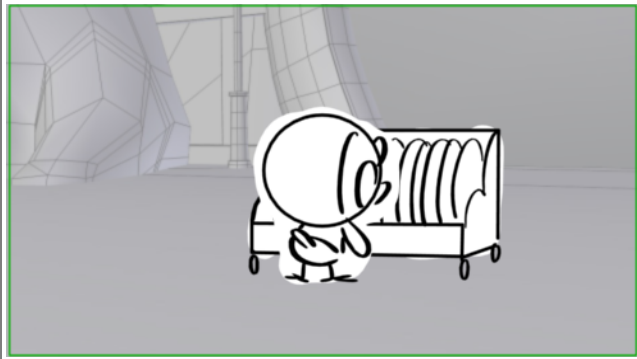

Dialogue
 27. VALERIANO (listant les couleurs)
 Pas de blanc!

Scene	Duration	Panel	Duration
053	12:09	2	01:00



Dialogue
 27. VALERIANO (listant les couleurs)
 Pas de blanc!

Scene	Duration	Panel	Duration
053	12:09	3	02:00

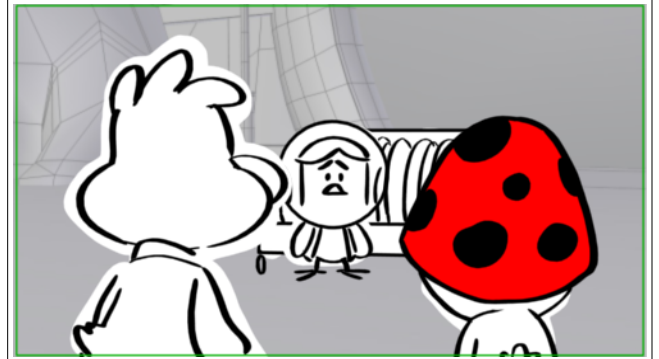

Dialogue
 28. CALIMERO (la coquille maintenant sur
 la tête, dépité)
 Oh non !

Scene	Duration	Panel	Duration
053	12:09	4	01:00

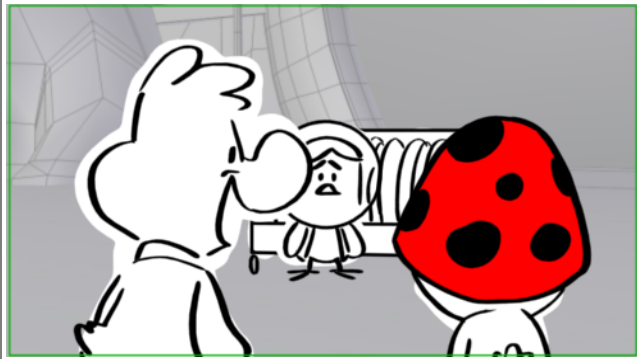

Dialogue
 29. PIERROT MODIF
 Eh Calimero!

Scene	Duration	Panel	Duration
053	12:09	5	01:00

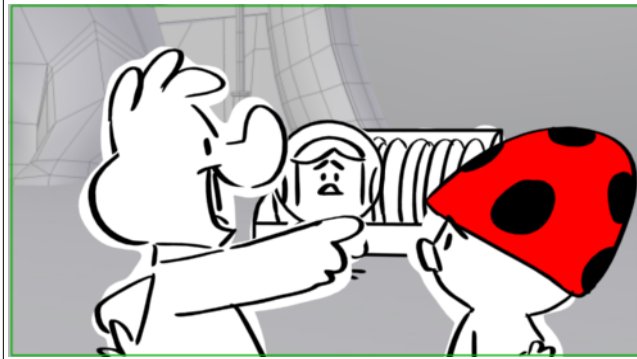

Dialogue
 29. PIERROT MODIF
 Ta coquille..

Scene	Duration	Panel	Duration
053	12:09	6	02:08

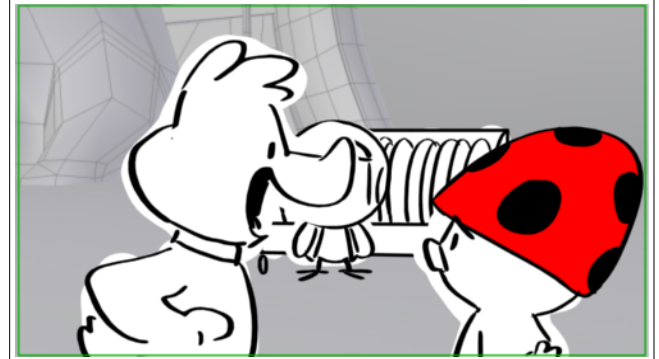

Dialogue
 29. PIERROT MODIF
 ..On pourrait la nettoyer!

Scene	Duration	Panel	Duration
053	12:09	7	02:15

Scene	Duration	Panel	Duration
053	12:09	8	01:19

Scene	Duration	Panel	Duration
054	05:13	1	00:06

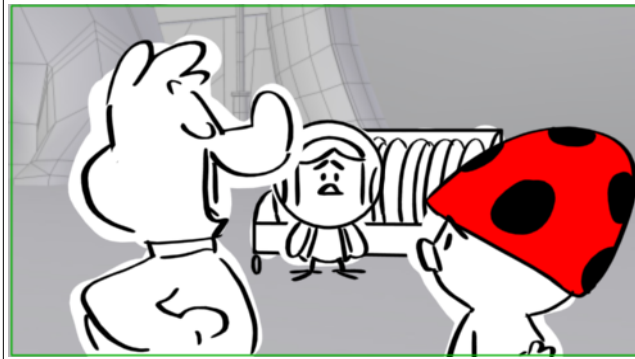
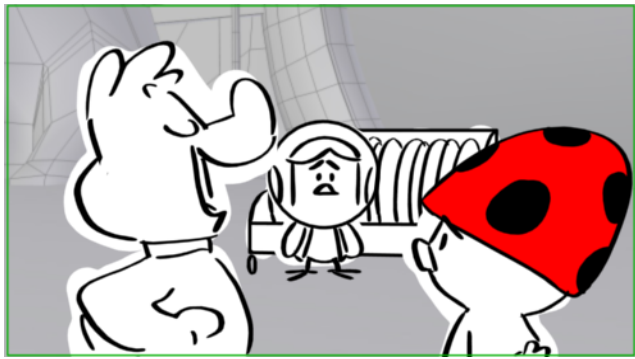

Dialogue

29. PIERROT MODIF

Au supermarché de mon papa, y a tout plein de produits pour enlever la peinture!

Dialogue

29. PIERROT MODIF

Au supermarché de mon papa, y a tout plein de produits pour enlever la peinture!

Dialogue

30. CALIMERO (reprenant espoir)

Mais oui!

Scene	Duration	Panel	Duration
054	05:13	2	00:19



Dialogue
 30. CALIMERO (reprenant espoir)
 Mais oui!

Scene	Duration	Panel	Duration
054	05:13	3	00:07



Dialogue
 30. CALIMERO (reprenant espoir)
 Tu as raison Pierrot!

Scene	Duration	Panel	Duration
054	05:13	4	01:00



Dialogue
 30. CALIMERO (reprenant espoir)
 Tu as raison Pierrot!



Scene	Duration	Panel	Duration
054	05:13	5	01:00

Scene	Duration	Panel	Duration
054	05:13	6	00:06

Scene	Duration	Panel	Duration
054	05:13	7	01:00



Dialogue
SFX Porte de l'atelier

Scene	Duration	Panel	Duration
054	05:13	8	01:00



Scene	Duration	Panel	Duration
055	01:11	1	00:11

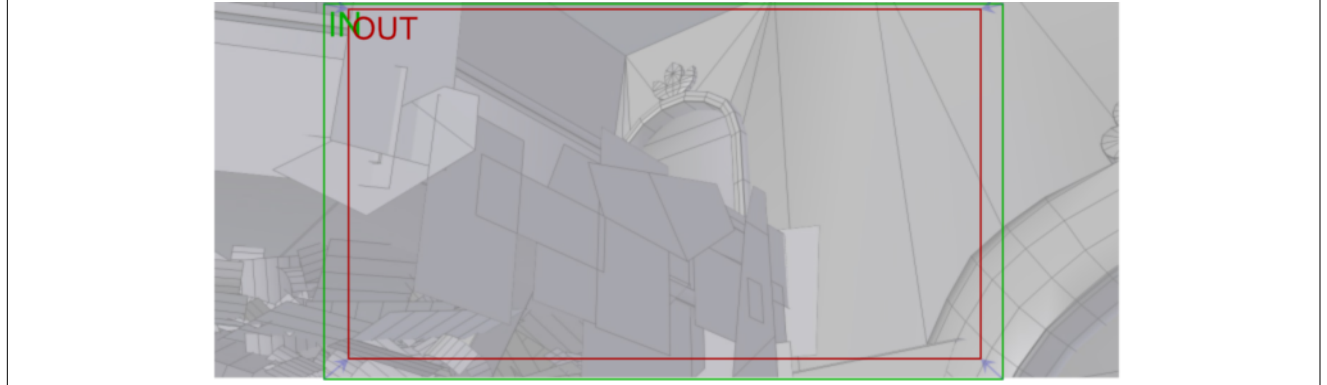

Action Notes

POV CALIMERO

La porte de l'atelier s'ouvre

Scene	Duration	Panel	Duration
055	01:11	2	01:00

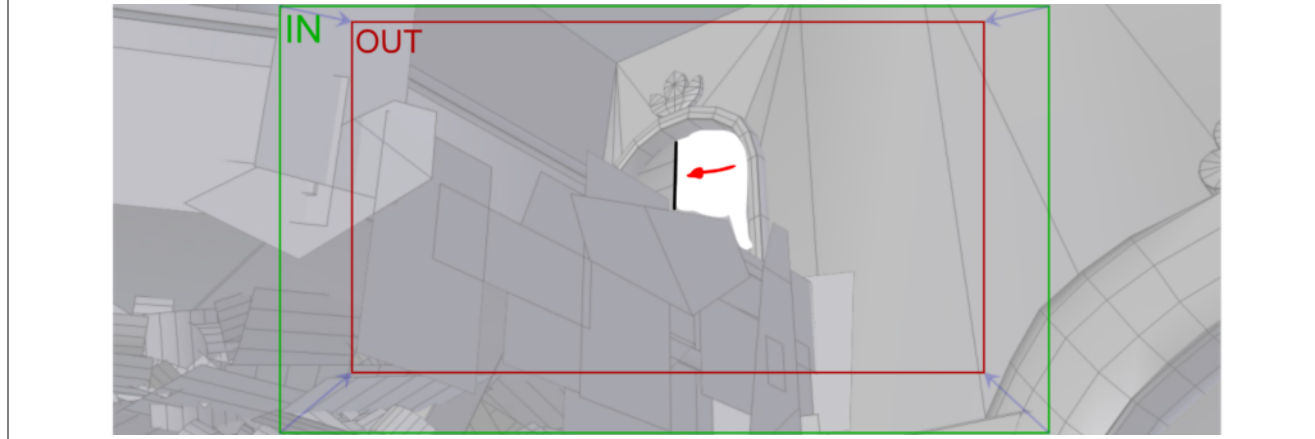

Scene	Duration	Panel	Duration
056	04:04	1	02:22

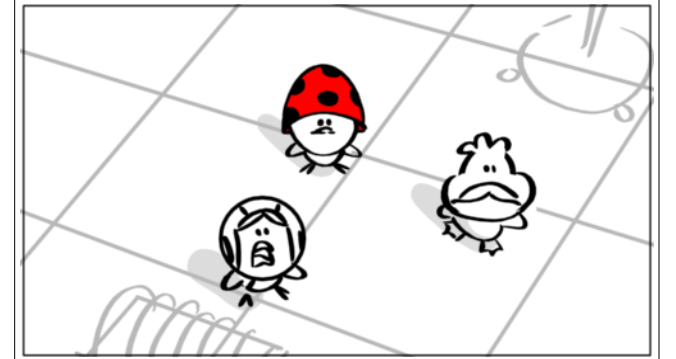

Dialogue

31. VALERIANO (tendant en l'air un doigt)
 Heu, les copains? Je crois qu'il y a Priscilla qui arrive?

Scene	Duration	Panel	Duration
056	04:04	2	01:07

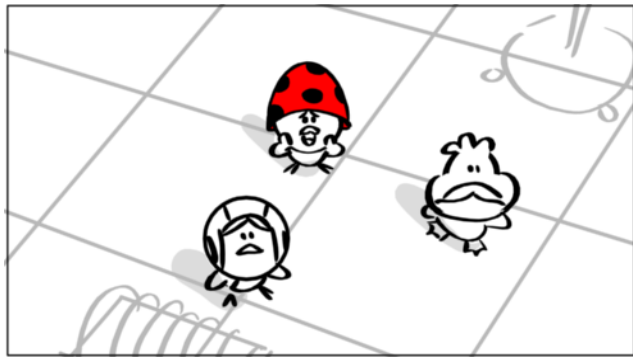

Dialogue
 32. CALIMERO
 Oh non ! Je ne veux pas qu'elle me voit
 comme ça ?

Scene	Duration	Panel	Duration
057	11:20	1	02:01



Scene	Duration	Panel	Duration
057	11:20	2	01:04





Scene	Duration	Panel	Duration
057	11:20	3	01:15

Scene	Duration	Panel	Duration
057	11:20	4	01:17

Scene	Duration	Panel	Duration
057	11:20	5	02:00

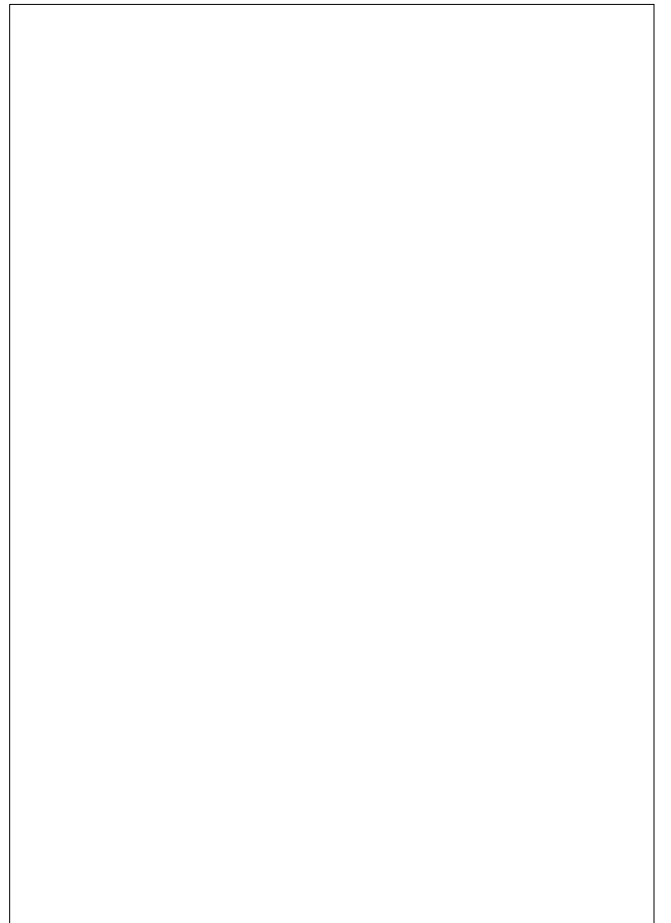
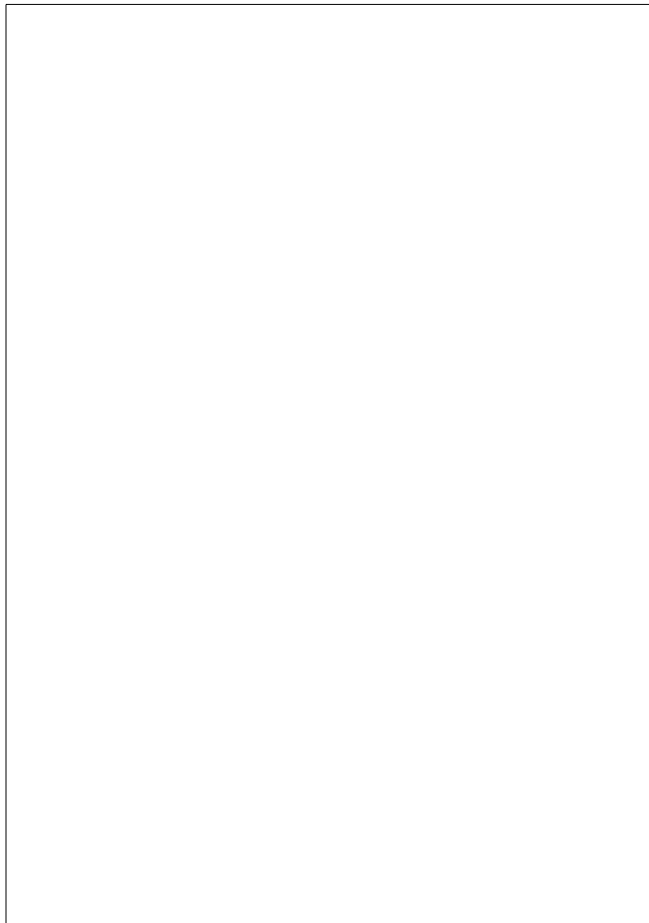



Scene	Duration	Panel	Duration
057	11:20	6	01:06

Scene	Duration	Panel	Duration
057	11:20	7	00:20

Scene	Duration	Panel	Duration
057	11:20	8	00:20

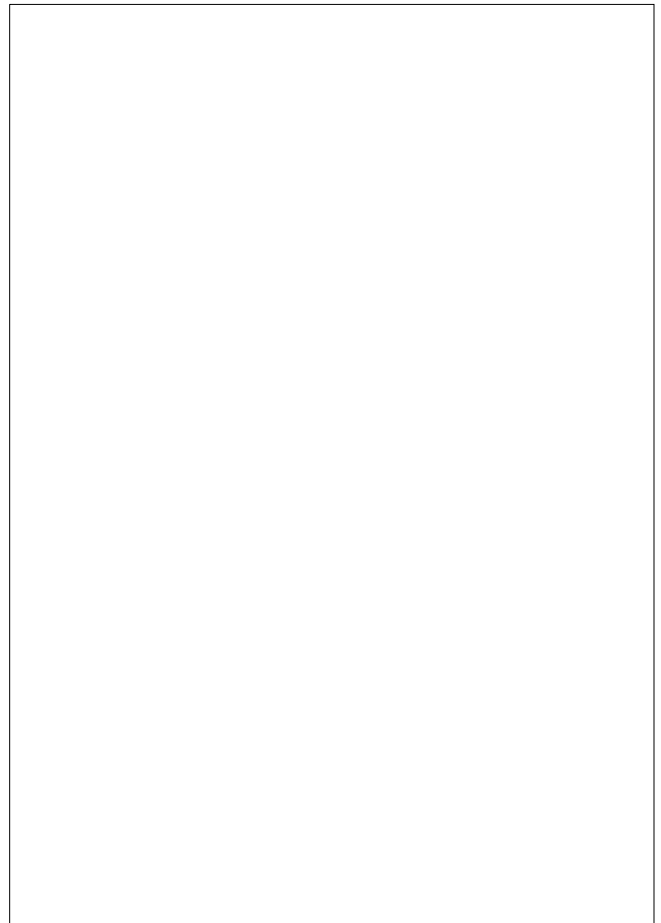
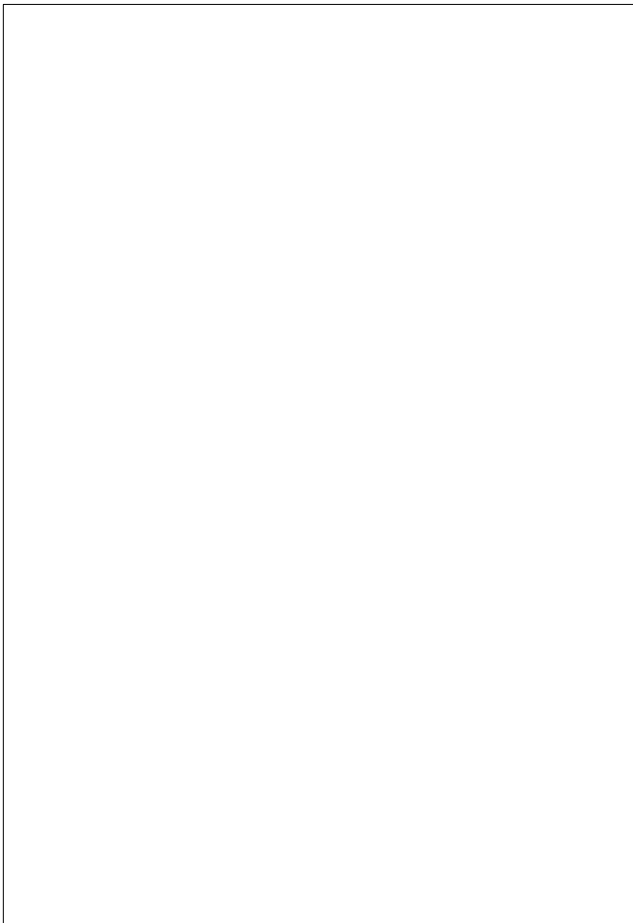
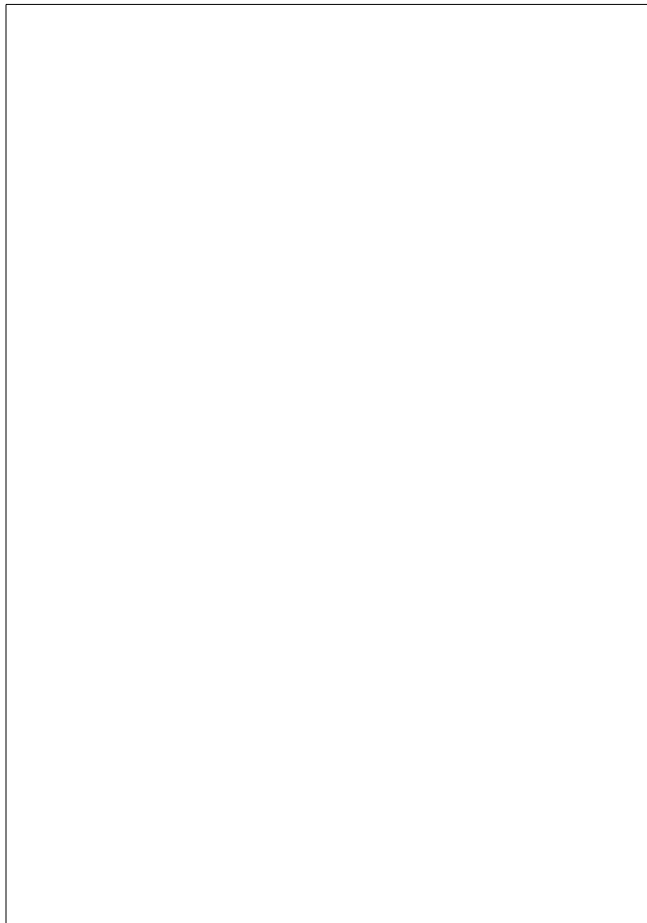
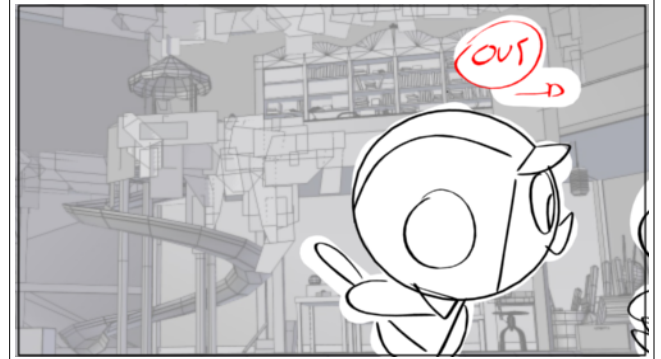



Scene	Duration	Panel	Duration
057	11:20	9	00:12



Scene	Duration	Panel	Duration
058	14:23	1	00:07

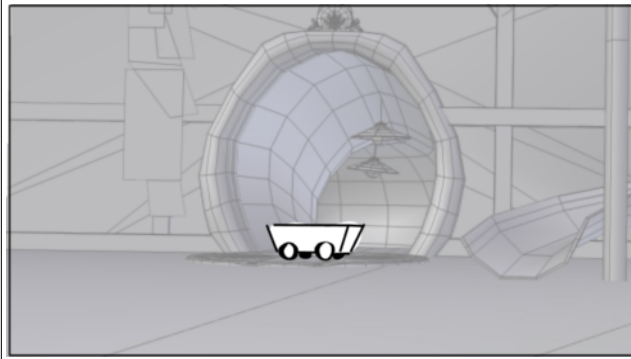

Scene	Duration	Panel	Duration
058	14:23	2	00:18

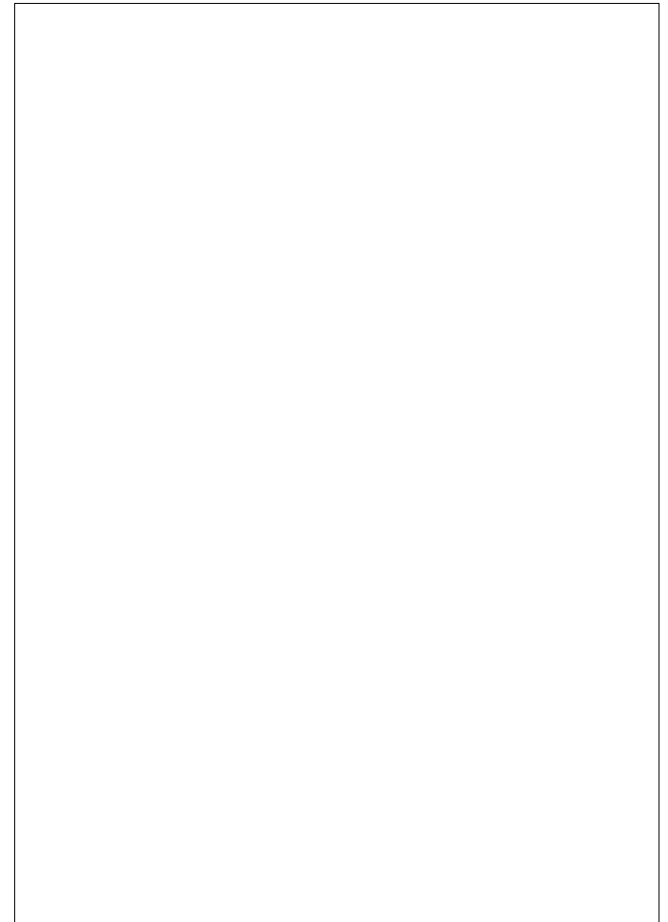
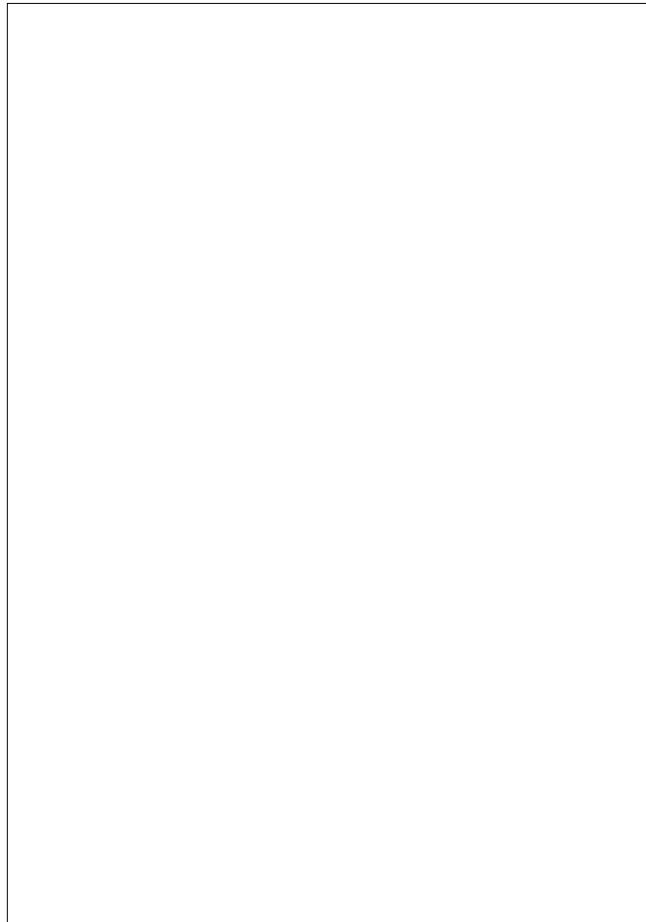
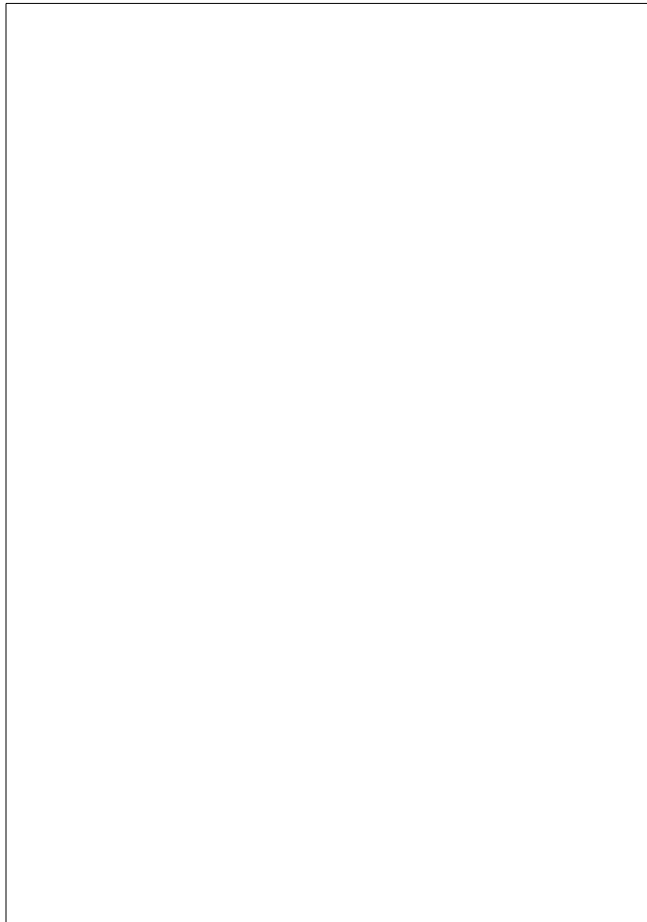
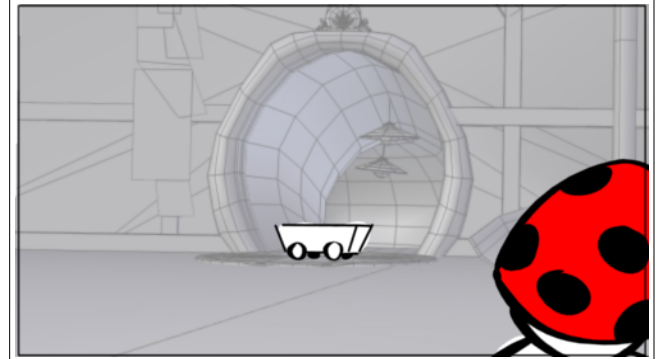



Scene	Duration	Panel	Duration
058	14:23	3	01:00

Scene	Duration	Panel	Duration
058	14:23	4	01:00

Scene	Duration	Panel	Duration
058	14:23	5	01:00

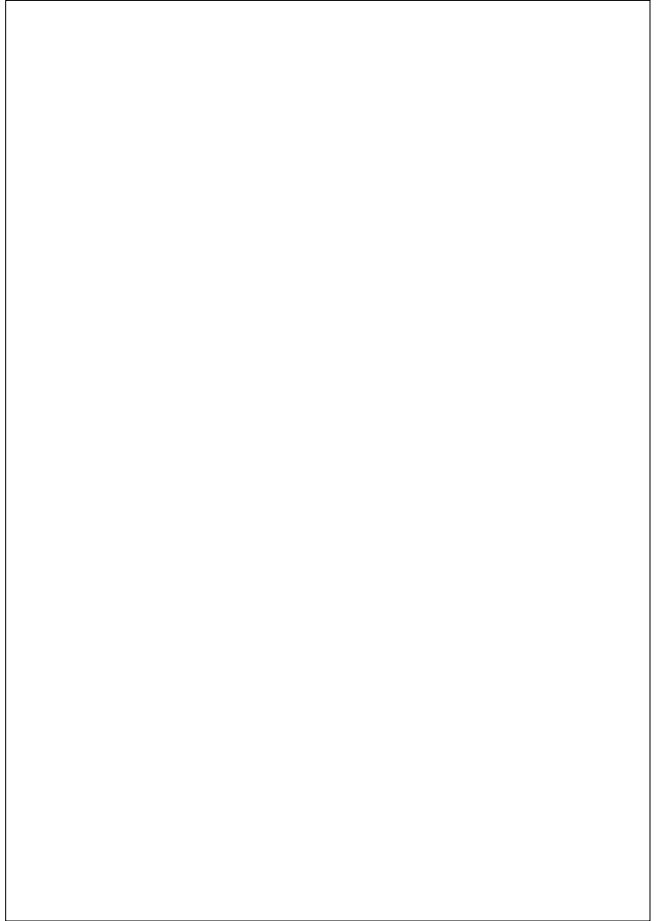
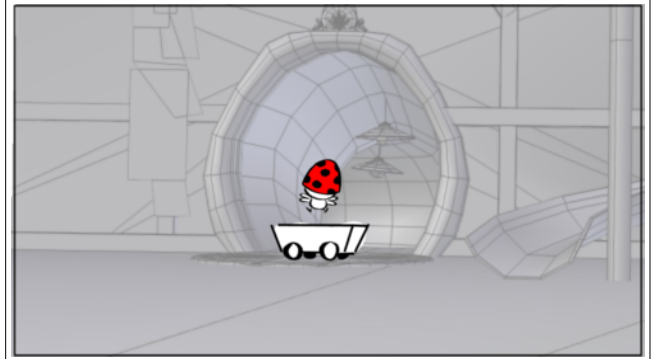
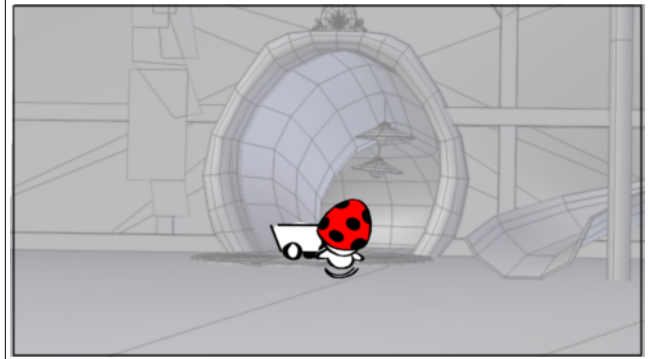
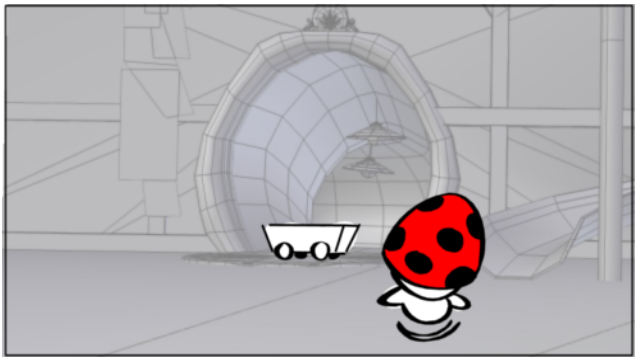

Scene	Duration	Panel	Duration
058	14:23	6	00:12

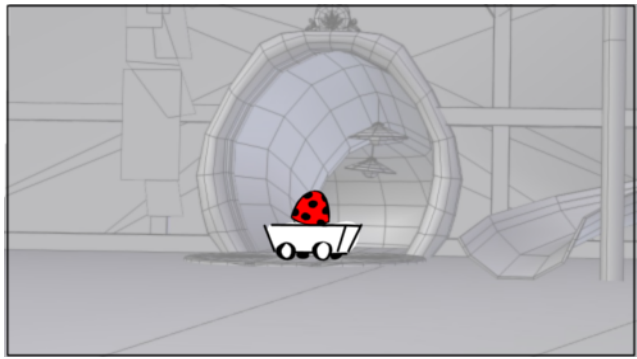

Scene	Duration	Panel	Duration
058	14:23	7	01:00

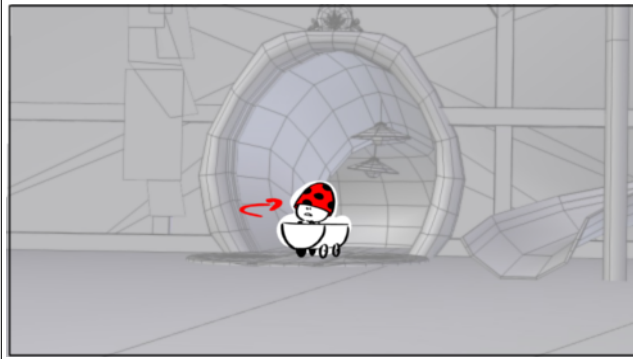

Scene	Duration	Panel	Duration
058	14:23	8	01:00

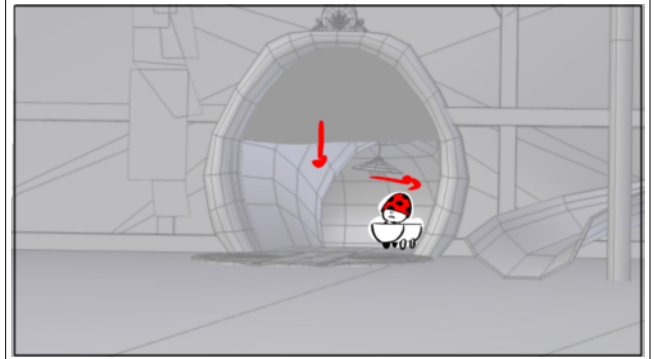

Action Notes

Calimero saute dans le wagonnet



Scene	Duration	Panel	Duration
058	14:23	9	01:00

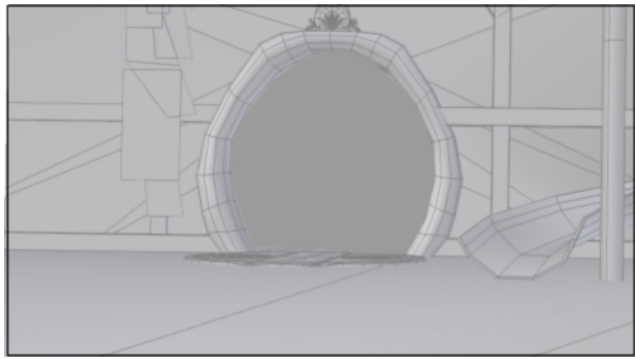

Scene	Duration	Panel	Duration
058	14:23	10	01:01

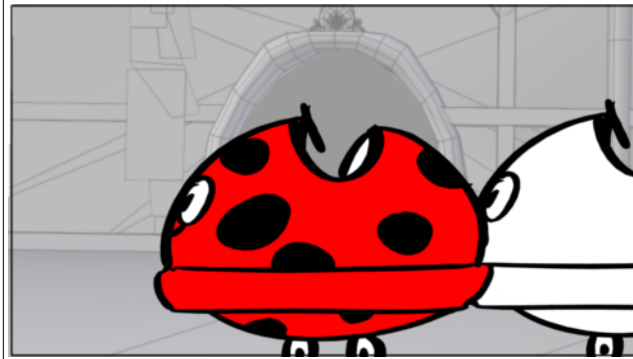

Scene	Duration	Panel	Duration
058	14:23	11	01:05



Action Notes
et disparaît par le passage secret

Scene	Duration	Panel	Duration
058	14:23	12	02:05

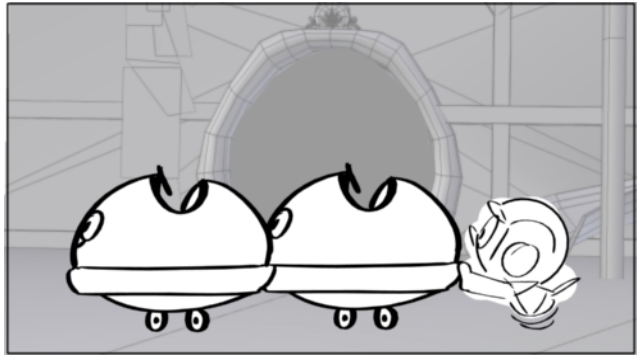

Scene	Duration	Panel	Duration
058	14:23	13	01:00

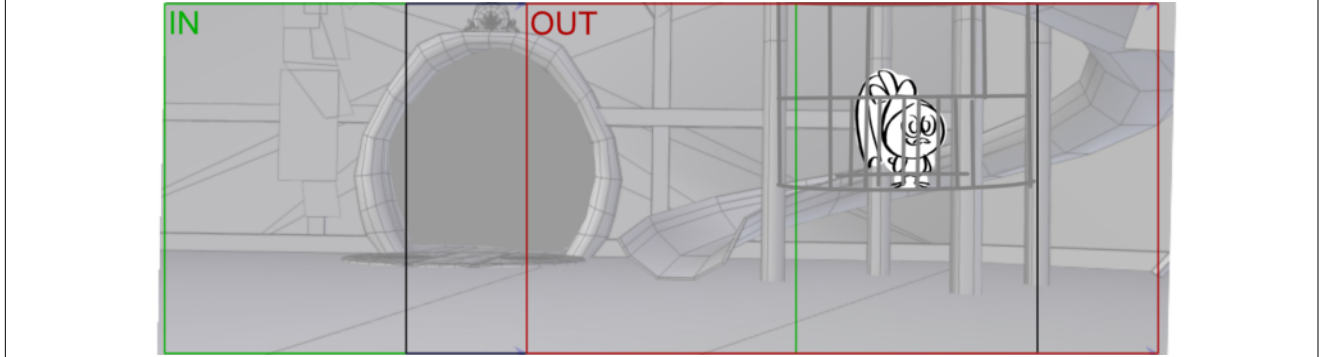



Scene	Duration	Panel	Duration
058	14:23	14	00:13

Scene	Duration	Panel	Duration
058	14:23	15	00:13

Scene	Duration	Panel	Duration
058	14:23	16	00:12

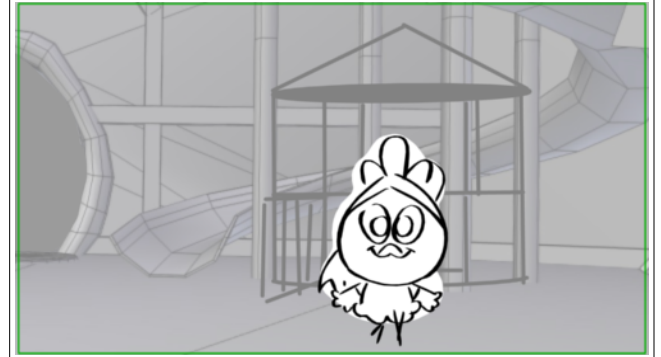
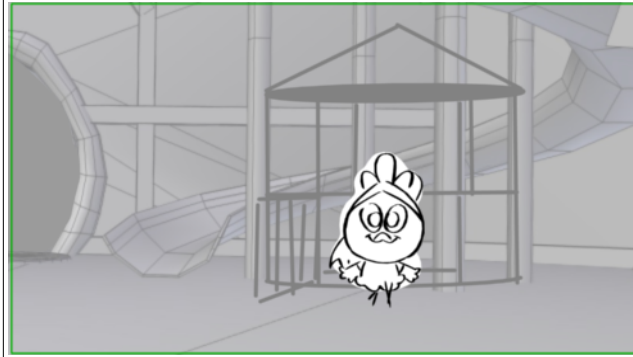
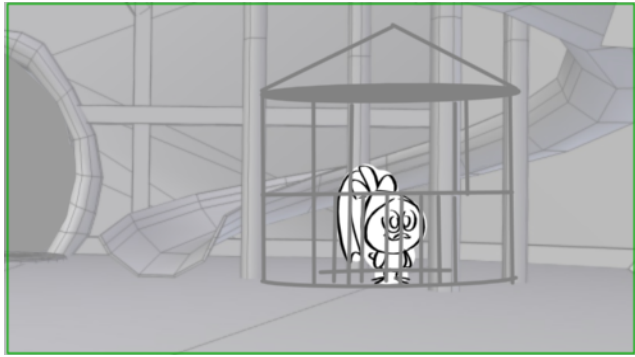

Action Notes

Priscilla arrive par l'ascenseur



Scene	Duration	Panel	Duration
058	14:23	17	00:12

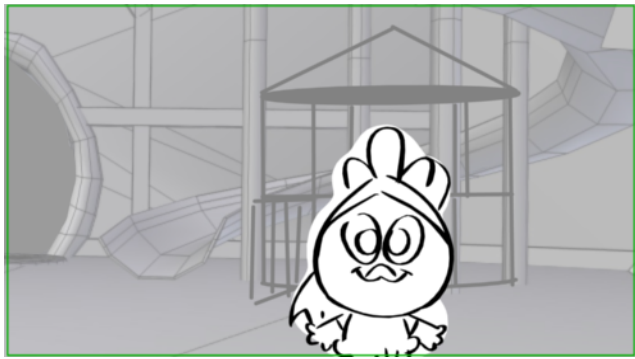

Scene	Duration	Panel	Duration
059	05:05	1	00:15

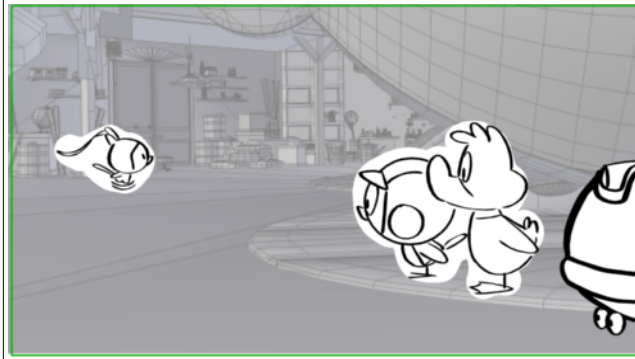

Scene	Duration	Panel	Duration
059	05:05	2	00:15

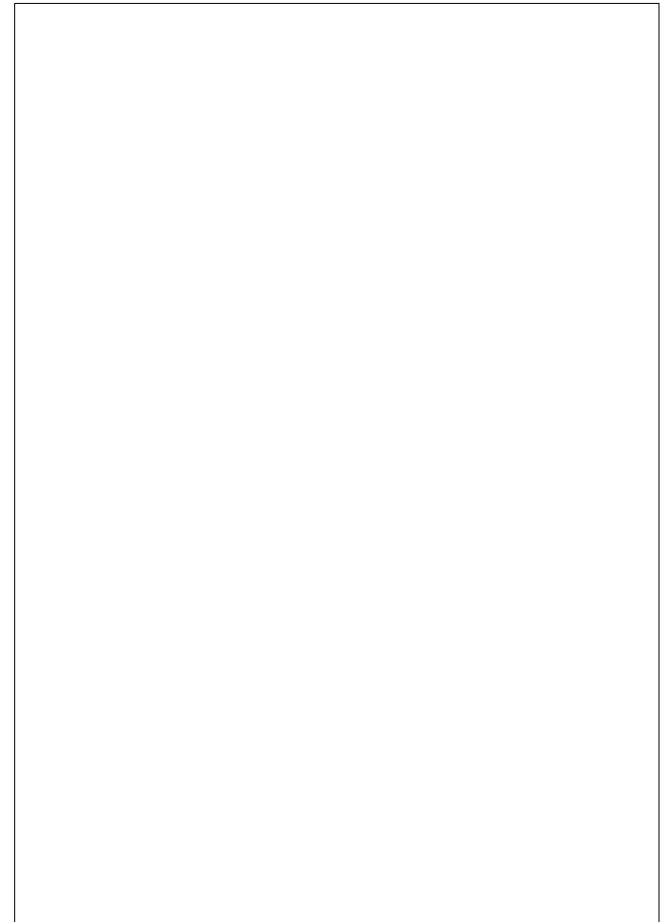
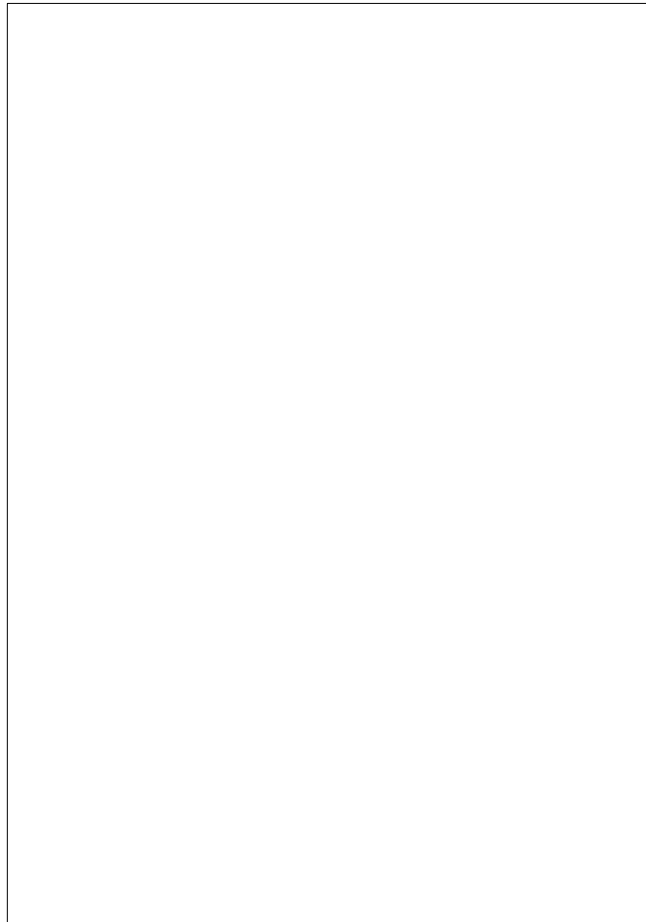
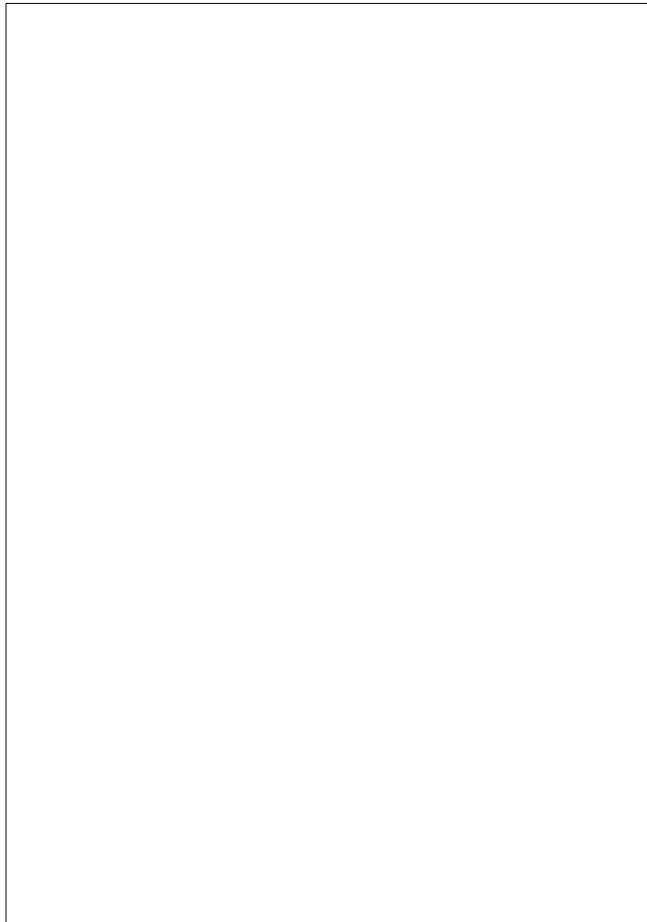
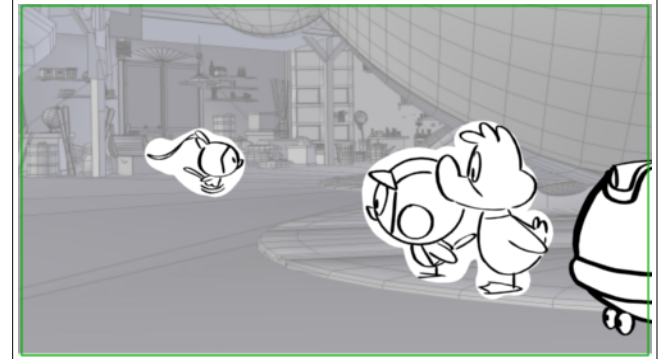



Scene	Duration	Panel	Duration
059	05:05	3	00:21

NO PANEL

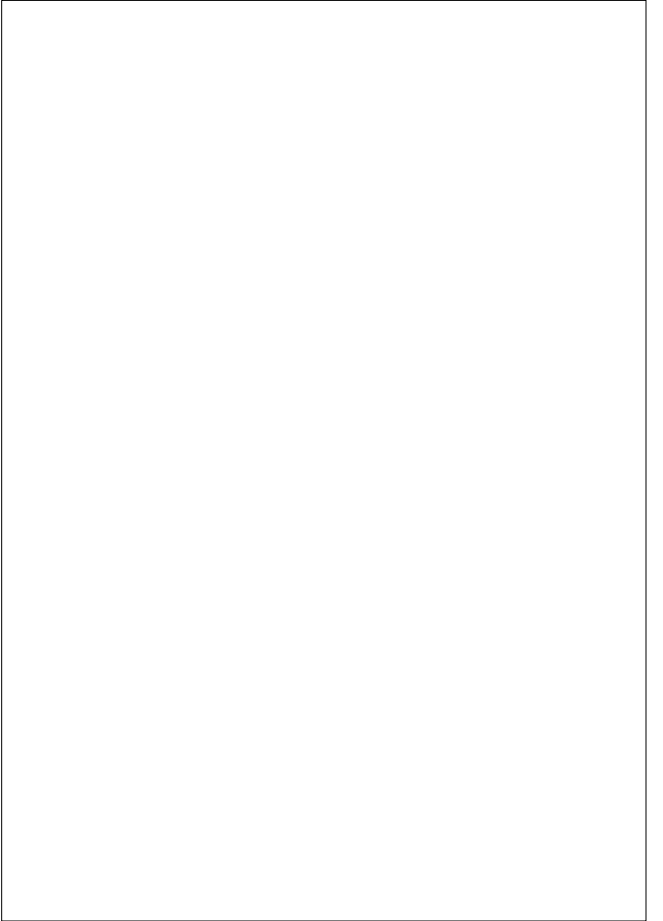
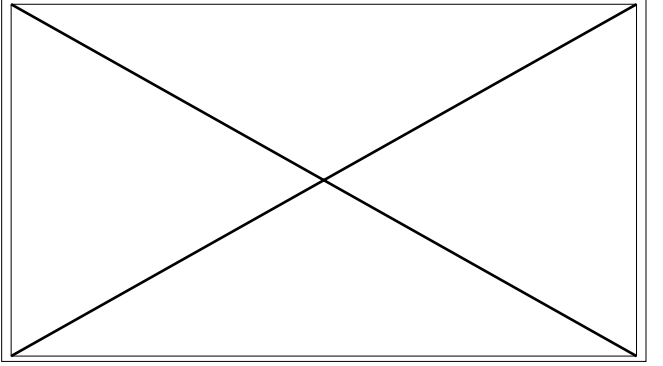
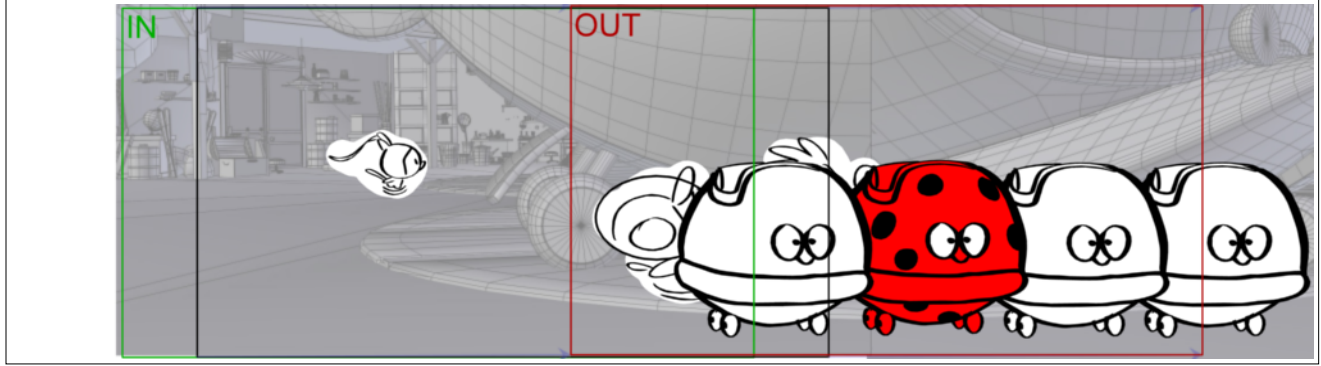



Scene	Duration	Panel	Duration
059	05:05	4	00:20

Scene	Duration	Panel	Duration
059	05:05	5	01:13

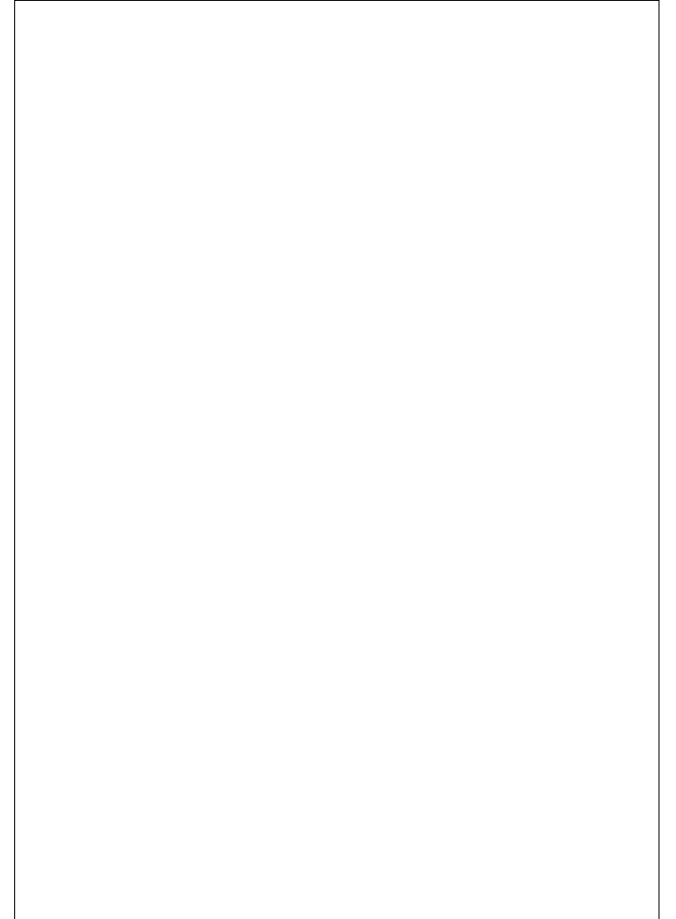
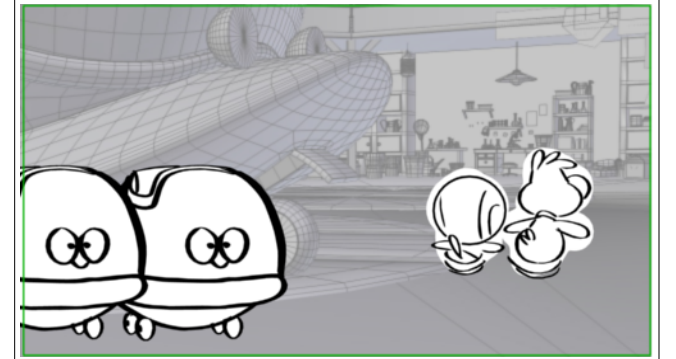
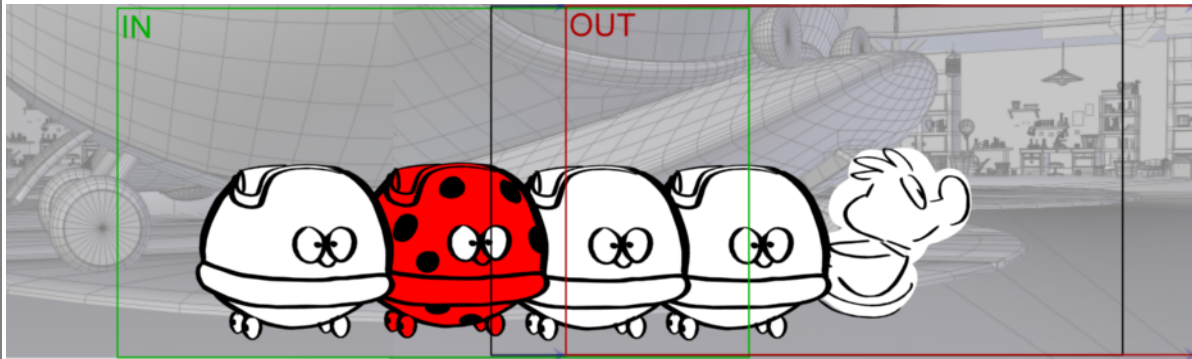



Scene	Duration	Panel	Duration
059	05:05	6	00:21

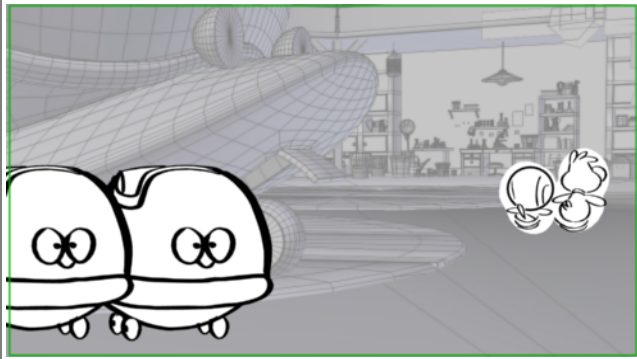

Scene	Duration	Panel	Duration
060	06:08	1	00:09

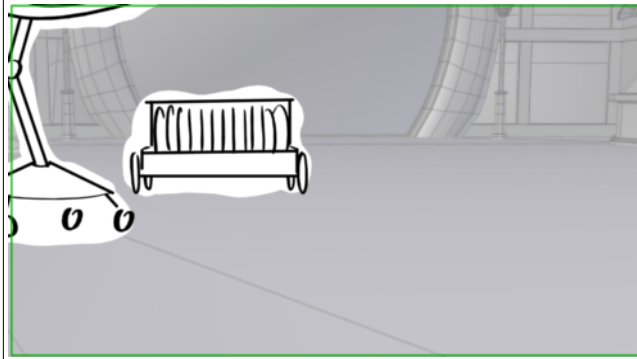

Scene	Duration	Panel	Duration
060	06:08	2	01:00

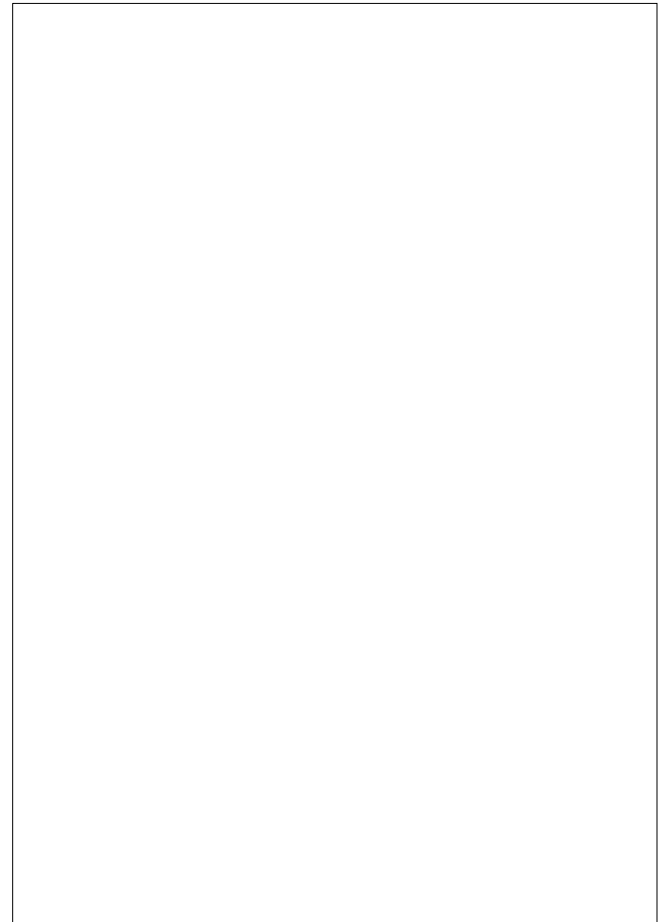
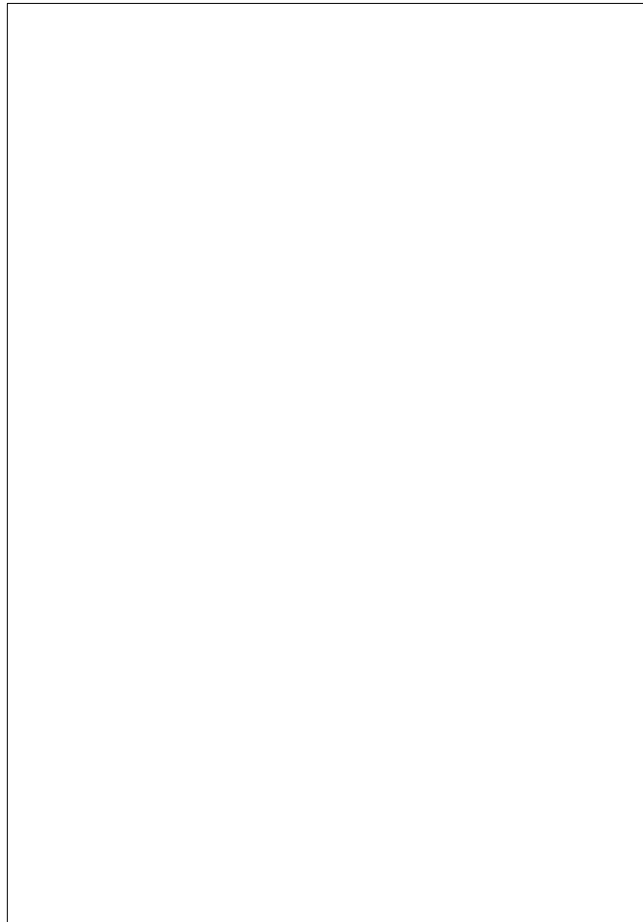
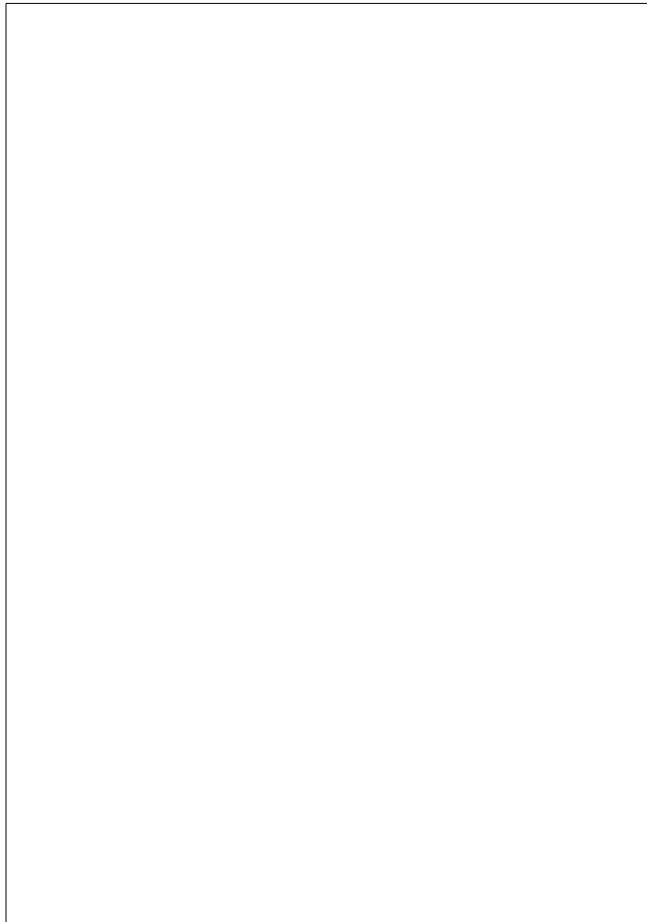
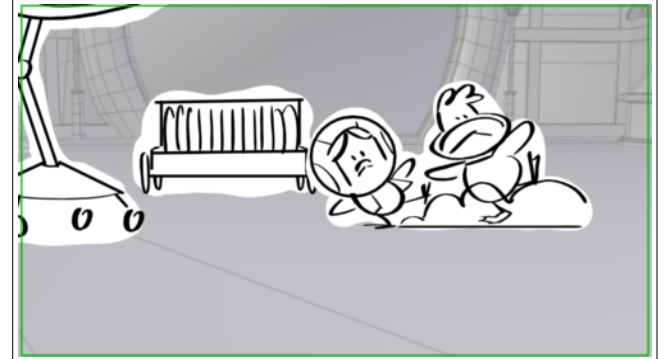

Scene	Duration	Panel	Duration
060	06:08	3	01:00

Scene	Duration	Panel	Duration
060	06:08	4	01:00

Scene	Duration	Panel	Duration
060	06:08	5	01:00

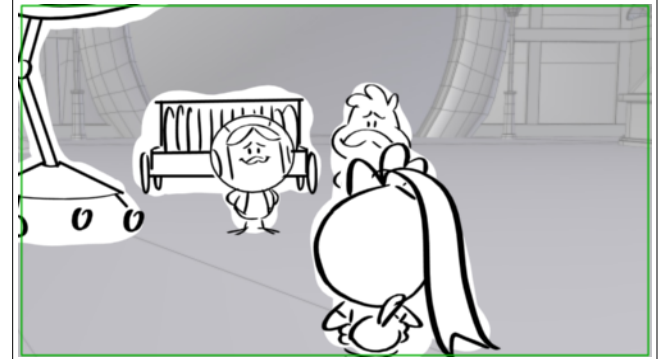
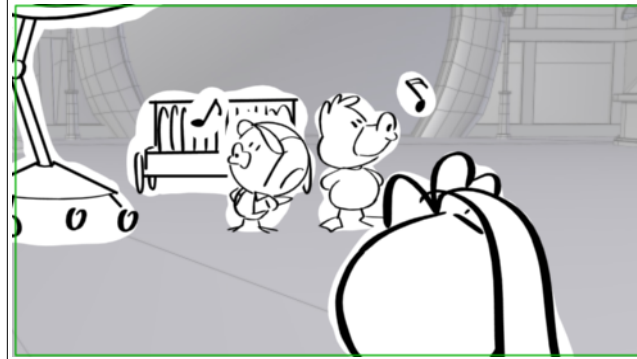
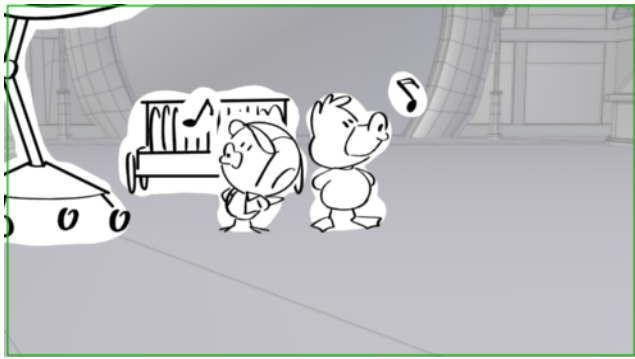

Dialogue
 PICK UP PIERROT/VALERIANO
 Sifflement

Dialogue
 34. PRISCILLA (guillerette)
 Me voilà les copains !

Dialogue
 34. PRISCILLA (guillerette)
 Me voilà les copains !

Scene	Duration	Panel	Duration
060	06:08	6	00:23

Scene	Duration	Panel	Duration
060	06:08	7	01:01

Scene	Duration	Panel	Duration
061	04:23	1	00:09

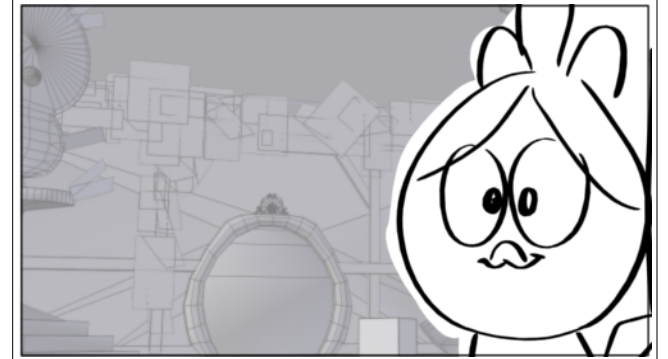
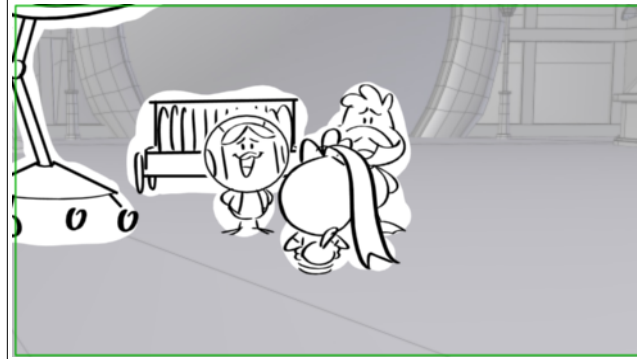
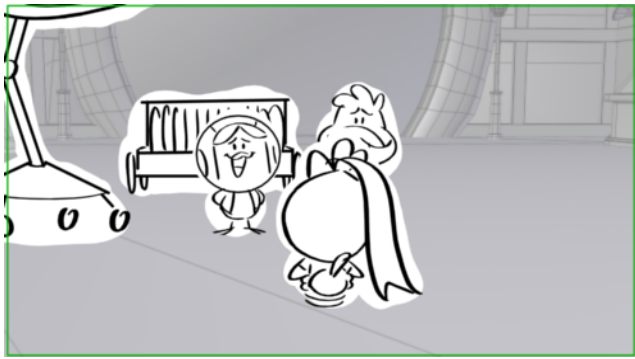

Dialogue
 PICK UP VALERIANO / PIERROT
 Tiens! Salut Priscilla!

Dialogue
 PICK UP VALERIANO / PIERROT
 Tiens! Salut Priscilla!

Dialogue
 36. PRISCILLA (genre « c'est quoi cette
 histoire ? »)
 Hum ?

Scene	Duration	Panel	Duration
061	04:23	2	00:09

**Dialogue**

36. PRISCILLA (genre « c'est quoi cette histoire ? »)

Hum ?

Scene	Duration	Panel	Duration
061	04:23	3	00:05

**Dialogue**

36. PRISCILLA (genre « c'est quoi cette histoire ? »)

Hum ?

Scene	Duration	Panel	Duration
061	04:23	4	00:12

**Dialogue**

36. PRISCILLA (genre « c'est quoi cette histoire ? »)

Hum ?

Scene	Duration	Panel	Duration
061	04:23	5	01:00

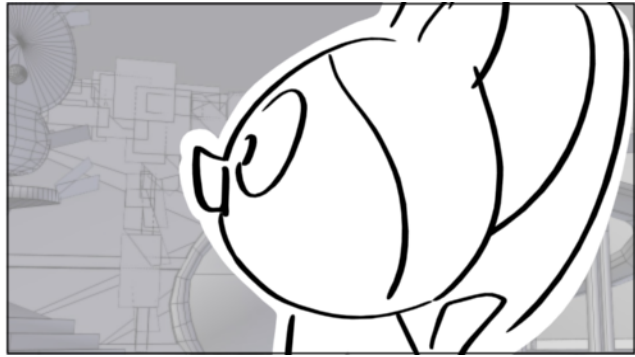

Scene	Duration	Panel	Duration
061	04:23	6	01:00



Scene	Duration	Panel	Duration
061	04:23	7	01:13



Dialogue

36. PRISCILLA (genre « c'est quoi cette histoire ? »)

Il est où Caliméro ?

Scene	Duration	Panel	Duration
062	10:13	1	00:12



Scene	Duration	Panel	Duration
062	10:13	2	00:11



Dialogue
SFX GLUPS

Scene	Duration	Panel	Duration
062	10:13	3	01:00



Dialogue
37. VALERIANO (gêné)
Caliméro ?

Scene	Duration	Panel	Duration
062	10:13	4	00:11

**Dialogue**

37. VALERIANO (gêné)
Heu,

Scene	Duration	Panel	Duration
062	10:13	5	00:08

**Dialogue**

35. PIERROT (bafouillant, gaffeur,
reculant)
on n?a rien droit de te dire Priscilla!

Scene	Duration	Panel	Duration
062	10:13	6	00:22

**Dialogue**

35. PIERROT (bafouillant, gaffeur,
reculant)
on n?a rien droit de te dire Priscilla!

Scene	Duration	Panel	Duration
062	10:13	7	00:11



Dialogue
 PICK UP VALERIANO
 N'importe quoi!

Scene	Duration	Panel	Duration
062	10:13	8	01:00

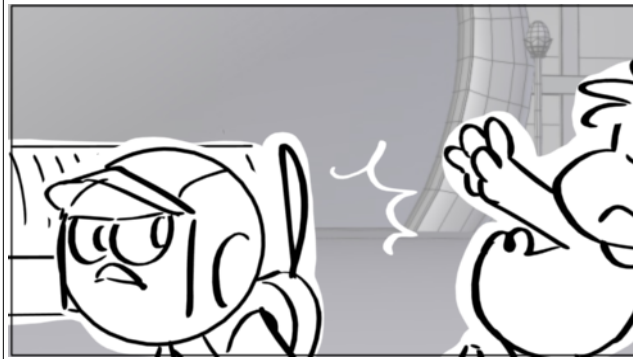

Dialogue
 PICK UP VALERIANO
 N'importe quoi!

Scene	Duration	Panel	Duration
062	10:13	9	01:00



Dialogue
 37. VALERIANO (gêné)
 il revient?

Scene	Duration	Panel	Duration
062	10:13	10	00:06



Dialogue
 37. VALERIANO (gêné)
 il est allé au,

Scene	Duration	Panel	Duration
062	10:13	11	00:16



Dialogue
 37. VALERIANO (gêné)
 il est allé au,

Scene	Duration	Panel	Duration
062	10:13	12	01:00



Dialogue
 37. VALERIANO (gêné)
 au

Scene	Duration	Panel	Duration
062	10:13	13	00:09



Scene	Duration	Panel	Duration
062	10:13	14	01:00

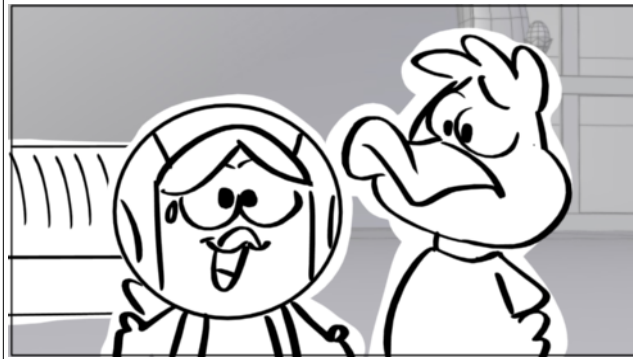

Dialogue
 37. VALERIANO (gêné)
 au salon de thé?

Scene	Duration	Panel	Duration
062	10:13	15	00:05



Dialogue
 PICK UP PIERROT
 C'est ça!

Scene	Duration	Panel	Duration
062	10:13	16	00:05

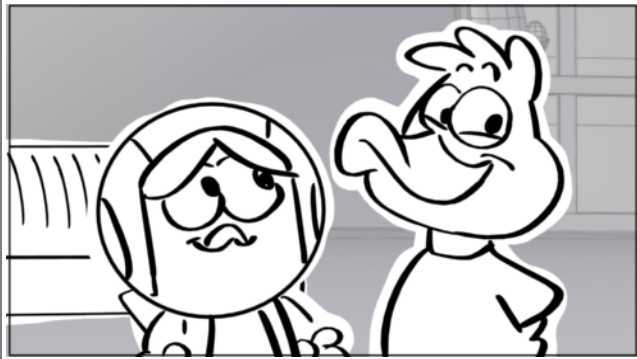

Dialogue
 PICK UP PIERROT
 C'est ça!

Scene	Duration	Panel	Duration
062	10:13	17	00:06



Dialogue
 PICK UP PIERROT
 C'est ça!

Scene	Duration	Panel	Duration
062	10:13	18	00:05



Dialogue
 PICK UP PIERROT
 C'est ça!

Scene	Duration	Panel	Duration
062	10:13	19	00:06

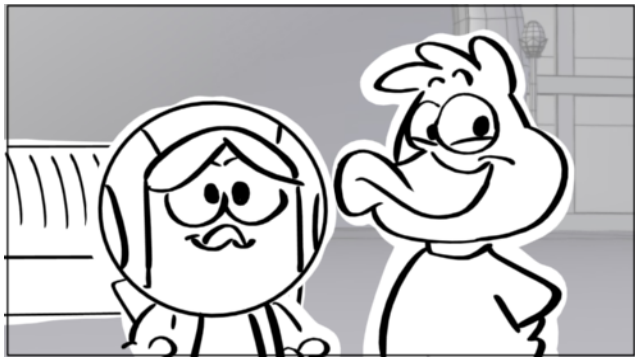
**Dialogue**

PICK UP PIERROT
C'est ça!

Scene	Duration	Panel	Duration
062	10:13	20	00:05

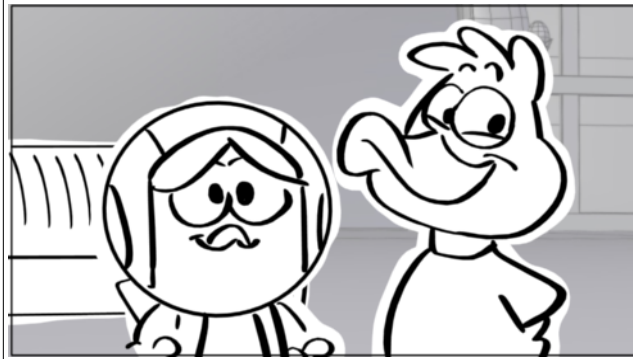

Scene	Duration	Panel	Duration
063	03:03	1	00:08

**Dialogue**

38. PIERROT (hésitant puis s'emballant
dans son mensonge)
? pour, pour,

Scene	Duration	Panel	Duration
063	03:03	2	00:03



Dialogue

38. PIERROT (hésitant puis s'emballant dans son mensonge)
? pour, pour,

Scene	Duration	Panel	Duration
063	03:03	3	00:17

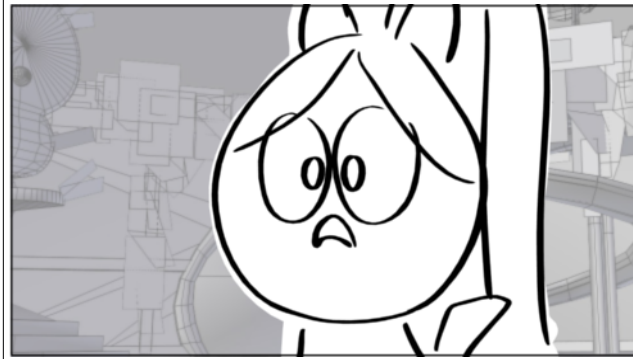

Dialogue

38. PIERROT (hésitant puis s'emballant dans son mensonge)
? pour, pour,

Scene	Duration	Panel	Duration
063	03:03	4	01:00



Dialogue

38. PIERROT (hésitant puis s'emballant dans son mensonge)
pour manger

Scene	Duration	Panel	Duration
063	03:03	5	01:00

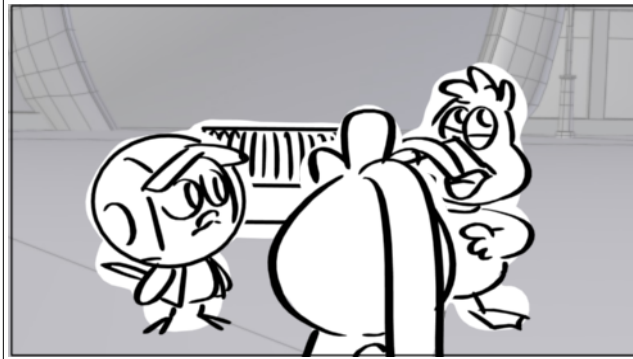

Scene	Duration	Panel	Duration
064	03:12	1	00:16

**Dialogue**

38. PIERROT (hésitant puis s'emballant dans son mensonge)
des?des... des

Scene	Duration	Panel	Duration
064	03:12	2	00:12

**Dialogue**

38. PIERROT (hésitant puis s'emballant dans son mensonge)
des tartines de fleurs !

Scene	Duration	Panel	Duration
064	03:12	3	00:13

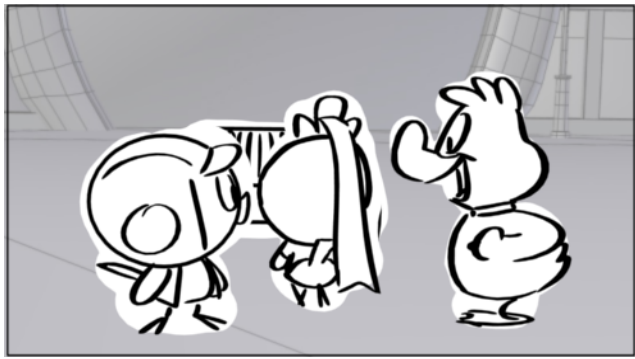
**Dialogue**

38. PIERROT (hésitant puis s'emballant dans son mensonge)
des tartines de fleurs !

Scene	Duration	Panel	Duration
064	03:12	4	01:07

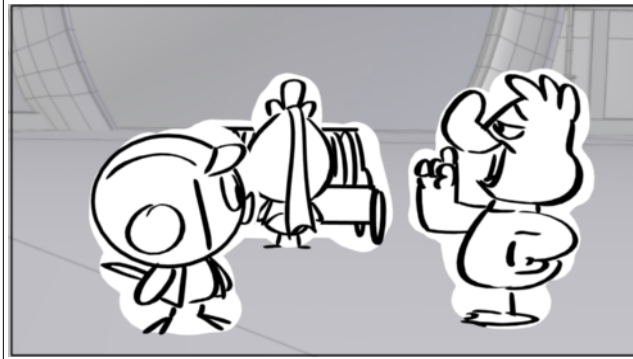
**Dialogue**

38. PIERROT
Avec la cousine de Mme Gigi.

Scene	Duration	Panel	Duration
064	03:12	5	00:14

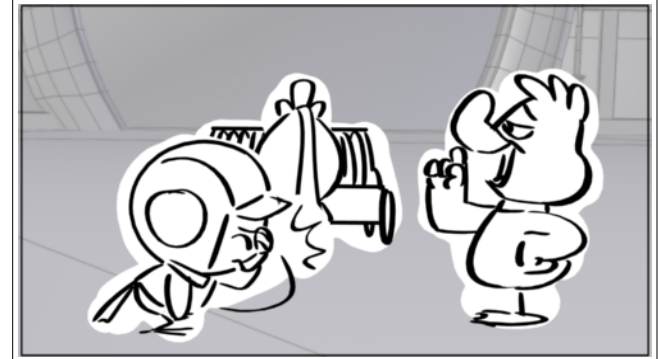
**Dialogue**

38. PIERROT
Avec la cousine de Mme Gigi.

Scene	Duration	Panel	Duration
065	01:18	1	00:12

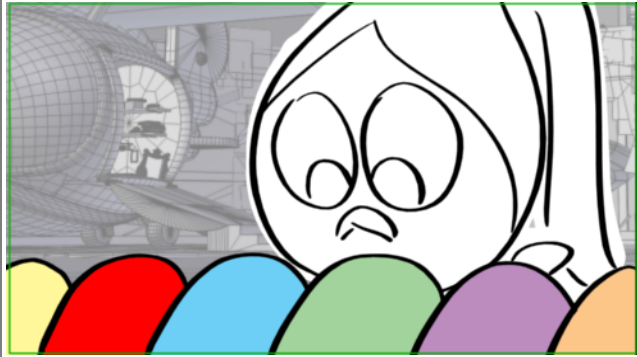

Dialogue
 38. PIERROT
 Celle qui est super forte en pate à modeler?

Scene	Duration	Panel	Duration
065	01:18	2	00:22

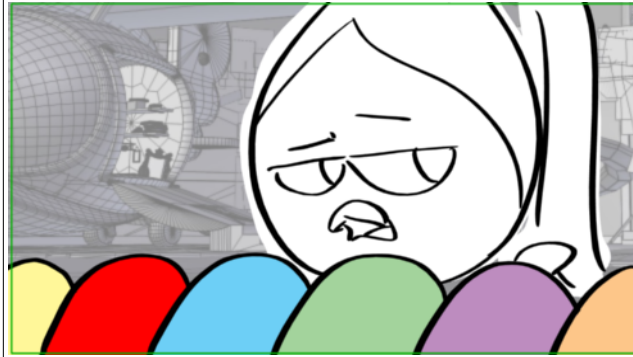

Dialogue
 39. PRISCILLA (suspicieuse)
 Mais bien sûr !

Scene	Duration	Panel	Duration
065	01:18	3	00:09



Dialogue
 39. PRISCILLA (suspicieuse)
 Mais bien sûr !

Scene	Duration	Panel	Duration
066	04:15	1	01:00



Scene	Duration	Panel	Duration
066	04:15	2	00:15



Scene	Duration	Panel	Duration
066	04:15	3	01:00



Dialogue

40. PRISCILLA

Bon maintenant les garçons,

Scene	Duration	Panel	Duration
066	04:15	4	01:00

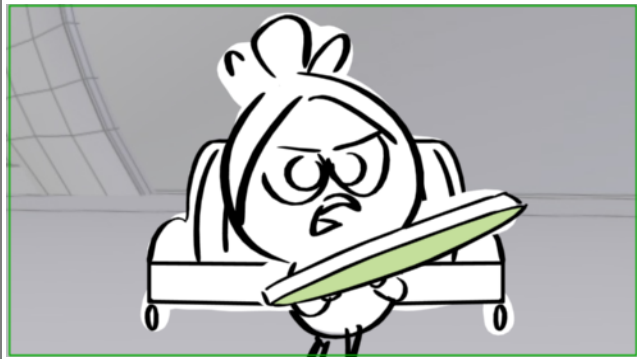

Dialogue
 40. PRISCILLA
 Bon maintenant les garçons,

Scene	Duration	Panel	Duration
066	04:15	5	00:16

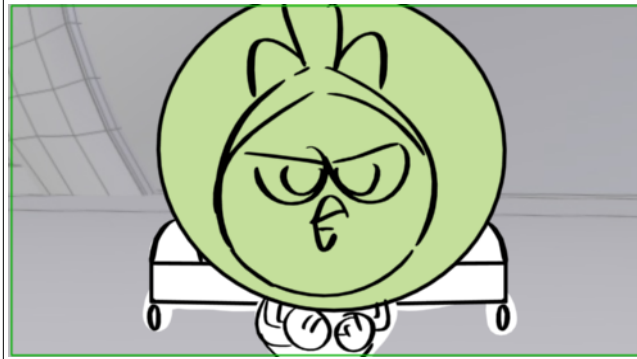

Dialogue
 40. PRISCILLA
 vous m'expliquez !

Scene	Duration	Panel	Duration
066	04:15	6	00:09

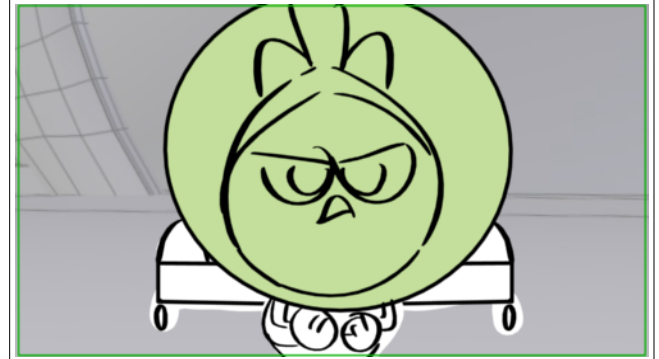

Dialogue
 40. PRISCILLA
 vous m'expliquez !

Scene	Duration	Panel	Duration
067	04:11	1	01:00

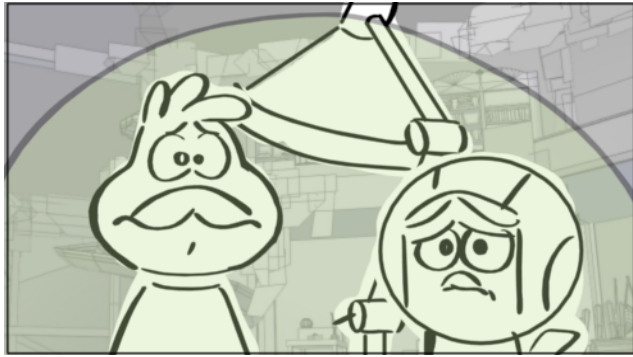

Dialogue
 39. PRISCILLA (suspicieuse)
 cette machine,

Scene	Duration	Panel	Duration
067	04:11	2	01:00

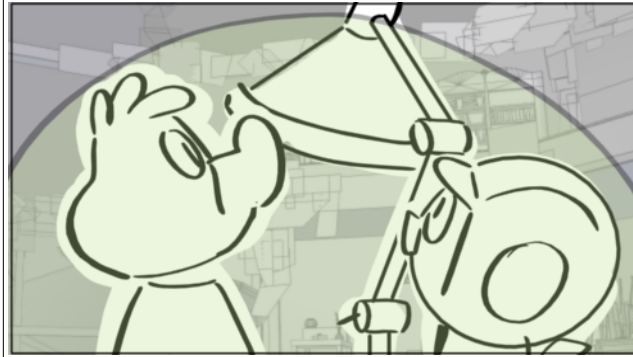

Dialogue
 39. PRISCILLA (suspicieuse)
 cette machine,

Scene	Duration	Panel	Duration
067	04:11	3	01:00



Dialogue
 39. PRISCILLA (suspicieuse)
 c'est quoi ?!

Scene	Duration	Panel	Duration
067	04:11	4	01:11



Dialogue

PICK UP
Rire embarrassé

Scene	Duration	Panel	Duration
068	06:11	1	01:11



Action Notes

2. SORTIE ARRIERE DE CHEZ CALIMERO.
EXT/JOUR

Scene	Duration	Panel	Duration
068	06:11	2	01:13



Scene	Duration	Panel	Duration
068	06:11	3	00:17



Scene	Duration	Panel	Duration
068	06:11	4	00:15



Scene	Duration	Panel	Duration
068	06:11	5	00:17



Action Notes

Caliméro, tête nue, sort discrètement de chez lui par la porte de l'atelier de Gallettoni. Rasant le mur, il tire un chariot sur lequel est posé un carton. Il regarde à droite, à gauche, personne? Il file aussi vite qu'il peut.

Scene	Duration	Panel	Duration
068	06:11	6	00:19



Scene	Duration	Panel	Duration
068	06:11	7	00:19



Scene	Duration	Panel	Duration
069	05:00	1	00:11

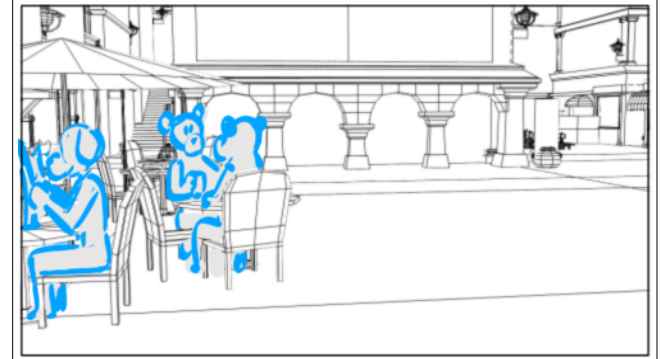

Action Notes

3. PLACE HAUTE, ARCADES SUPERMARCHÉ.
EXT/JOUR

Scene	Duration	Panel	Duration
069	05:00	2	01:02

Scene	Duration	Panel	Duration
069	05:00	3	00:11

Scene	Duration	Panel	Duration
069	05:00	4	00:12

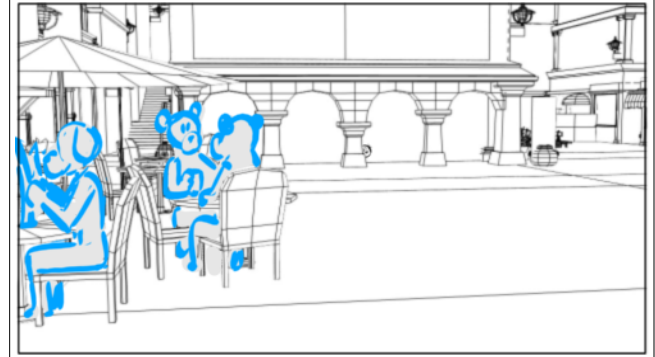
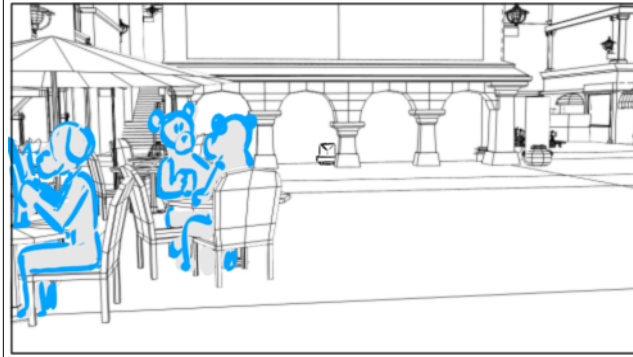
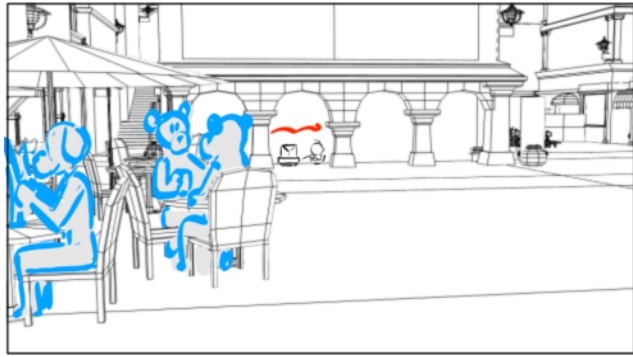

Action Notes

Calimero passe de colonne en colonne en se cachant

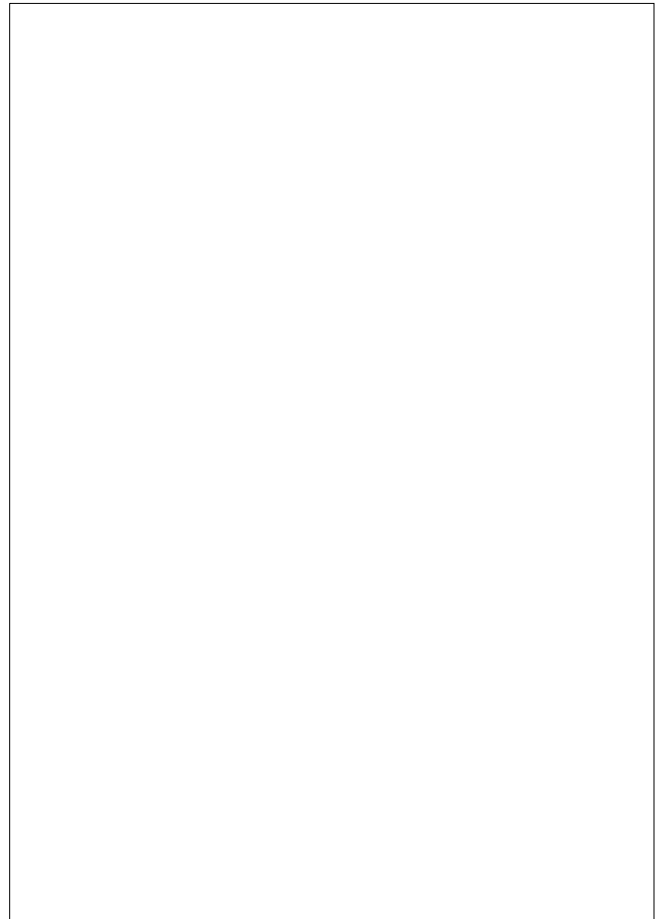
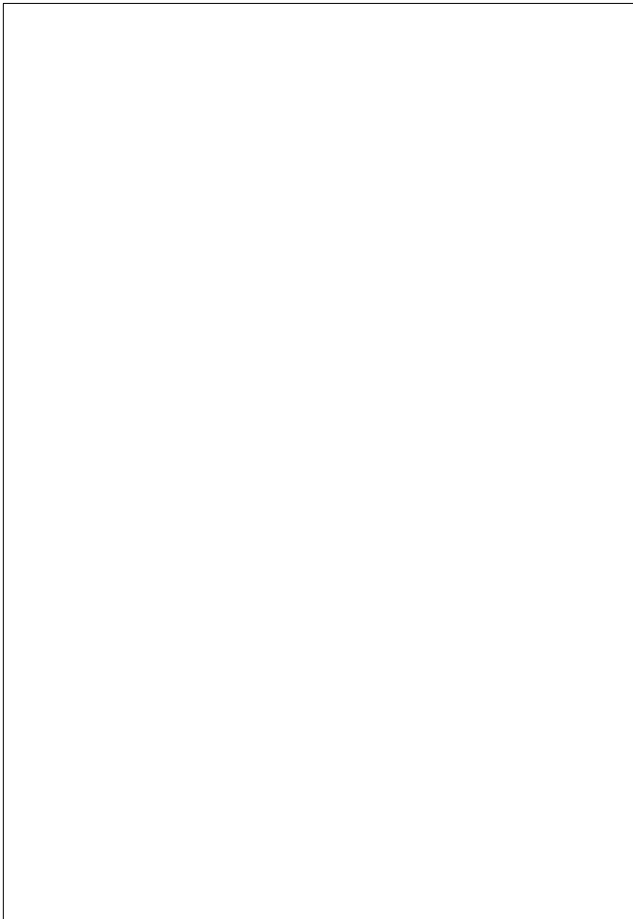



Scene	Duration	Panel	Duration
069	05:00	5	00:13

Scene	Duration	Panel	Duration
069	05:00	6	01:00

Scene	Duration	Panel	Duration
069	05:00	7	00:18

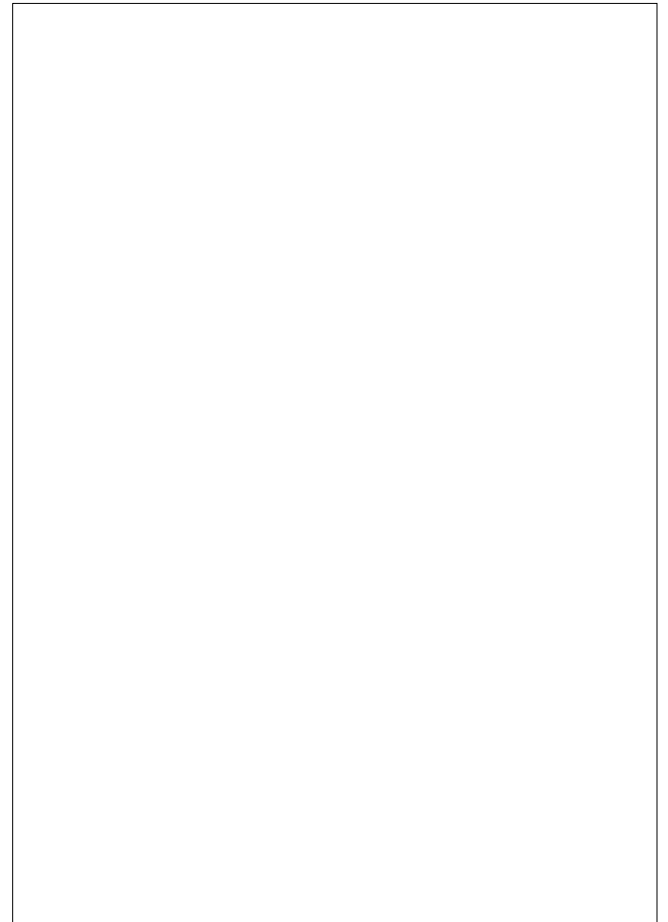
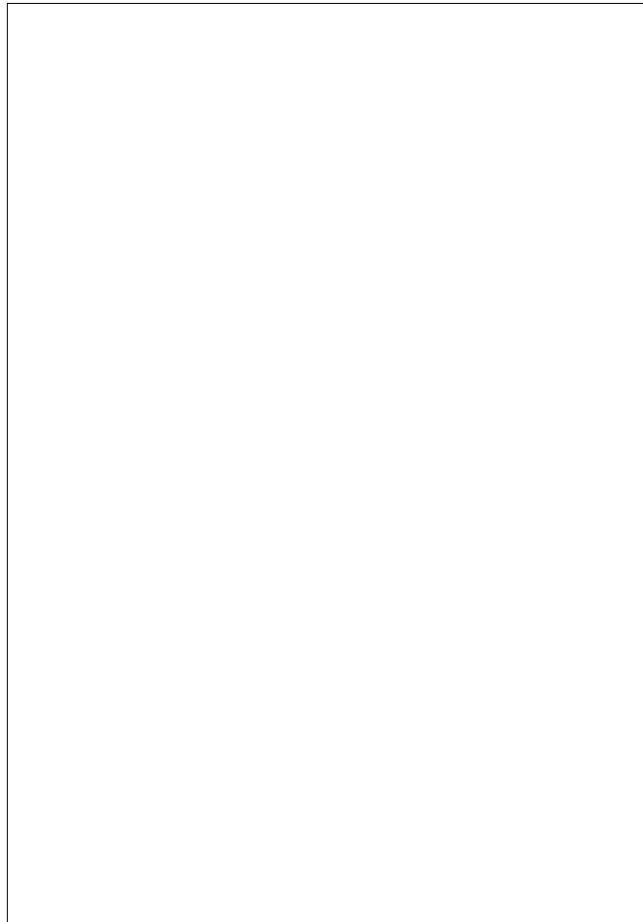
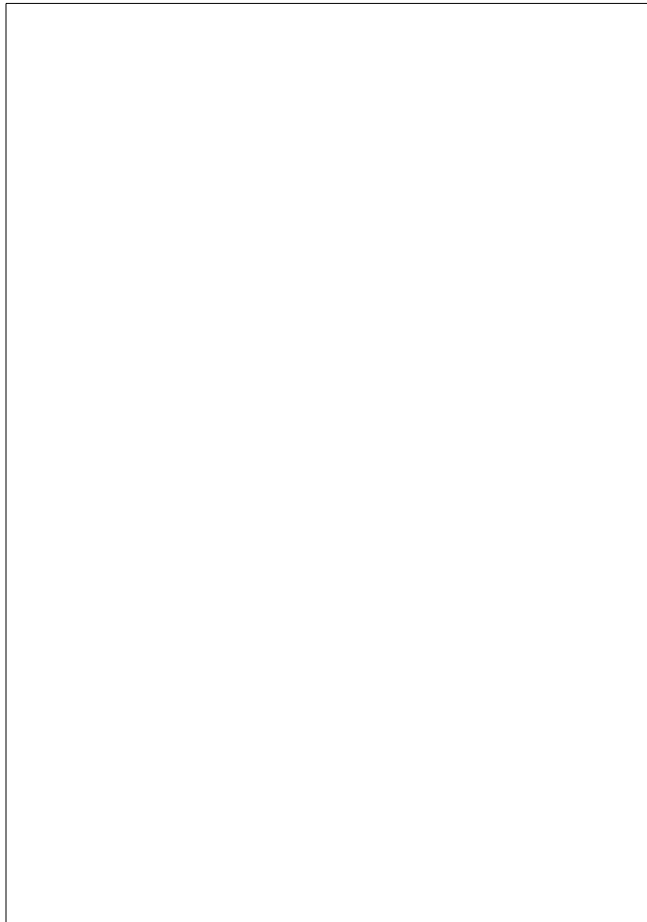
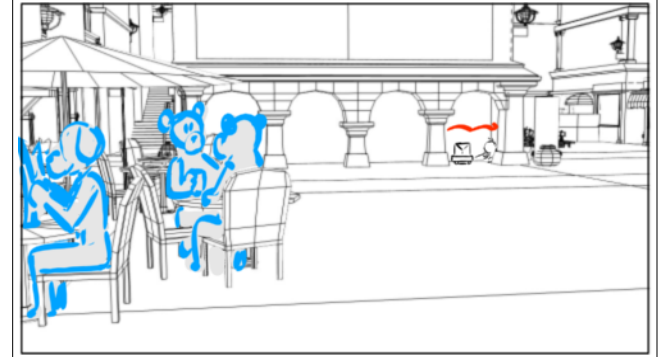
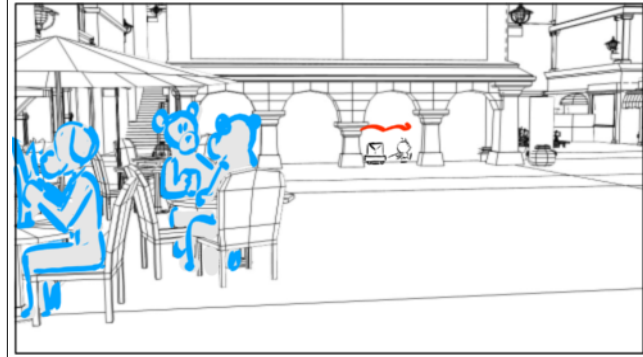
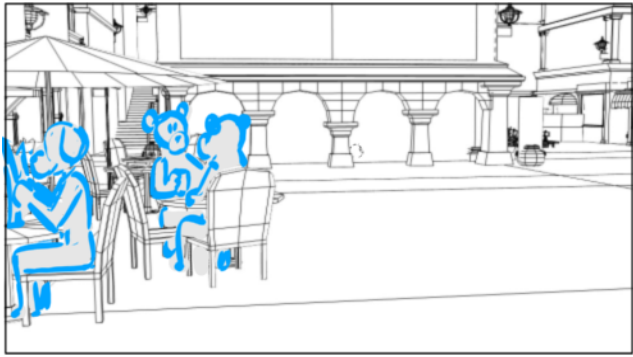

Scene	Duration	Panel	Duration
069	05:00	8	00:08

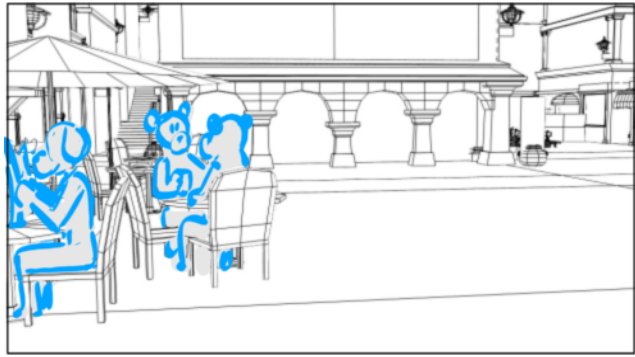

Scene	Duration	Panel	Duration
070	09:04	1	00:17

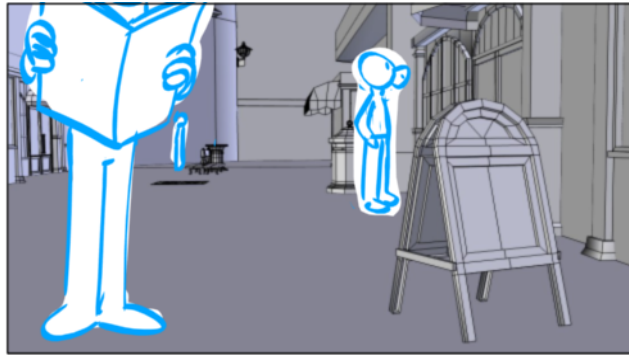

Scene	Duration	Panel	Duration
070	09:04	2	00:10

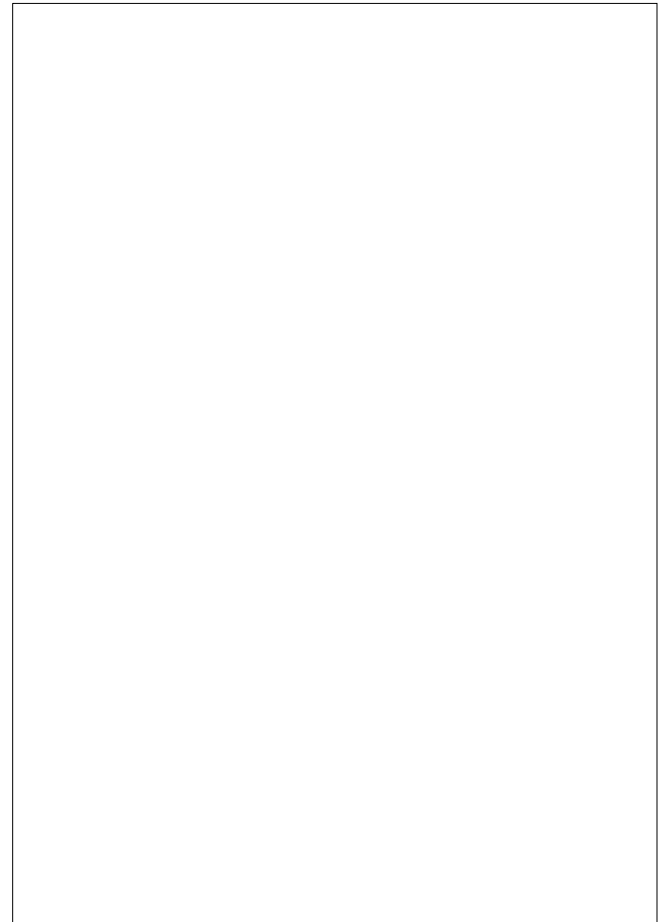
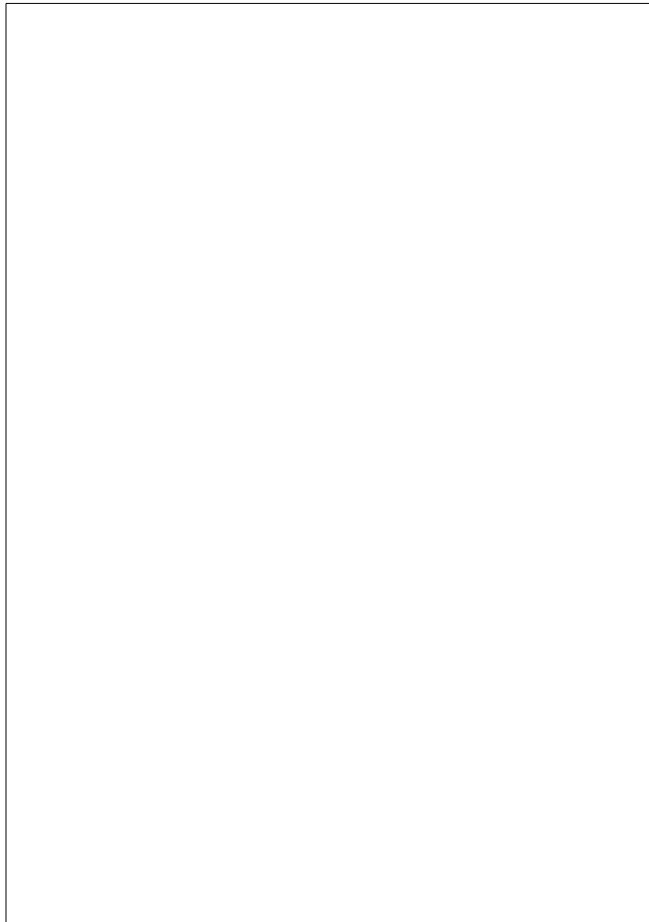
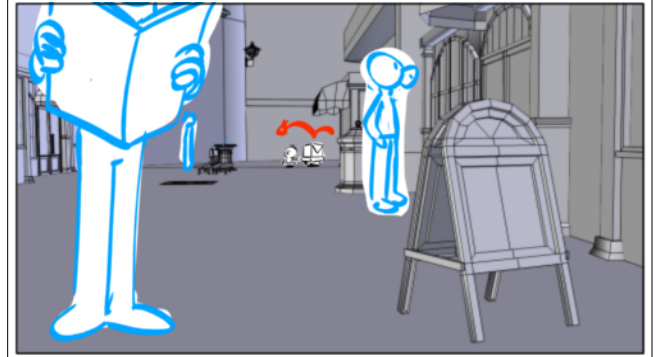



Scene	Duration	Panel	Duration
070	09:04	3	00:10

Scene	Duration	Panel	Duration
070	09:04	4	00:17

Scene	Duration	Panel	Duration
070	09:04	5	00:15

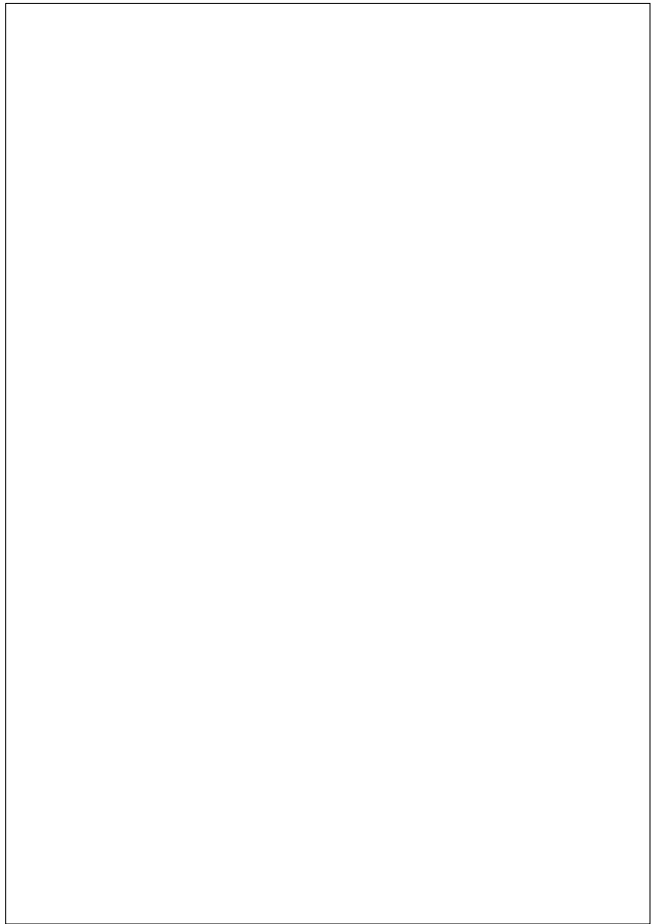
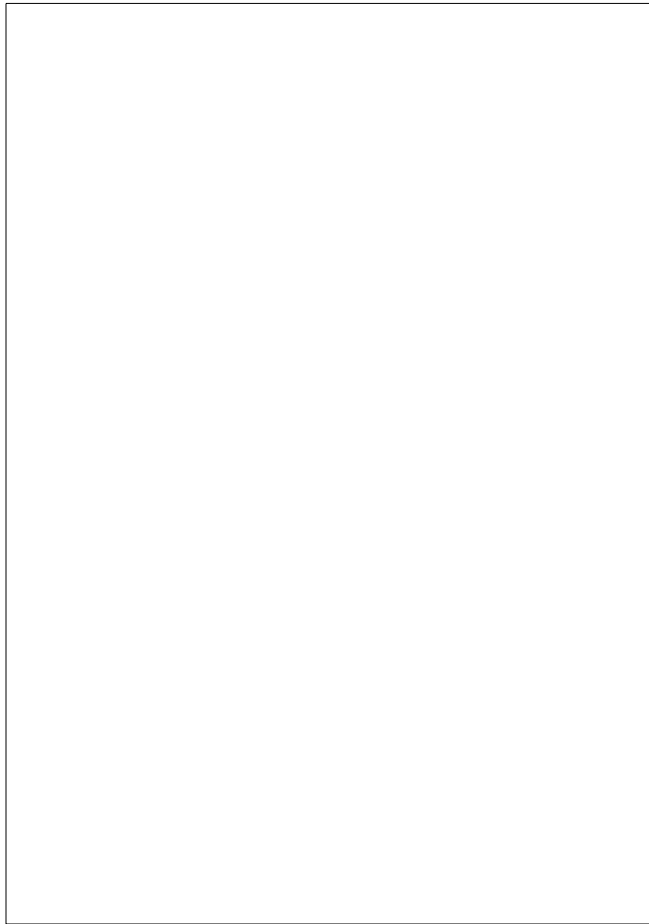
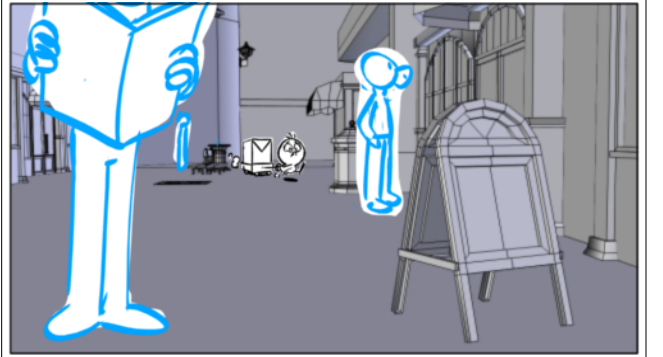
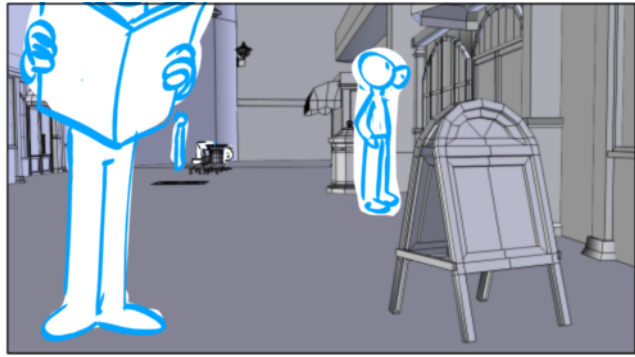
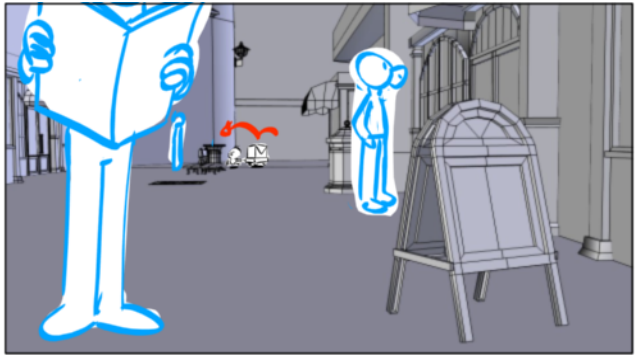



Scene	Duration	Panel	Duration
070	09:04	6	00:15

Scene	Duration	Panel	Duration
070	09:04	7	00:17

Scene	Duration	Panel	Duration
070	09:04	8	00:13

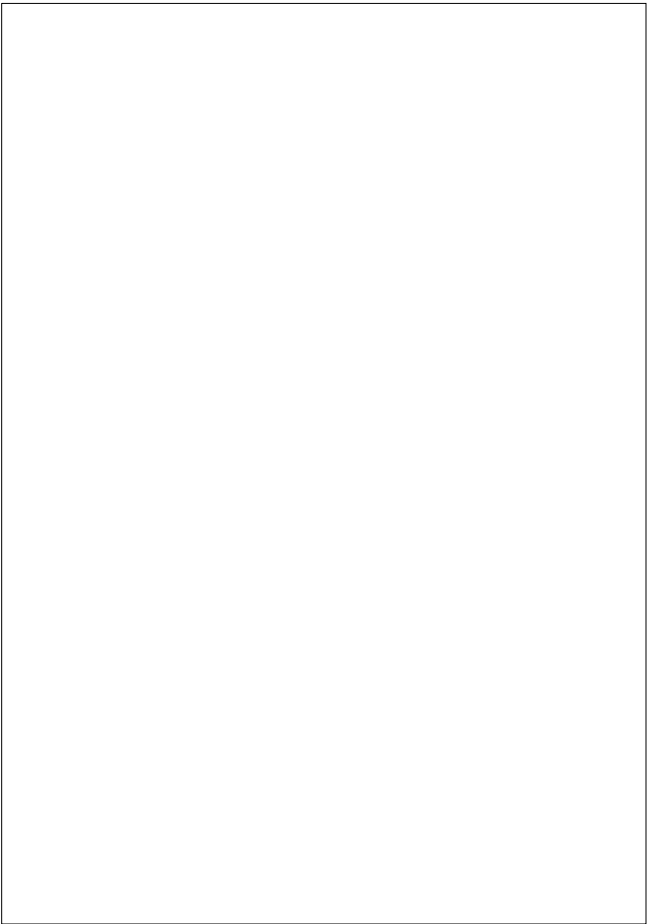
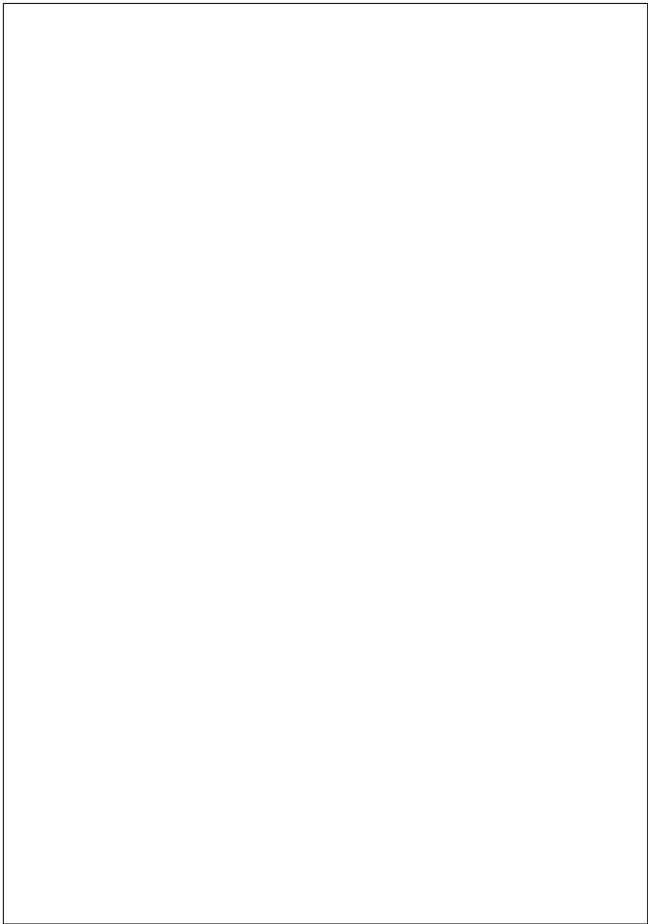
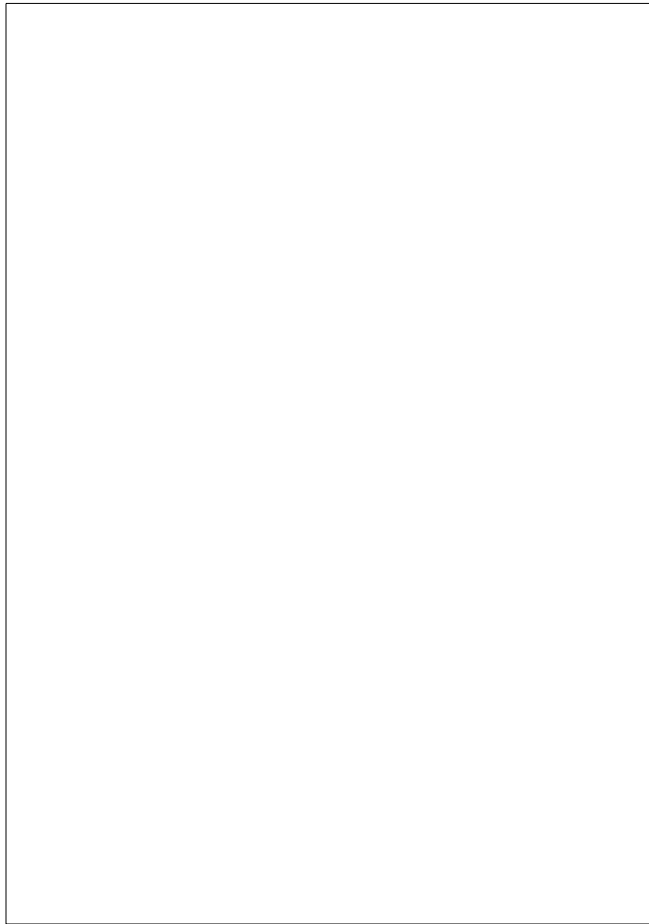
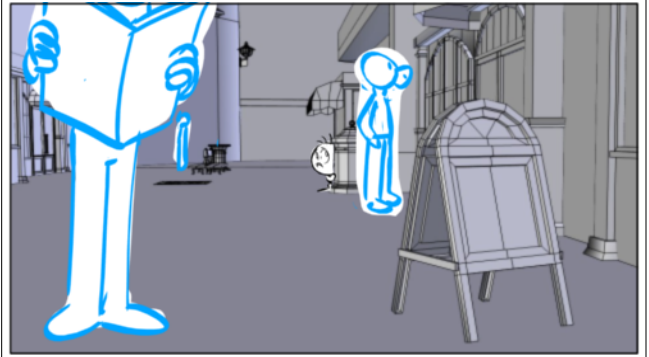
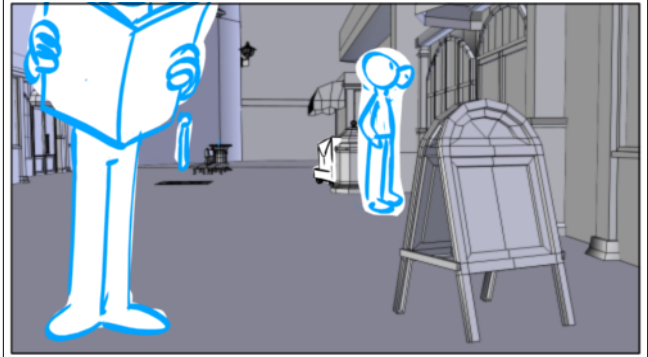
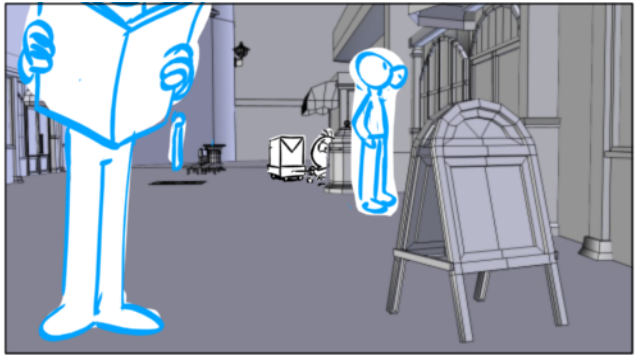



Scene	Duration	Panel	Duration
070	09:04	9	00:14

Scene	Duration	Panel	Duration
070	09:04	10	00:14

Scene	Duration	Panel	Duration
070	09:04	11	00:15

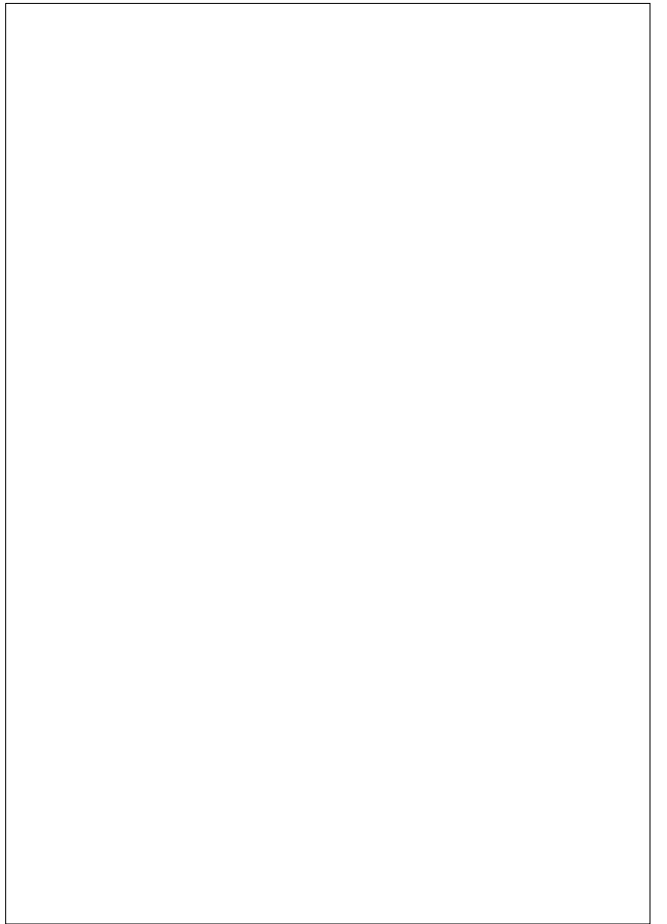
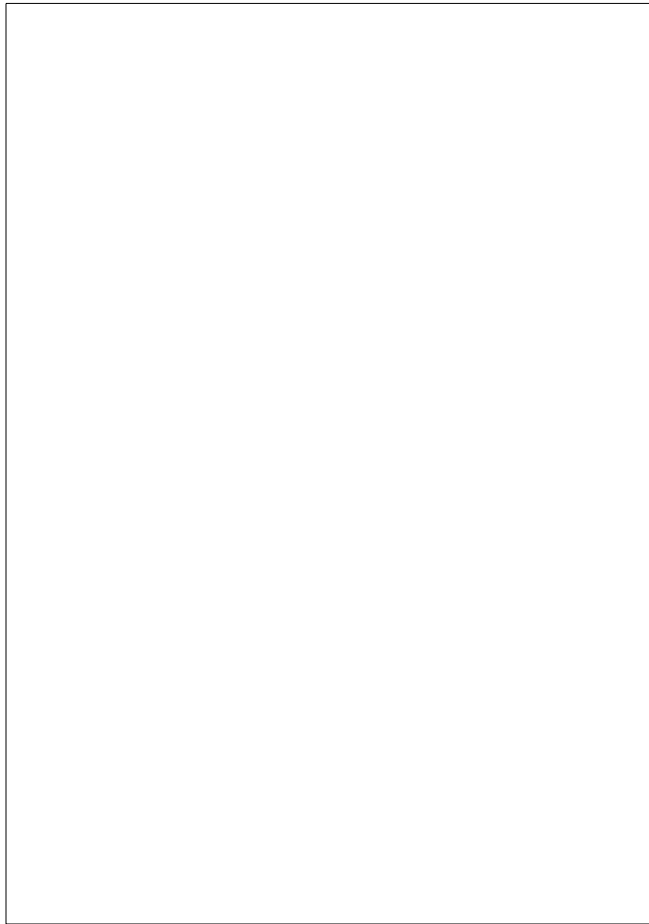
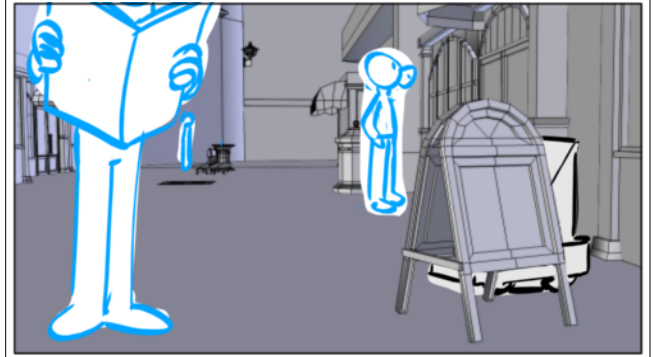
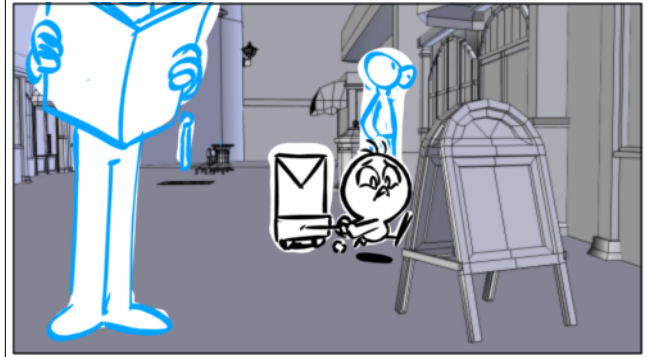
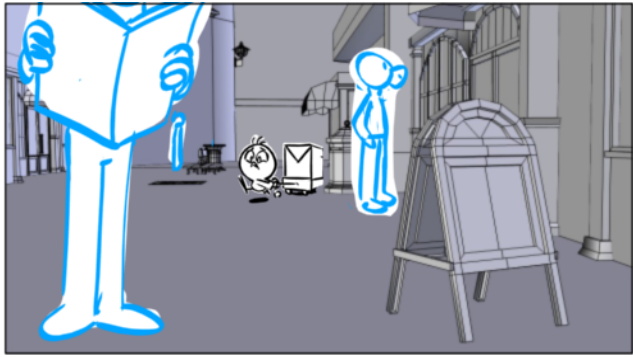



Scene	Duration	Panel	Duration
070	09:04	12	00:18

Scene	Duration	Panel	Duration
070	09:04	13	00:18

Scene	Duration	Panel	Duration
070	09:04	14	00:18

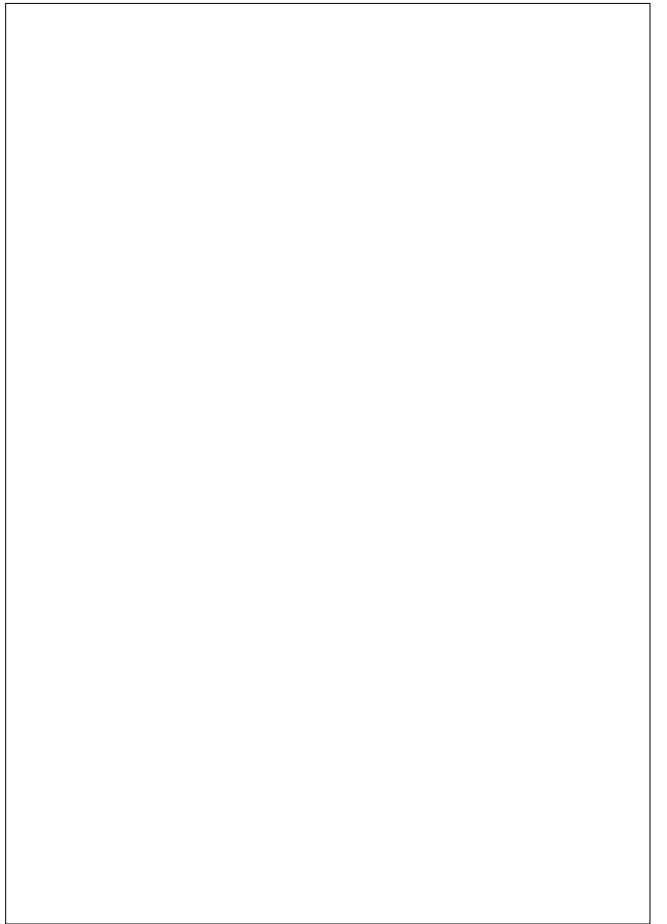
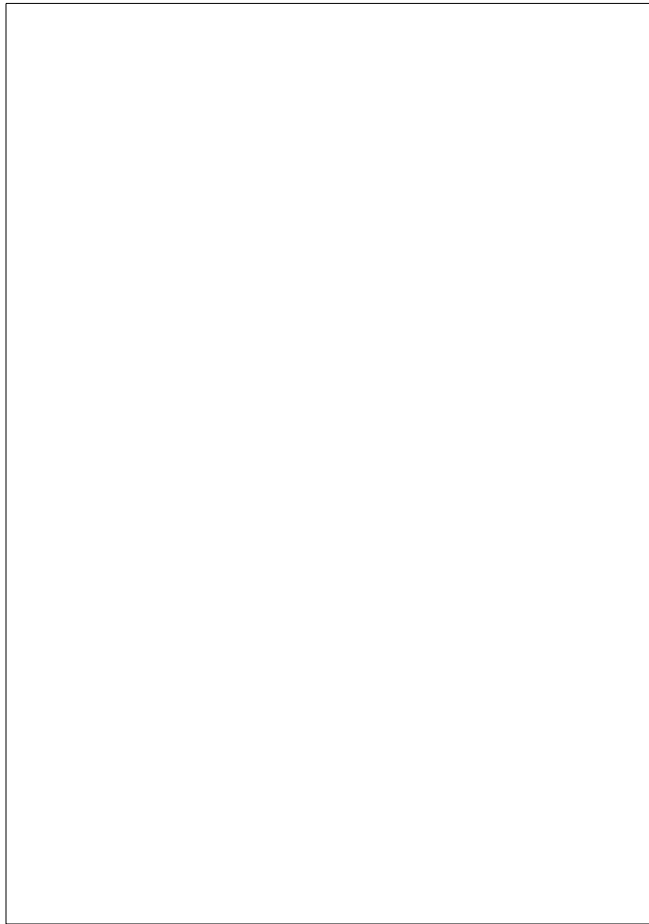
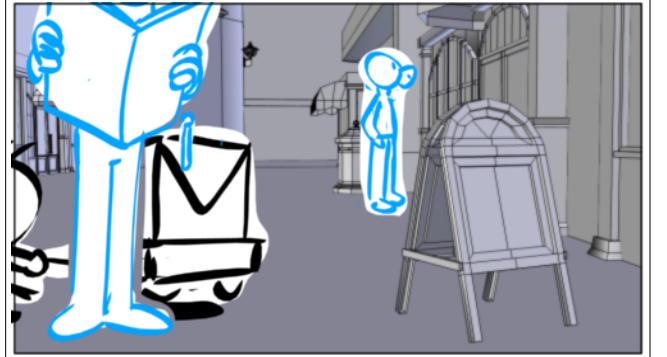
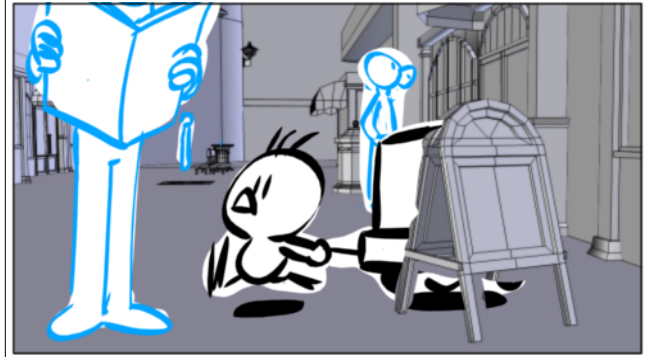
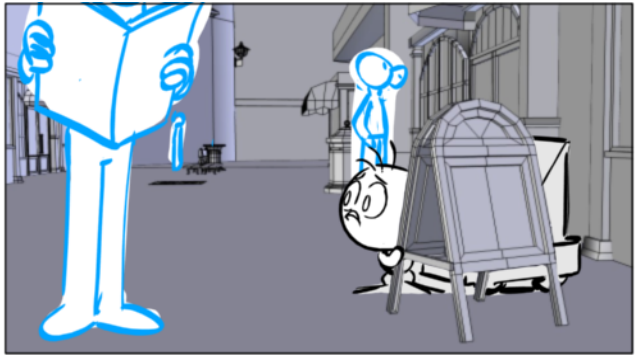

Scene	Duration	Panel	Duration
070	09:04	15	00:18

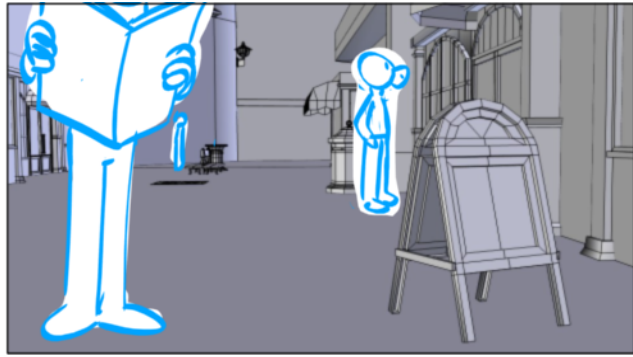

Scene	Duration	Panel	Duration
071	05:03	1	00:09

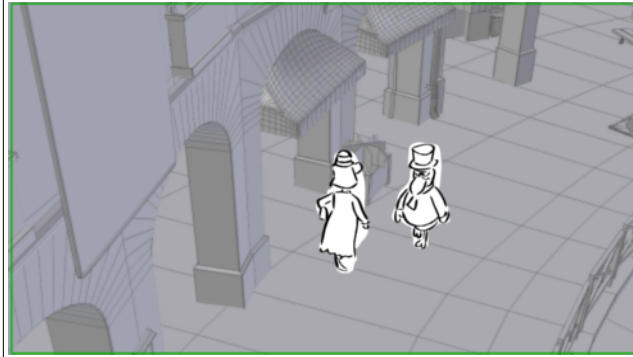

Scene	Duration	Panel	Duration
071	05:03	2	00:24

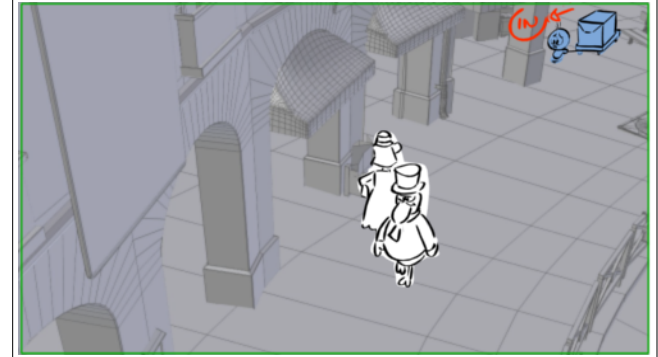

Action Notes
 EXT. ? INT JOUR / PLACE HAUTE - MAGASIN
 PAPERAZZI



Scene	Duration	Panel	Duration
071	05:03	3	00:22

Scene	Duration	Panel	Duration
071	05:03	4	00:24

Scene	Duration	Panel	Duration
071	05:03	5	01:01

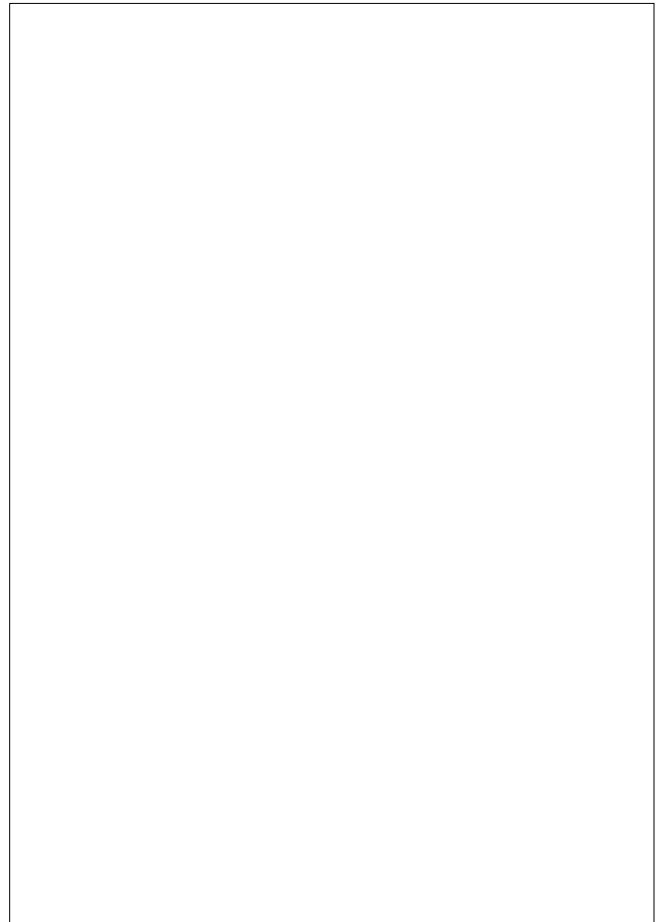
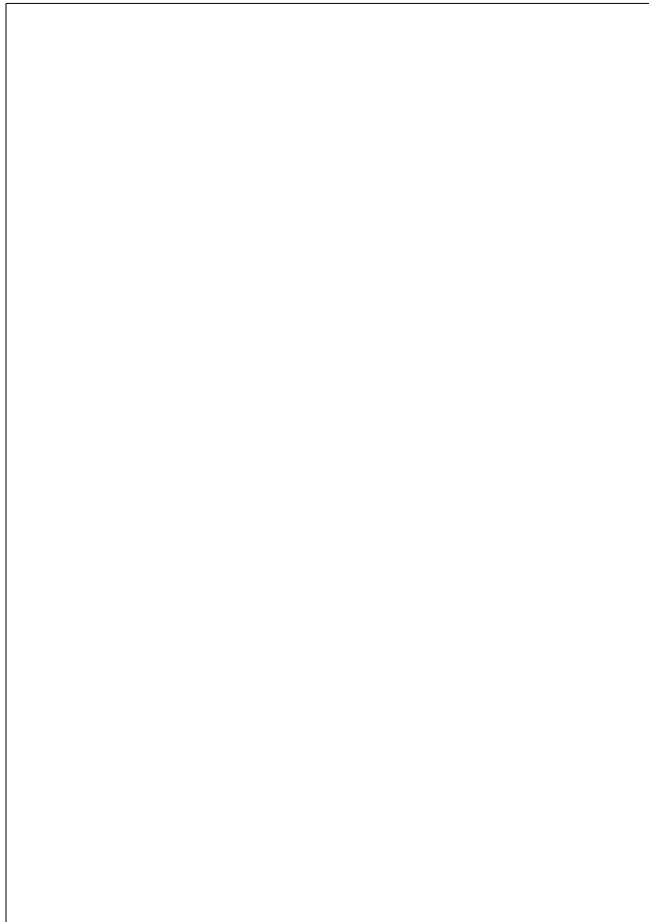
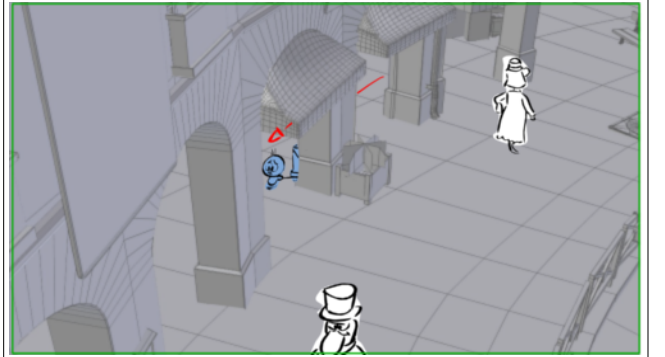



Scene	Duration	Panel	Duration
071	05:03	6	00:23

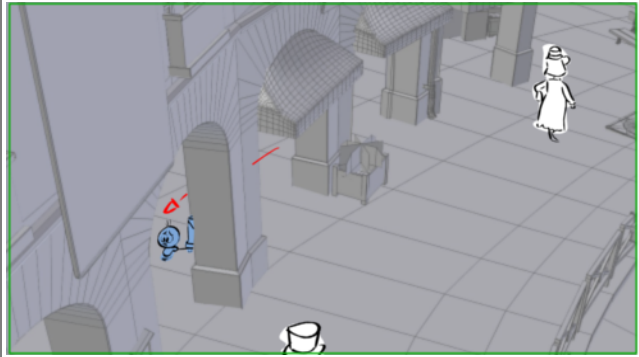

Scene	Duration	Panel	Duration
072	03:07	1	00:10

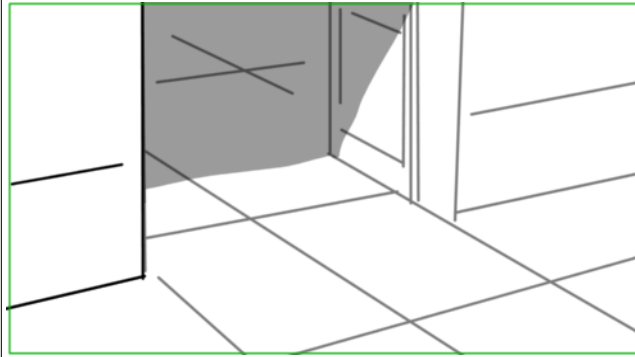

Scene	Duration	Panel	Duration
072	03:07	2	01:06

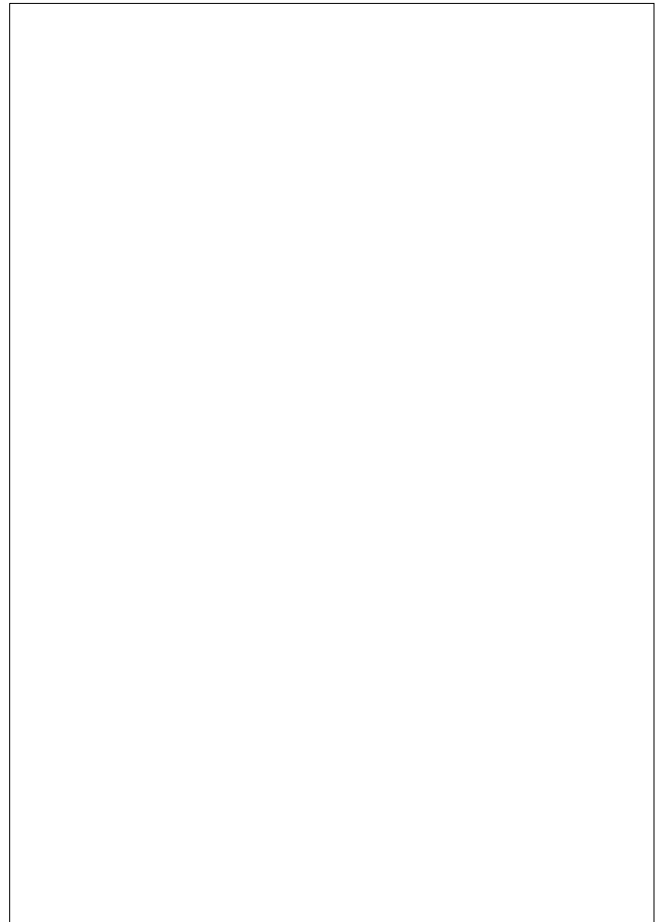
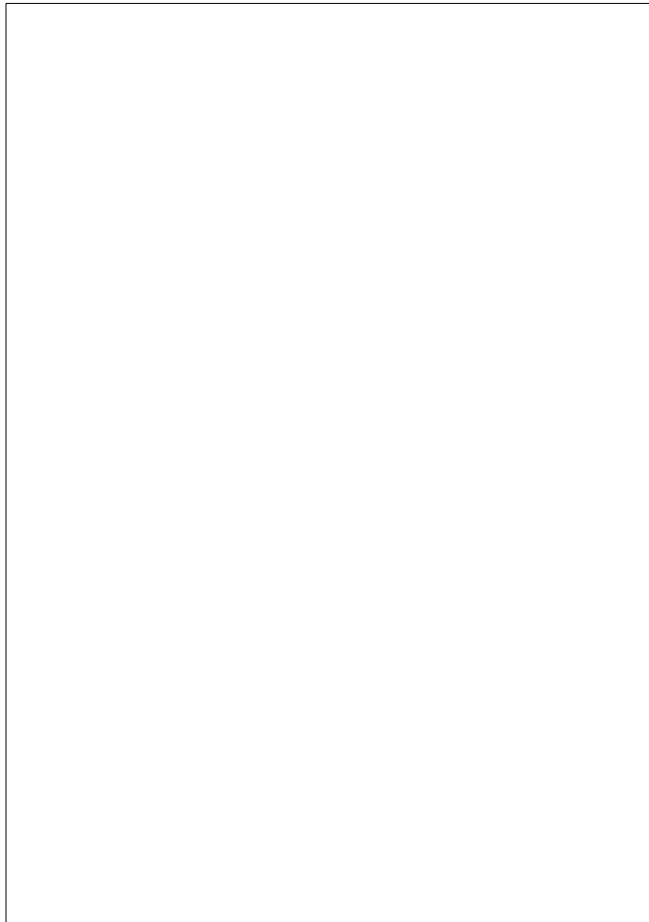
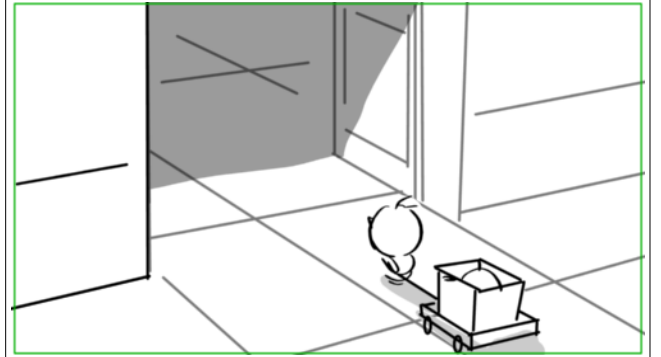

Scene	Duration	Panel	Duration
072	03:07	3	01:03

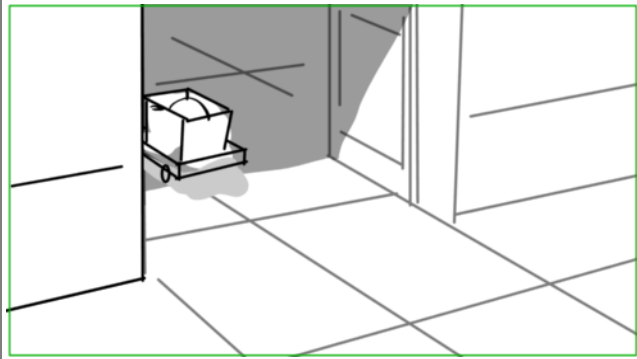

Scene	Duration	Panel	Duration
072	03:07	4	00:13

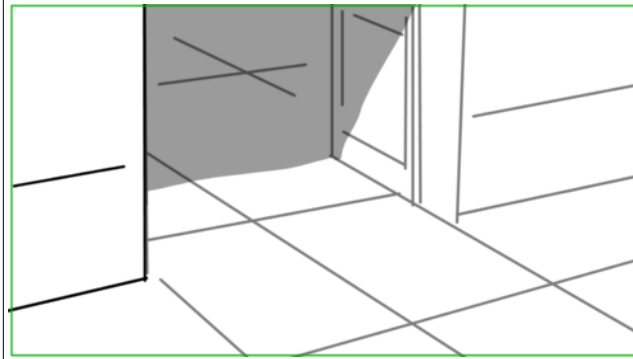

Scene	Duration	Panel	Duration
073	04:04	1	01:00



Dialogue

41. MAGNONI (désolé)
< SOUPIR >

Action Notes

4. GRAND MAGASIN PAPERAZZI. EXT PUIS INT/JOUR
Quantité de flcanos de solvants ménagers, brosse, cirage sont éparpillés au sol

Scene	Duration	Panel	Duration
073	04:04	2	02:04



Dialogue

41. MAGNONI (désolé)
Je suis confus Caliméro,

Action Notes

PAN UP révélant Magnoni qui frotte désespérément la coquille de Caliméro

Scene	Duration	Panel	Duration
073	04:04	3	01:00



Dialogue

41. MAGNONI (désolé)
je n'arrive pas à enlever cette peinture.

Scene	Duration	Panel	Duration
074	07:18	1	01:00

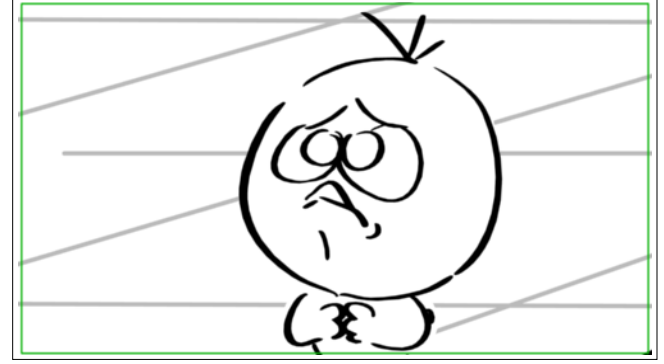

Dialogue

41. MAGNONI (désolé)
Il va falloir trouver une autre solution?

Scene	Duration	Panel	Duration
074	07:18	2	00:08

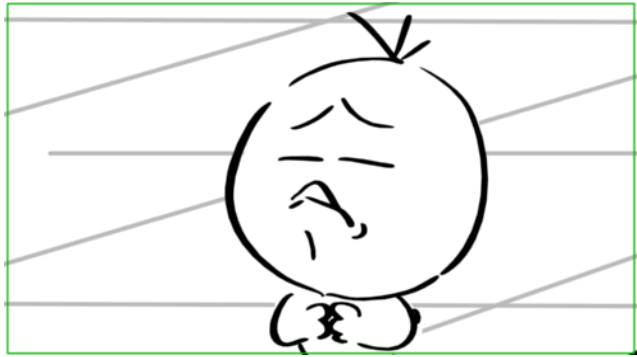
**Dialogue**

41. MAGNONI (désolé)
Il va falloir trouver une autre
solution?

Scene	Duration	Panel	Duration
074	07:18	3	01:00

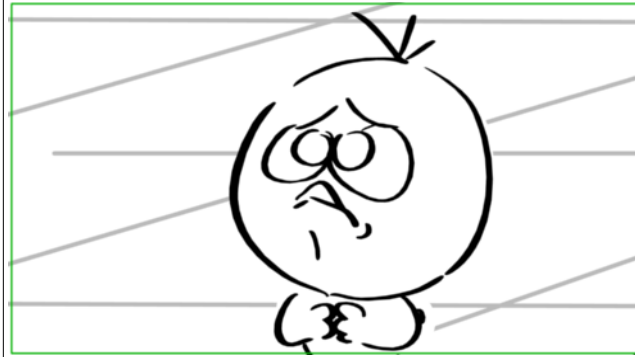
**Dialogue**

41. MAGNONI (désolé)
Il va falloir trouver une autre
solution?

Scene	Duration	Panel	Duration
074	07:18	4	01:00

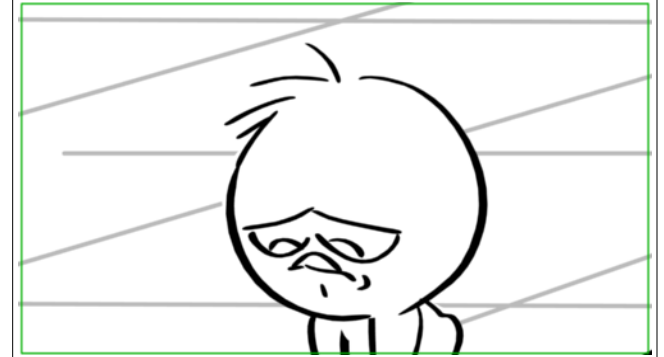
**Dialogue**

41. MAGNONI (désolé)
Il va falloir trouver une autre
solution?

Scene	Duration	Panel	Duration
074	07:18	5	02:18

Scene	Duration	Panel	Duration
074	07:18	6	00:17

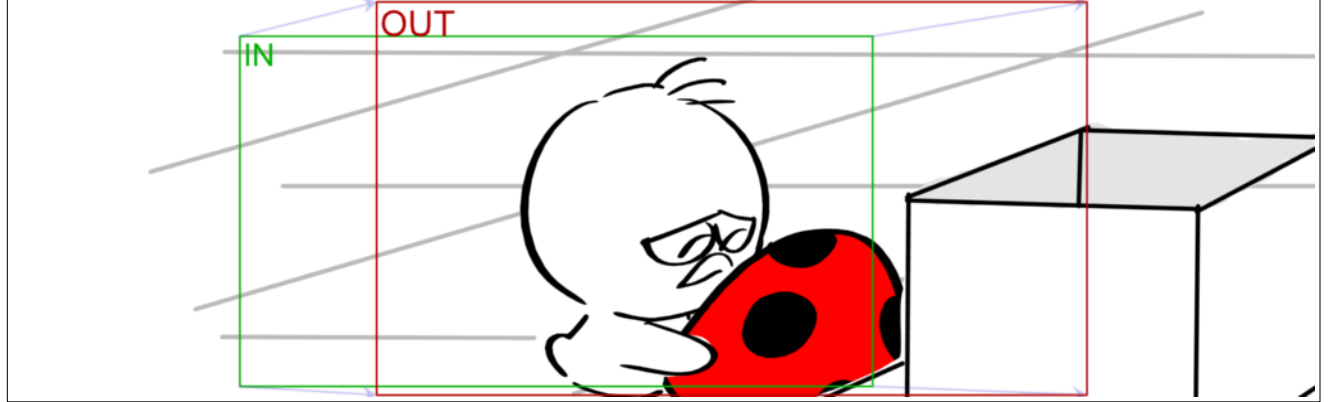

Dialogue
 42. CALIMERO (petite voix, abattu)
 Merci quand même, Monsieur Magnoni?

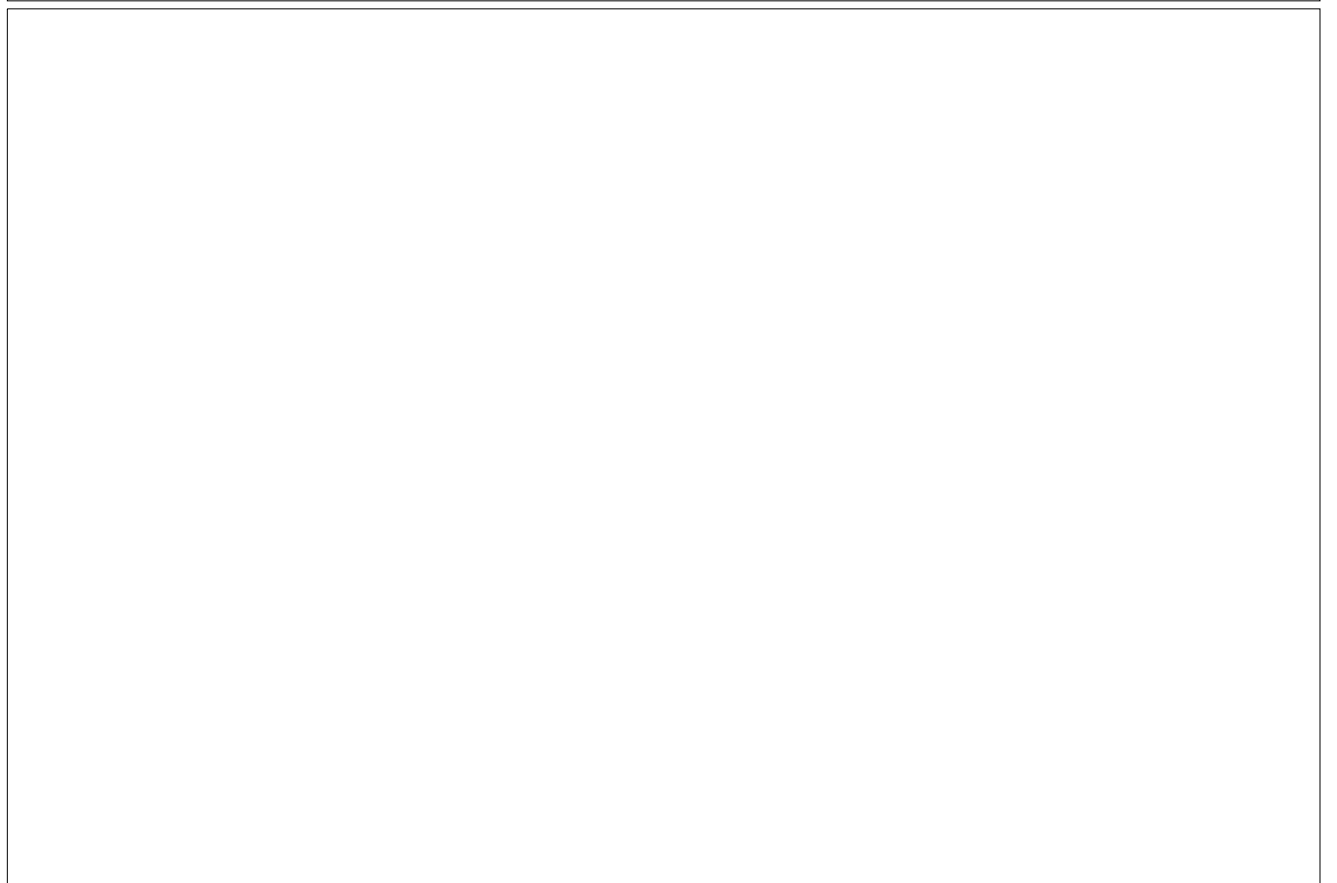



Scene	Duration	Panel	Duration
074	07:18	7	00:12

NO PANEL

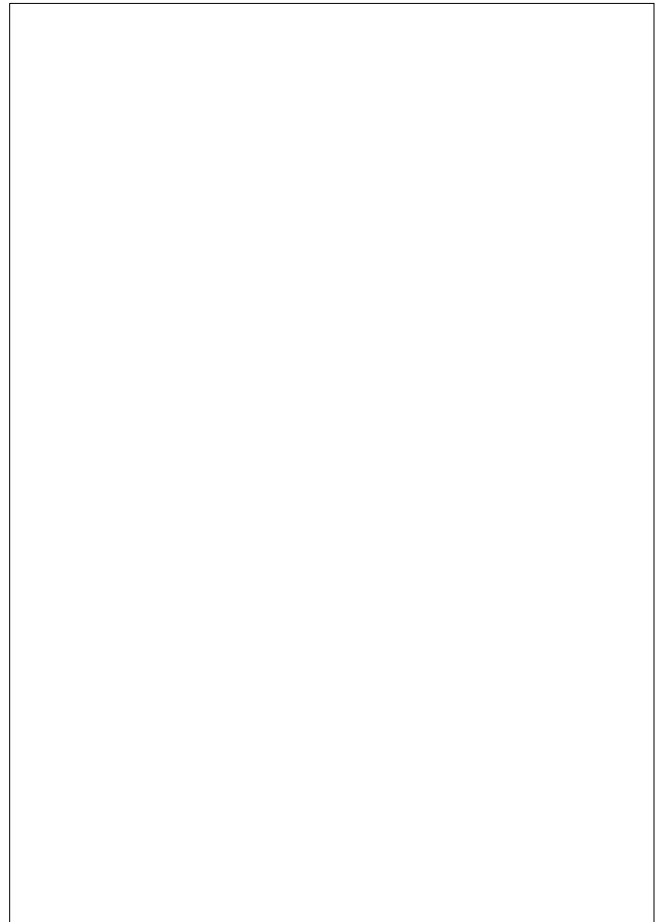
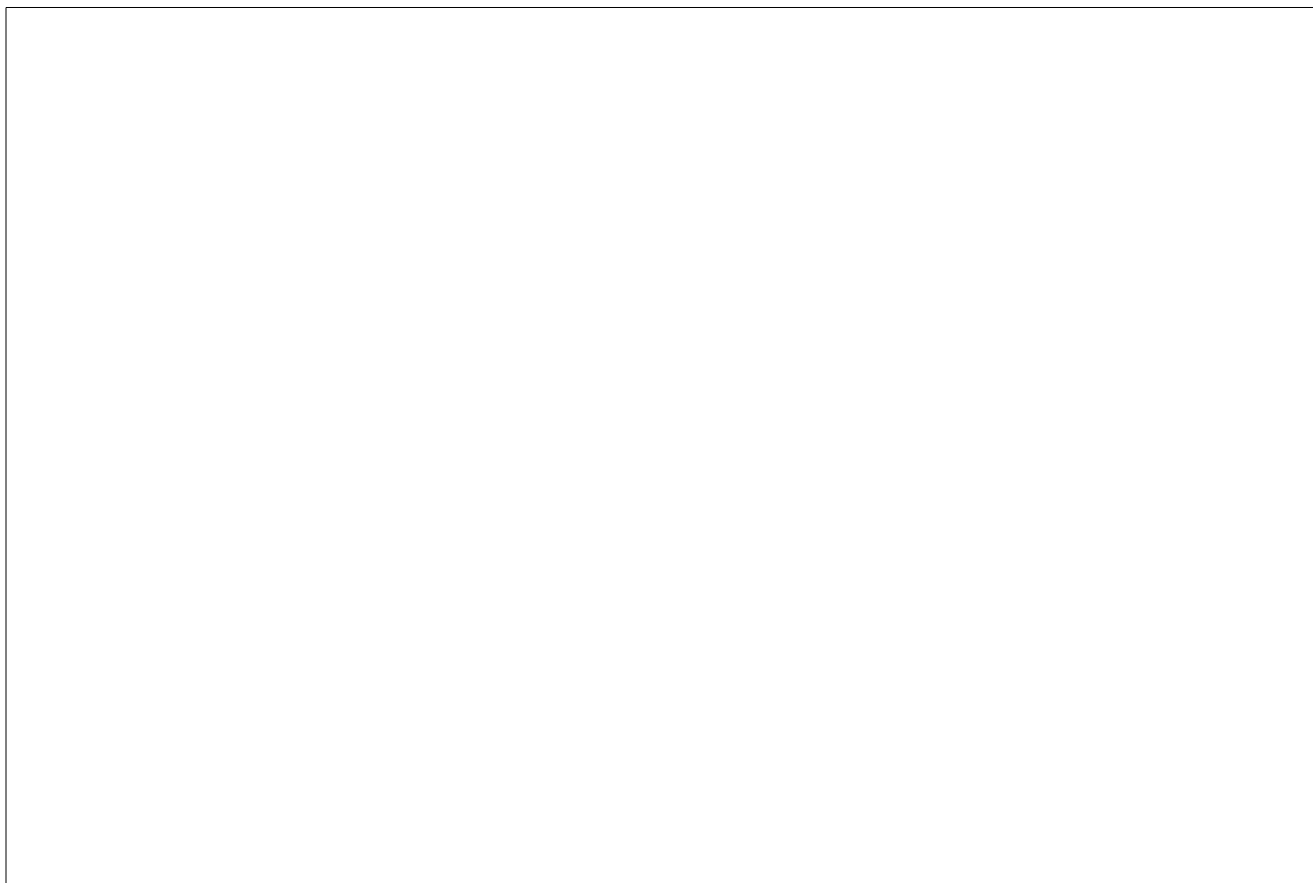
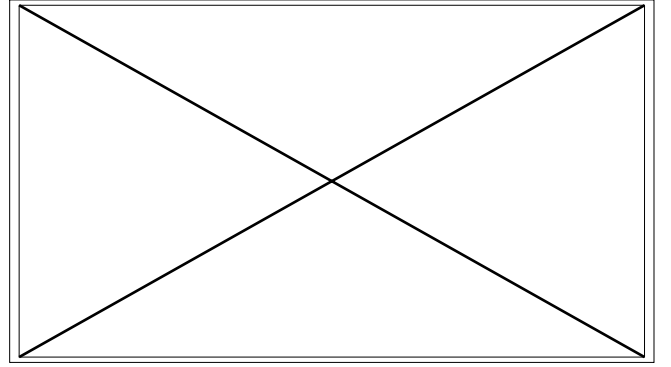
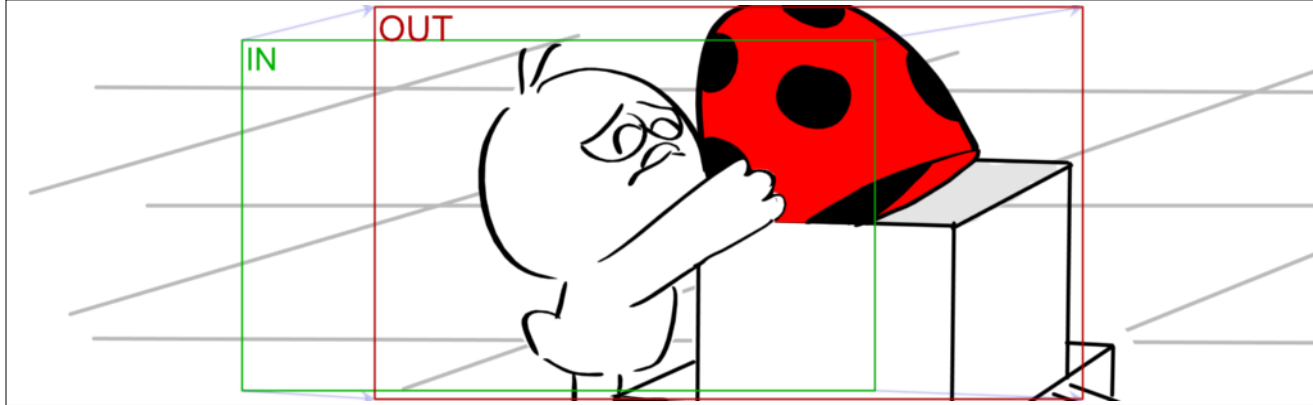

Scene	Duration	Panel	Duration
074	07:18	8	00:13



Scene	Duration	Panel	Duration
075	06:15	1	00:11

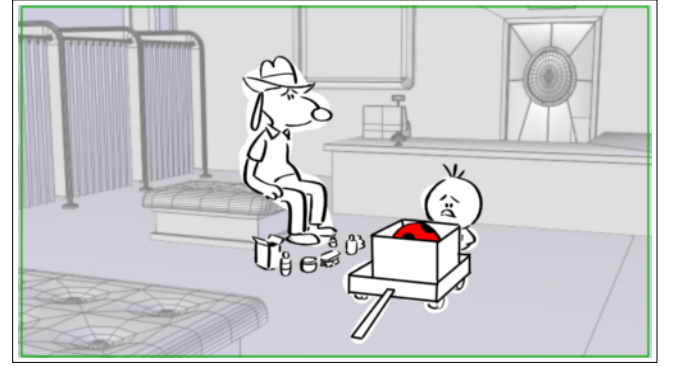

Scene	Duration	Panel	Duration
075	06:15	2	00:08

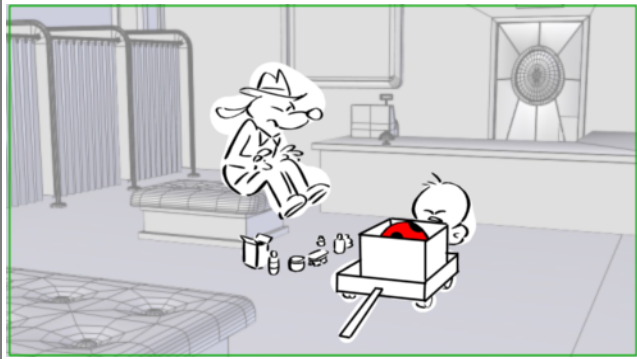

Dialogue
 43. AMBROGIO (OFF)
 MAGNONIIIIIIIIII !

Scene	Duration	Panel	Duration
075	06:15	3	00:17

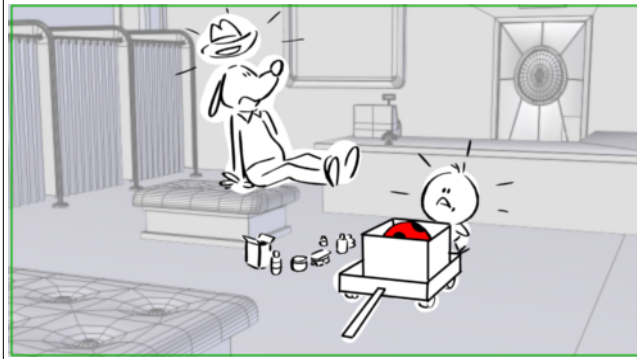

Dialogue
 43. AMBROGIO (OFF)
 MAGNONIIIIIIIIII !

Scene	Duration	Panel	Duration
075	06:15	4	01:00

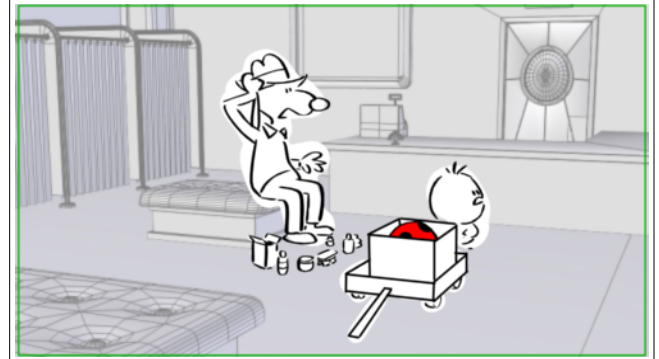

Dialogue
 44. MAGNONI (gêné)
 Houlà, je vais devoir y aller!

Scene	Duration	Panel	Duration
075	06:15	5	01:00

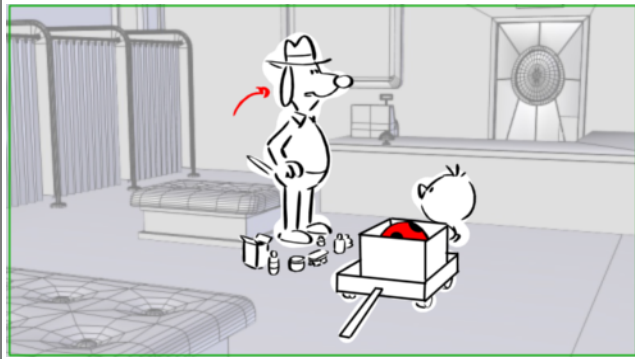

Dialogue

44. MAGNONI (gêné)
Euh?

Scene	Duration	Panel	Duration
075	06:15	6	02:15

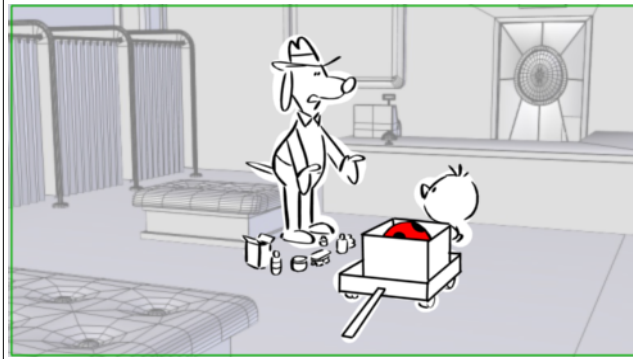

Dialogue

44. MAGNONI (gêné)
peut-être que quelqu'un qui s'y connaît
mieux en peinture pourrait t'aider?

Scene	Duration	Panel	Duration
075	06:15	7	00:14

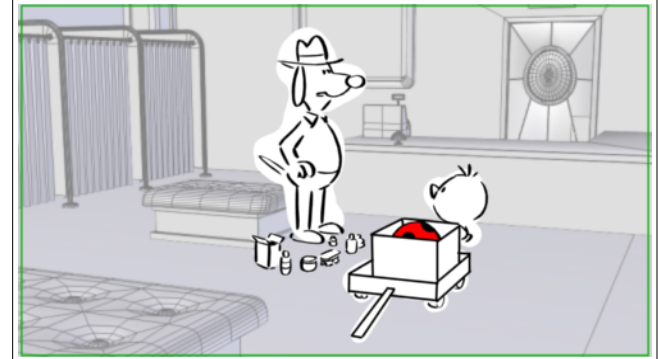

Dialogue

44. MAGNONI (gêné)
peut-être que quelqu'un qui s'y connaît
mieux en peinture pourrait t'aider?

Scene	Duration	Panel	Duration
076	04:00	1	00:17

Scene	Duration	Panel	Duration
076	04:00	2	01:00

Scene	Duration	Panel	Duration
076	04:00	3	00:08

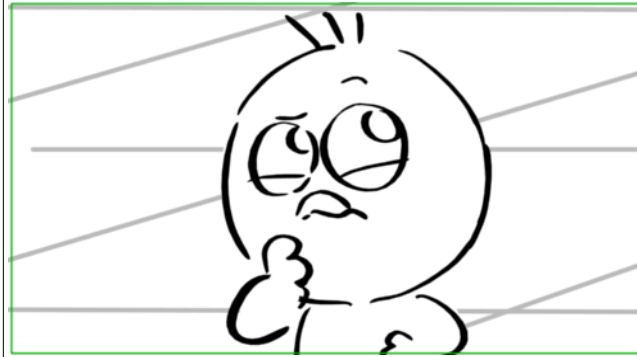
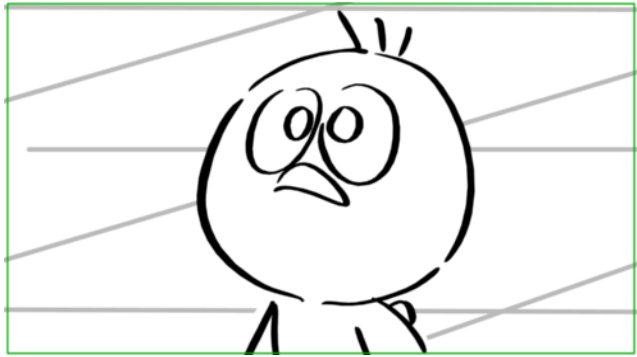

Dialogue

45. CALIMERO (réfléchissant puis combattif)
Mmhh?

Scene	Duration	Panel	Duration
076	04:00	4	01:00

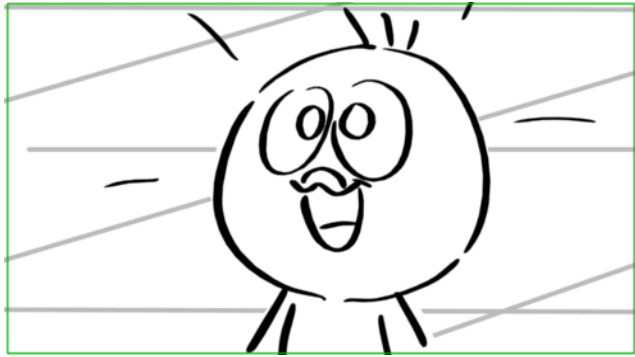
**Dialogue**

45. CALIMERO (réfléchissant puis combattif)
Mais bien sûr !

Scene	Duration	Panel	Duration
076	04:00	5	01:00

**Dialogue**

45. CALIMERO (réfléchissant puis combattif)
Jojo !

Scene	Duration	Panel	Duration
077	09:20	1	00:09

**Dialogue**

45. CALIMERO (réfléchissant puis combattif)
Il est peintre, il doit certainement savoir comment on enlève les taches de peinture !

Scene	Duration	Panel	Duration
077	09:20	2	00:09

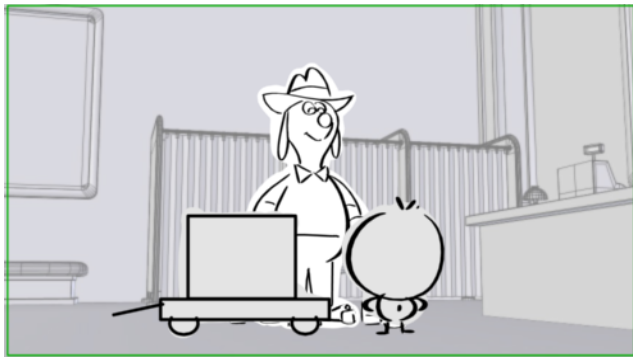
**Dialogue**

45. CALIMERO (réfléchissant puis combattif)

Il est peintre, il doit certainement savoir comment on enlève les taches de peinture !

Scene	Duration	Panel	Duration
077	09:20	3	00:09

**Dialogue**

45. CALIMERO (réfléchissant puis combattif)

Il est peintre, il doit certainement savoir comment on enlève les taches de peinture !

Scene	Duration	Panel	Duration
077	09:20	4	00:09

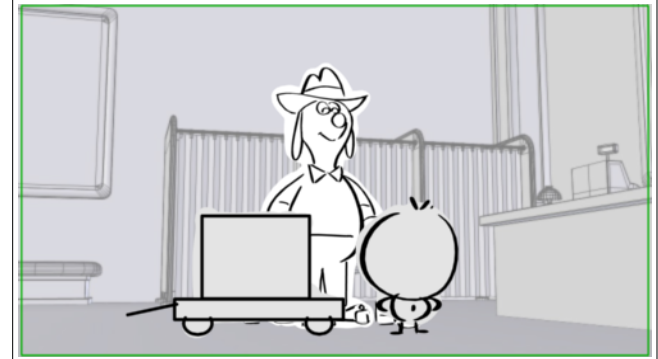
**Dialogue**

45. CALIMERO (réfléchissant puis combattif)

Il est peintre, il doit certainement savoir comment on enlève les taches de peinture !

Scene	Duration	Panel	Duration
077	09:20	5	00:09

**Dialogue**

45. CALIMERO (réfléchissant puis combattif)

Il est peintre, il doit certainement savoir comment on enlève les taches de peinture !

Scene	Duration	Panel	Duration
077	09:20	6	00:09

**Dialogue**

45. CALIMERO (réfléchissant puis combattif)

Il est peintre, il doit certainement savoir comment on enlève les taches de peinture !

Scene	Duration	Panel	Duration
077	09:20	7	00:09

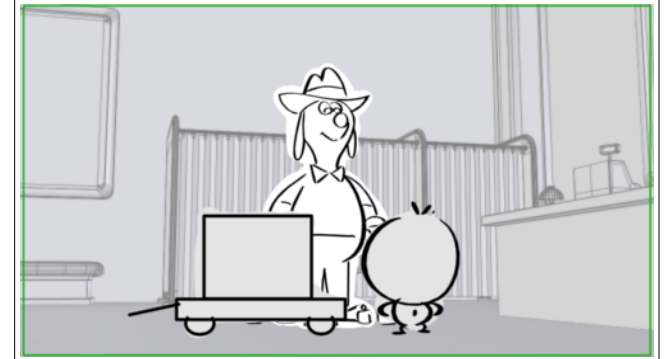
**Dialogue**

45. CALIMERO (réfléchissant puis combattif)

Il est peintre, il doit certainement savoir comment on enlève les taches de peinture !

Scene	Duration	Panel	Duration
077	09:20	8	00:09

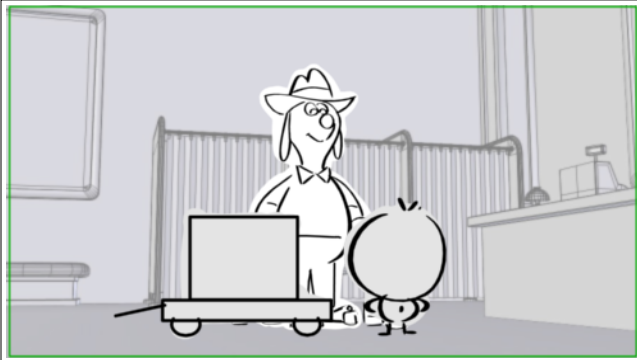

Dialogue

45. CALIMERO (réfléchissant puis combattif)
 Il est peintre, il doit certainement savoir comment on enlève les taches de peinture !

Scene	Duration	Panel	Duration
077	09:20	9	00:09

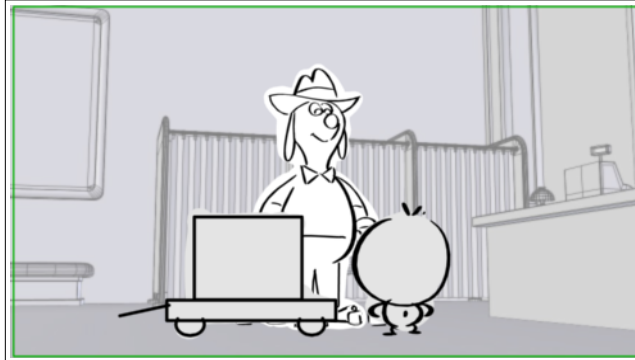

Dialogue

45. CALIMERO (réfléchissant puis combattif)
 Il est peintre, il doit certainement savoir comment on enlève les taches de peinture !

Scene	Duration	Panel	Duration
077	09:20	10	00:09

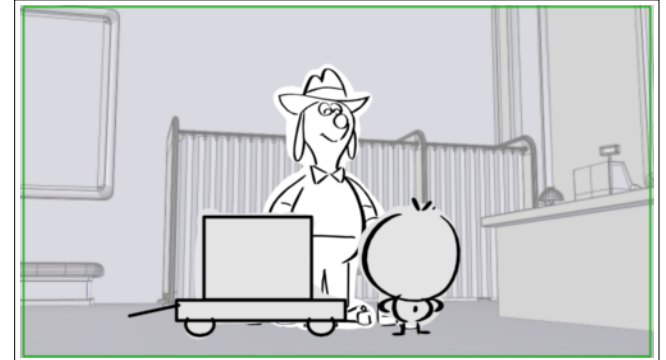

Dialogue

45. CALIMERO (réfléchissant puis combattif)
 Il est peintre, il doit certainement savoir comment on enlève les taches de peinture !

Scene	Duration	Panel	Duration
077	09:20	11	00:09

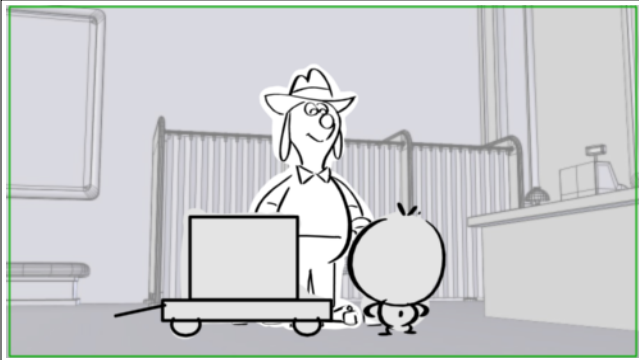

Dialogue
 45. CALIMERO (réfléchissant puis combattif)
 Il est peintre, il doit certainement savoir comment on enlève les taches de peinture !

Scene	Duration	Panel	Duration
077	09:20	12	00:15

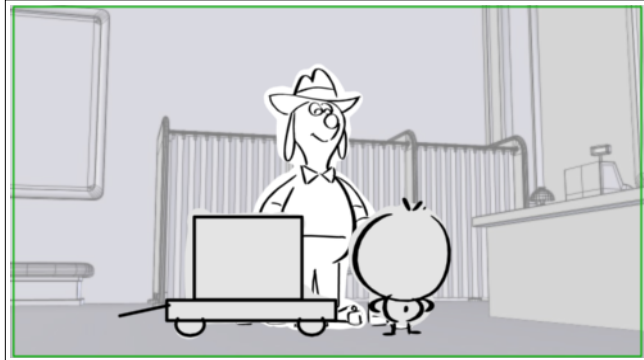

Dialogue
 45. CALIMERO (réfléchissant puis combattif)
 Il est peintre, il doit certainement savoir comment on enlève les taches de peinture !

Scene	Duration	Panel	Duration
077	09:20	13	01:00



Dialogue
 45. CALIMERO (réfléchissant puis combattif)
 Merci Monsieur Magnoni !



Scene	Duration	Panel	Duration
077	09:20	14	01:01

Scene	Duration	Panel	Duration
077	09:20	15	00:15

Scene	Duration	Panel	Duration
077	09:20	16	00:17

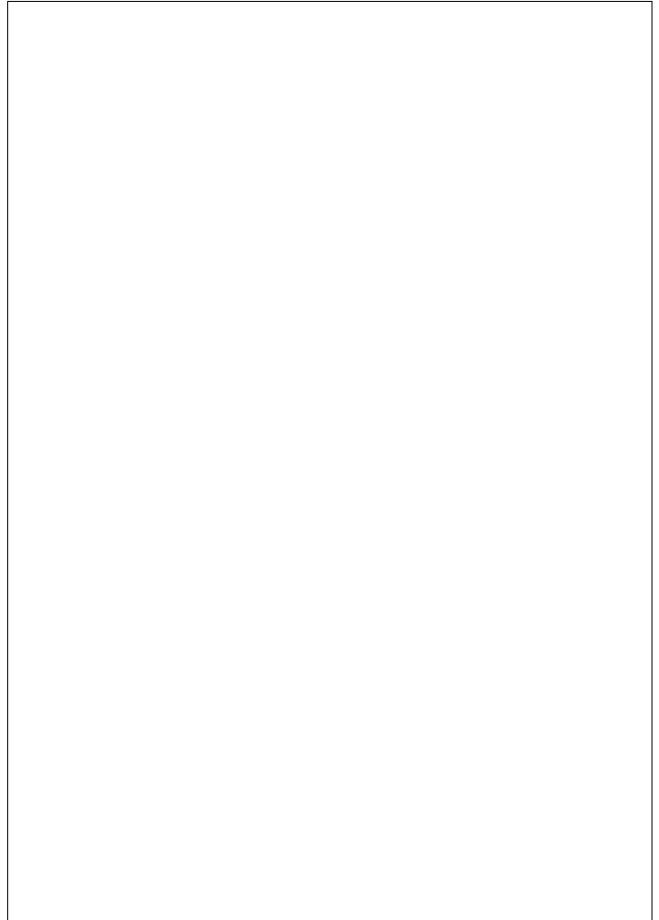
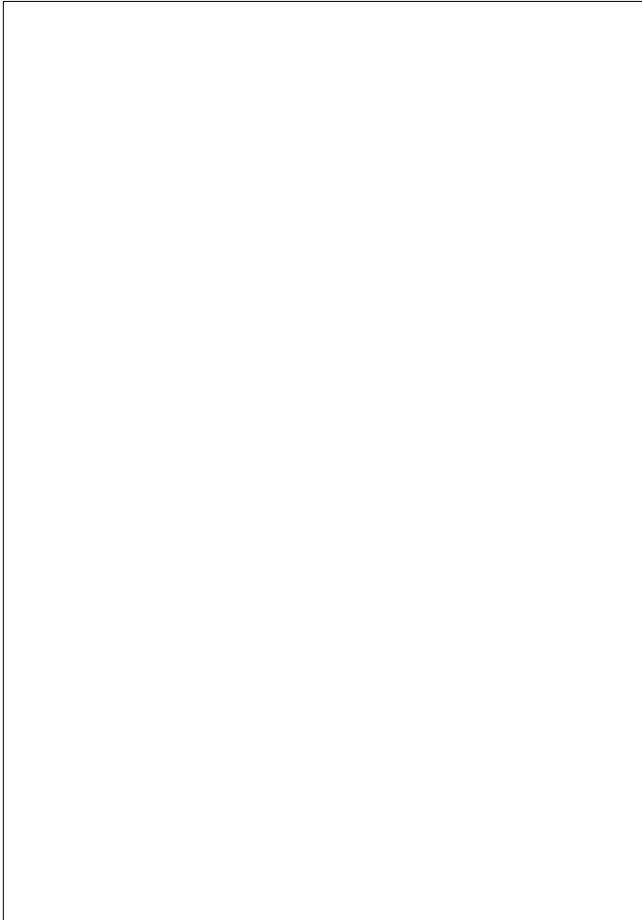
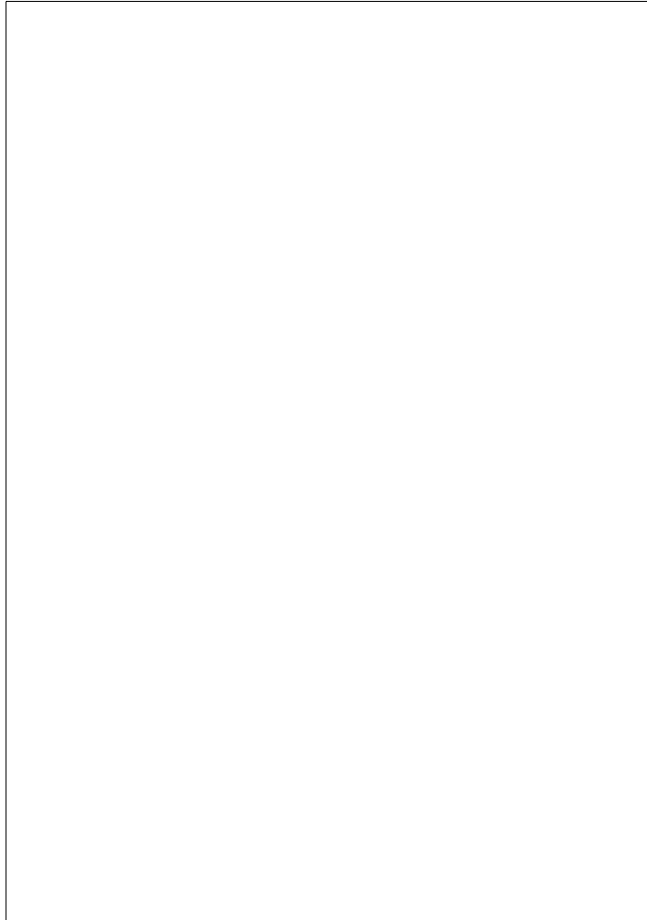



Scene	Duration	Panel	Duration
077	09:20	17	00:10



Scene	Duration	Panel	Duration
077	09:20	18	00:12



Scene	Duration	Panel	Duration
077	09:20	19	00:13

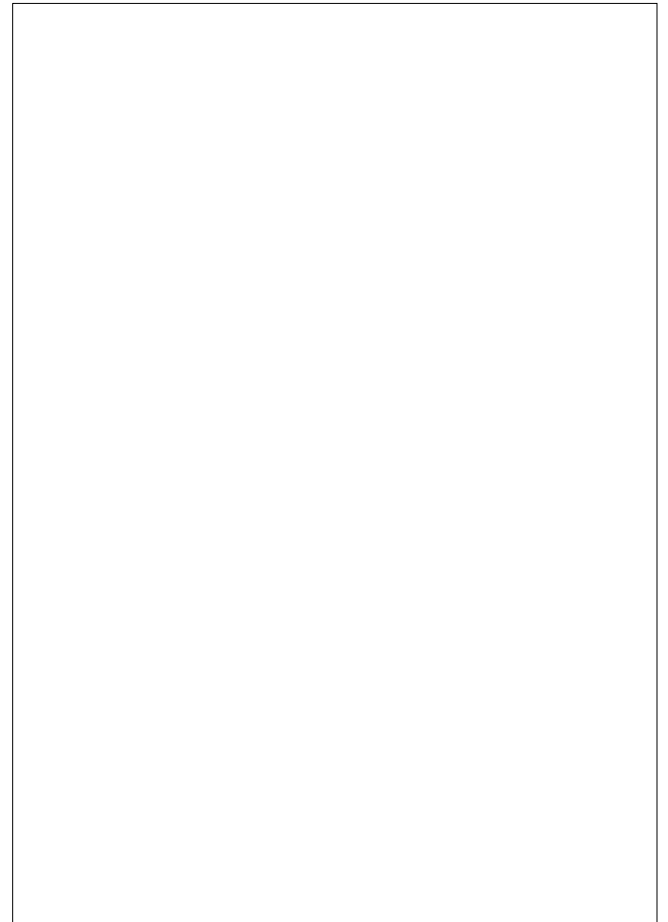
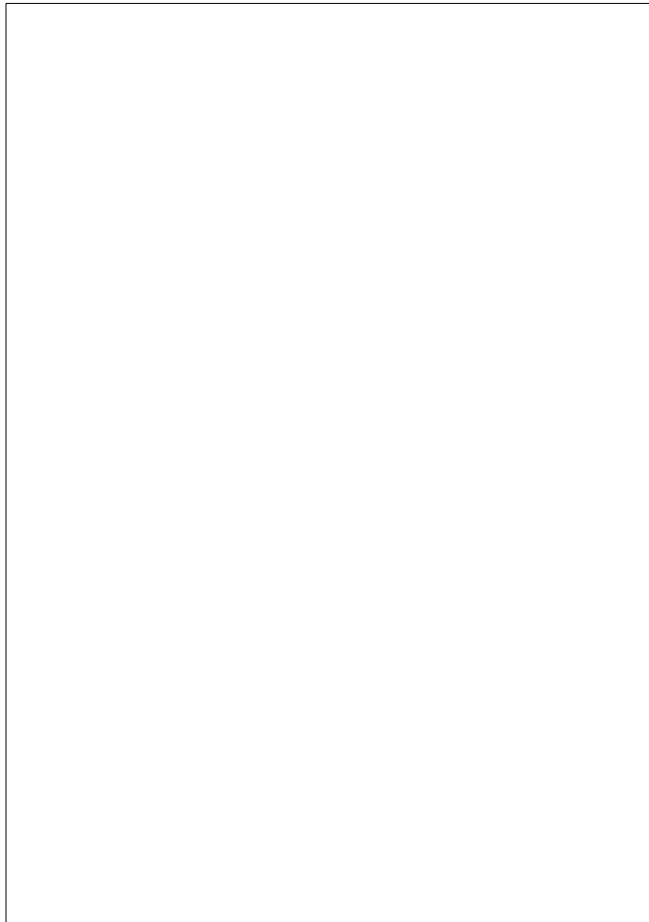
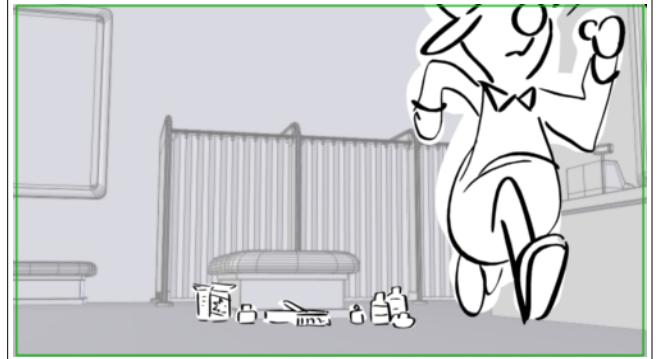



Scene	Duration	Panel	Duration
077	09:20	20	00:13

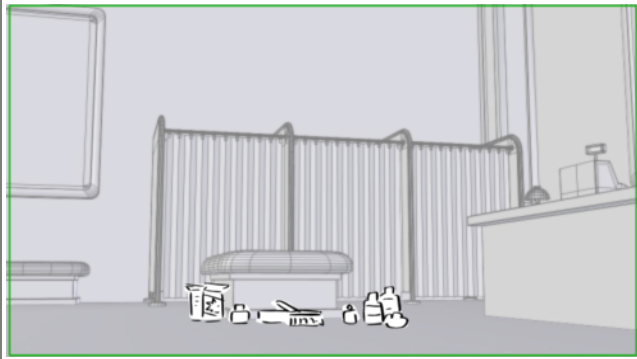

Scene	Duration	Panel	Duration
078	04:02	1	00:10

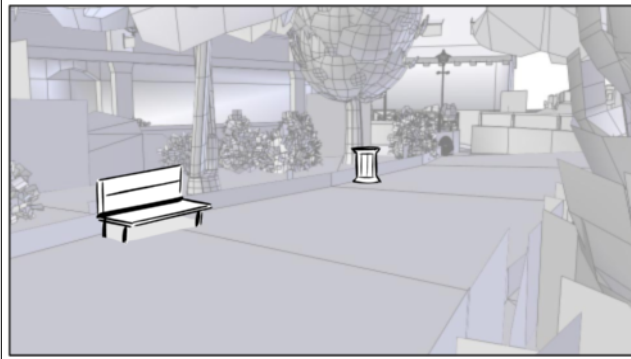

Action Notes

5. PARC. EXT/JOUR ? TEMPS GRIS

Scene	Duration	Panel	Duration
078	04:02	2	00:11

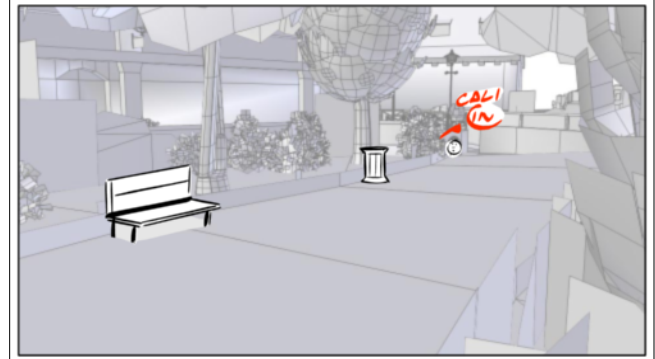

Action Notes

Calimero IN

Scene	Duration	Panel	Duration
078	04:02	3	00:14

Scene	Duration	Panel	Duration
078	04:02	4	00:12

Scene	Duration	Panel	Duration
078	04:02	5	00:14

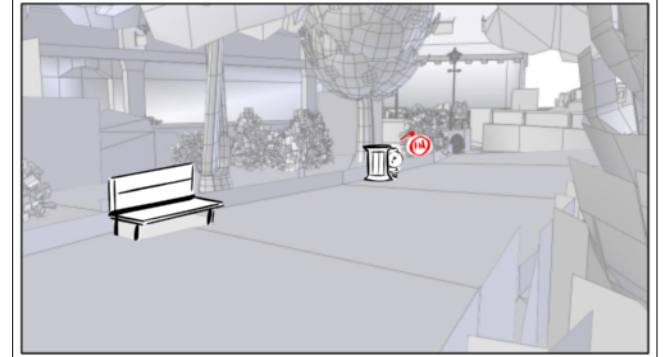
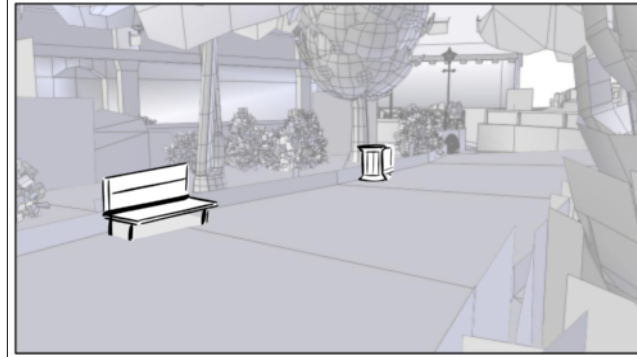
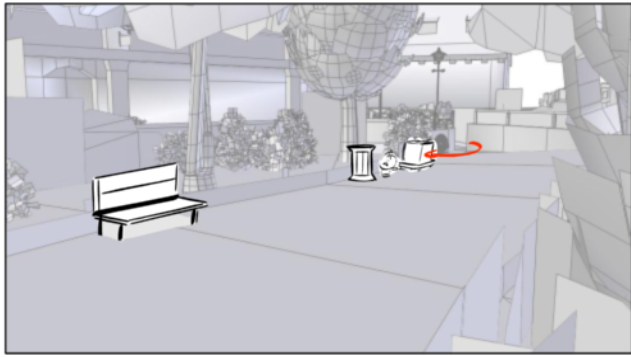

Action Notes

passant de cachette en cachette

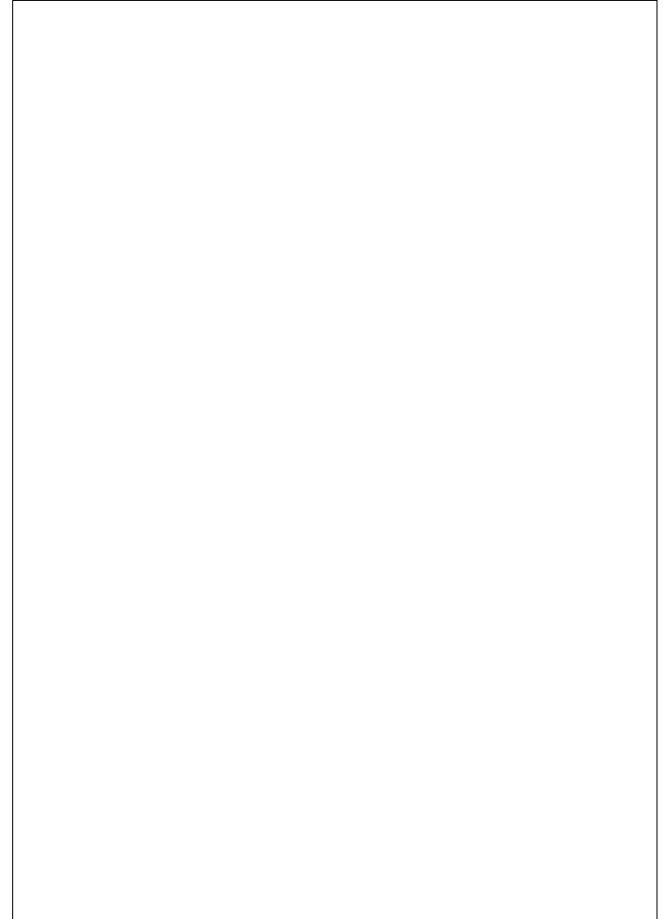
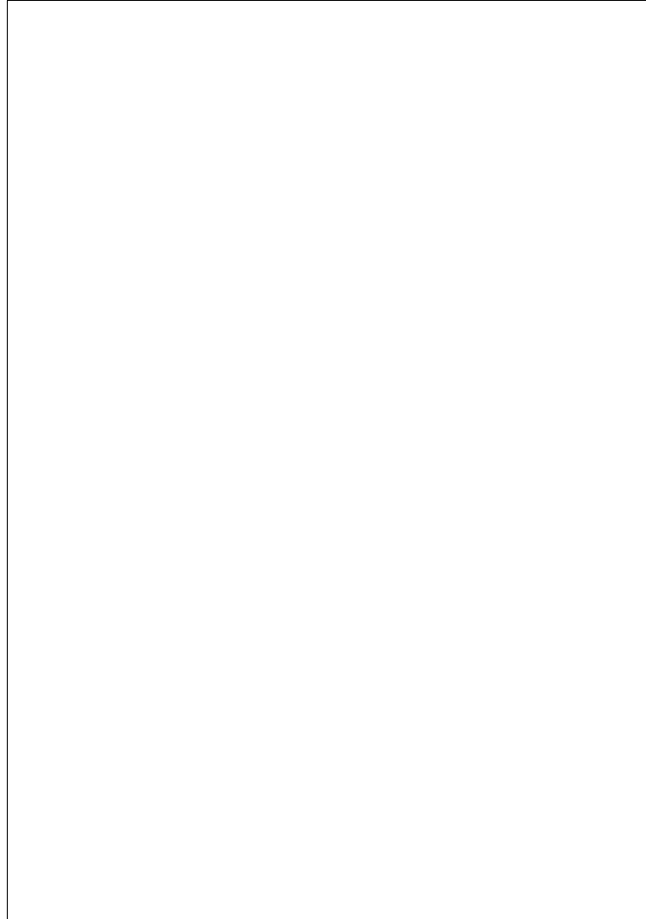



Scene	Duration	Panel	Duration
078	04:02	6	00:10

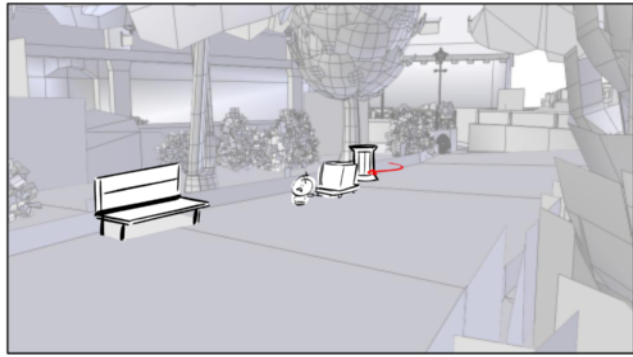

Scene	Duration	Panel	Duration
078	04:02	7	00:10

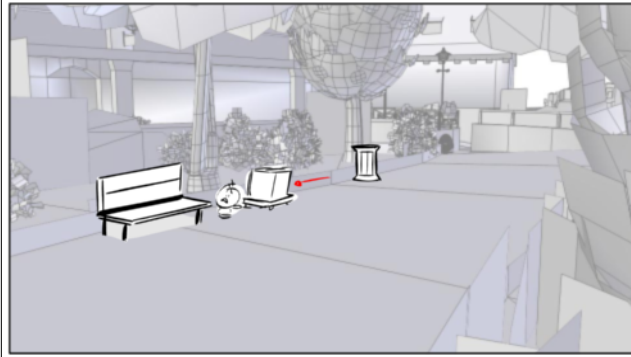

Scene	Duration	Panel	Duration
078	04:02	8	00:21

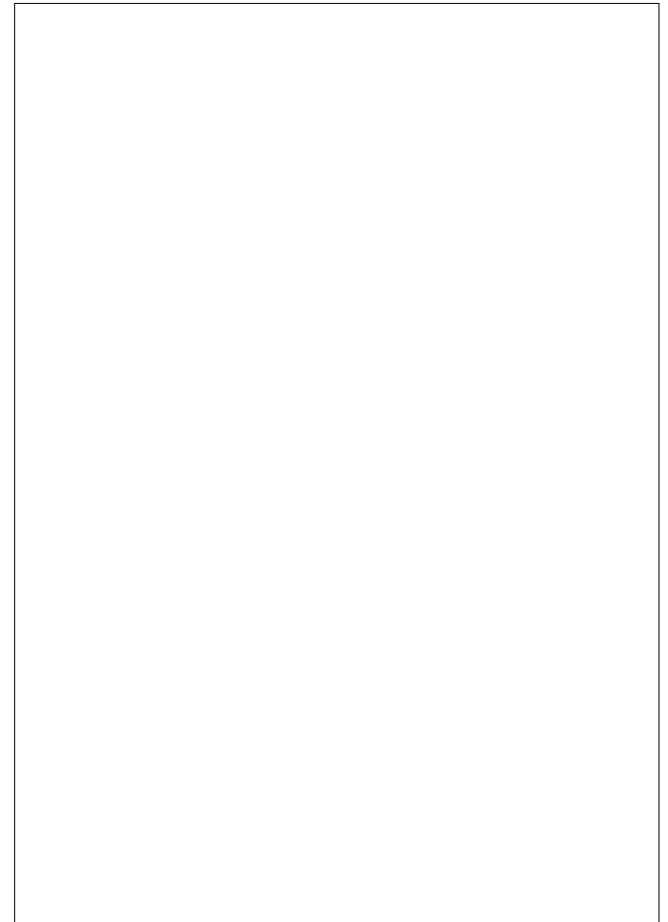
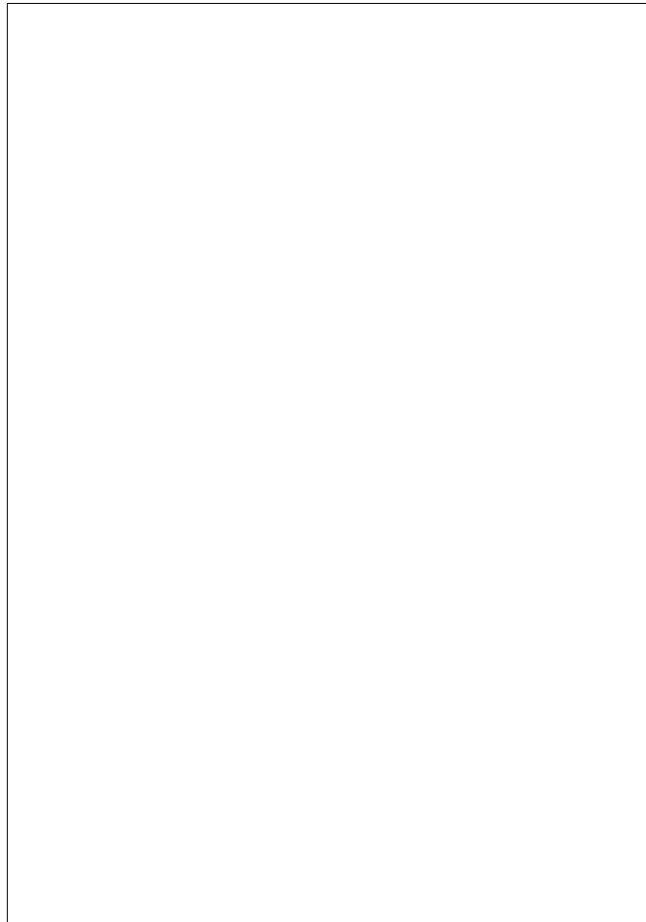
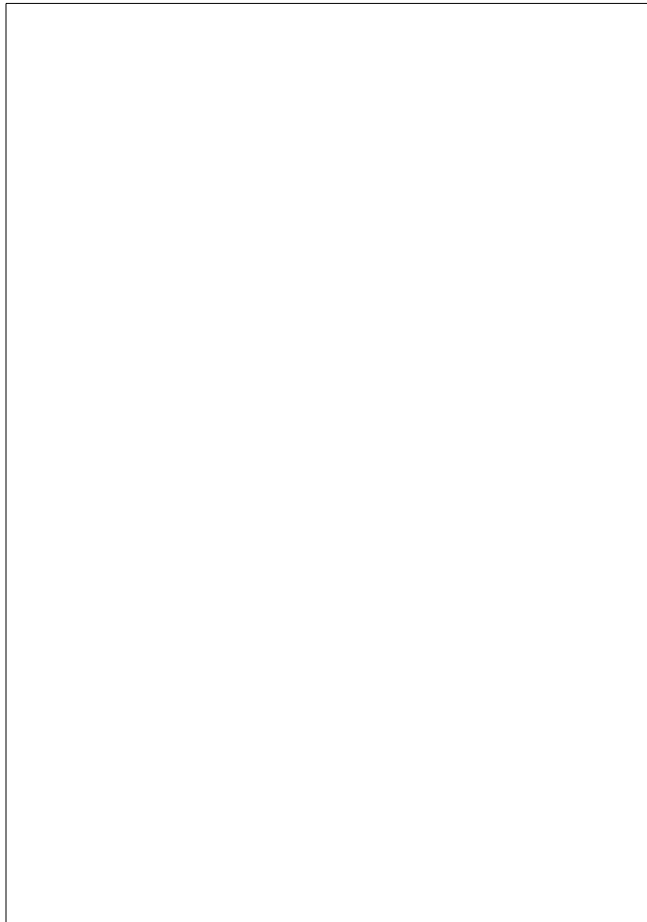
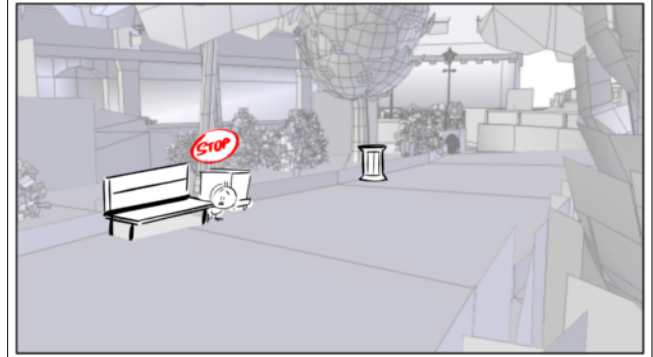



Scene	Duration	Panel	Duration
079	02:17	1	00:18

Scene	Duration	Panel	Duration
079	02:17	2	00:11

Scene	Duration	Panel	Duration
079	02:17	3	00:17

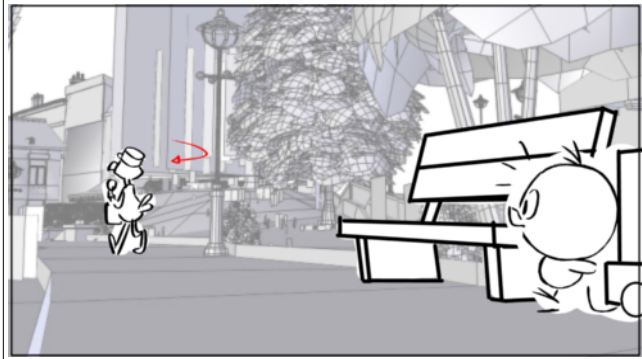

Action Notes

Jojo en train de peindre un lampadaire
un pot de peinture à la main

Scene	Duration	Panel	Duration
079	02:17	4	00:09

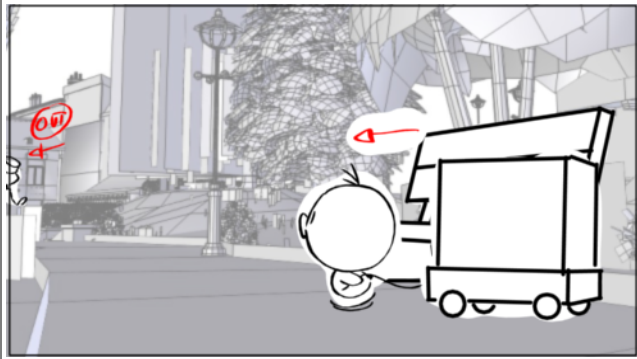

Scene	Duration	Panel	Duration
079	02:17	5	00:12

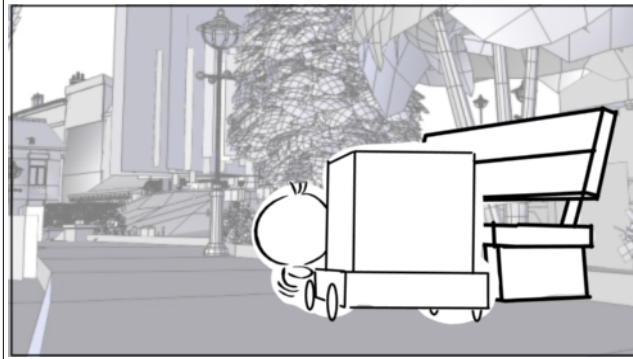

Scene	Duration	Panel	Duration
080	01:13	1	00:12

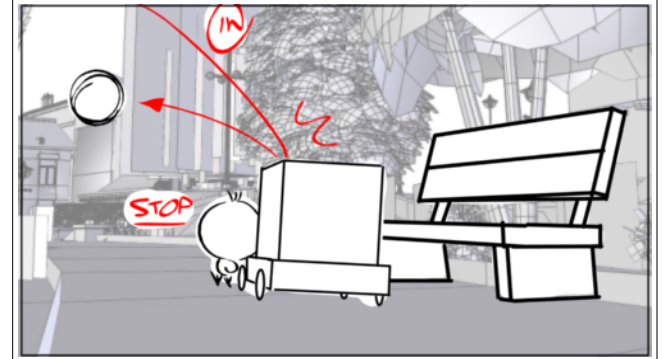

Action Notes

balle IN rebondit sur le carton

Scene	Duration	Panel	Duration
080	01:13	2	01:01

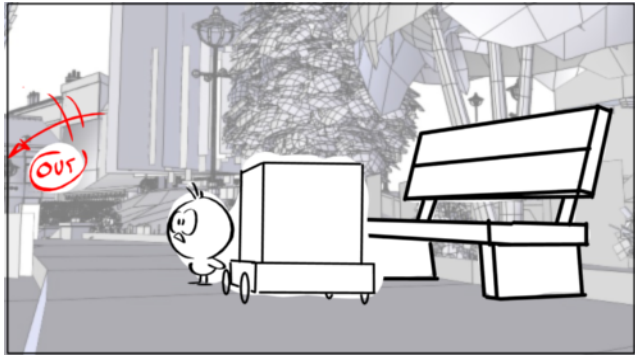

Scene	Duration	Panel	Duration
081	05:03	1	00:10

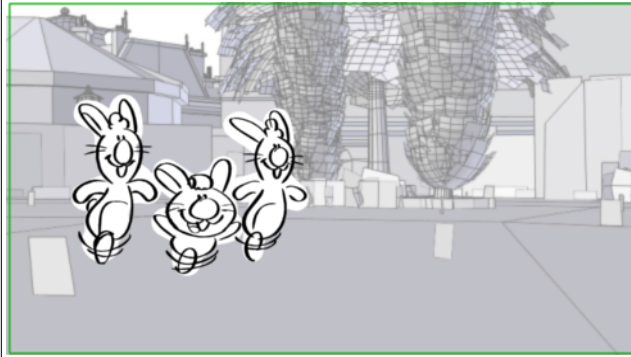

Scene	Duration	Panel	Duration
081	05:03	2	00:12

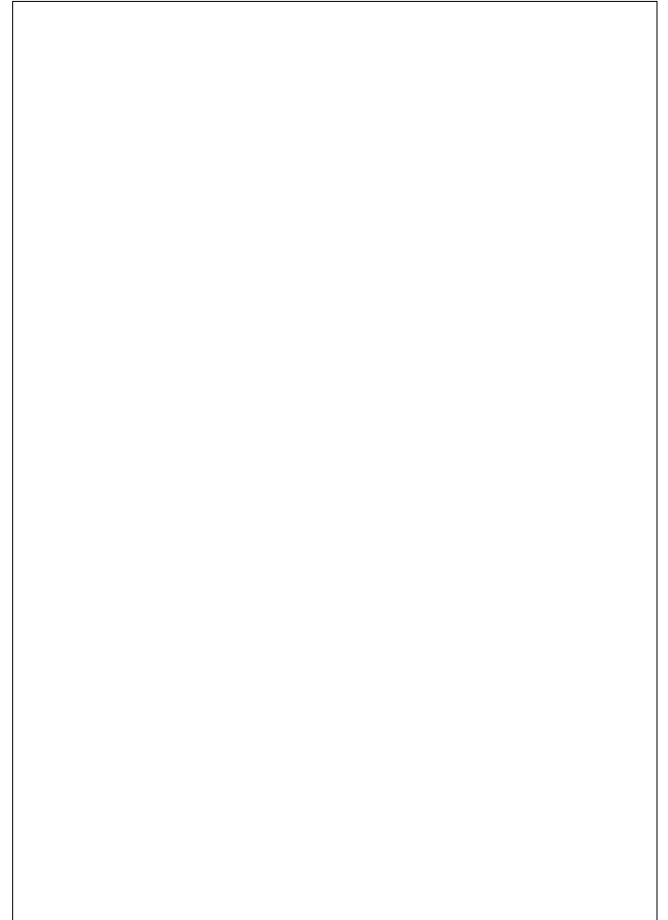
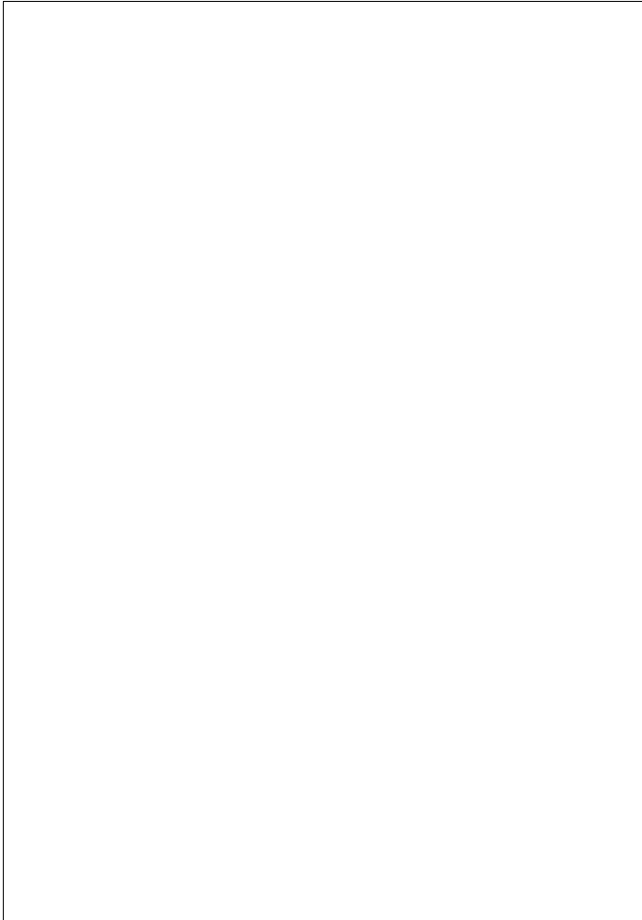
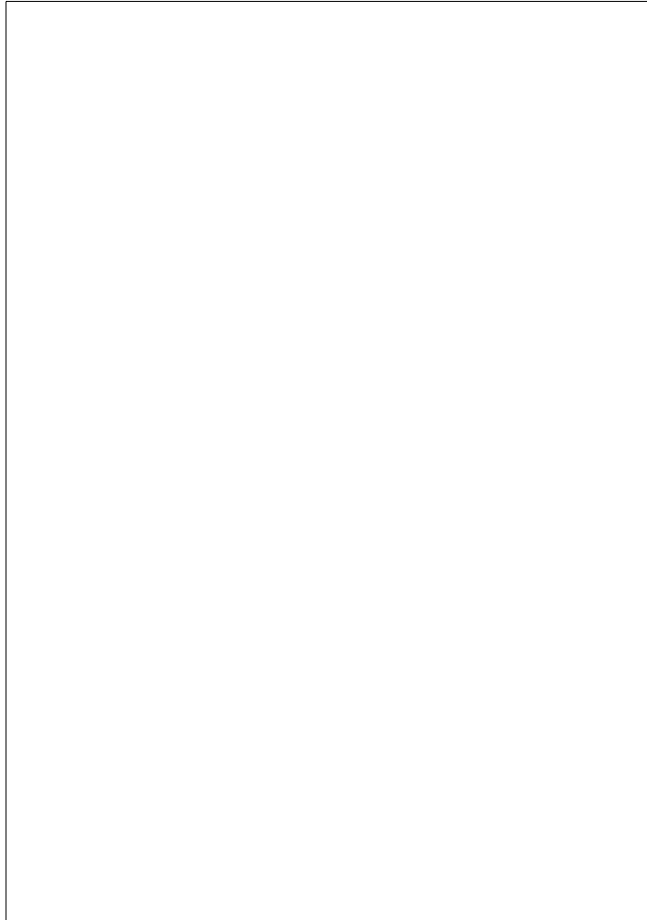
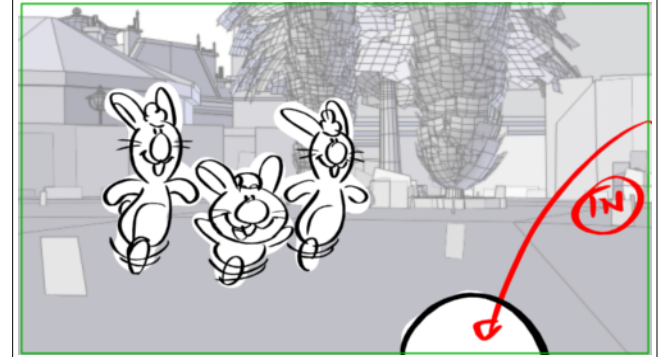

Scene	Duration	Panel	Duration
081	05:03	3	00:11

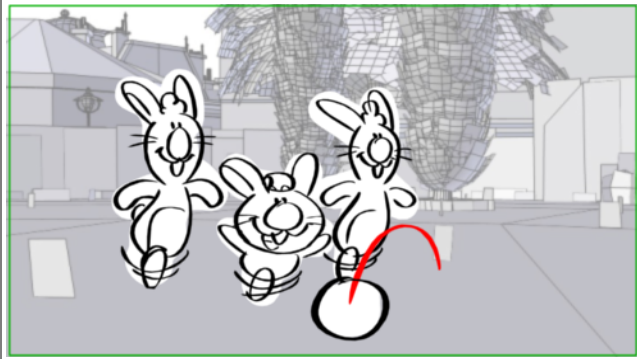

Scene	Duration	Panel	Duration
081	05:03	4	00:16

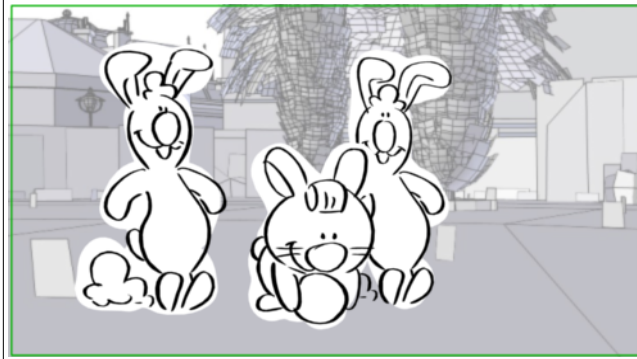

Scene	Duration	Panel	Duration
081	05:03	5	01:00

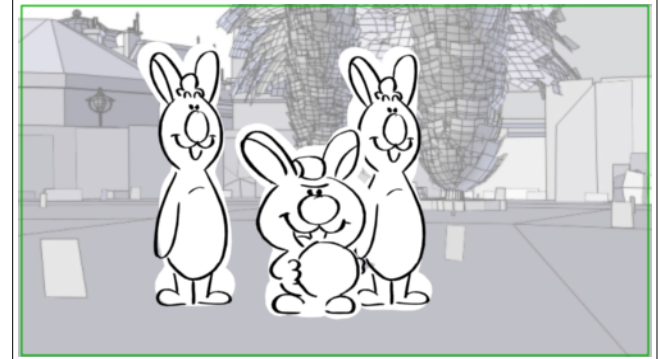

Dialogue

48. POT (moqueur)
 T'as pas peur d'attraper froid à la tête ?!

Scene	Duration	Panel	Duration
081	05:03	6	01:00

Scene	Duration	Panel	Duration
081	05:03	7	00:08

Scene	Duration	Panel	Duration
081	05:03	8	00:08

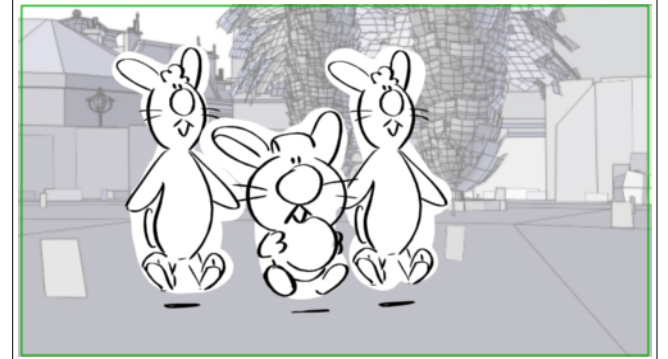
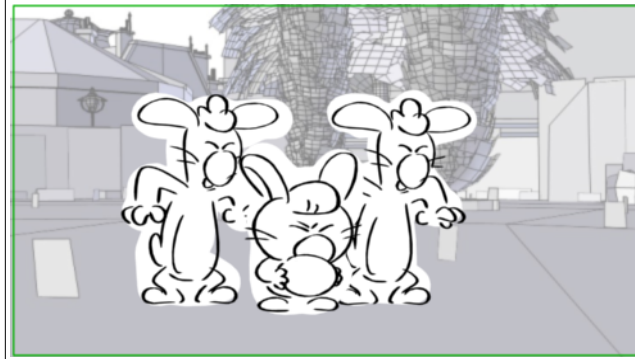
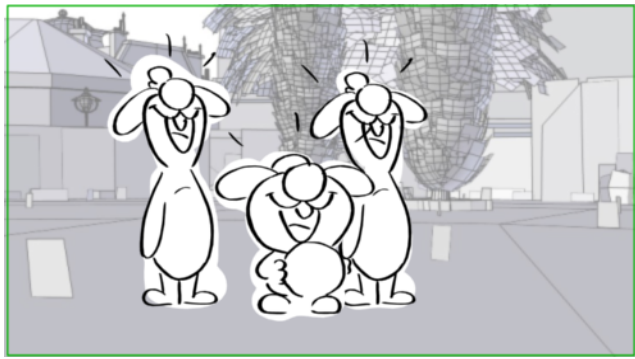

Dialogue

PICK UP
Rires!

Dialogue

47. TICCHIO MODIF
Libérez le passage!



Scene	Duration	Panel	Duration
081	05:03	9	00:13

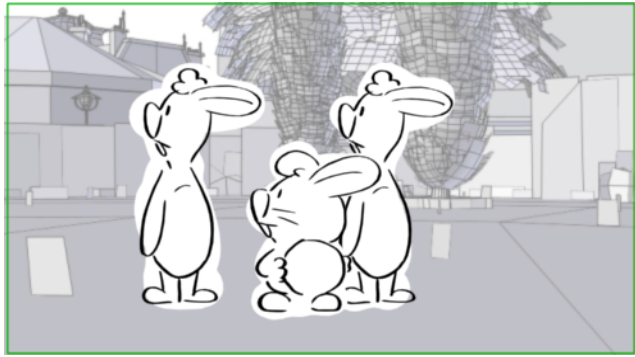

Scene	Duration	Panel	Duration
082	01:19	1	00:14

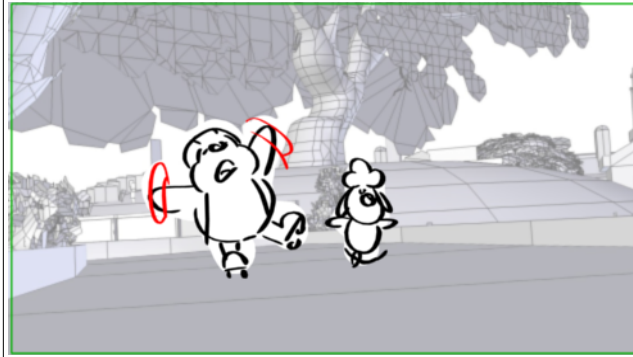

Dialogue

PICK UP BOULDI
Houlà!

Scene	Duration	Panel	Duration
082	01:19	2	00:11



Dialogue

PICK UP BOULDI
Houlà!

Scene	Duration	Panel	Duration
082	01:19	3	00:19



Dialogue
 PICK UP BOULDI
 Hou!

Scene	Duration	Panel	Duration
083	01:14	1	00:10

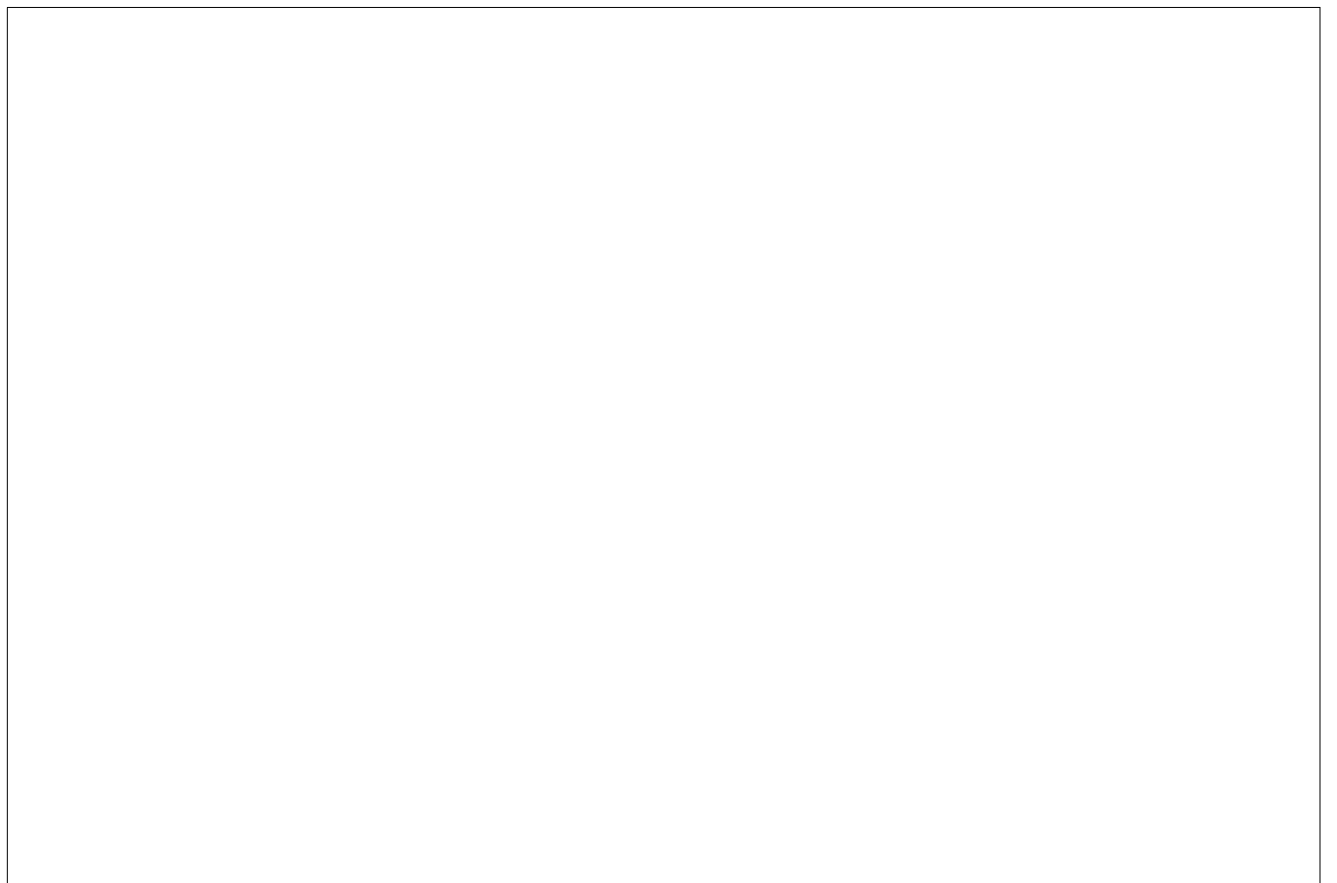
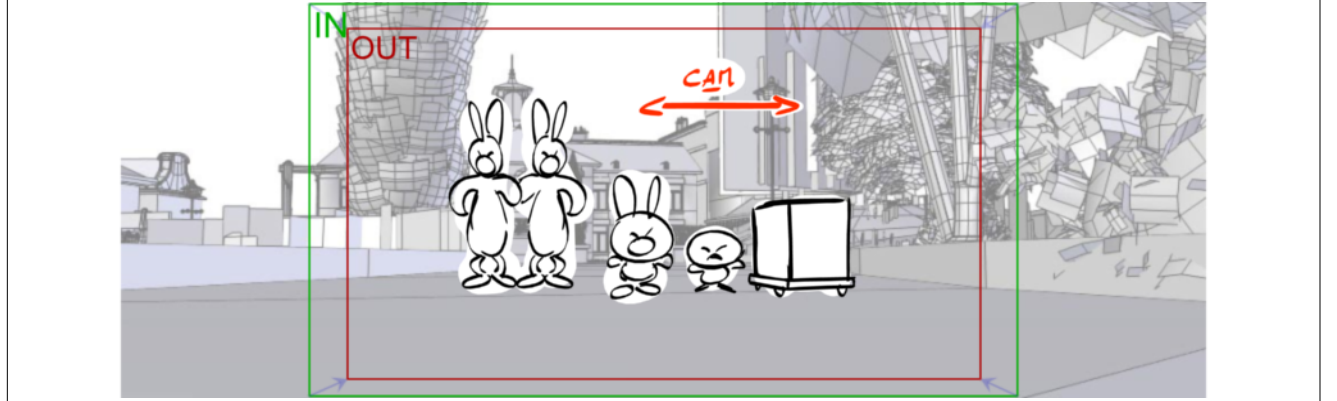



Scene	Duration	Panel	Duration
083	01:14	2	00:09

NO PANEL

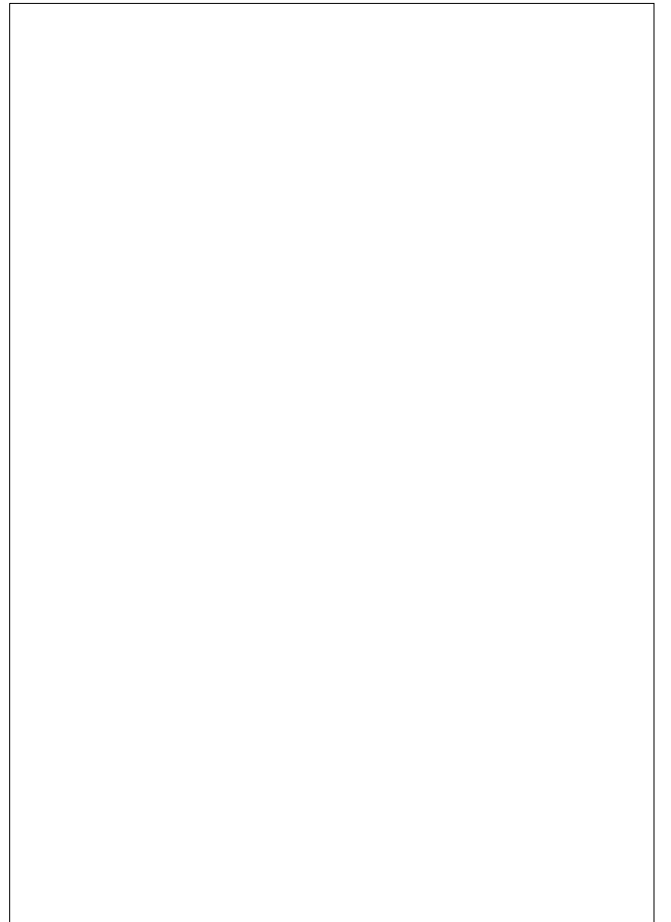
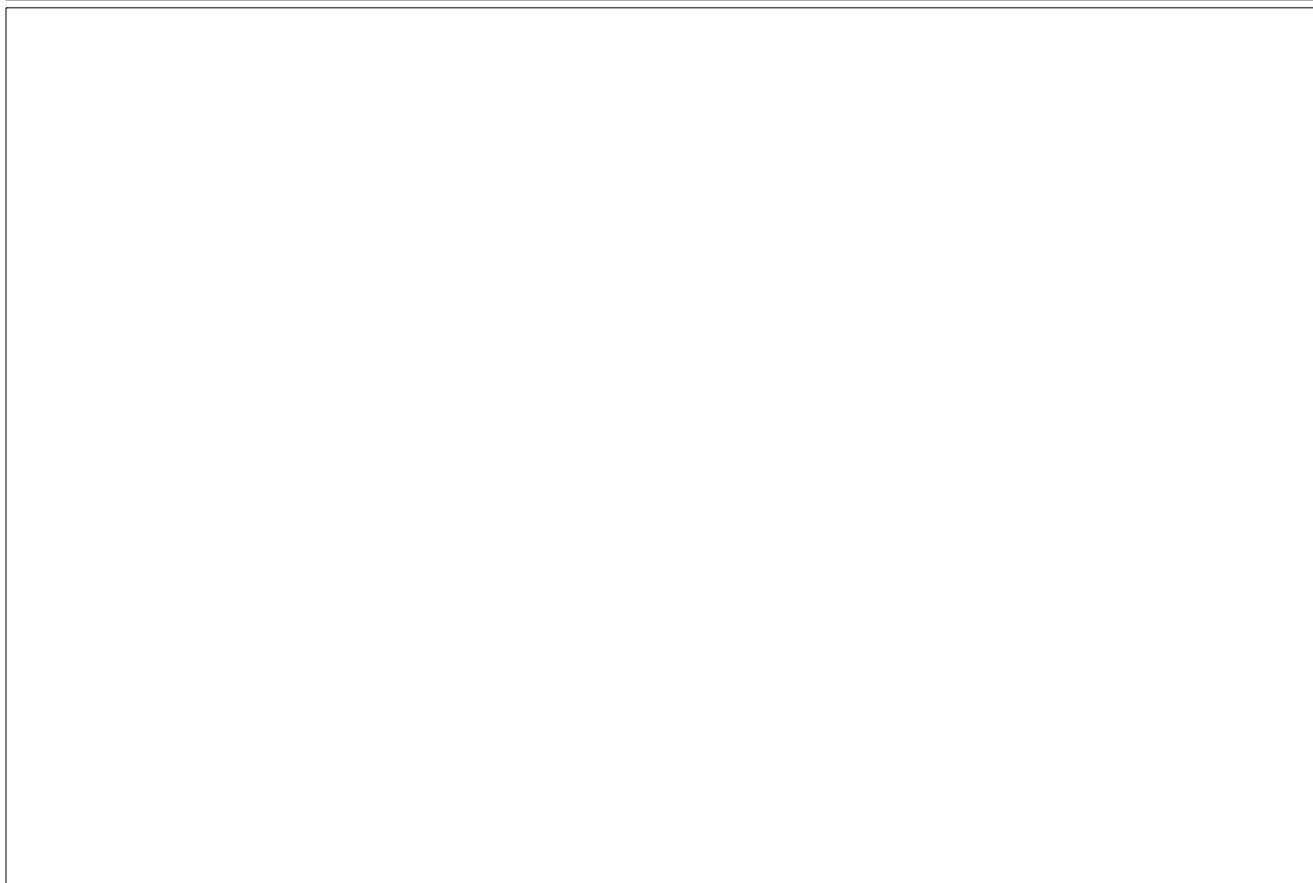
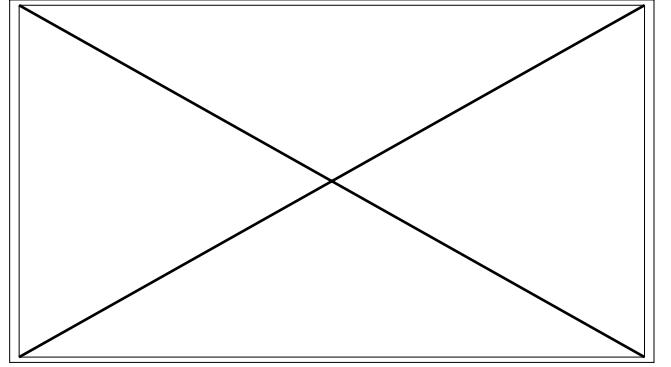
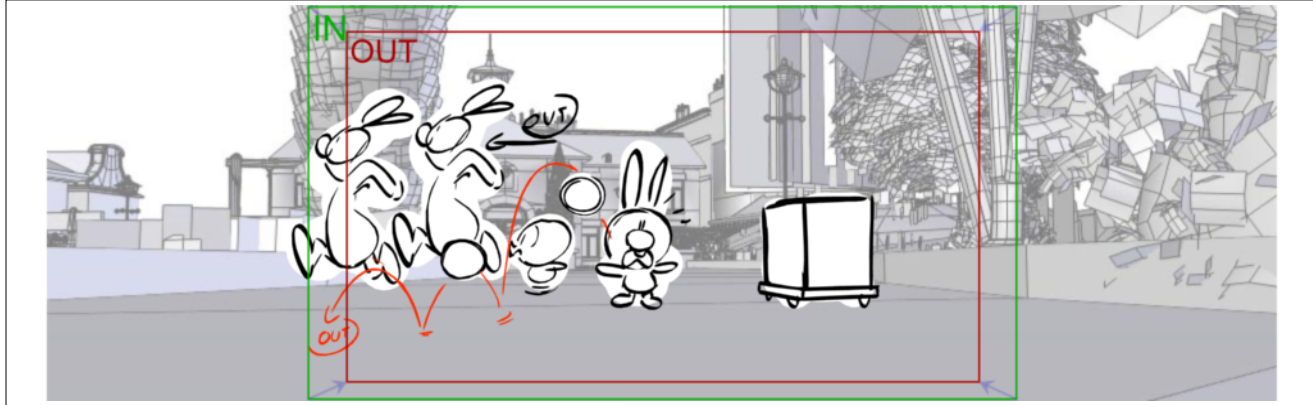



Scene	Duration	Panel	Duration
083	01:14	3	00:09

NO PANEL

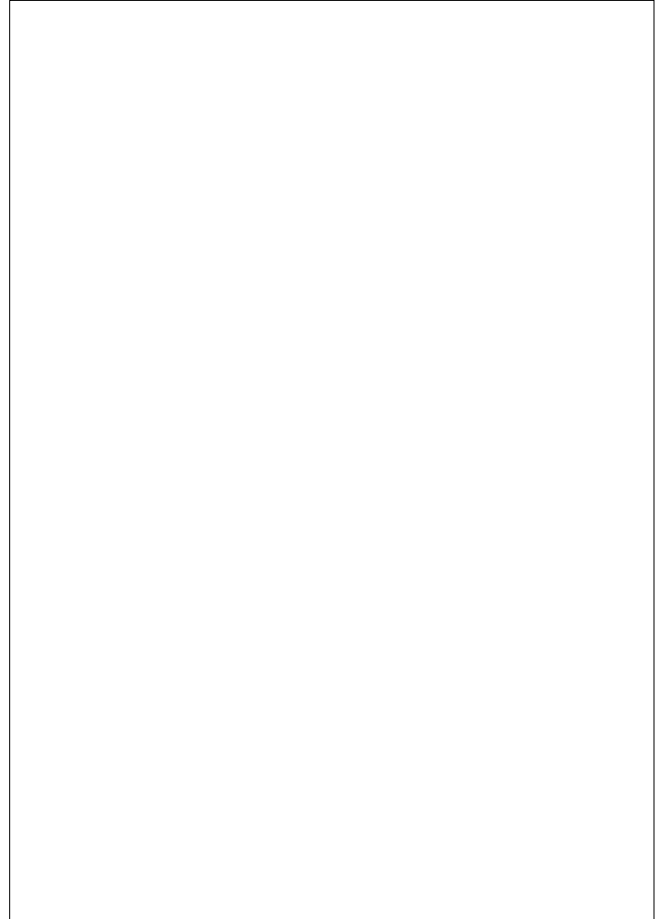
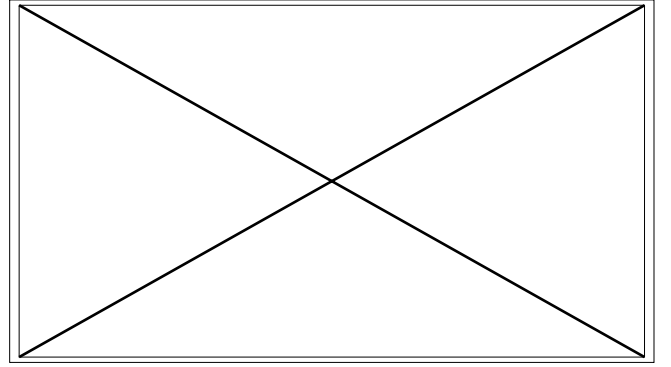
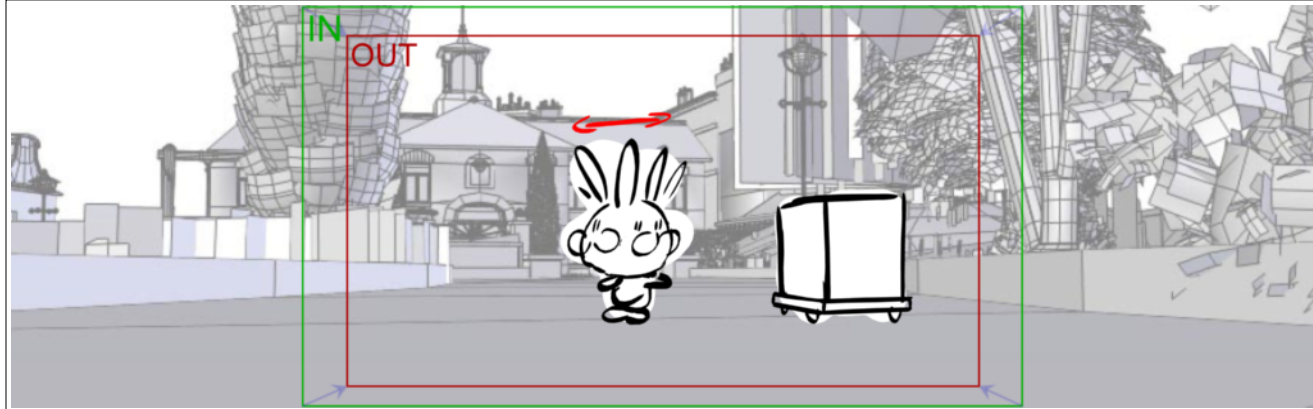

Scene	Duration	Panel	Duration
083	01:14	4	00:11

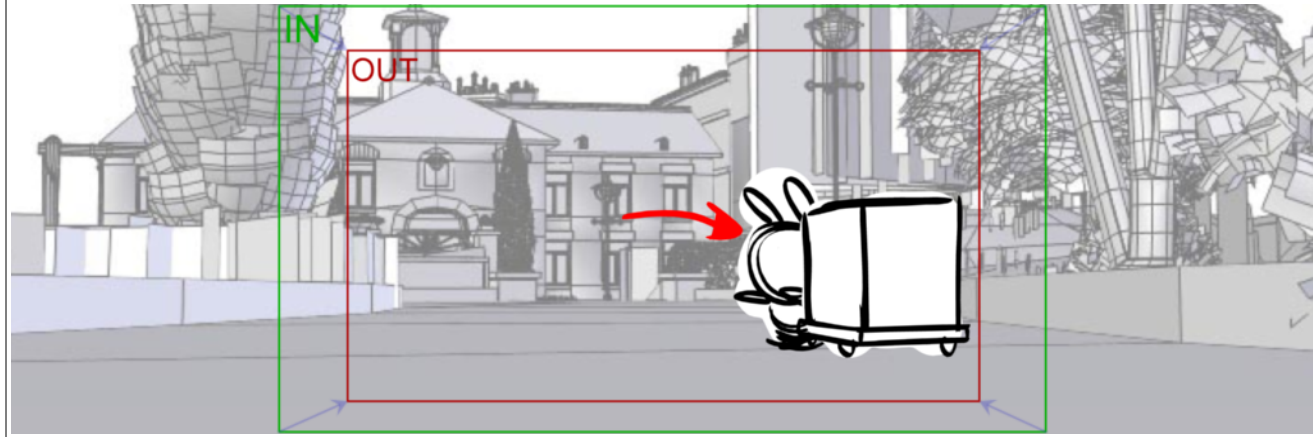

Action Notes

Pot se cache derrière le carton

Scene	Duration	Panel	Duration
084	01:21	1	00:07

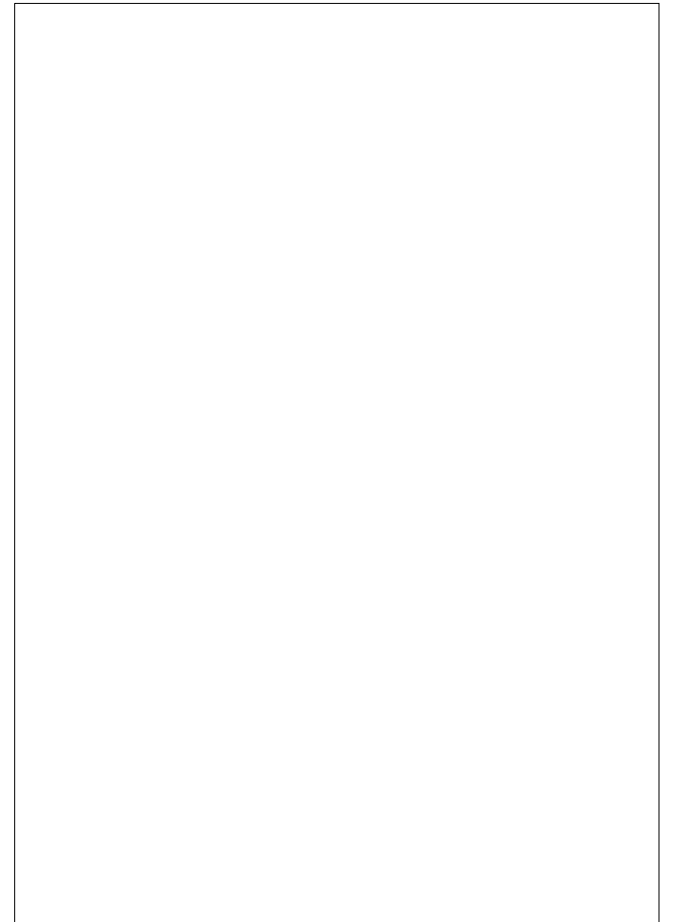
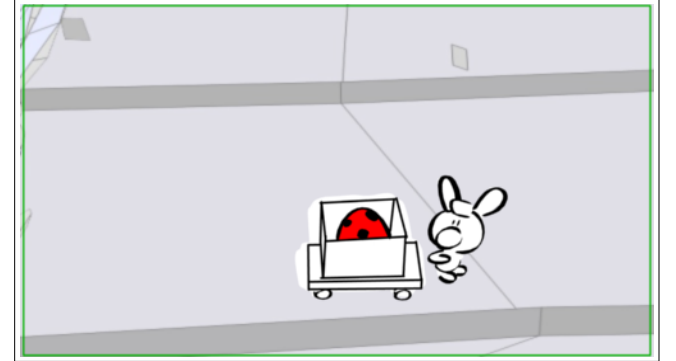

Scene	Duration	Panel	Duration
084	01:21	2	00:14

Scene	Duration	Panel	Duration
084	01:21	3	01:00

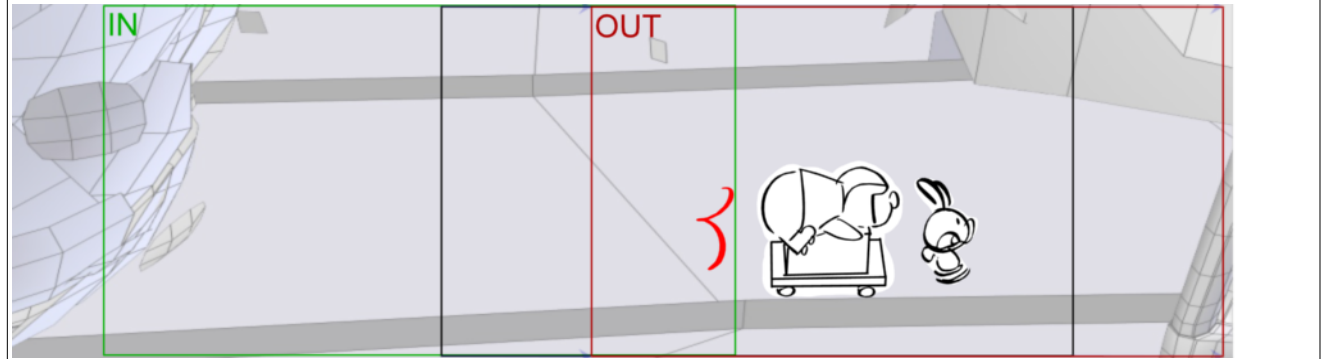
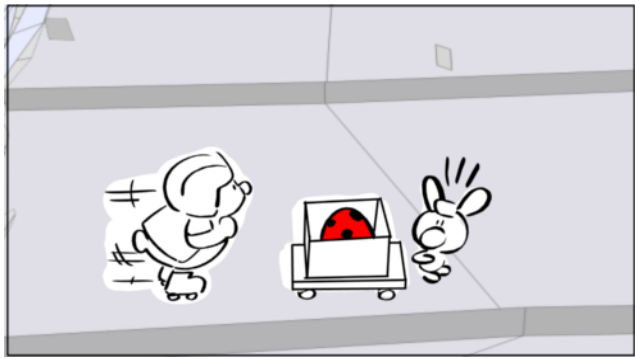



Scene	Duration	Panel	Duration
085	02:02	1	00:11

Scene	Duration	Panel	Duration
085	02:02	2	00:18

Scene	Duration	Panel	Duration
085	02:02	3	00:23

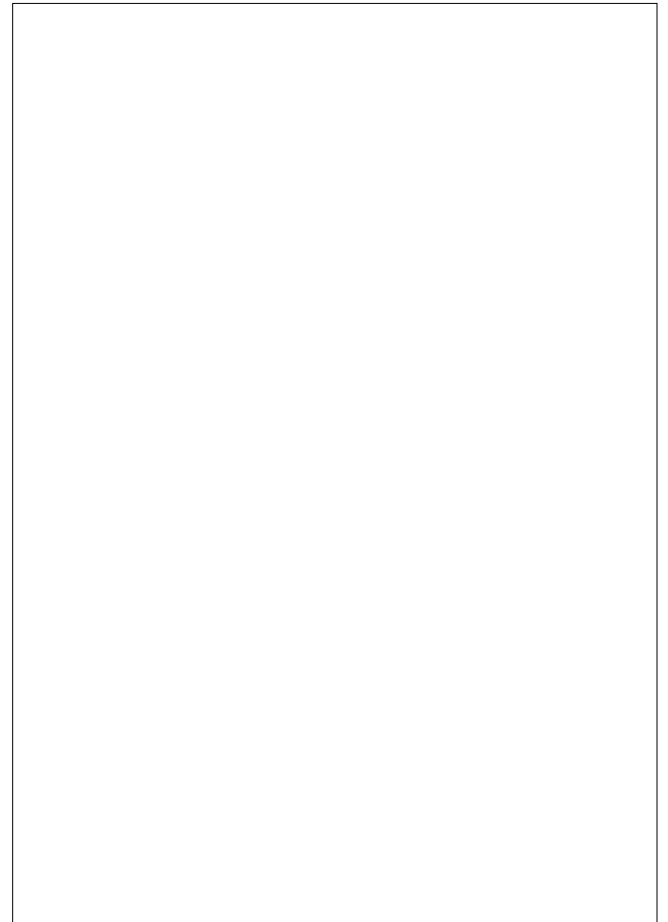
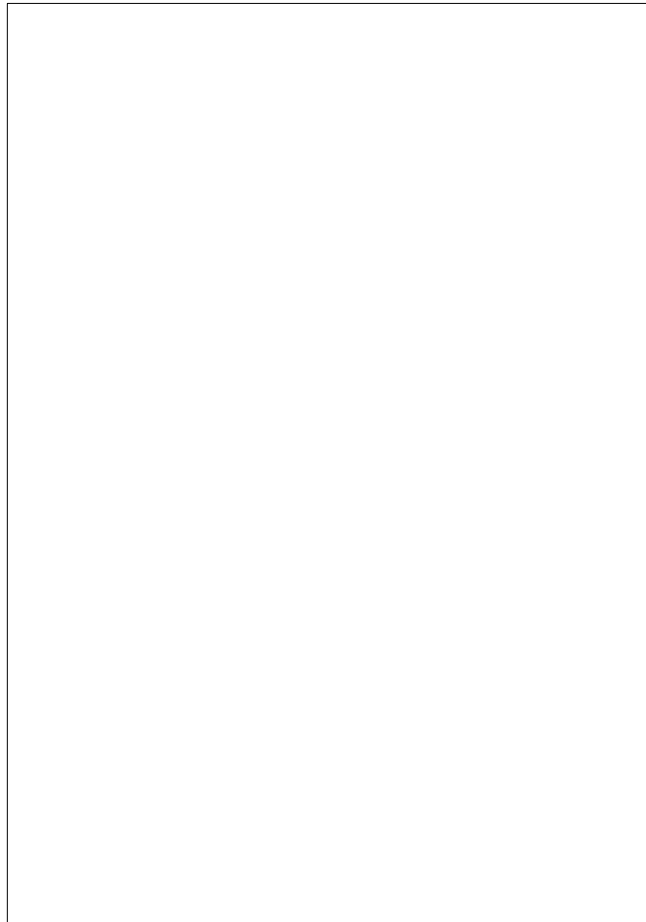
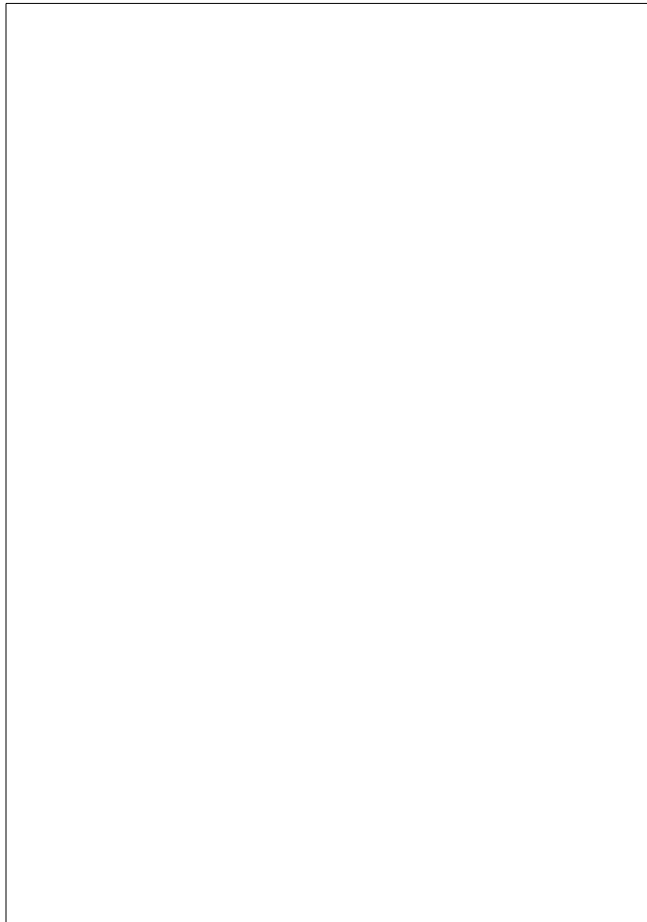

Scene	Duration	Panel	Duration
086	02:01	1	00:12

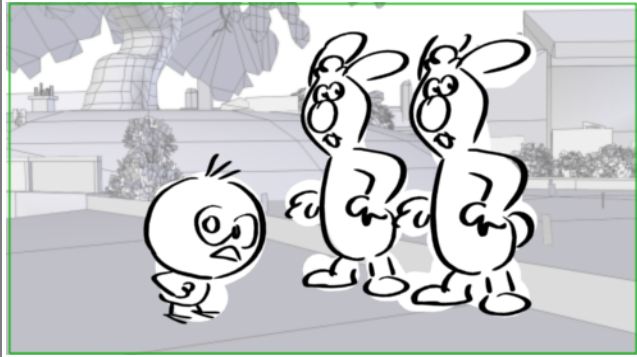

Dialogue
 50. CALIMERO (le souffle coupé)
 Ma coquille !

Scene	Duration	Panel	Duration
086	02:01	2	00:14

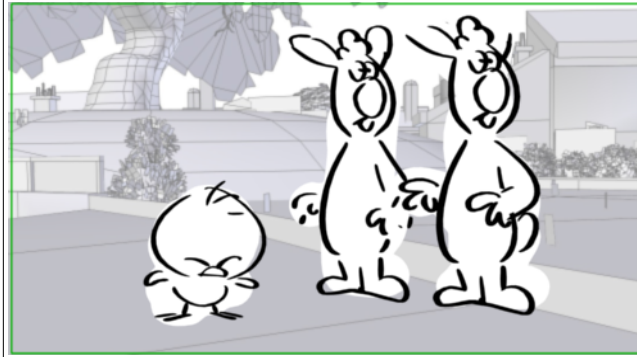

Dialogue
 50. CALIMERO (le souffle coupé)
 Ma coquille !

Scene	Duration	Panel	Duration
086	02:01	3	01:00

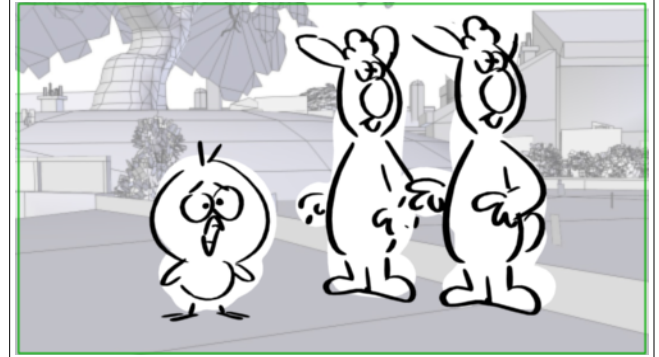

Dialogue
 50. CALIMERO (le souffle coupé)
 Ma coquille !

Scene	Duration	Panel	Duration
087	01:00	1	01:00



Scene	Duration	Panel	Duration
088	01:05	1	00:15

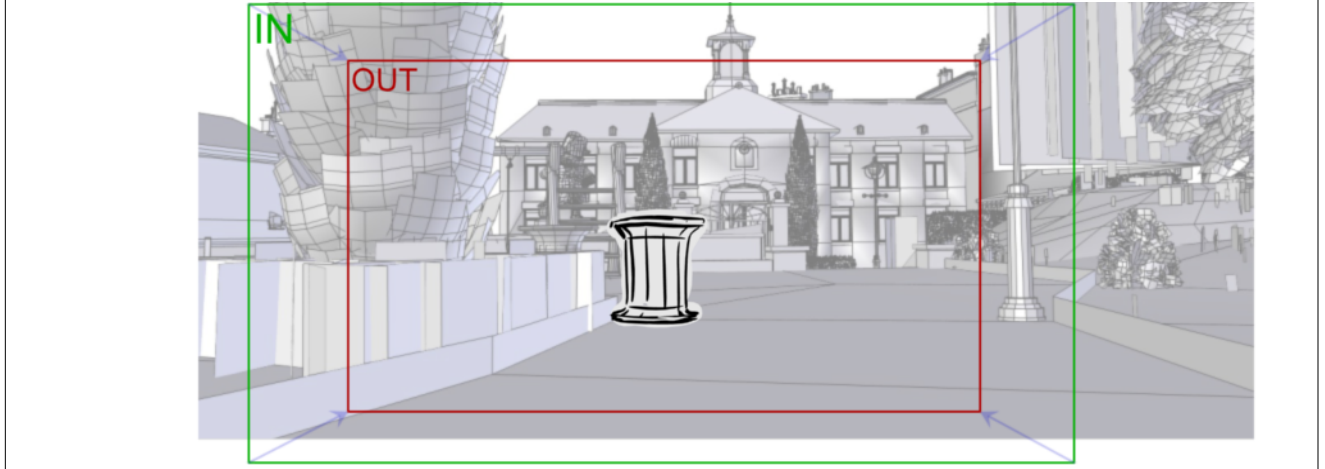



Scene	Duration	Panel	Duration
088	01:05	2	00:15

Scene	Duration	Panel	Duration
089	02:07	1	00:10

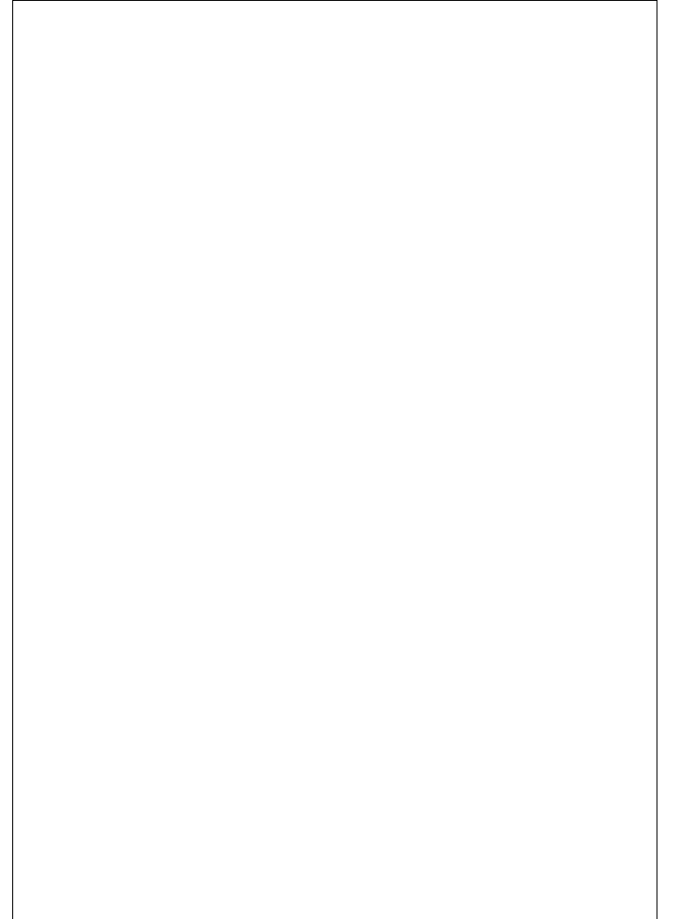
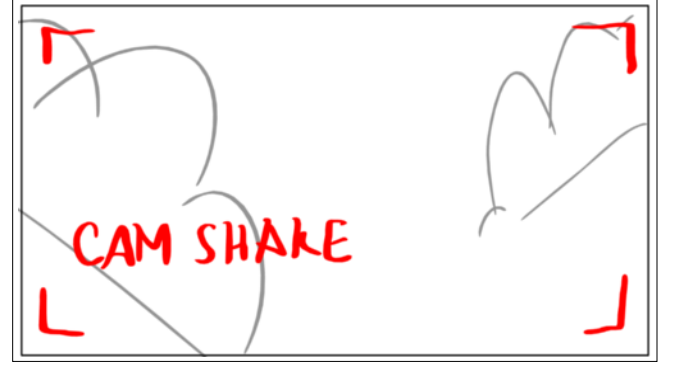
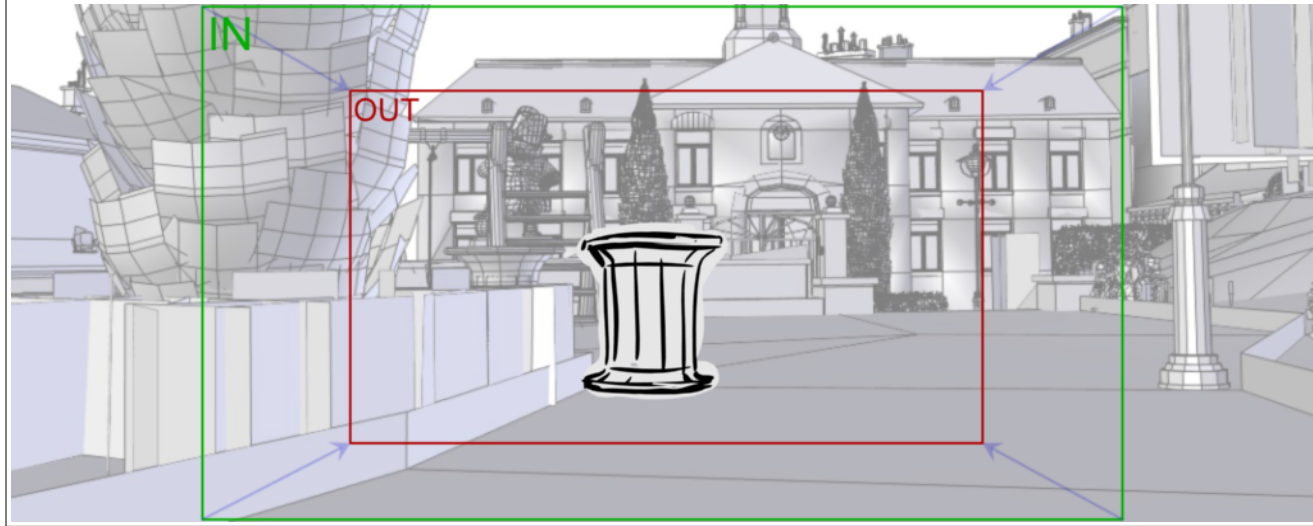



Scene	Duration	Panel	Duration
089	02:07	2	00:07

Scene	Duration	Panel	Duration
089	02:07	3	00:07

Scene	Duration	Panel	Duration
089	02:07	4	00:12

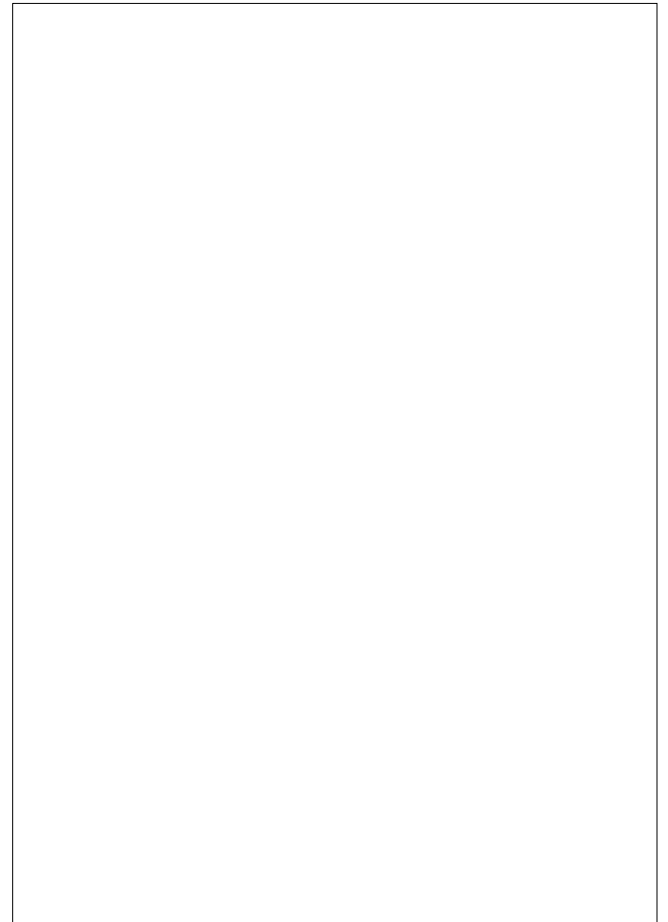
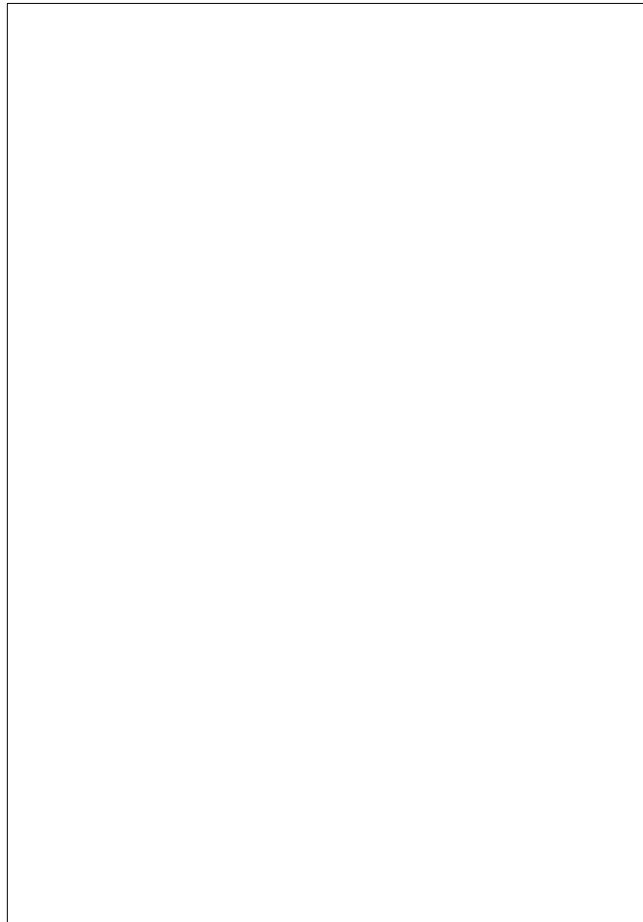
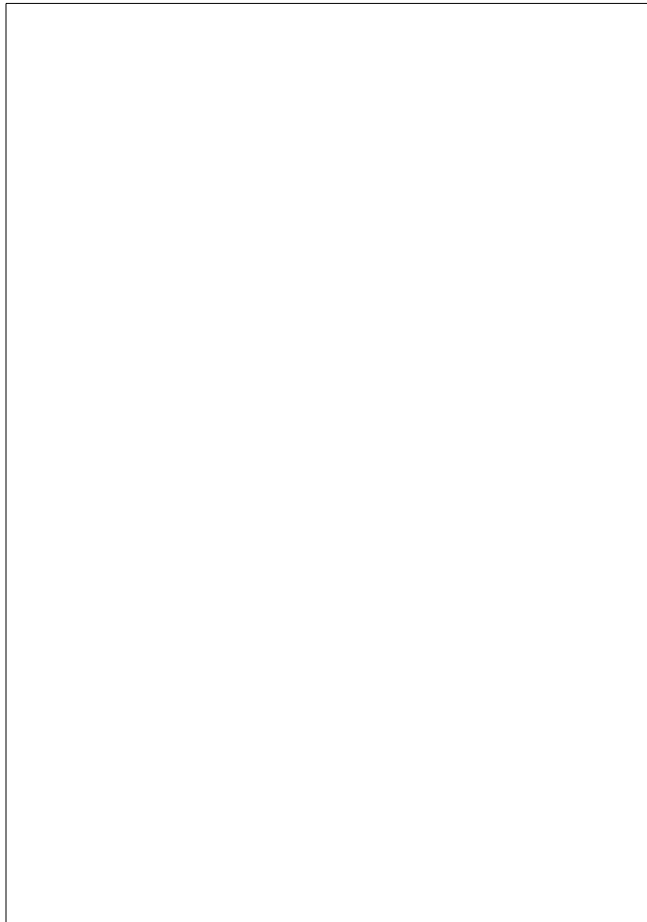
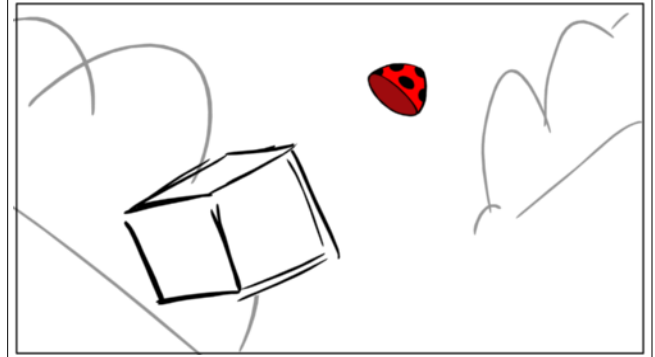
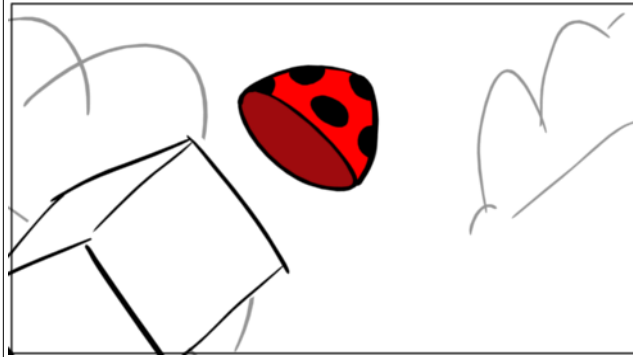
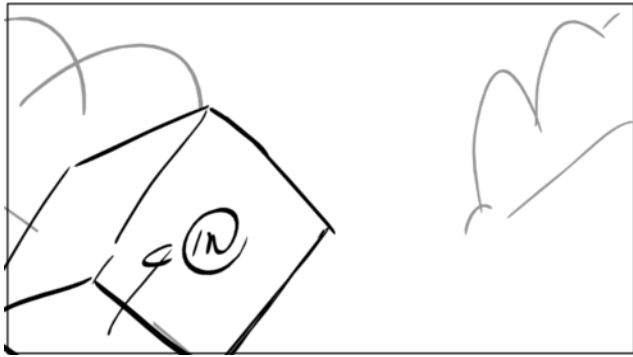



Scene	Duration	Panel	Duration
089	02:07	5	00:10

Scene	Duration	Panel	Duration
089	02:07	6	00:11

Scene	Duration	Panel	Duration
090	10:14	1	01:03

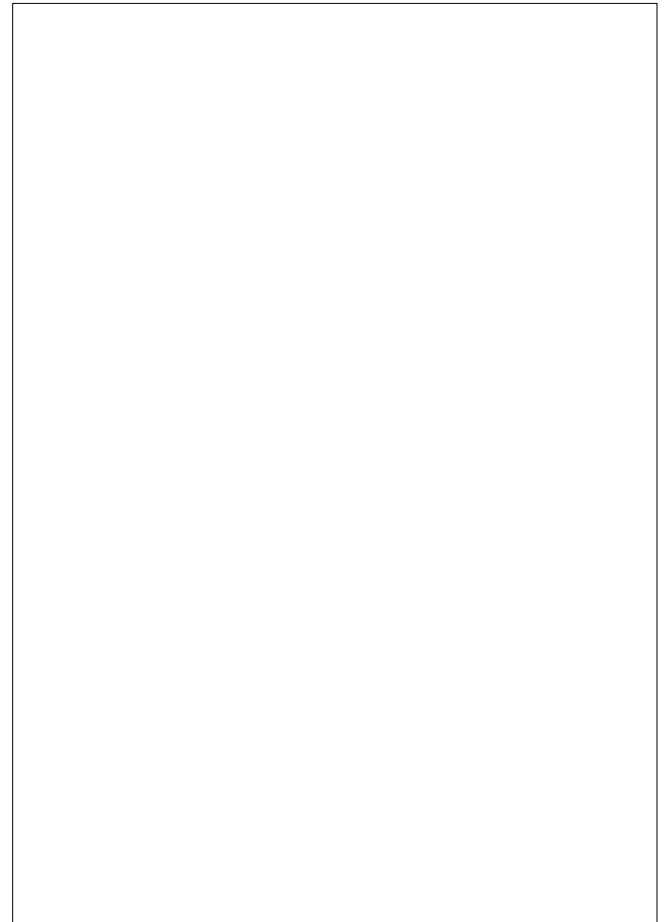
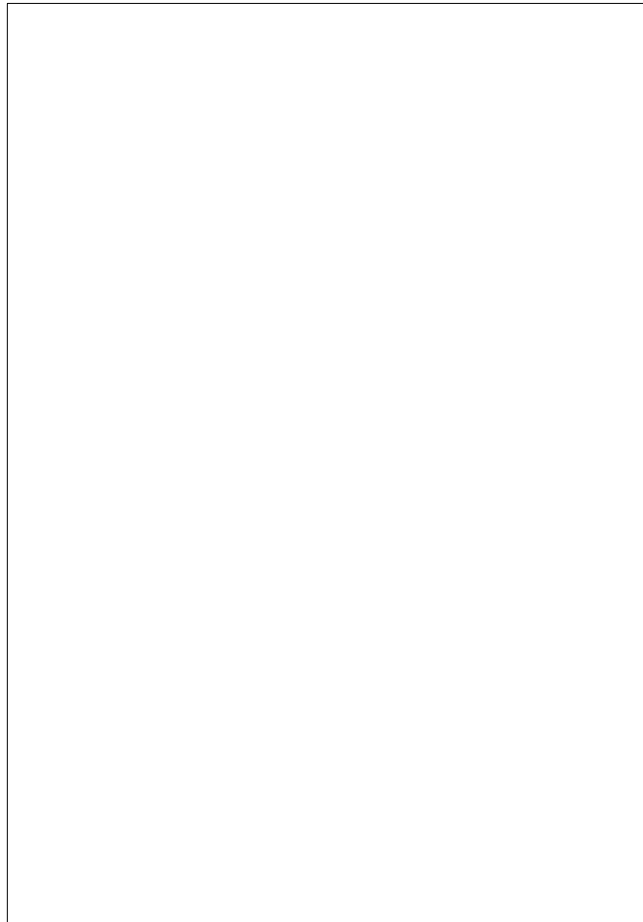
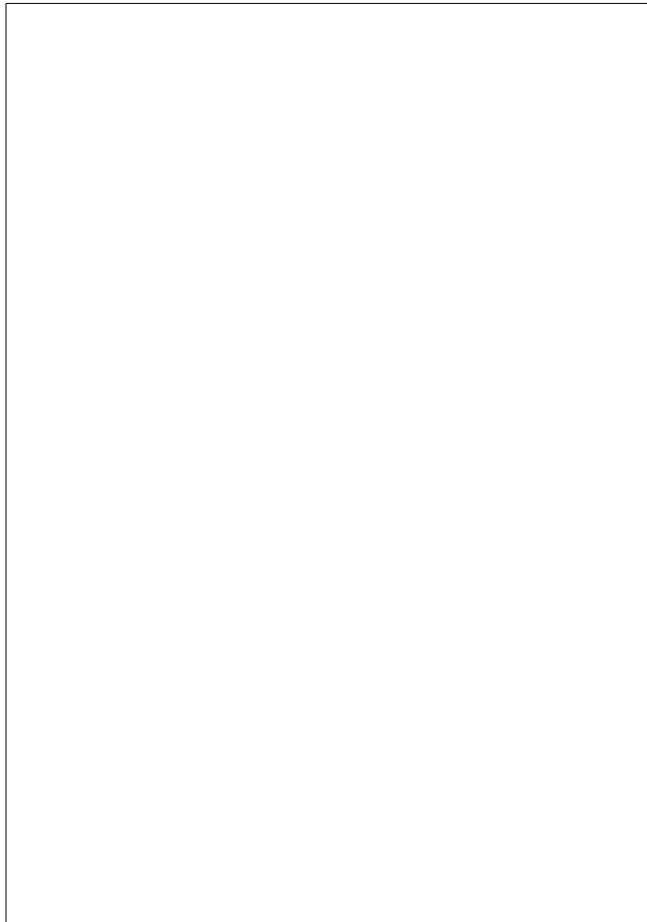
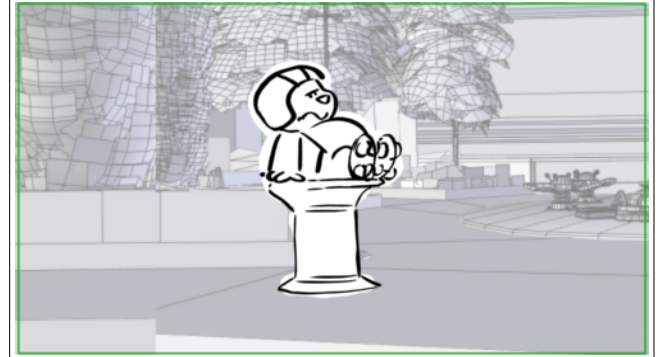
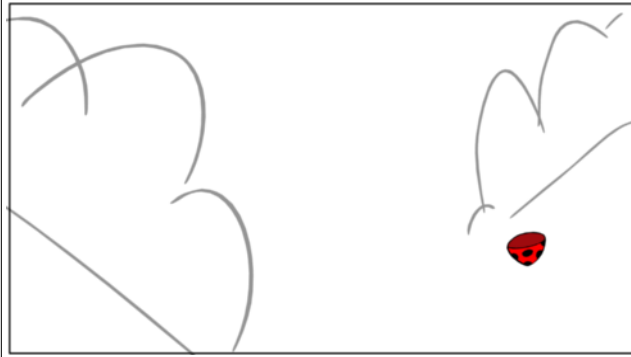
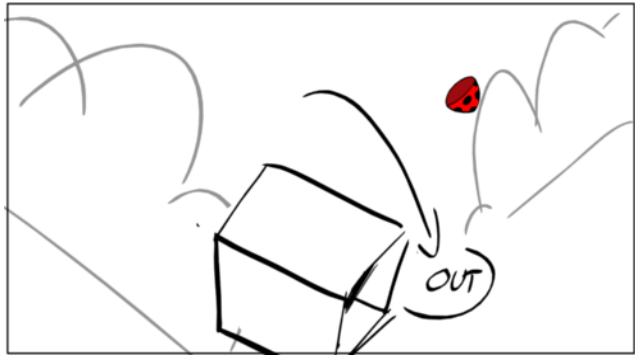

Scene	Duration	Panel	Duration
090	10:14	2	00:16

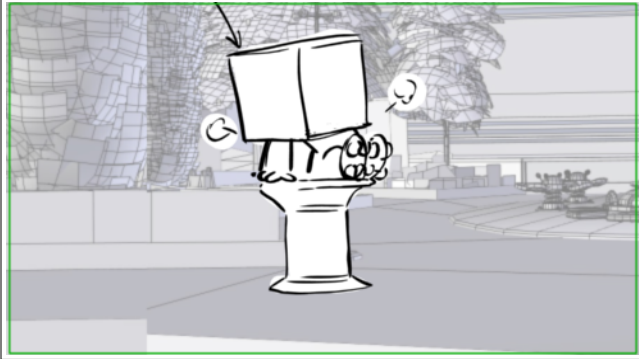

Scene	Duration	Panel	Duration
090	10:14	3	01:05

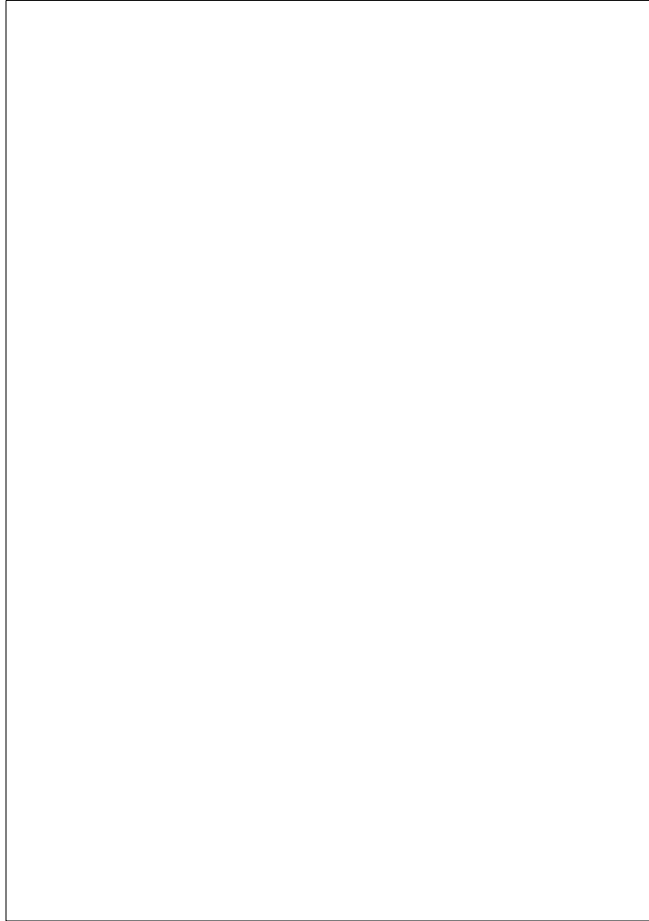
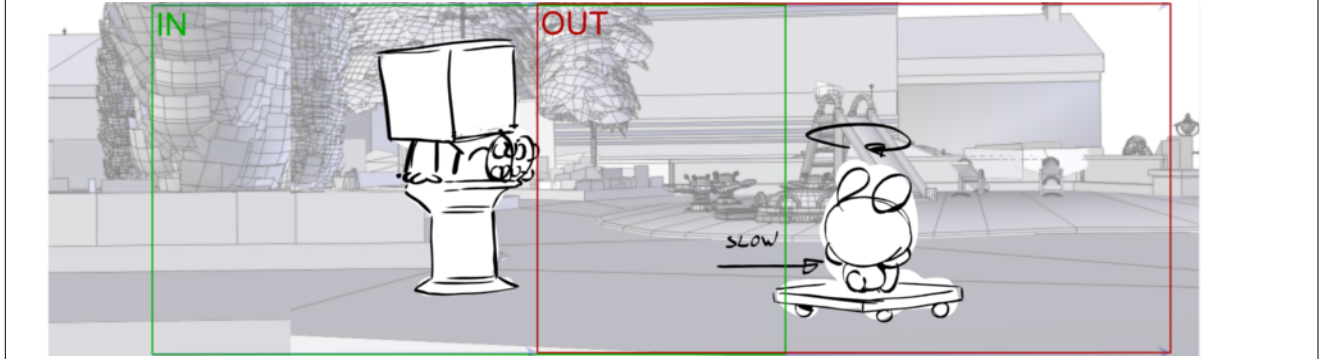



Scene	Duration	Panel	Duration
090	10:14	4	00:14

Scene	Duration	Panel	Duration
090	10:14	5	00:20

Scene	Duration	Panel	Duration
090	10:14	6	00:16

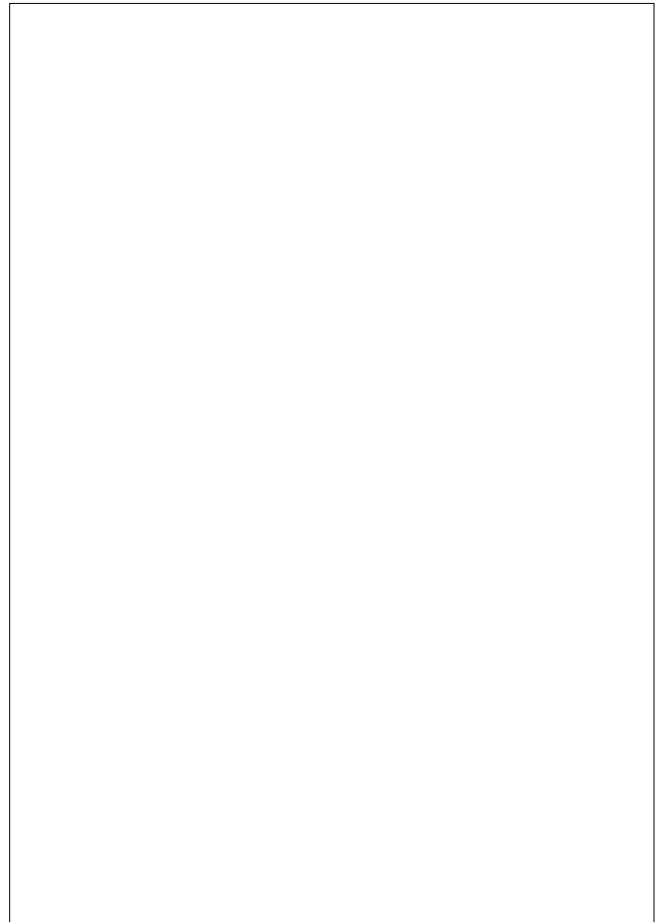
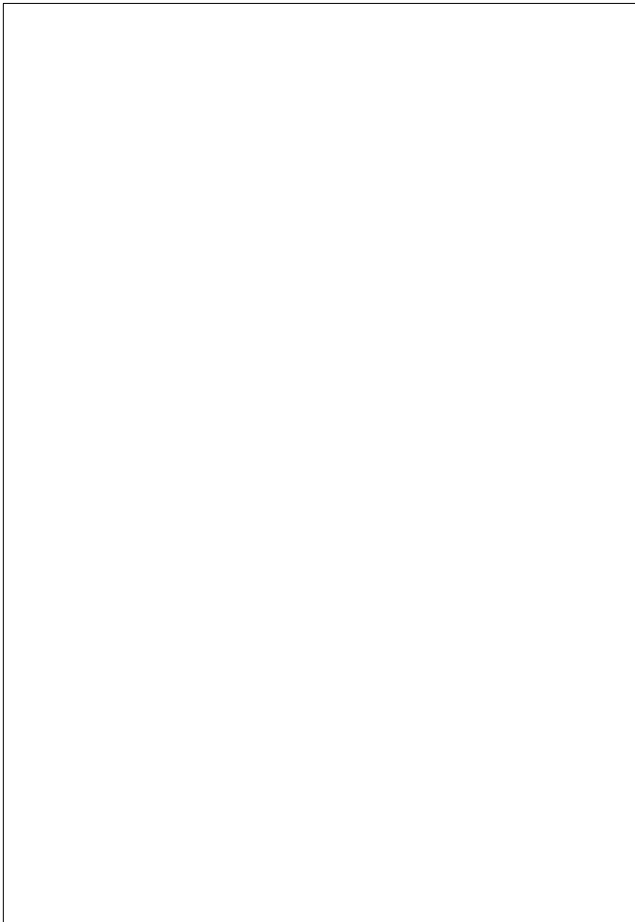
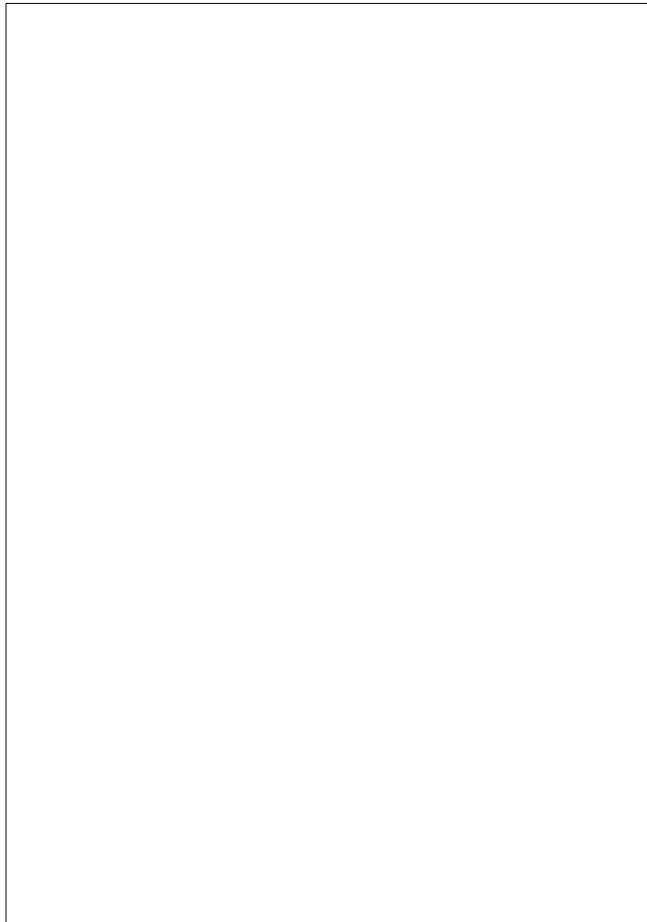
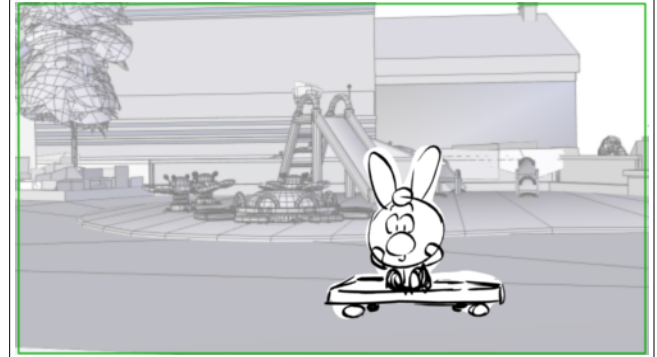
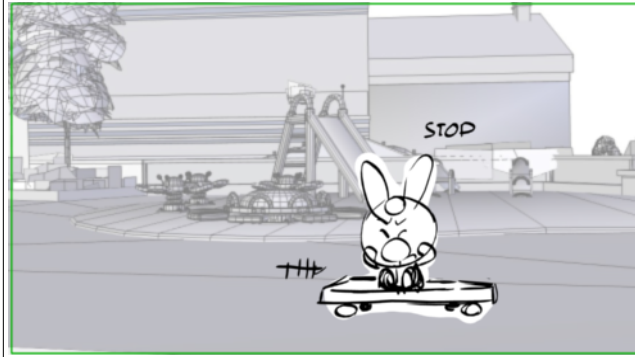
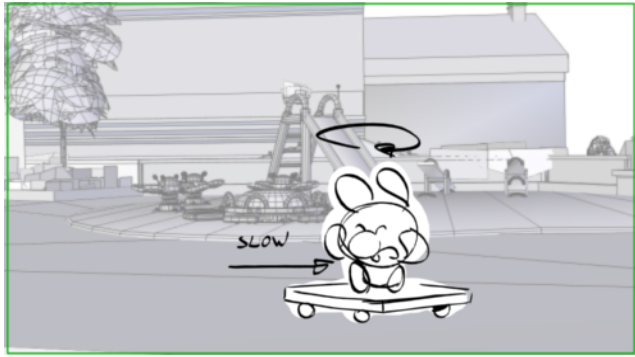



Scene	Duration	Panel	Duration
090	10:14	7	00:10

Scene	Duration	Panel	Duration
090	10:14	8	00:12

Scene	Duration	Panel	Duration
090	10:14	9	01:00

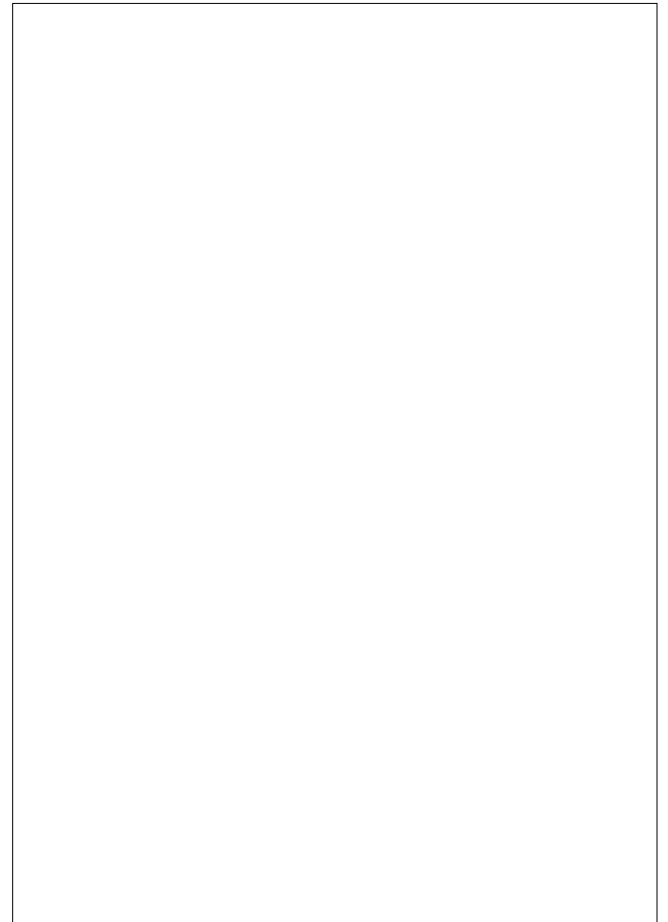
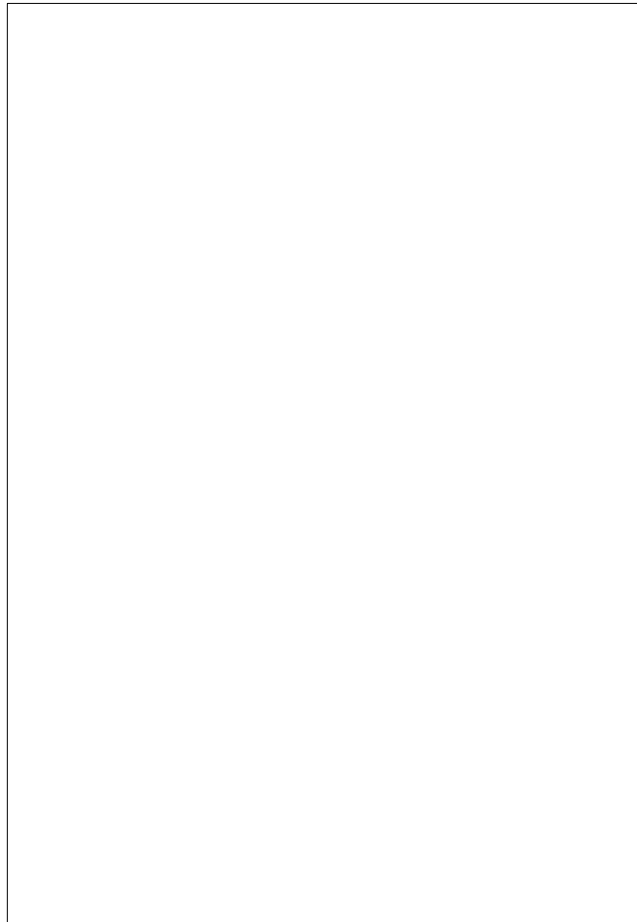
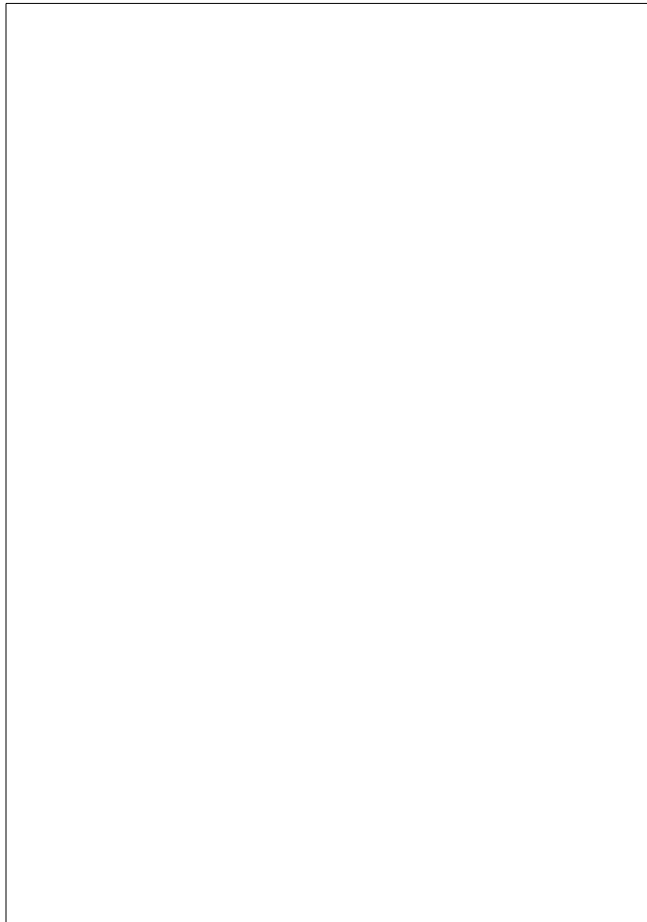
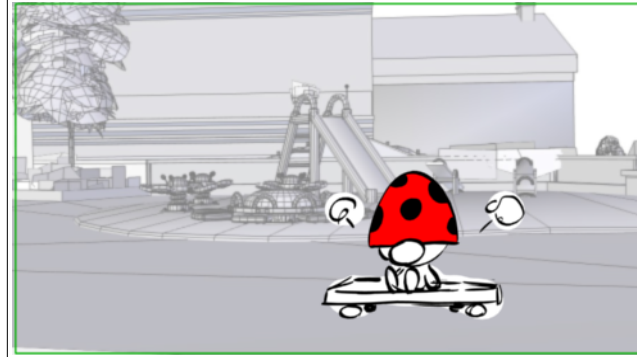
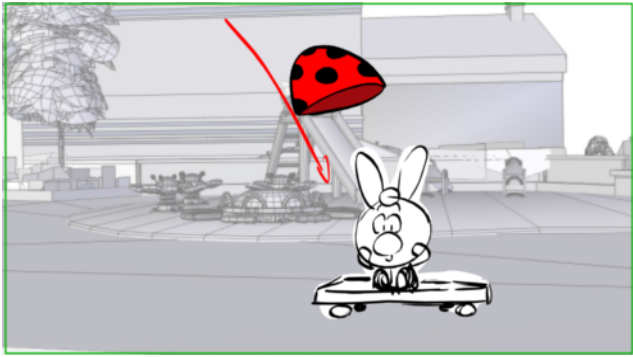

Scene	Duration	Panel	Duration
090	10:14	10	01:13

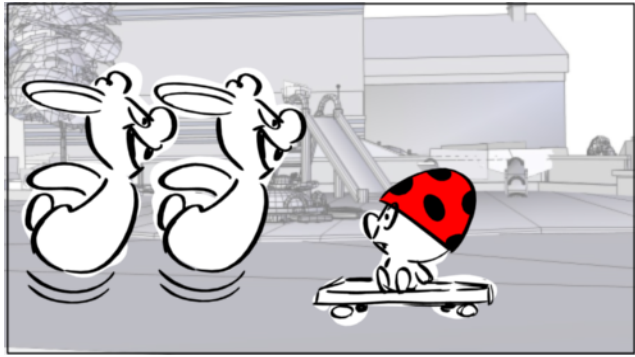

Scene	Duration	Panel	Duration
090	10:14	11	01:17

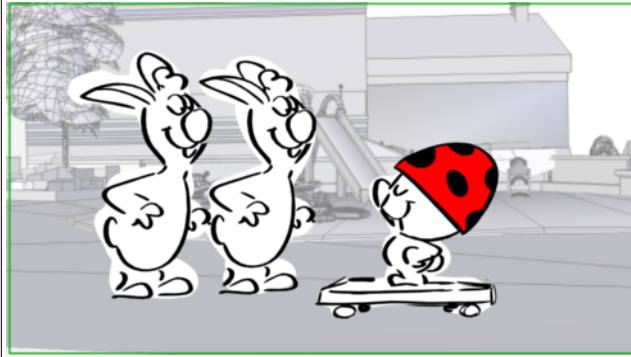

Dialogue
 53. MODIF MOT (espiègle)
 Bien joué, Pot !

Scene	Duration	Panel	Duration
090	10:14	12	00:13

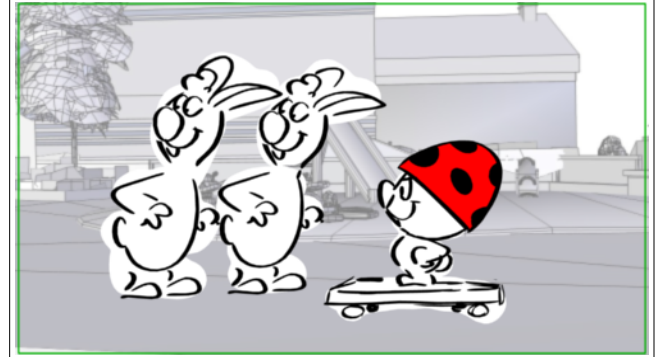

Dialogue
 PICK UP CALIMERO (en colère)
 Pot !



Scene	Duration	Panel	Duration
091	01:16	1	00:08

Scene	Duration	Panel	Duration
091	01:16	2	00:19

Scene	Duration	Panel	Duration
091	01:16	3	00:14

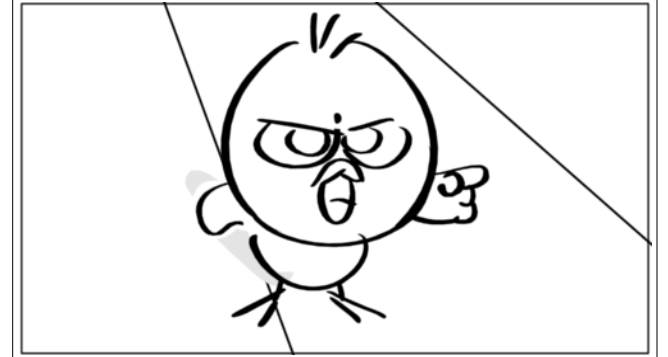
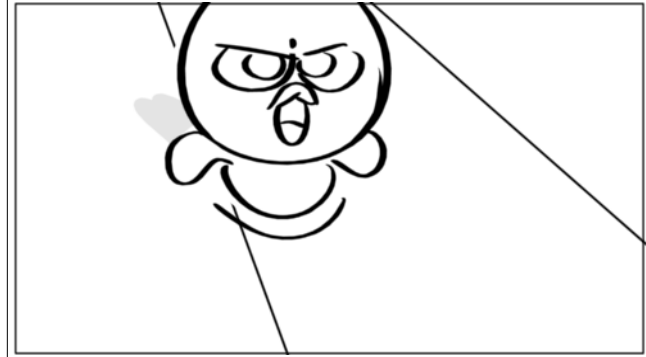
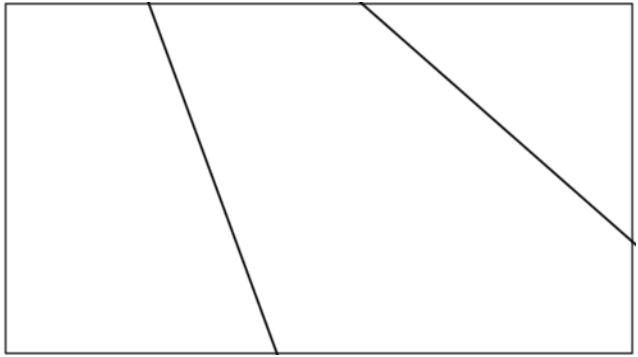

Dialogue
PICK UP CALIMERO
Rends moi ma coquille!

Dialogue
PICK UP CALIMERO
Rends moi ma coquille!

Scene	Duration	Panel	Duration
092	12:21	1	00:16



Dialogue

51. POT (faussement embêté)
 Heureusement que j'étais là ! Elle a
 failli s'écrabouiller !

Scene	Duration	Panel	Duration
092	12:21	2	00:23

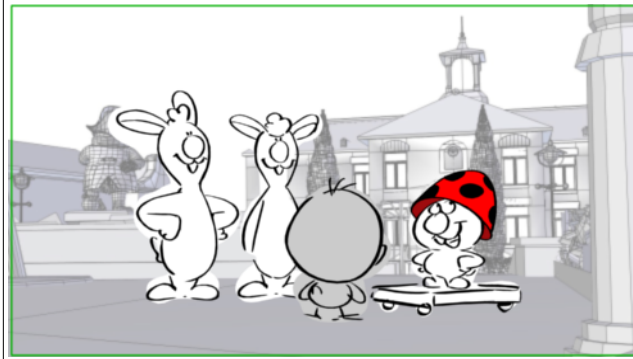

Dialogue

51. POT (faussement embêté)
 Heureusement que j'étais là ! Elle a
 failli s'écrabouiller !

Scene	Duration	Panel	Duration
092	12:21	3	00:10



Dialogue

51. POT (faussement embêté)
 Heureusement que j'étais là ! Elle a
 failli s'écrabouiller !

Scene	Duration	Panel	Duration
092	12:21	4	00:18



Dialogue

51. POT (faussement embêté)
 Heureusement que j'étais là ! Elle a
 failli s'écrabouiller !

Scene	Duration	Panel	Duration
092	12:21	5	02:14



Dialogue

51. POT (faussement embêté)
 (rigolard) Dis, tu me prêtes ta
 coquille, Caliméro ? J'ai carnaval !

Scene	Duration	Panel	Duration
092	12:21	6	01:01



Dialogue

51. POT (faussement embêté)
 (rigolard) Dis, tu me prêtes ta
 coquille, Caliméro ? J'ai carnaval !

Scene	Duration	Panel	Duration
092	12:21	7	01:00



Dialogue

PICK UP RIRES

Scene	Duration	Panel	Duration
092	12:21	8	02:00

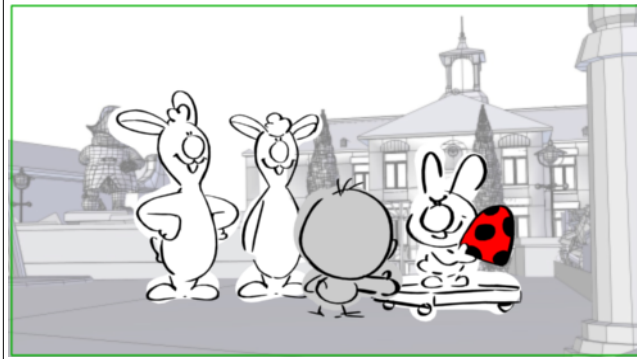

Dialogue

52. CALIMERO (sûr de lui, en attaque)
Pas question ! Rends la moi !

Scene	Duration	Panel	Duration
092	12:21	9	01:00



Dialogue

PICK UP
Ha! Tu peux courir!

Scene	Duration	Panel	Duration
092	12:21	10	00:16



Dialogue

52. CALIMERO (sûr de lui, en attaque)
Pas question ! Rends la moi !

Scene	Duration	Panel	Duration
092	12:21	11	01:09

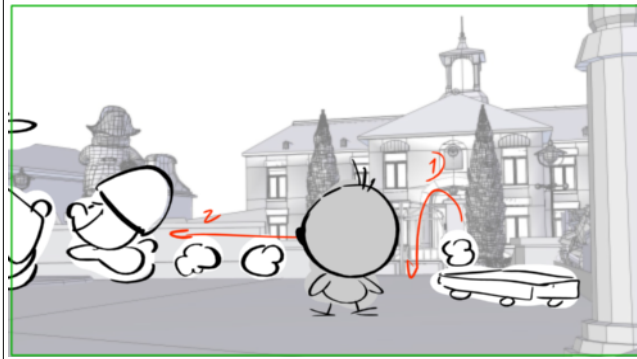

Scene	Duration	Panel	Duration
092	12:21	12	00:14

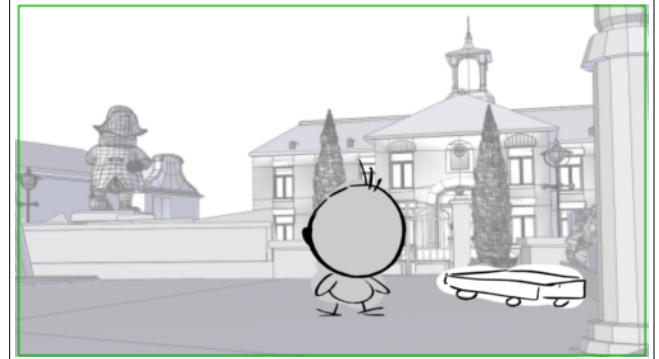

Scene	Duration	Panel	Duration
093	07:00	1	01:00

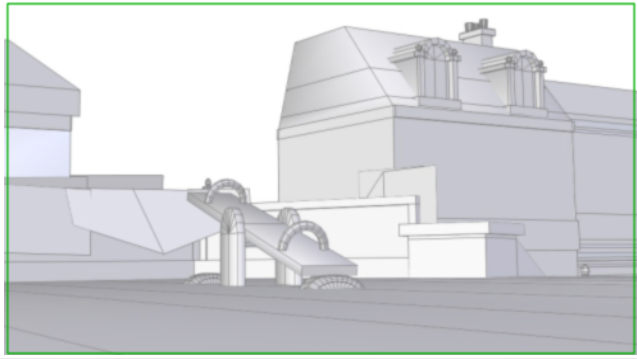

Scene	Duration	Panel	Duration
093	07:00	2	01:00

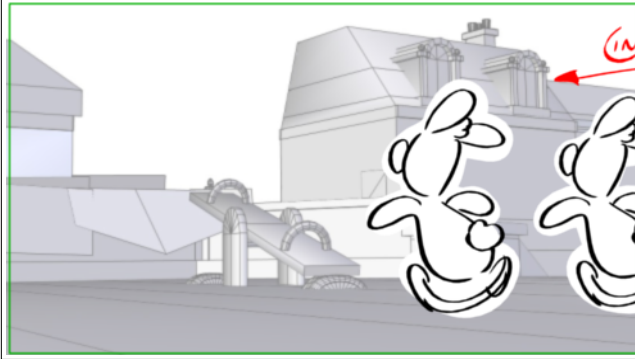

Scene	Duration	Panel	Duration
093	07:00	3	01:00

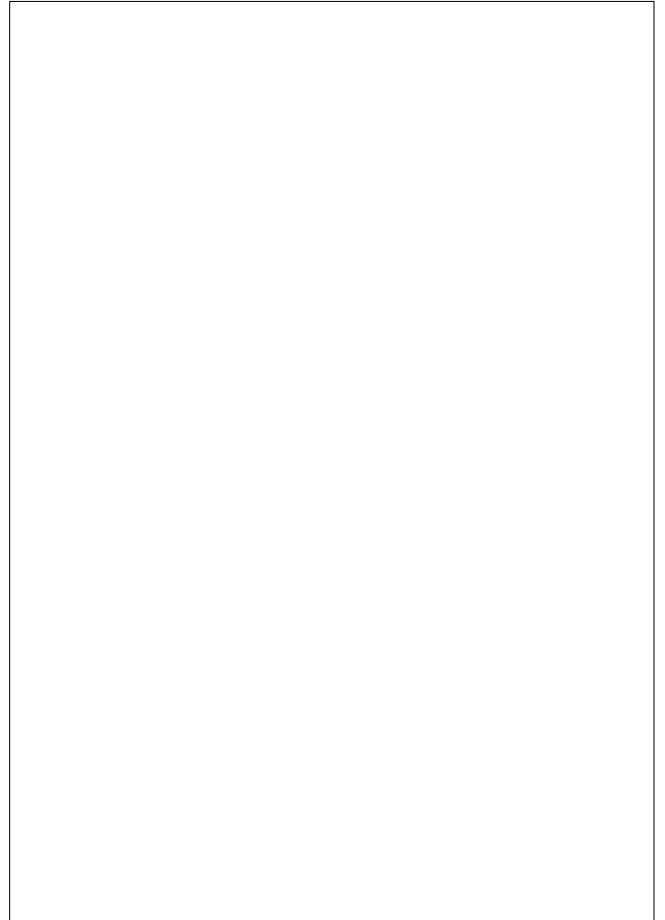
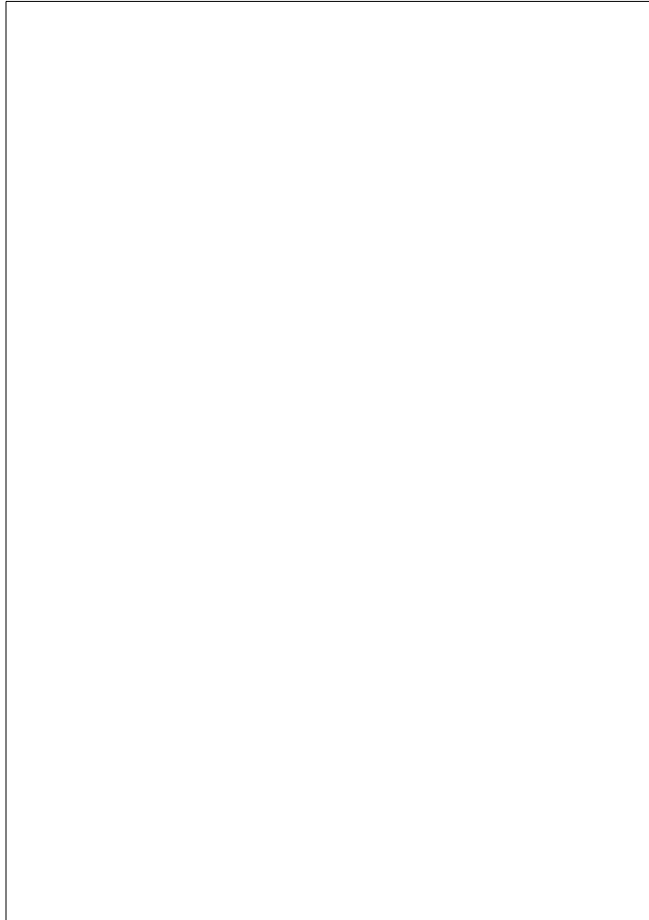
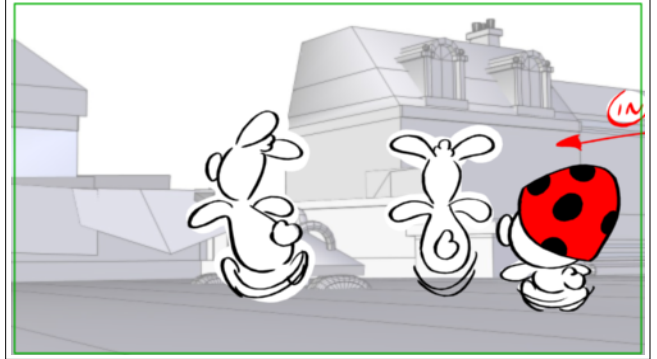



Scene	Duration	Panel	Duration
093	07:00	4	01:00

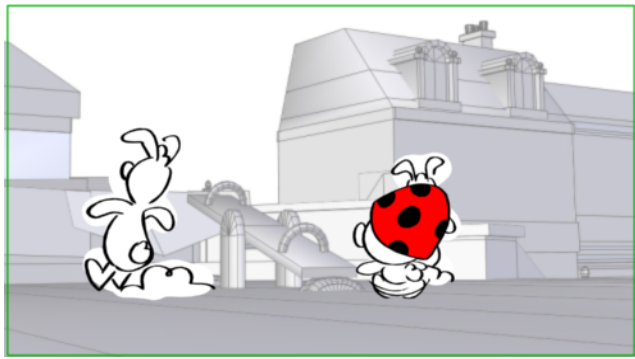

Scene	Duration	Panel	Duration
093	07:00	5	01:00

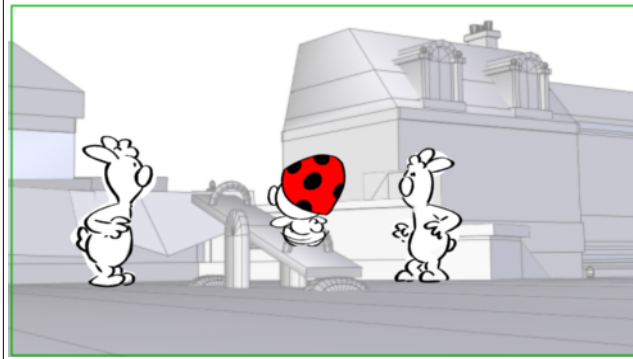

Scene	Duration	Panel	Duration
093	07:00	6	01:00

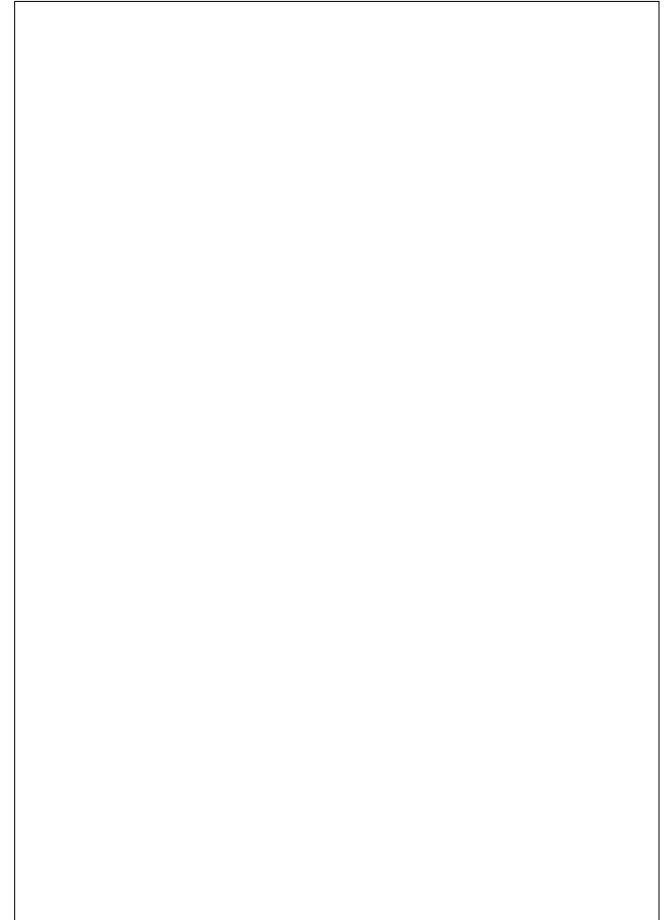
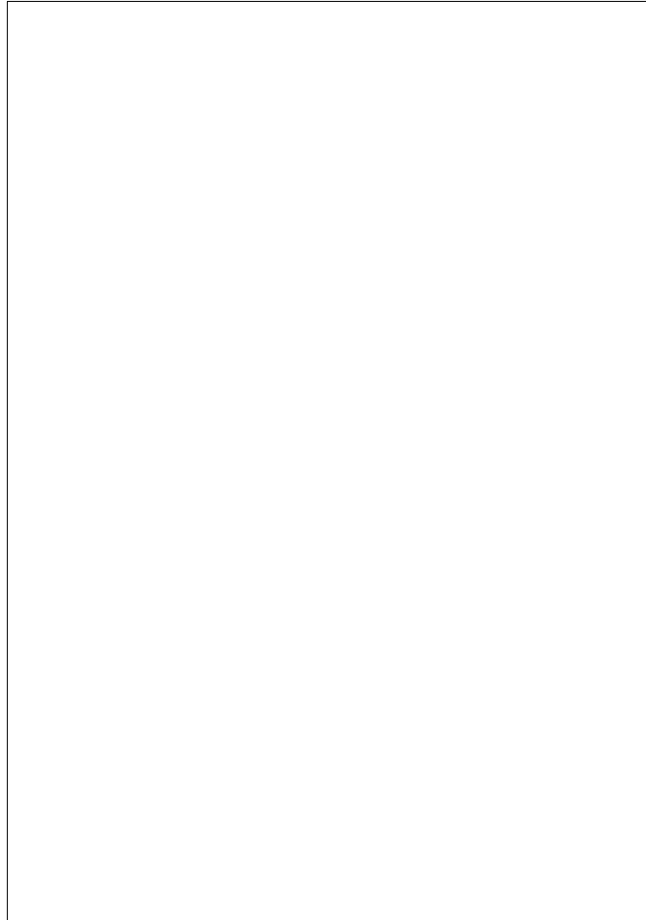
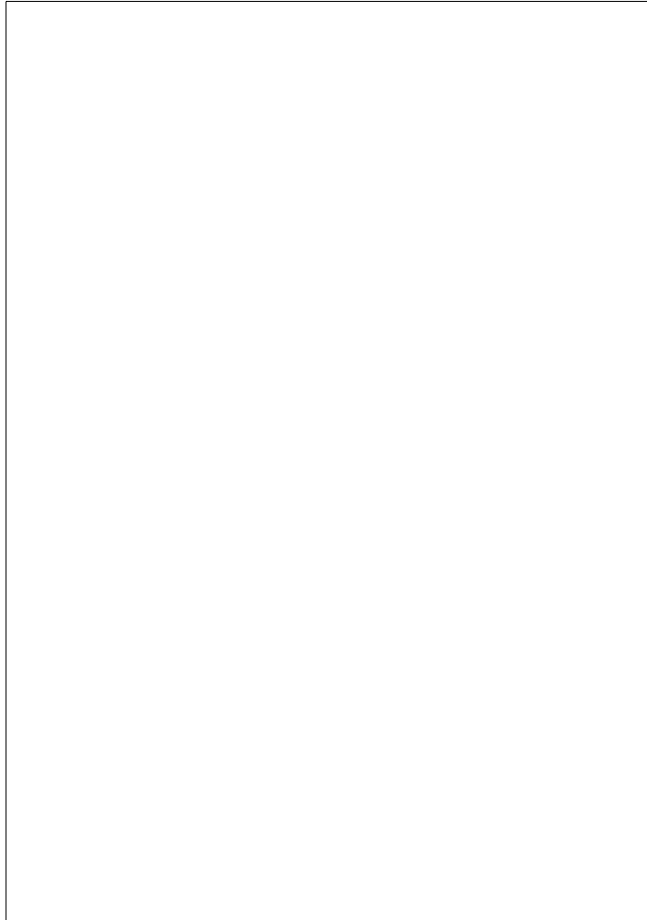
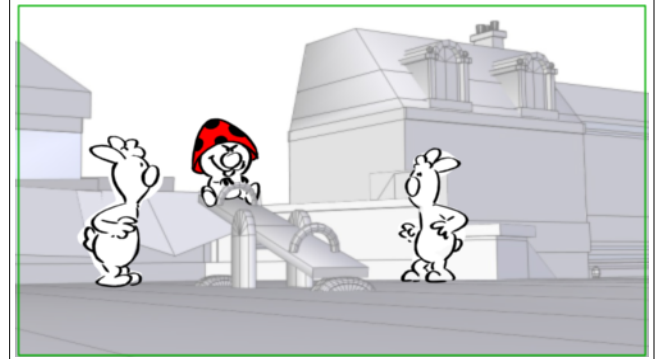

Scene	Duration	Panel	Duration
093	07:00	7	01:00

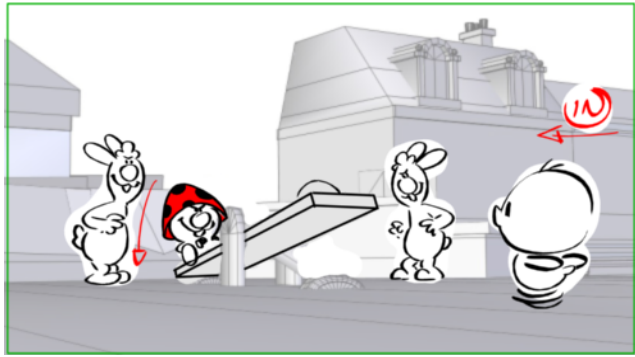

Scene	Duration	Panel	Duration
094	03:00	1	01:00

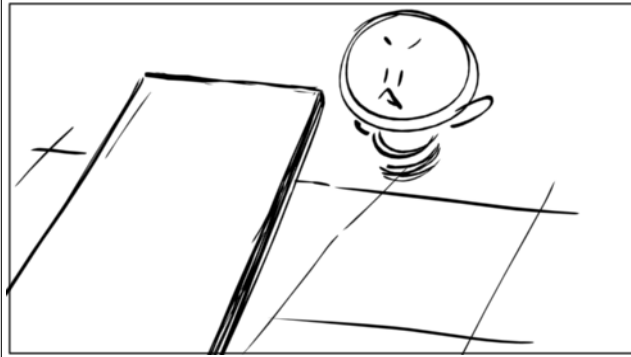

Scene	Duration	Panel	Duration
094	03:00	2	01:00

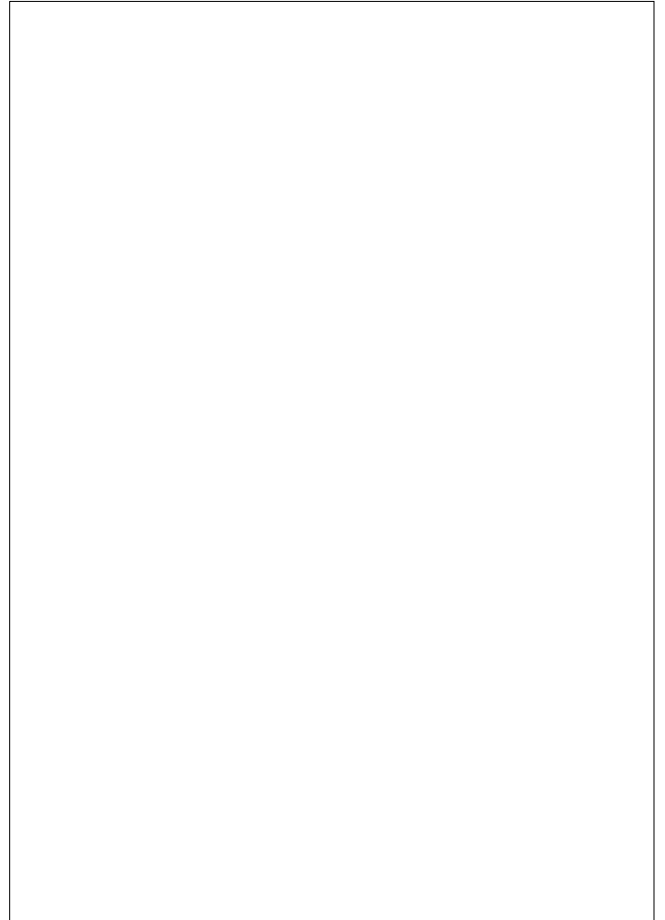
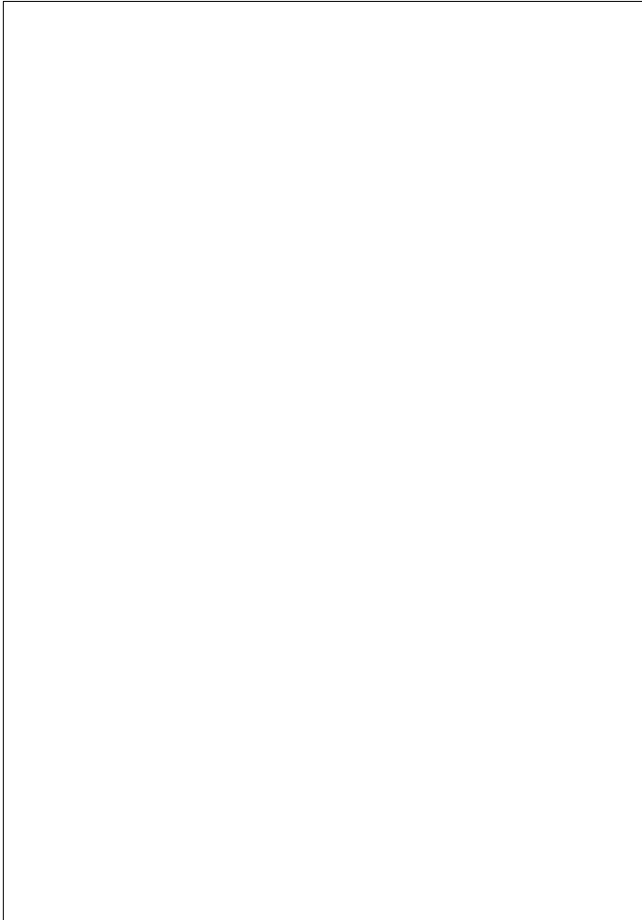
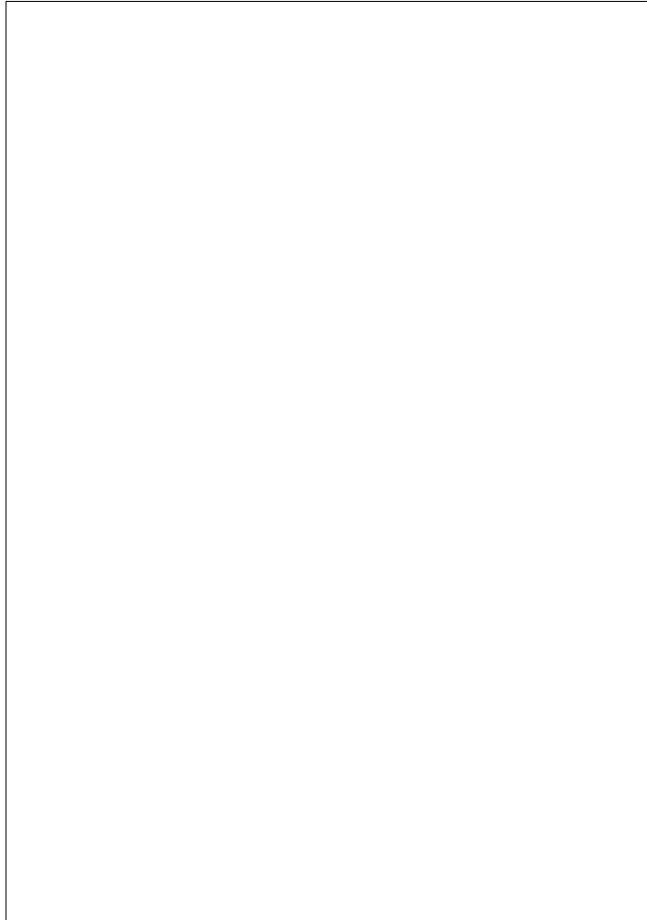
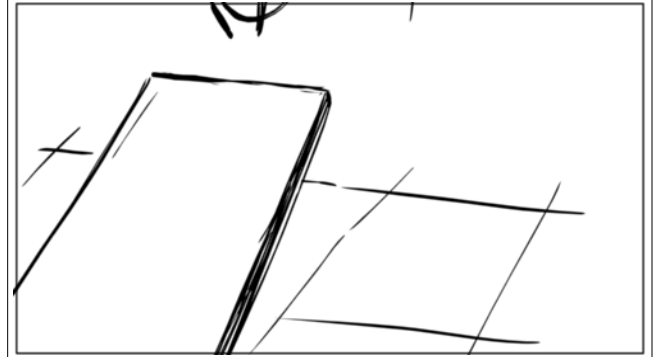



Scene	Duration	Panel	Duration
094	03:00	3	01:00

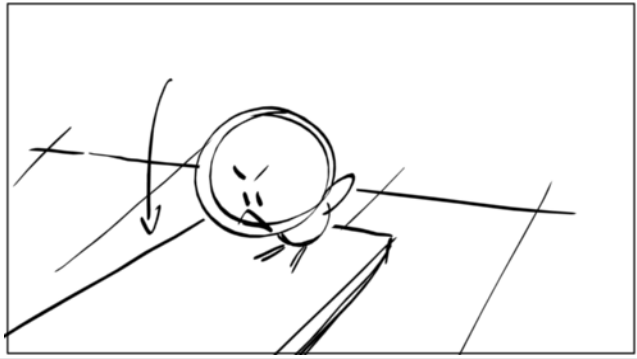

Scene	Duration	Panel	Duration
095	04:07	1	00:18

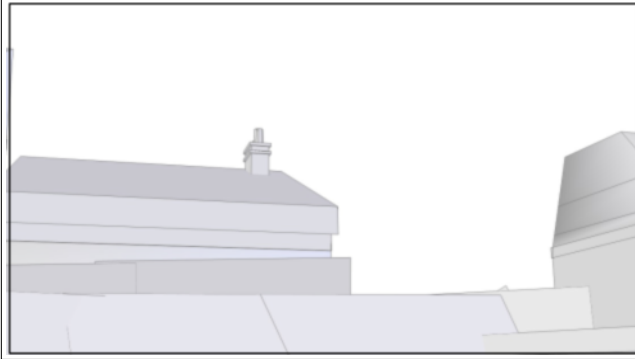

Scene	Duration	Panel	Duration
095	04:07	2	00:18

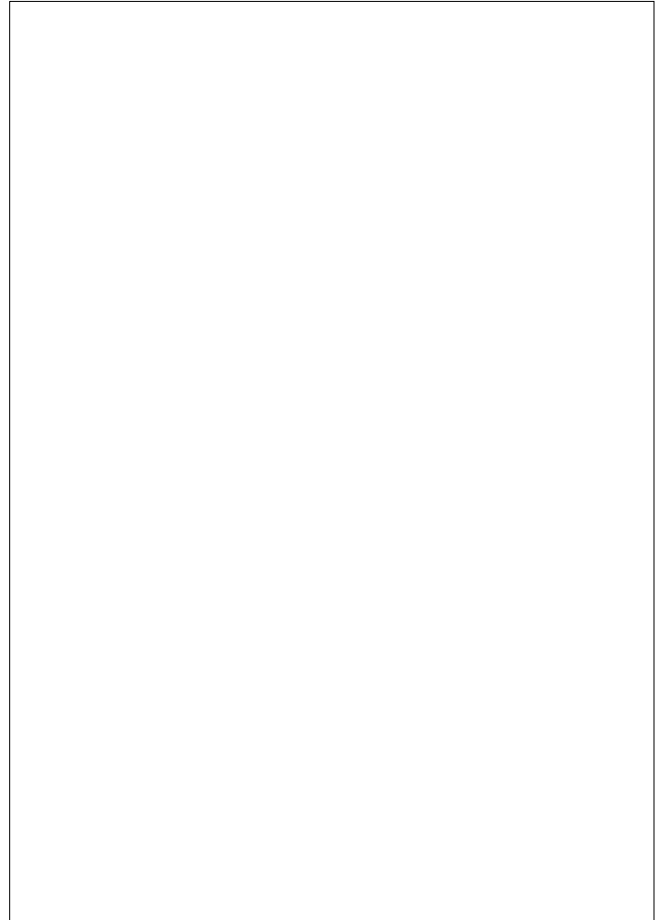
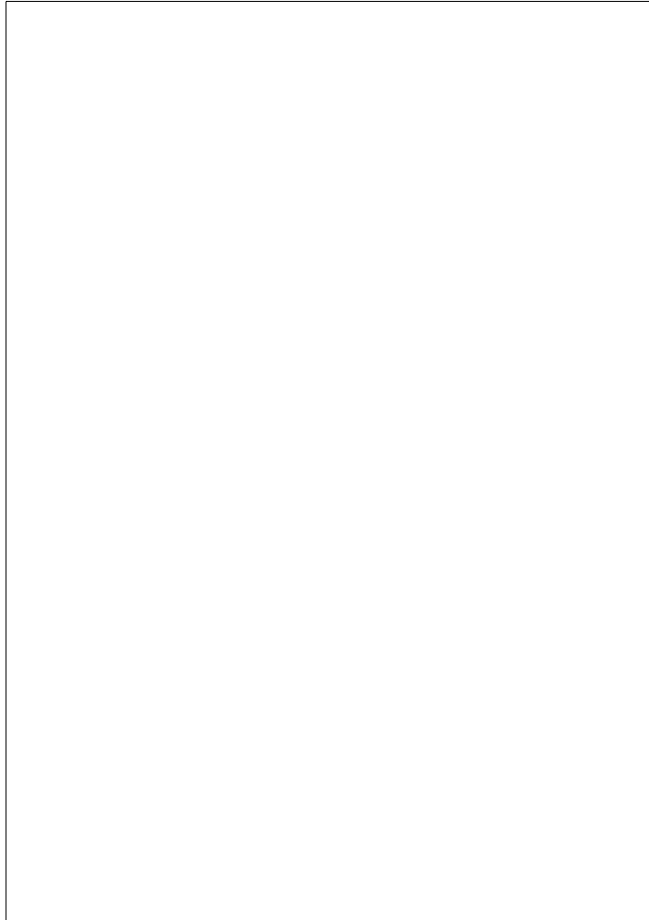



Scene	Duration	Panel	Duration
095	04:07	3	00:18

Scene	Duration	Panel	Duration
095	04:07	4	00:20

Scene	Duration	Panel	Duration
095	04:07	5	00:09

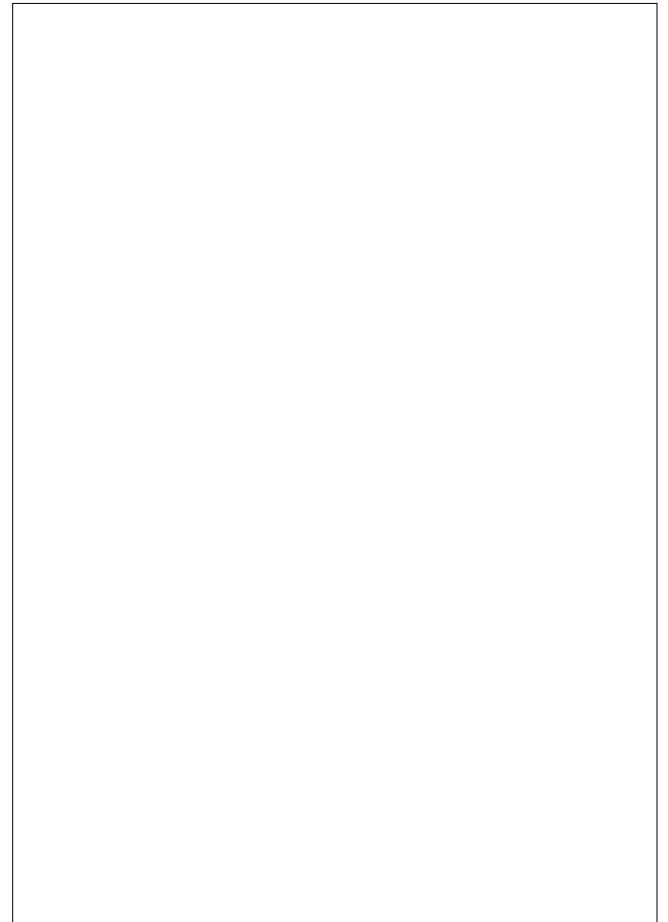
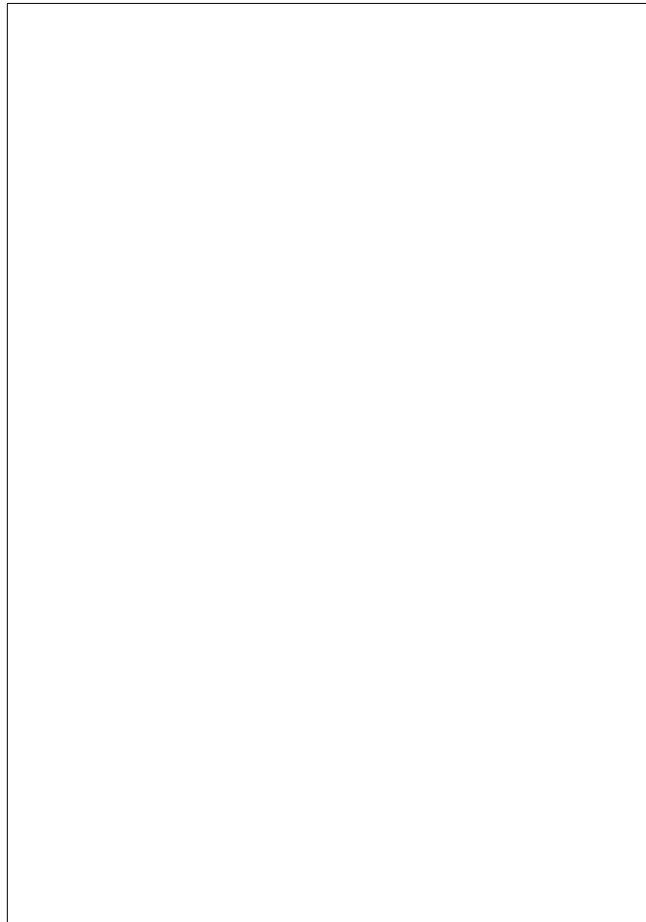
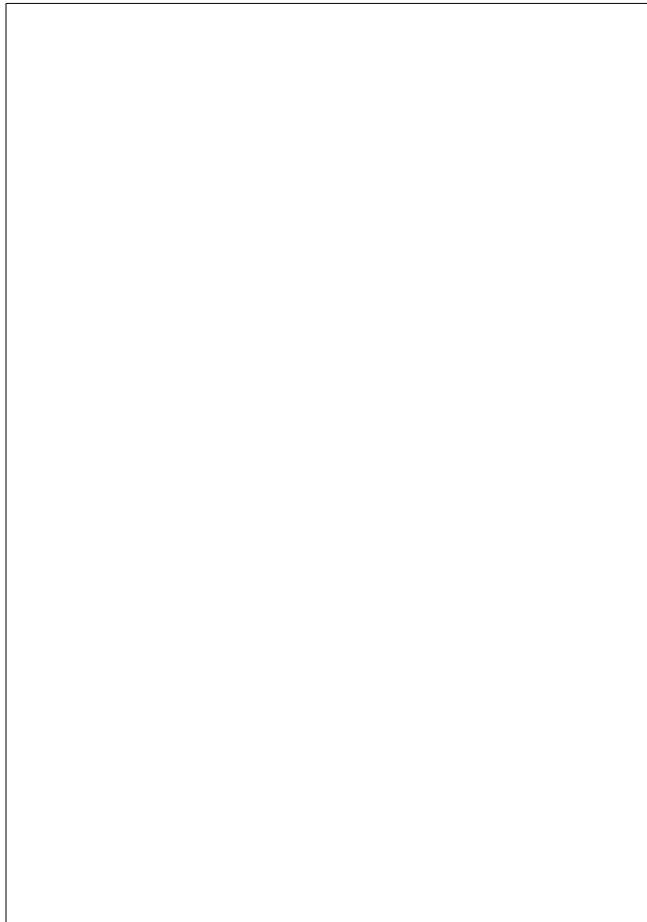
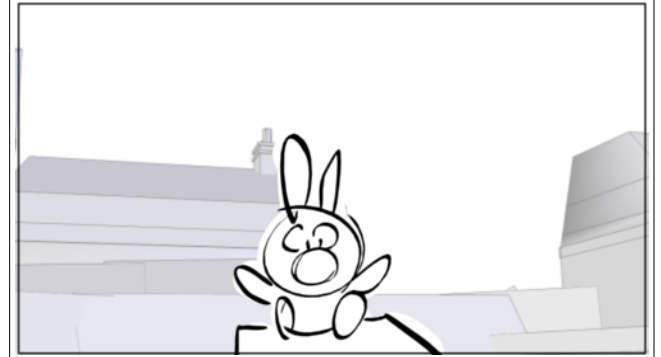



Scene	Duration	Panel	Duration
095	04:07	6	00:12

Scene	Duration	Panel	Duration
095	04:07	7	00:12

Scene	Duration	Panel	Duration
096	02:10	1	00:09

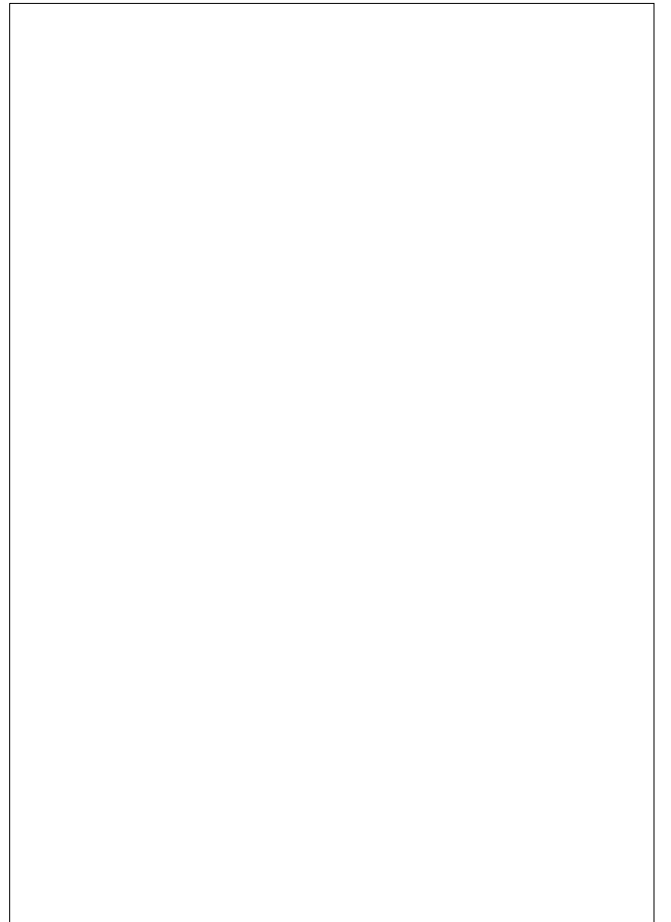
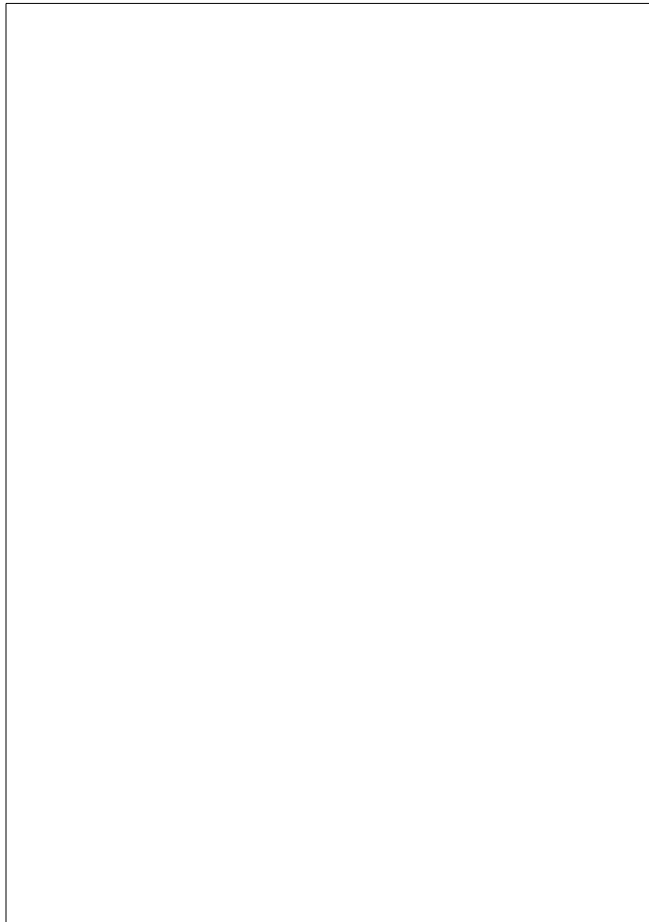
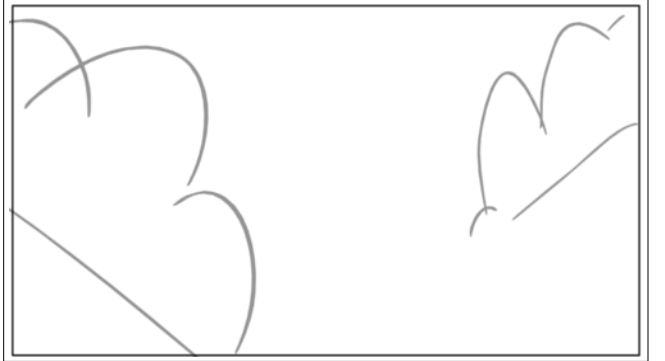
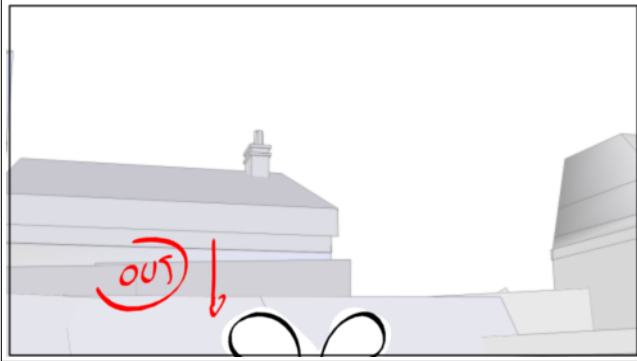
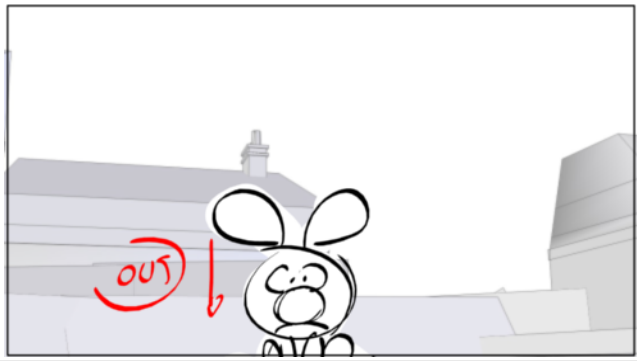



Scene	Duration	Panel	Duration
096	02:10	2	00:15

Scene	Duration	Panel	Duration
096	02:10	3	00:18

Scene	Duration	Panel	Duration
096	02:10	4	00:18

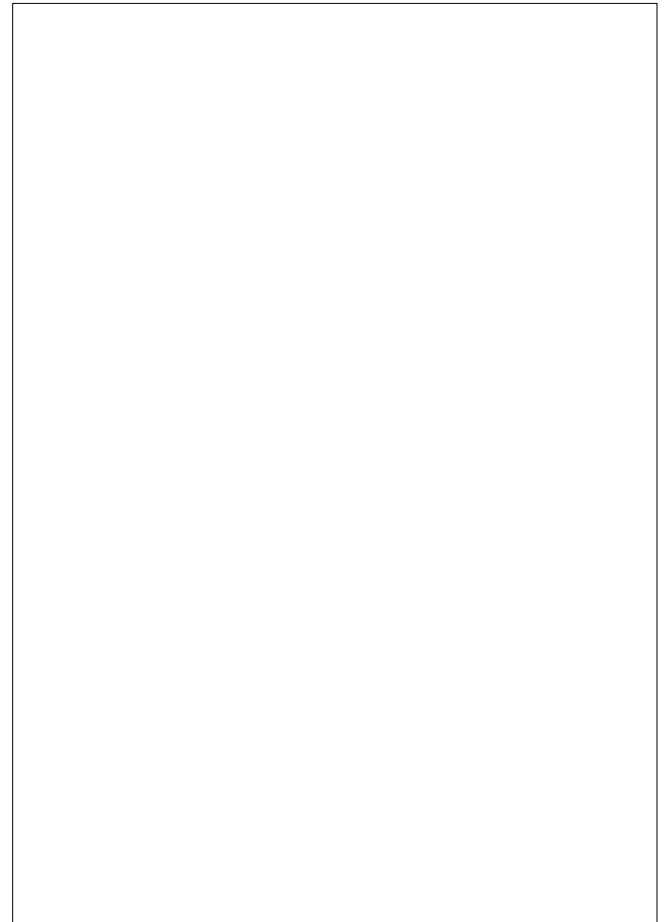
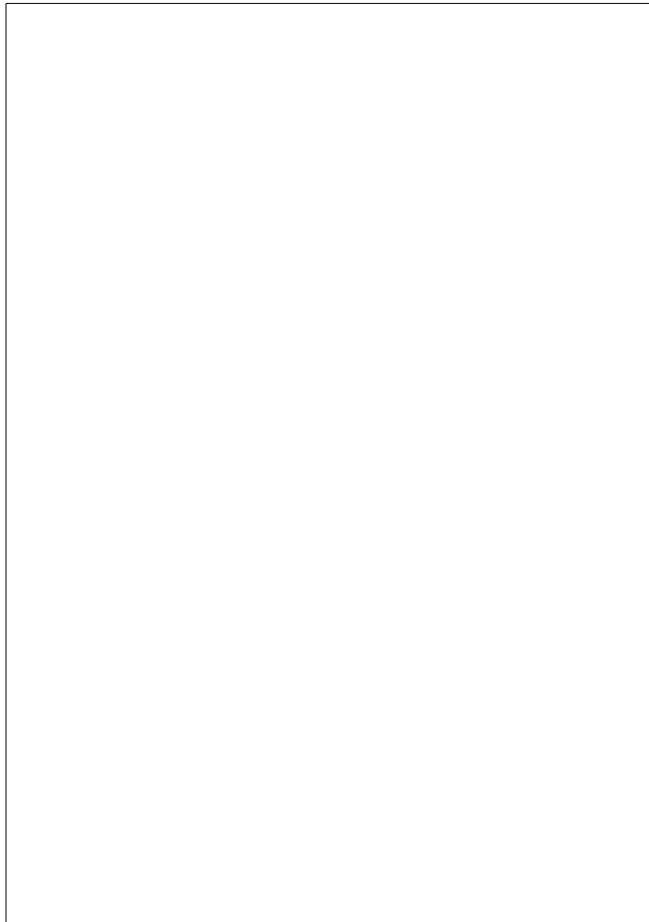
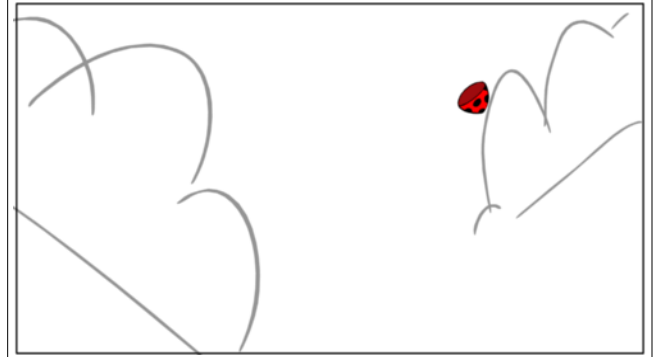
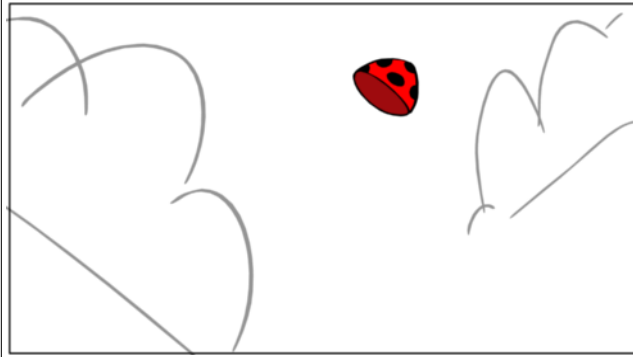
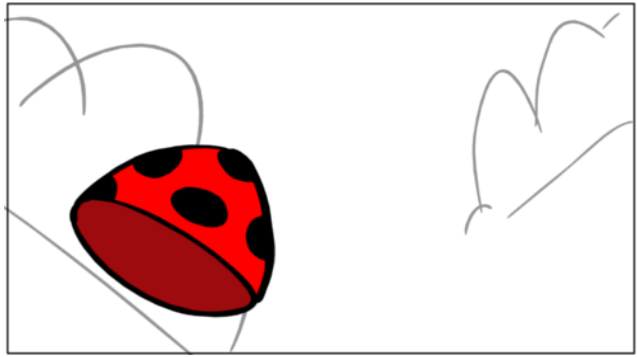



Scene	Duration	Panel	Duration
097	06:00	1	01:00

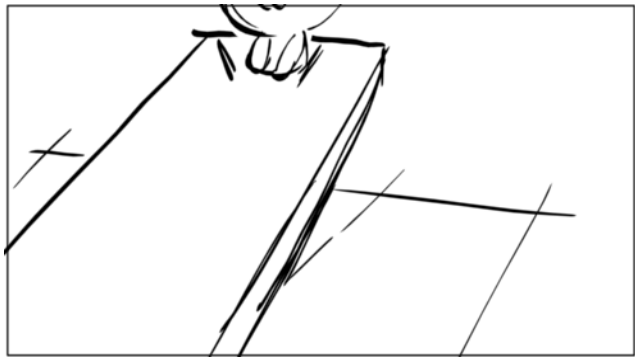

Scene	Duration	Panel	Duration
097	06:00	2	01:00

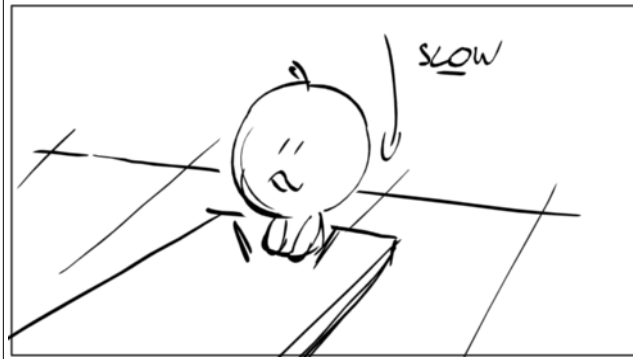

Scene	Duration	Panel	Duration
097	06:00	3	01:00

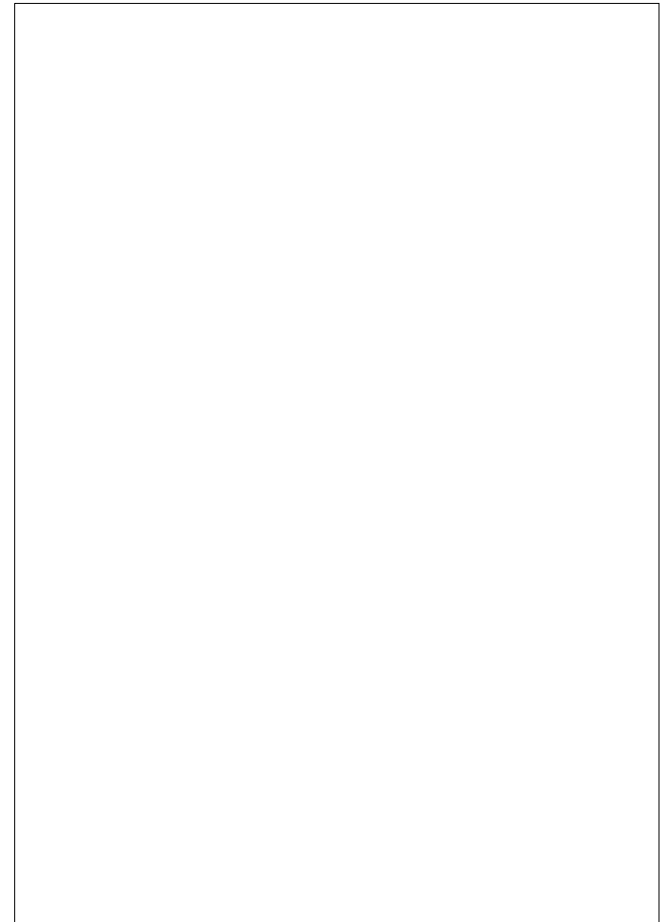
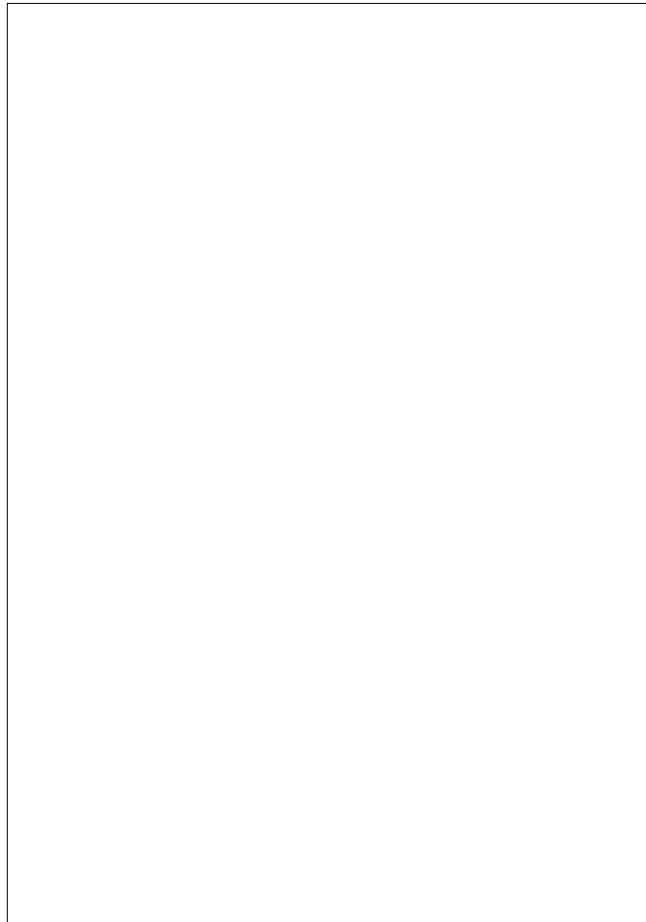
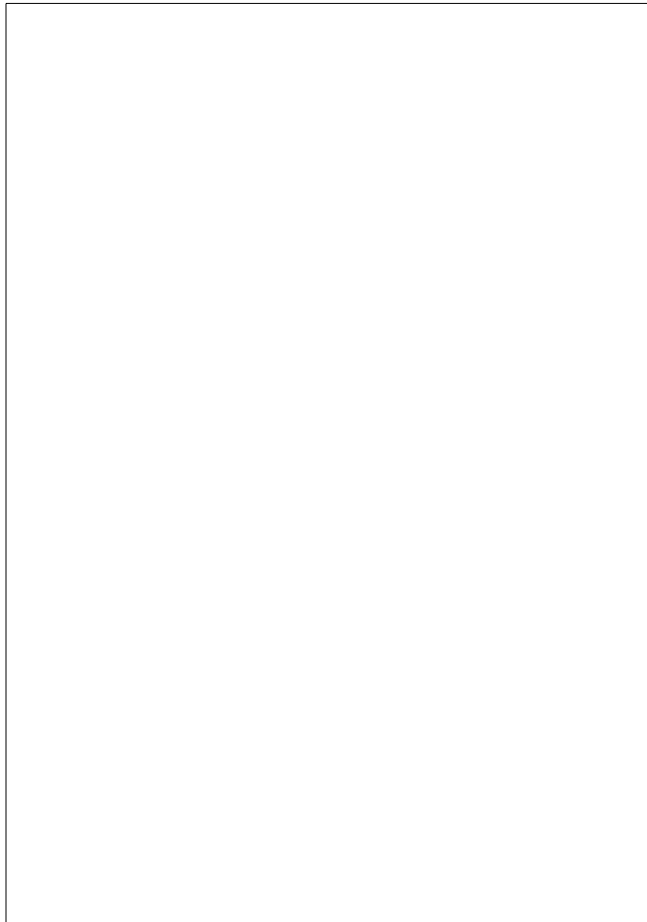



Scene	Duration	Panel	Duration
097	06:00	4	01:00

Scene	Duration	Panel	Duration
097	06:00	5	01:00

Scene	Duration	Panel	Duration
097	06:00	6	01:00

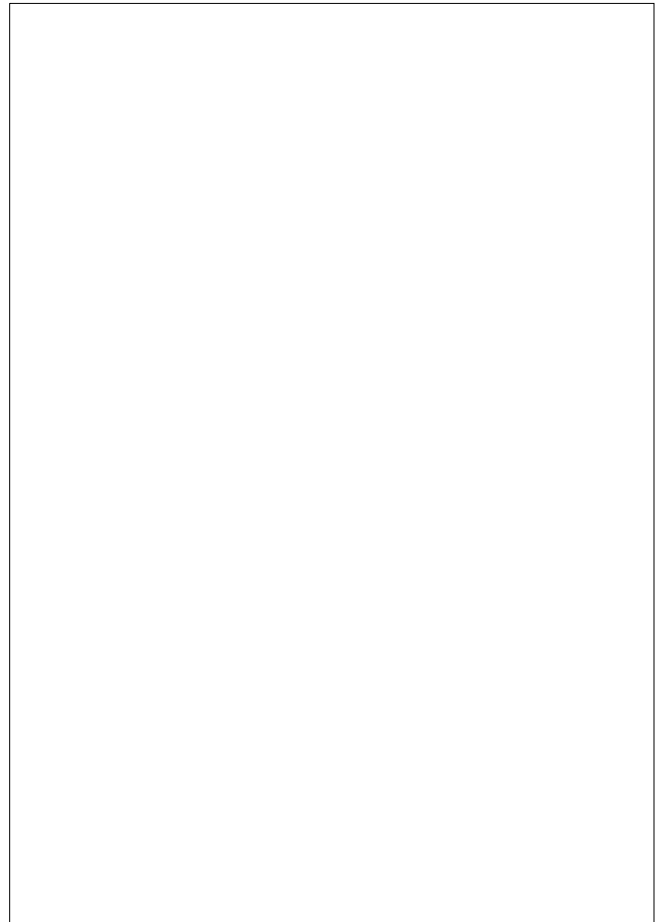
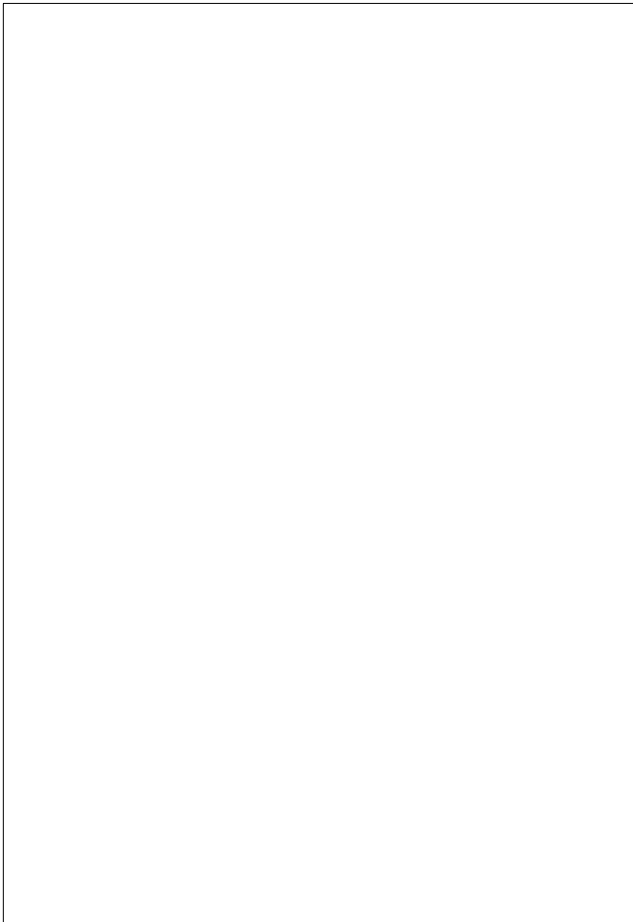
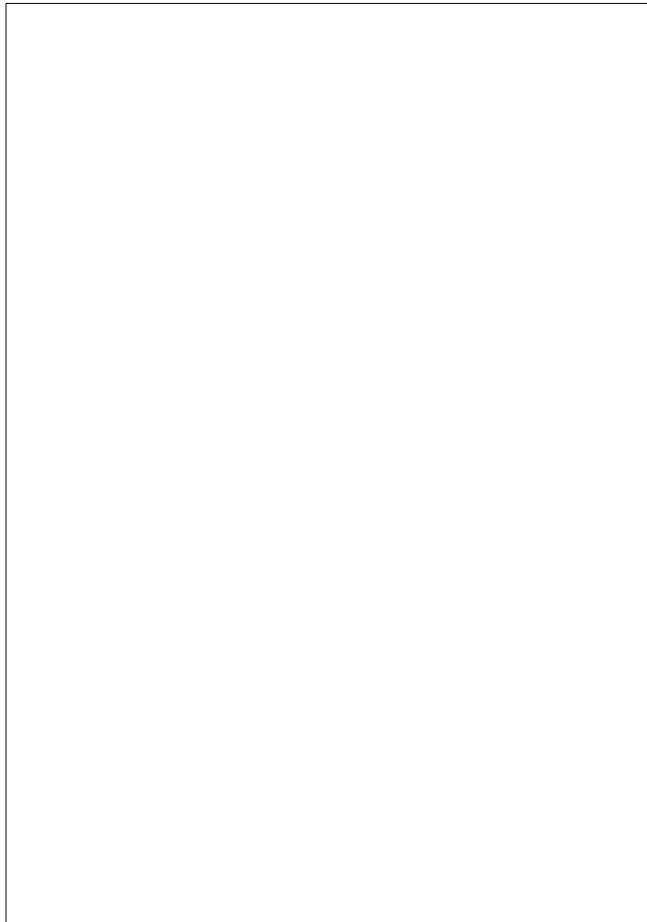
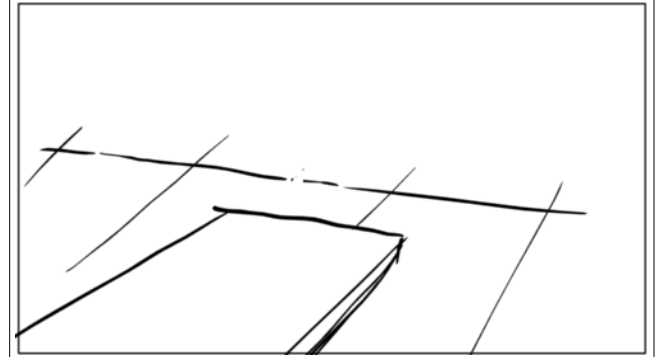
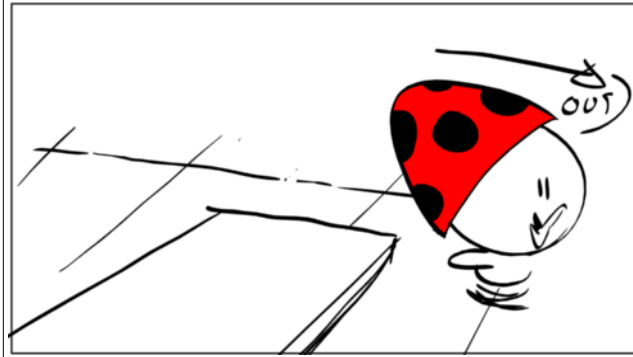

Scene	Duration	Panel	Duration
098	04:21	1	01:00



Scene	Duration	Panel	Duration
098	04:21	2	01:00

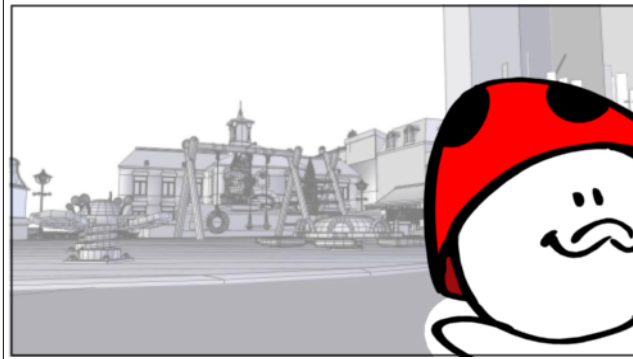

Scene	Duration	Panel	Duration
098	04:21	3	01:00

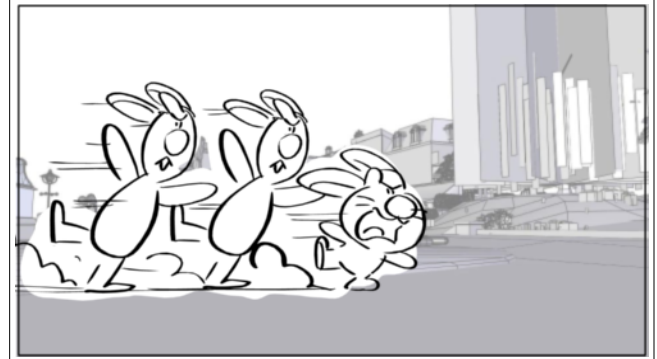

Dialogue

55. POT (énervé, hélant ses cousins)
Rattrapons-le,

Scene	Duration	Panel	Duration
098	04:21	4	01:00

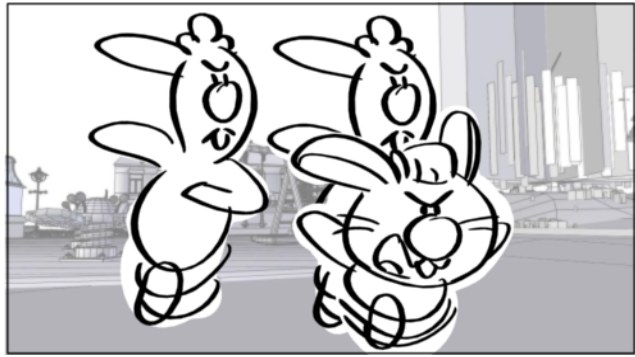

Dialogue

55. POT (énervé, hélant ses cousins)
il va me le payer !

Scene	Duration	Panel	Duration
098	04:21	5	00:11



Dialogue

55. POT (énervé, hélant ses cousins)
il va me le payer !

Scene	Duration	Panel	Duration
098	04:21	6	00:10



Dialogue

55. POT (énervé, hélant ses cousins)
il va me le payer !



Scene	Duration	Panel	Duration
099	05:00	1	01:00

Scene	Duration	Panel	Duration
099	05:00	2	01:00

Scene	Duration	Panel	Duration
099	05:00	3	01:00

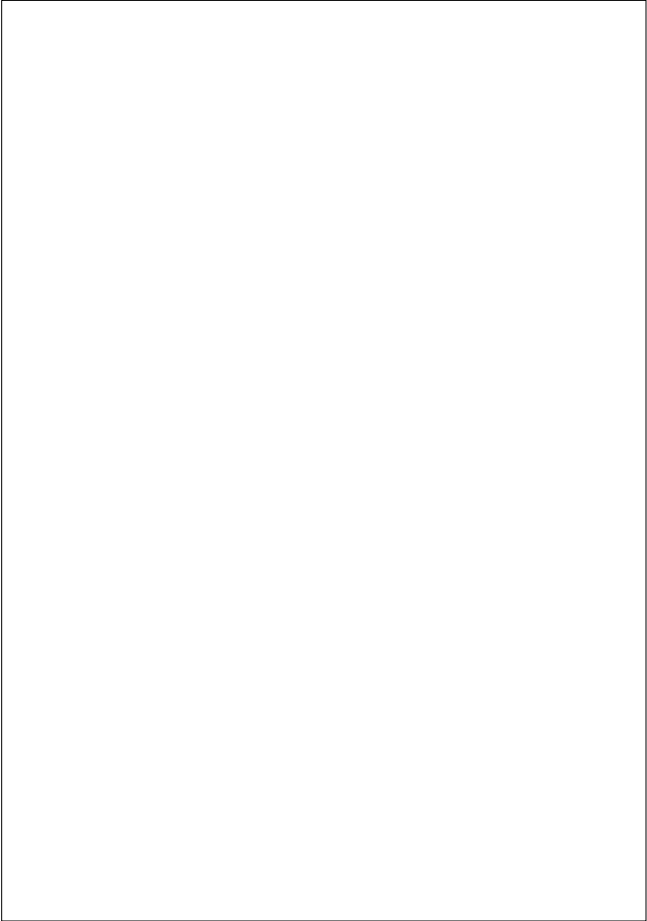
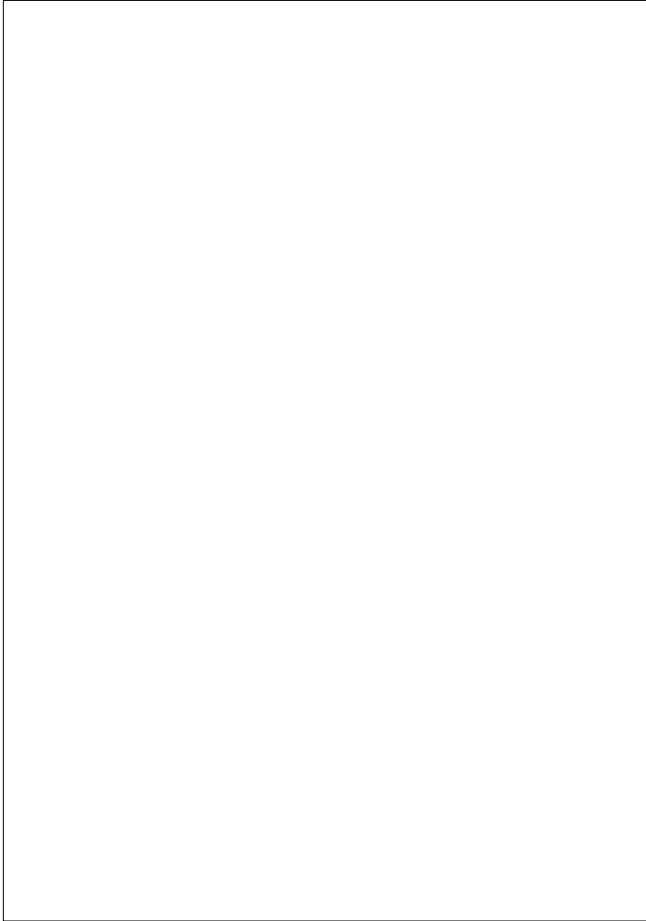



Scene	Duration	Panel	Duration
099	05:00	4	01:00

Scene	Duration	Panel	Duration
099	05:00	5	01:00

Scene	Duration	Panel	Duration
100	09:20	1	01:00

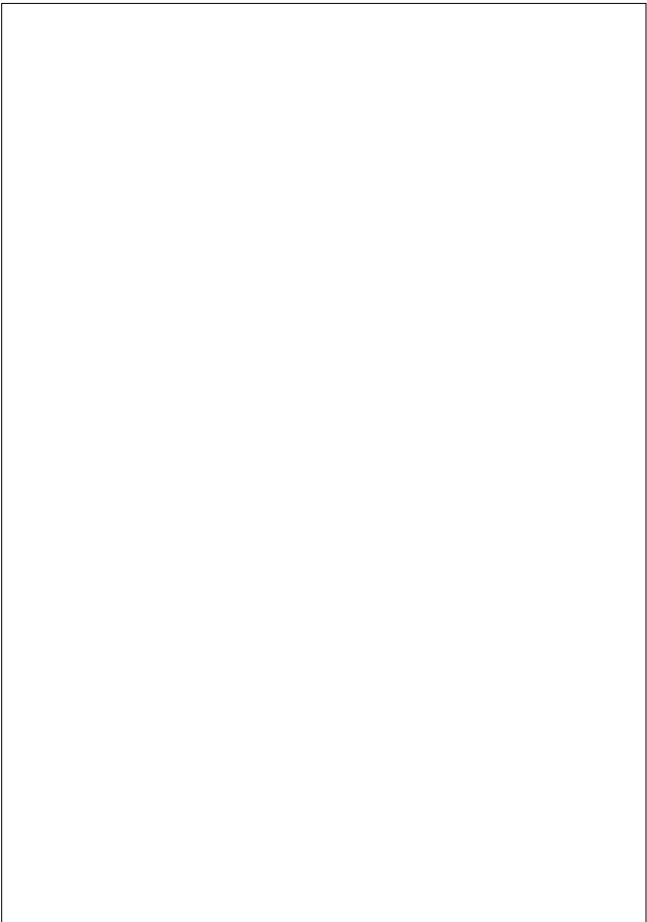
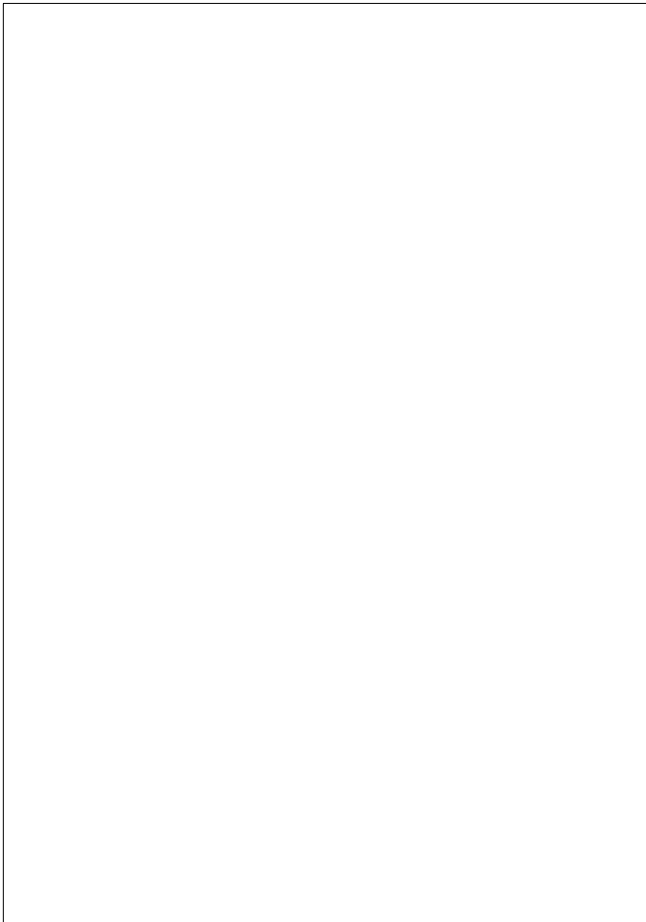
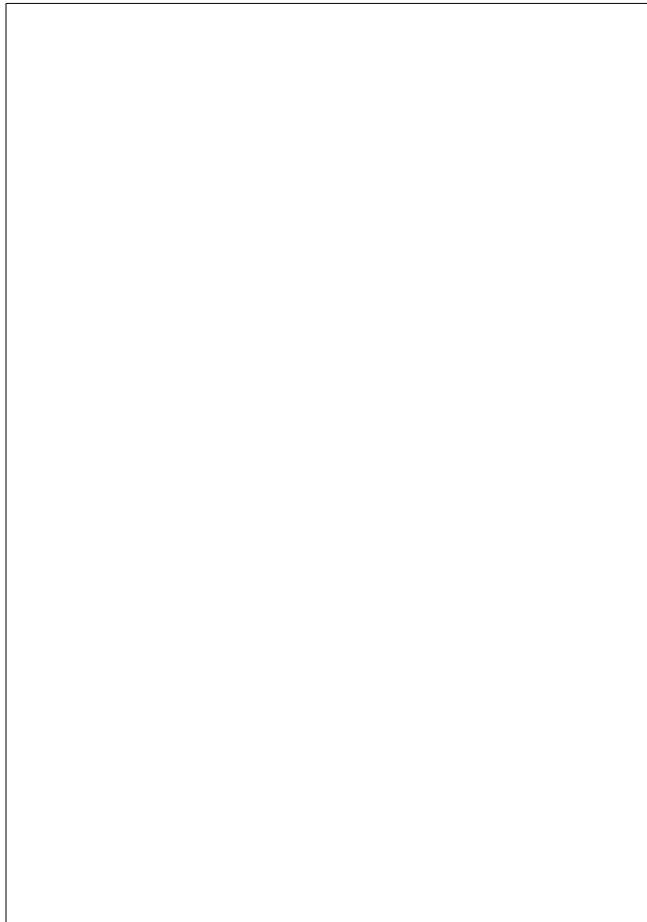
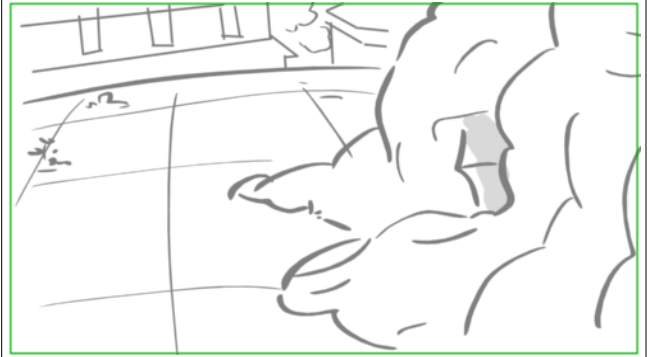
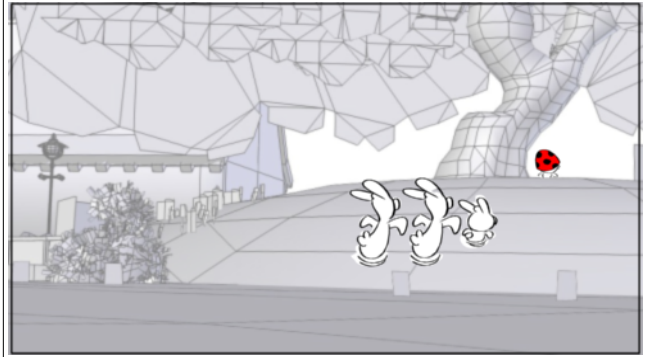

Scene	Duration	Panel	Duration
100	09:20	2	01:00

Scene	Duration	Panel	Duration
100	09:20	3	01:00

Scene	Duration	Panel	Duration
100	09:20	4	00:18

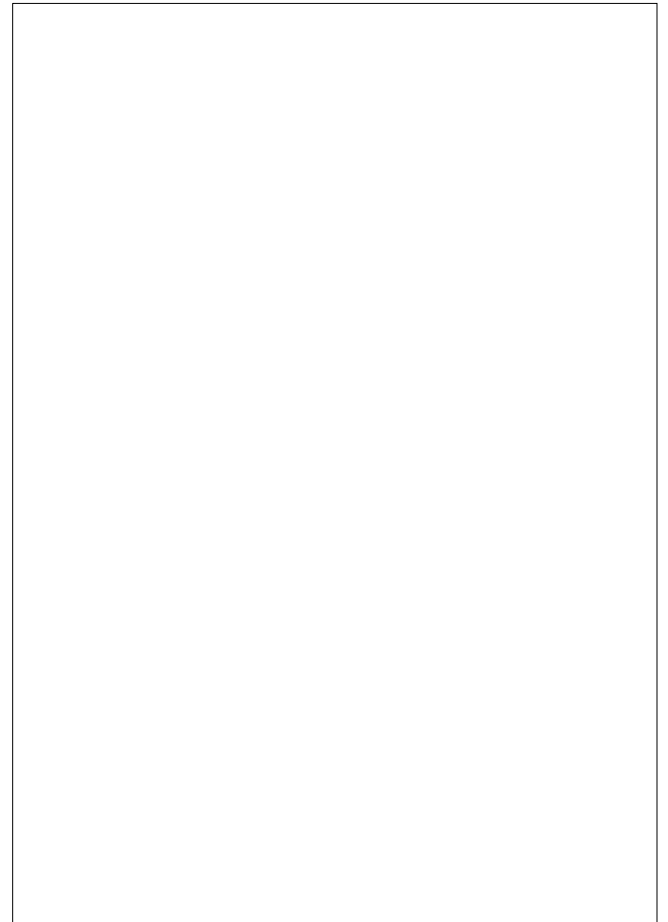
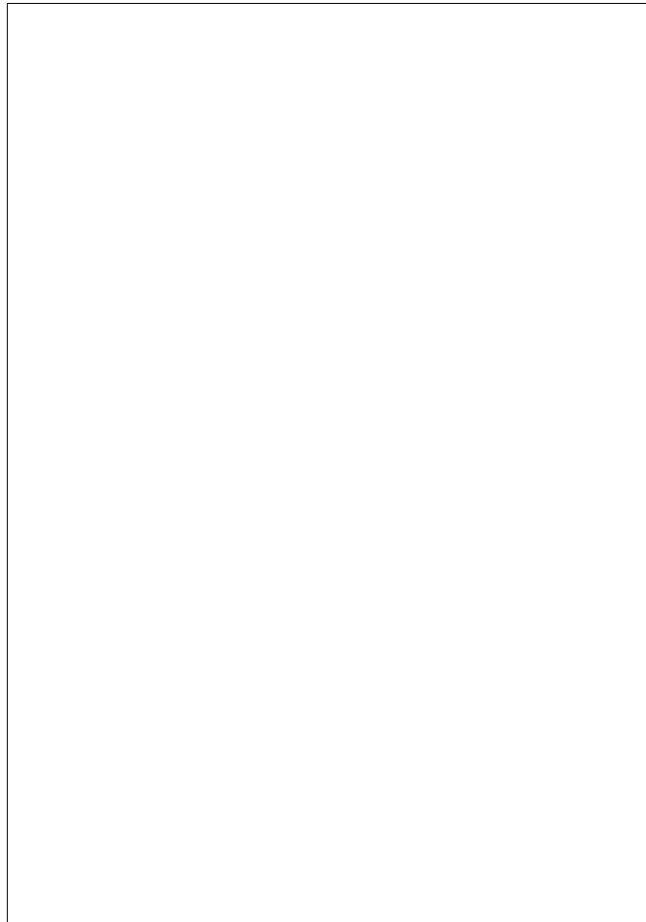
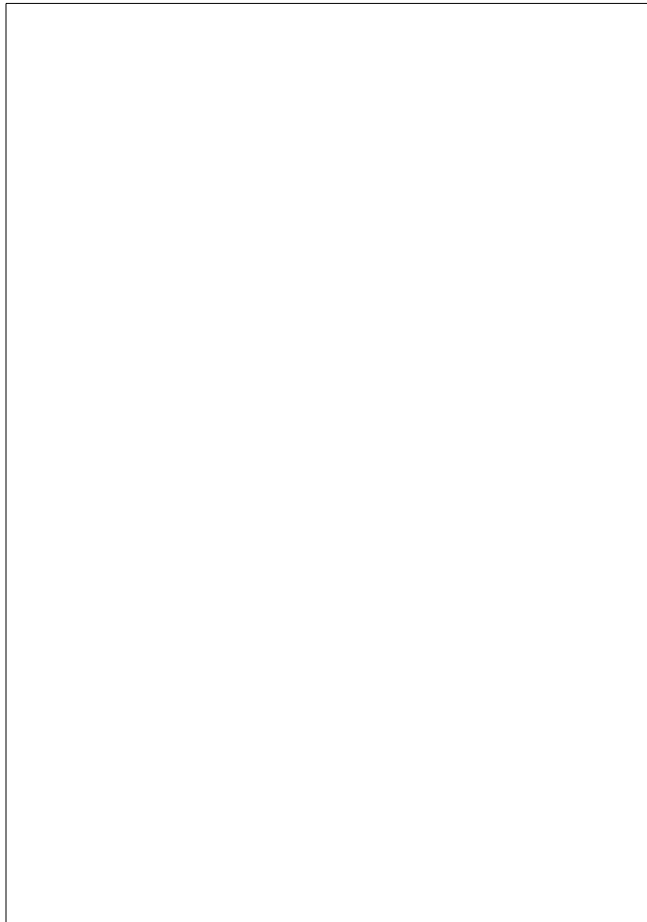
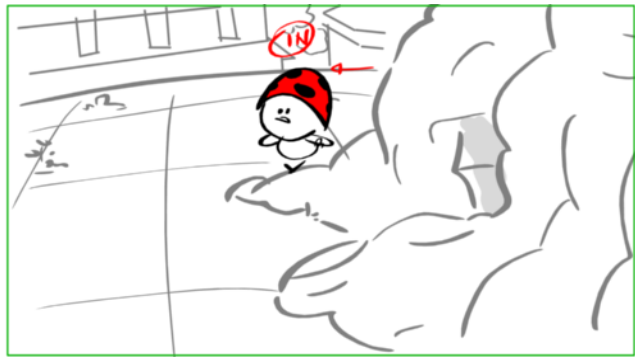



Scene	Duration	Panel	Duration
100	09:20	5	00:14

Scene	Duration	Panel	Duration
100	09:20	6	01:00

Scene	Duration	Panel	Duration
100	09:20	7	01:00

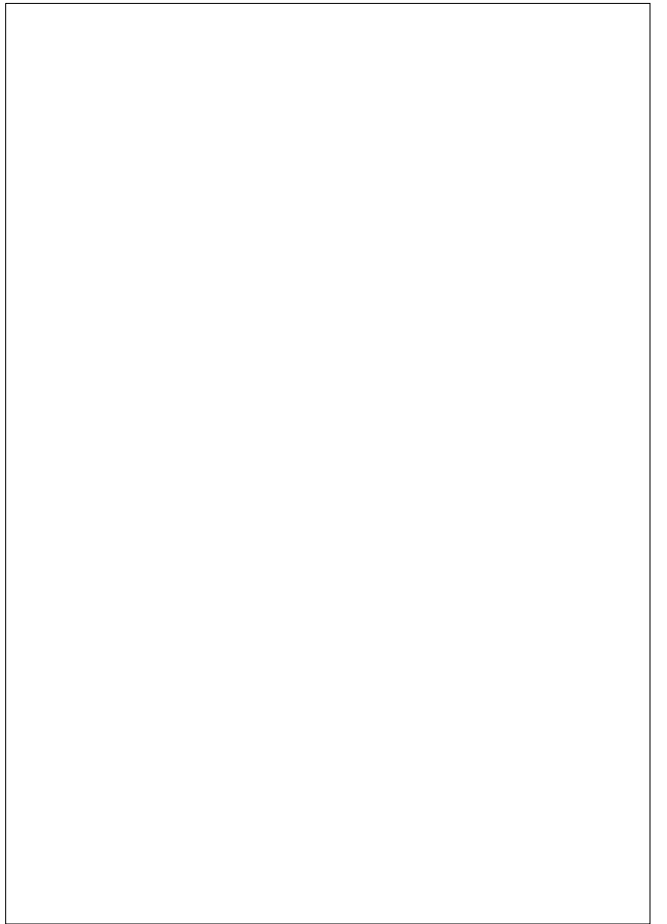
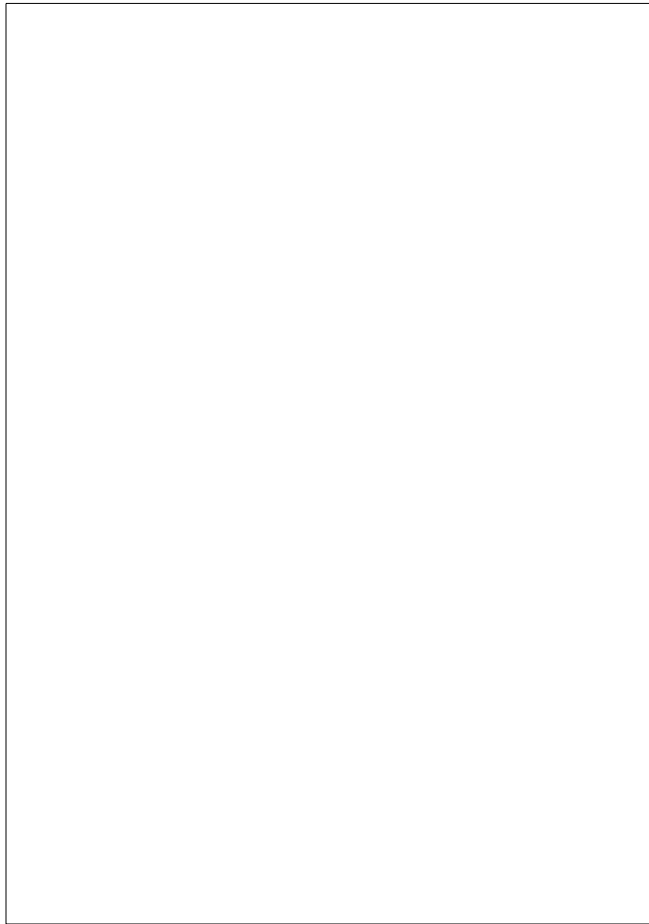
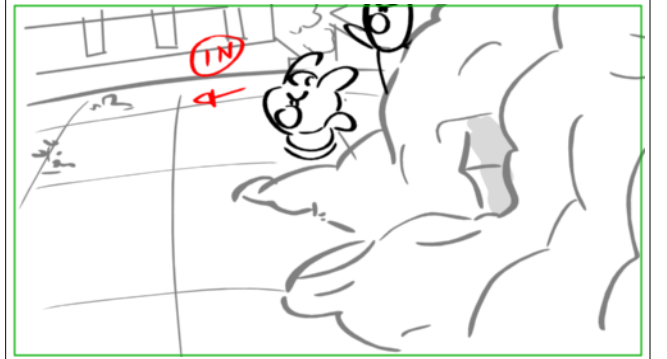
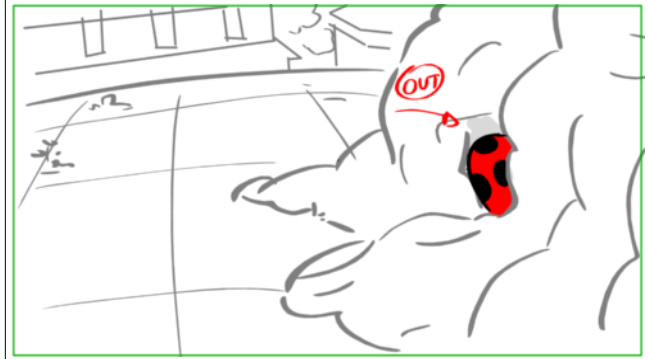
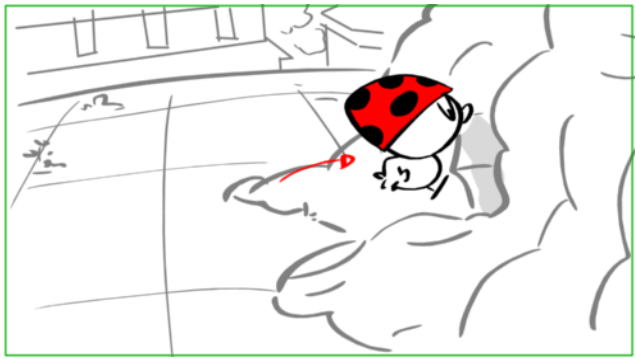



Scene	Duration	Panel	Duration
100	09:20	8	01:00

Scene	Duration	Panel	Duration
100	09:20	9	01:00

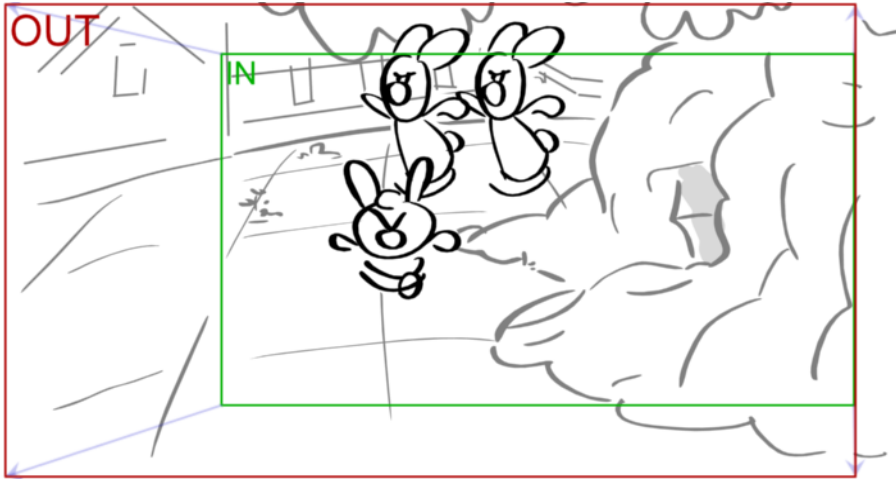



Scene	Duration	Panel	Duration
100	09:20	10	00:13

Scene	Duration	Panel	Duration
100	09:20	11	00:12

Scene	Duration	Panel	Duration
100	09:20	12	00:13

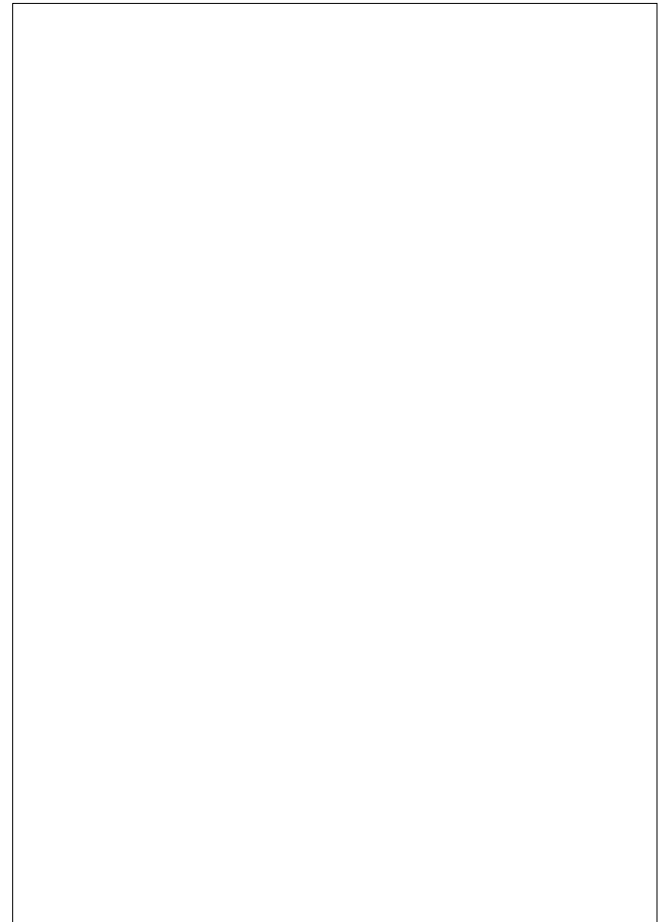
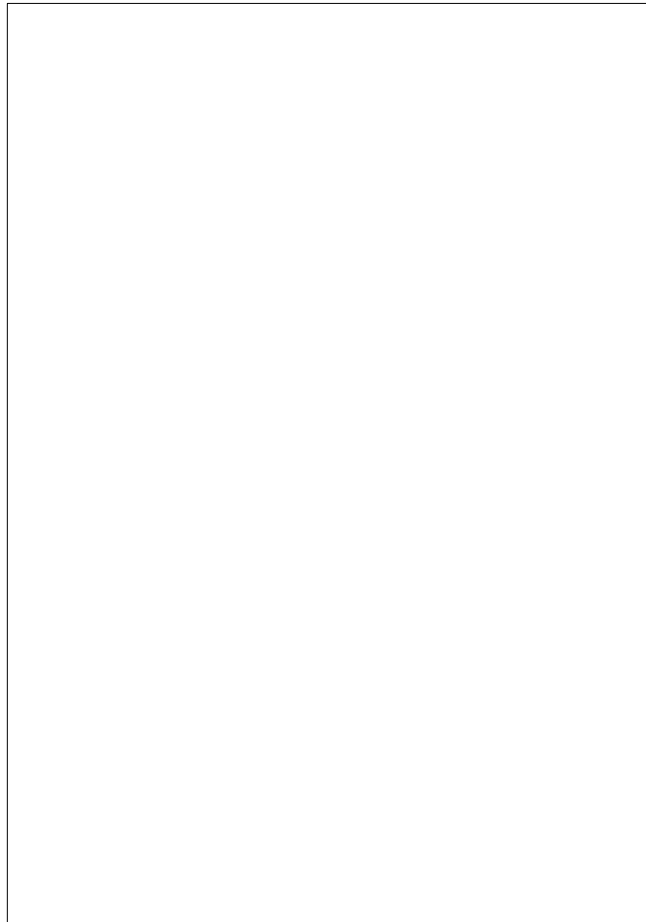
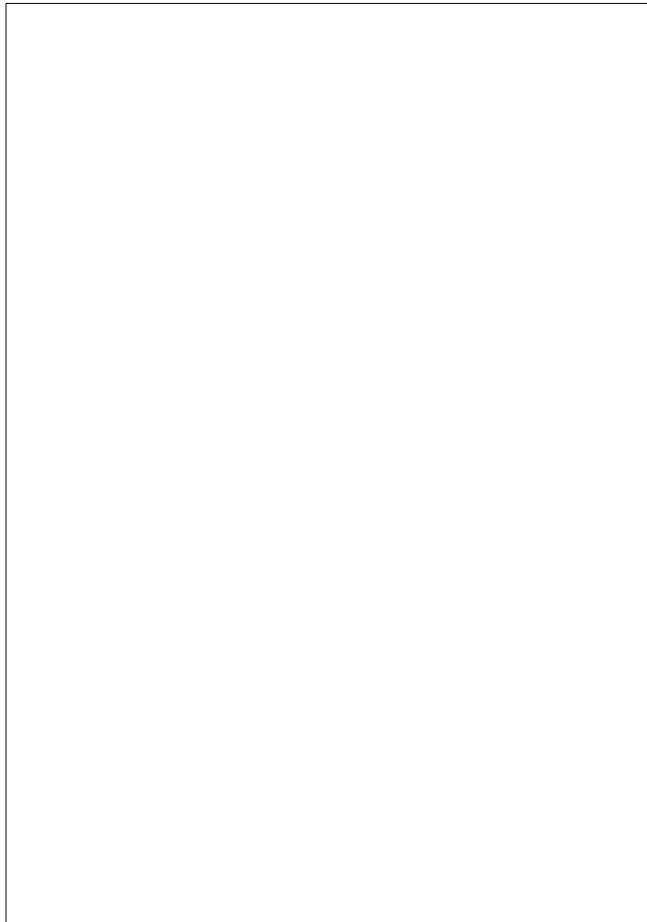

Scene	Duration	Panel	Duration
101	03:18	1	01:00



Dialogue
 56. POT (agacé)
 Non d'une carotté râpée, il a filé!

Scene	Duration	Panel	Duration
101	03:18	2	02:18



Dialogue
 56. POT (agacé)
 Non d'une carotté râpée, il a filé!

Scene	Duration	Panel	Duration
102	05:03	1	01:16





Scene	Duration	Panel	Duration
102	05:03	2	03:12



Dissolve	Duration
	00:24

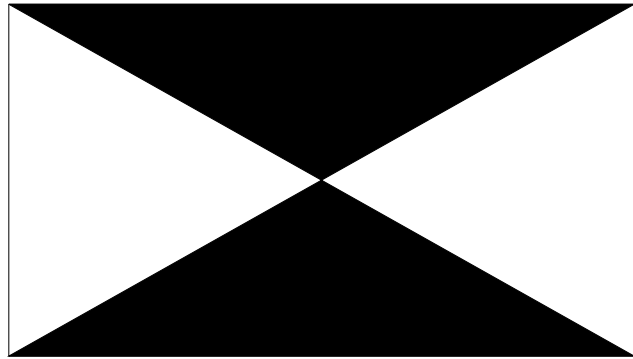

Scene	Duration	Panel	Duration
103	02:24	1	02:24

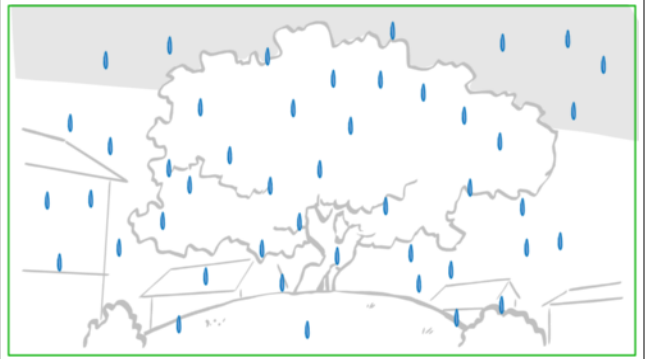

Action Notes

fx pluie



Scene	Duration	Panel	Duration
104	03:17	1	03:17

NO PANEL

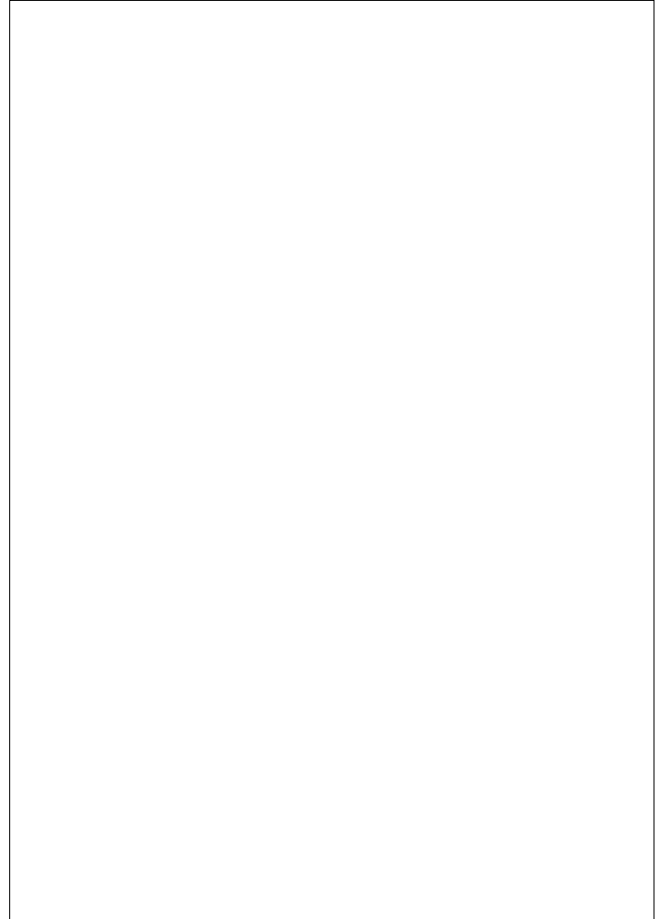
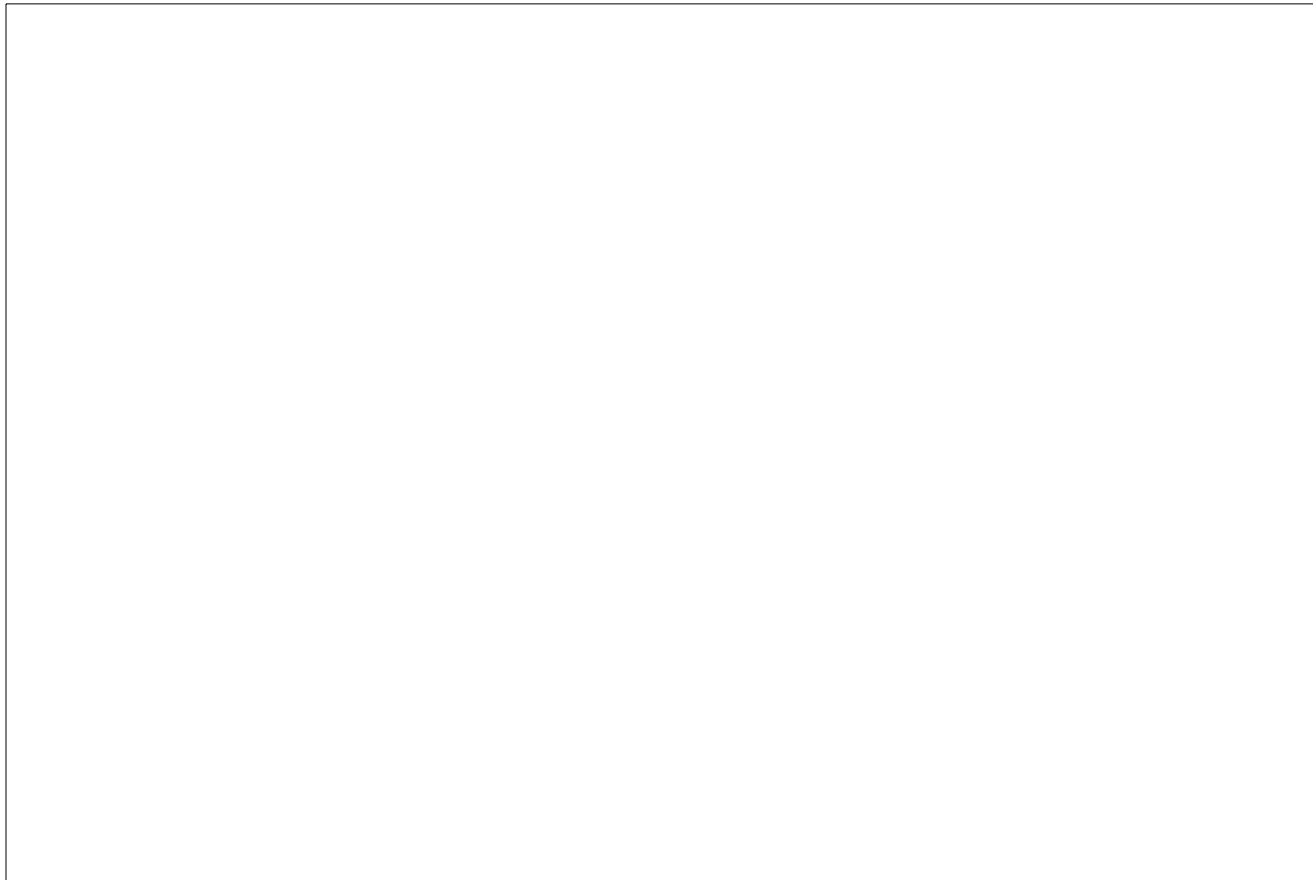
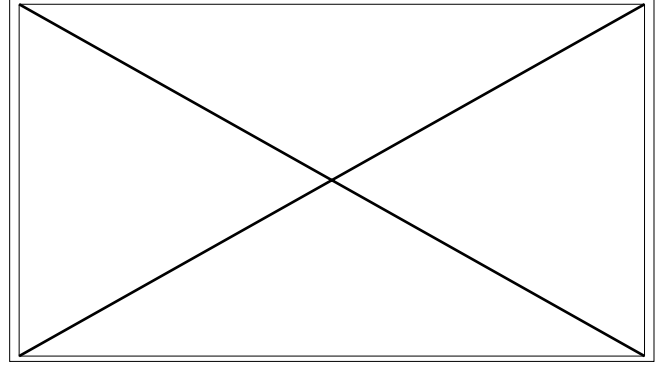



Scene	Duration	Panel	Duration
105	04:02	1	01:13

NO PANEL

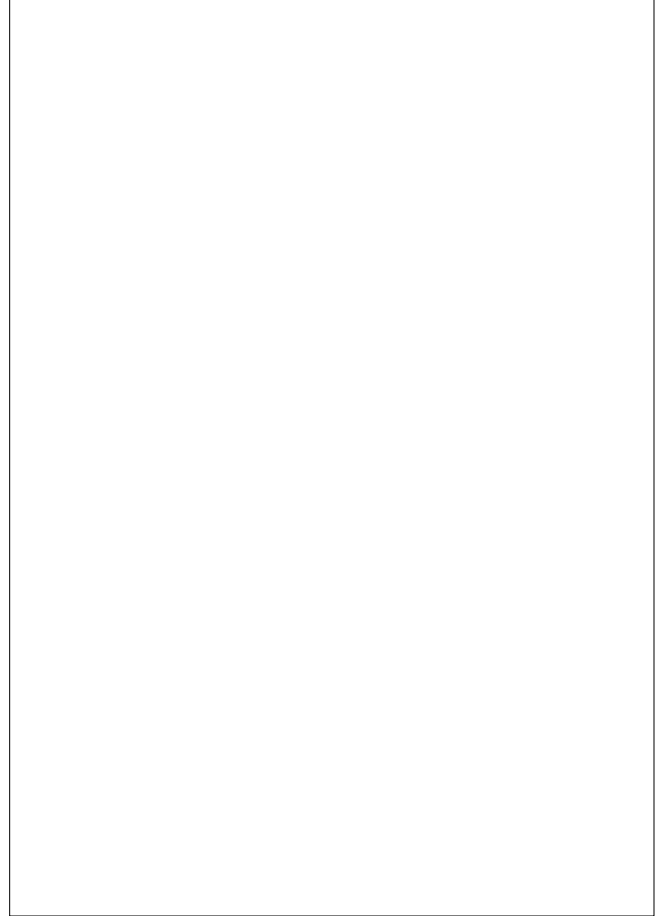
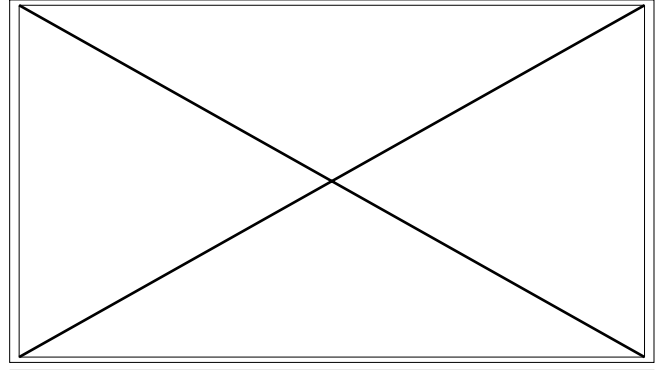

Scene	Duration	Panel	Duration
105	04:02	2	02:14

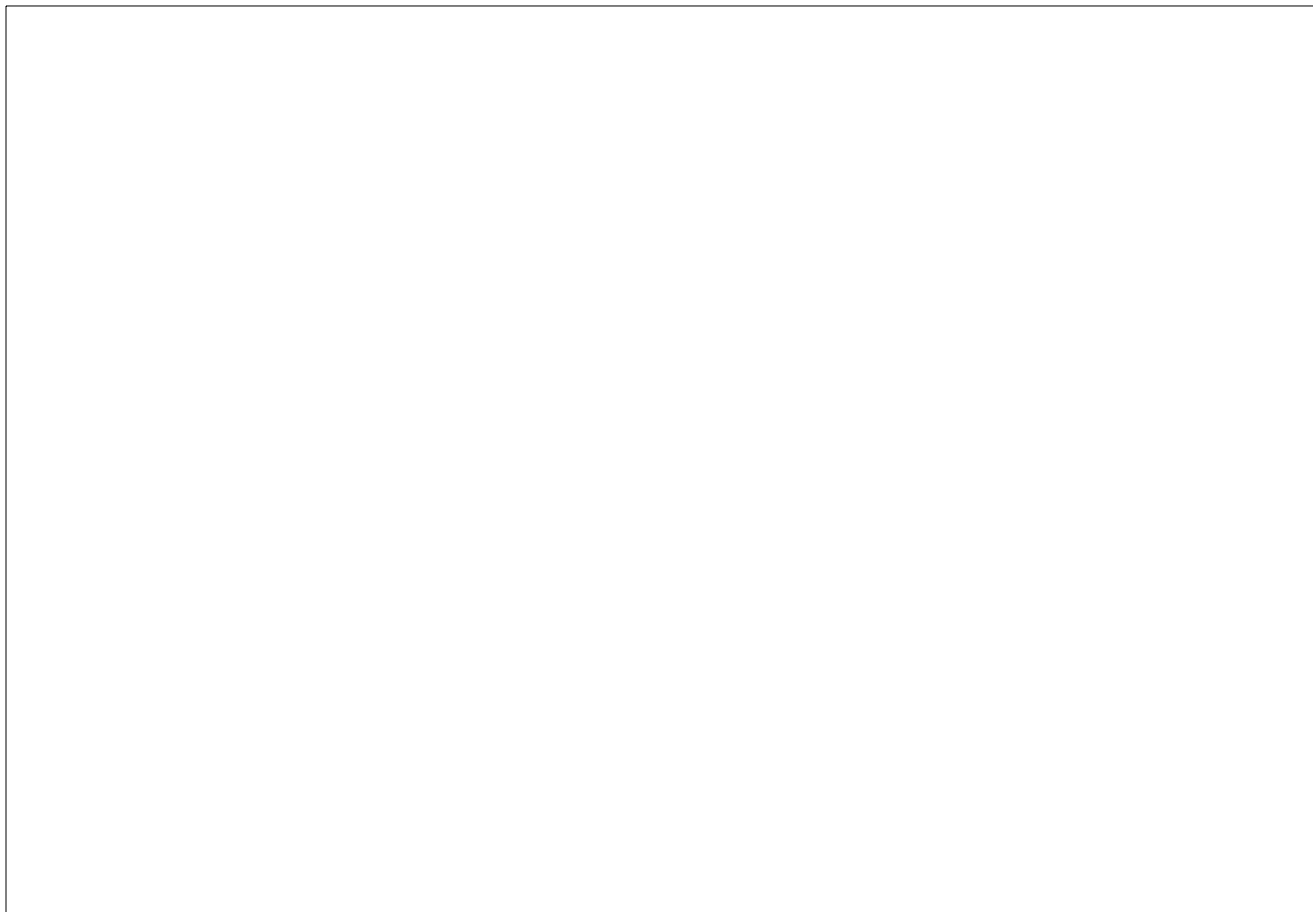

Scene	Duration	Panel	Duration
106	04:16	1	02:07

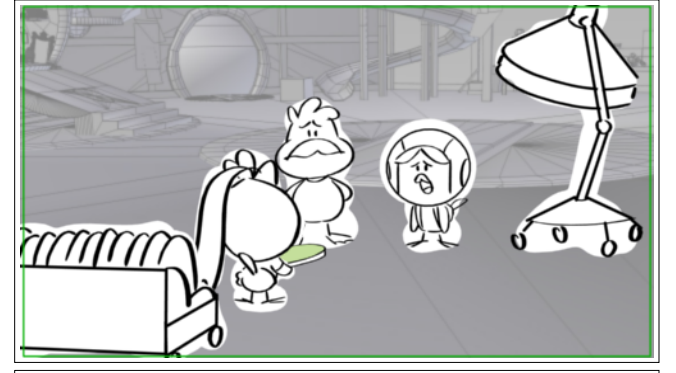

Action Notes
 6. MOULIN, ATELIER DE DO VINCI. INT/JOUR

Scene	Duration	Panel	Duration
106	04:16	2	01:23

Scene	Duration	Panel	Duration
106	04:16	3	00:11

Scene	Duration	Panel	Duration
107	01:16	1	00:11

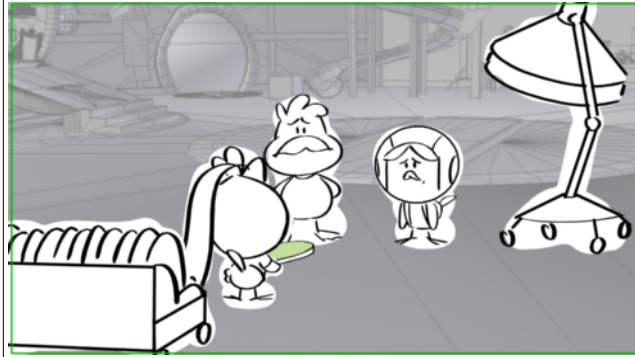
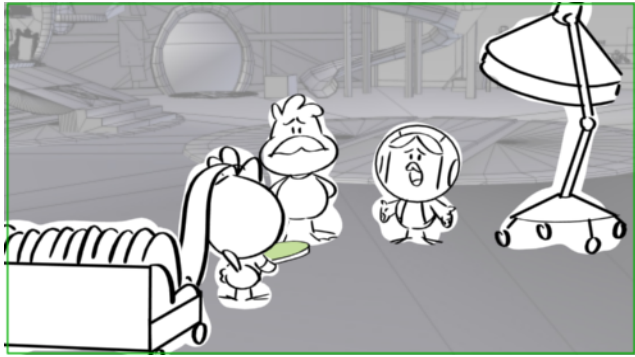

Dialogue
 PICK UP VALERIANO / PIERROT
 Tiens! Salut Priscilla!

Dialogue
 PICK UP VALERIANO / PIERROT
 Tiens! Salut Priscilla!



Scene	Duration	Panel	Duration
107	01:16	2	01:05

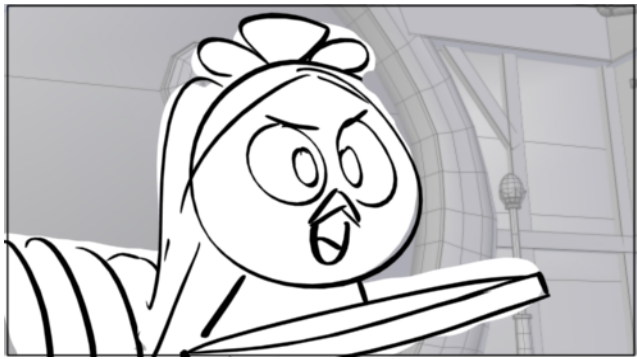

Scene	Duration	Panel	Duration
108	03:00	1	01:00

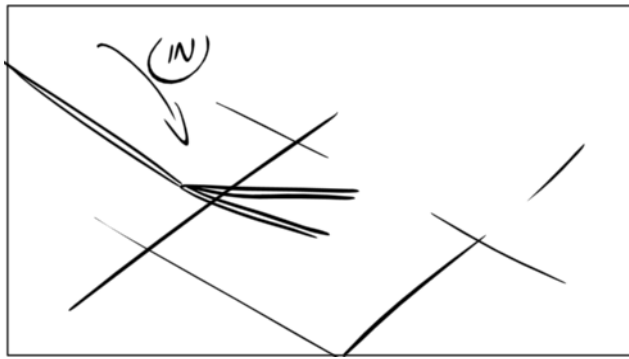

Scene	Duration	Panel	Duration
108	03:00	2	01:00

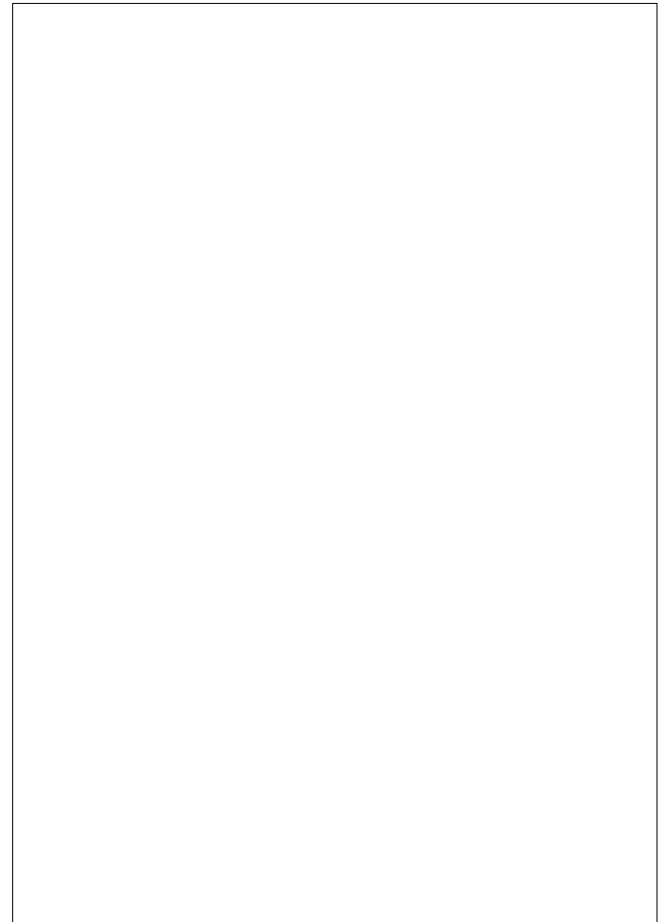
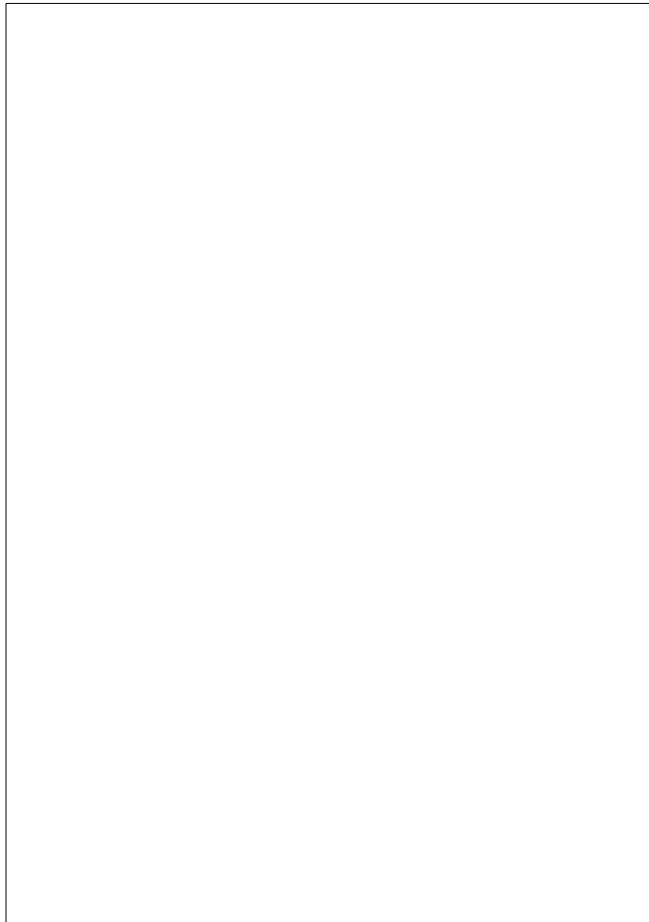
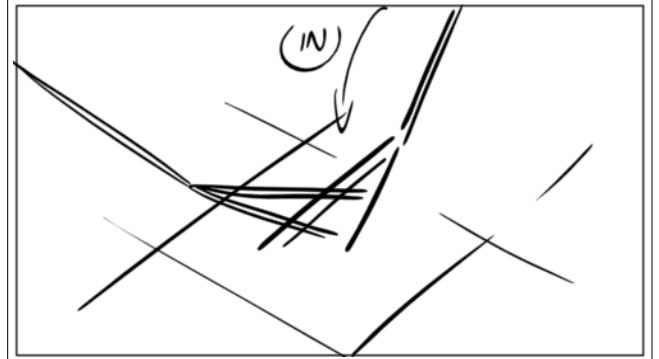

Scene	Duration	Panel	Duration
108	03:00	3	01:00

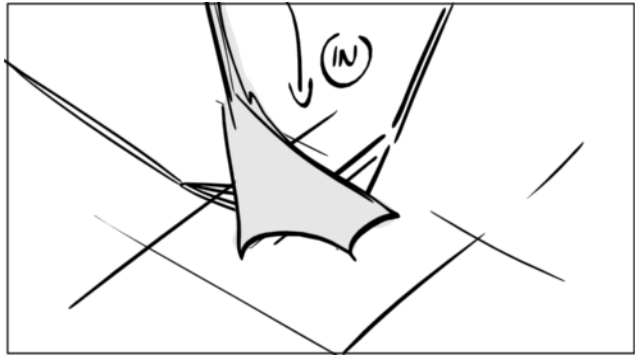

Scene	Duration	Panel	Duration
109	01:15	1	01:15

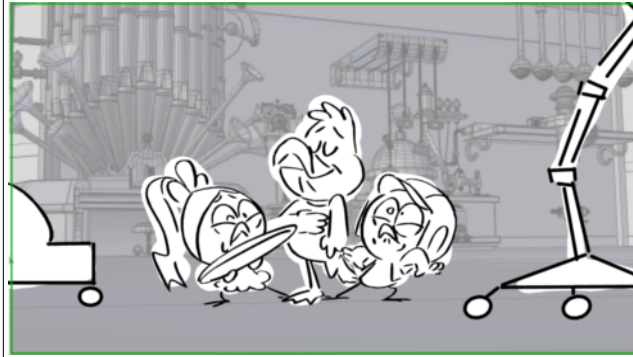

Scene	Duration	Panel	Duration
110	02:04	1	02:04

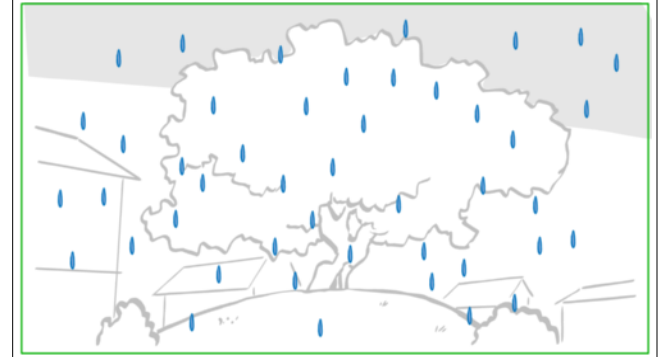

Action Notes

8. PARC. EXT/JOUR ? PLUS TARD

Dissolve	Duration 00:24
----------	-------------------

Scene	Duration	Panel	Duration
111	02:18	1	02:18

Scene	Duration	Panel	Duration
112	07:18	1	00:11

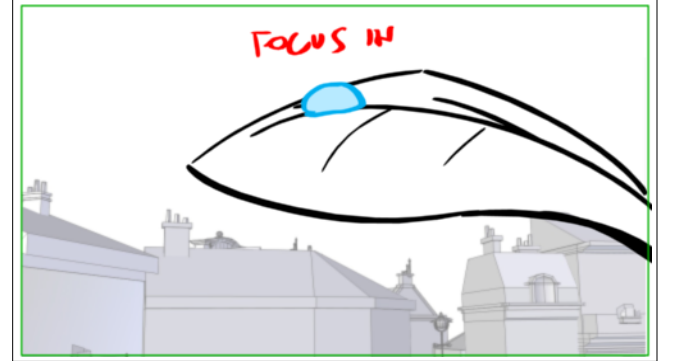
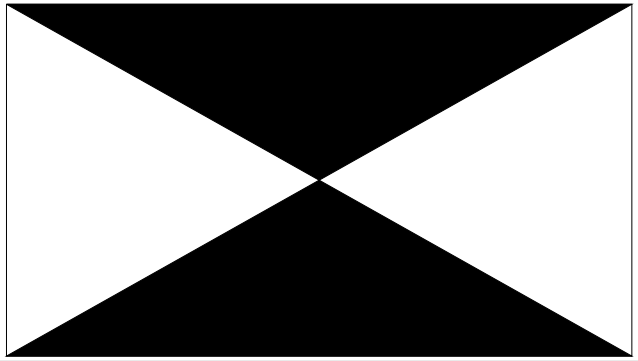

Action Notes
8. PARC. EXT/JOUR ? PLUS TARD

Scene	Duration	Panel	Duration
112	07:18	2	00:22

Scene	Duration	Panel	Duration
112	07:18	3	00:18

Scene	Duration	Panel	Duration
112	07:18	4	00:08

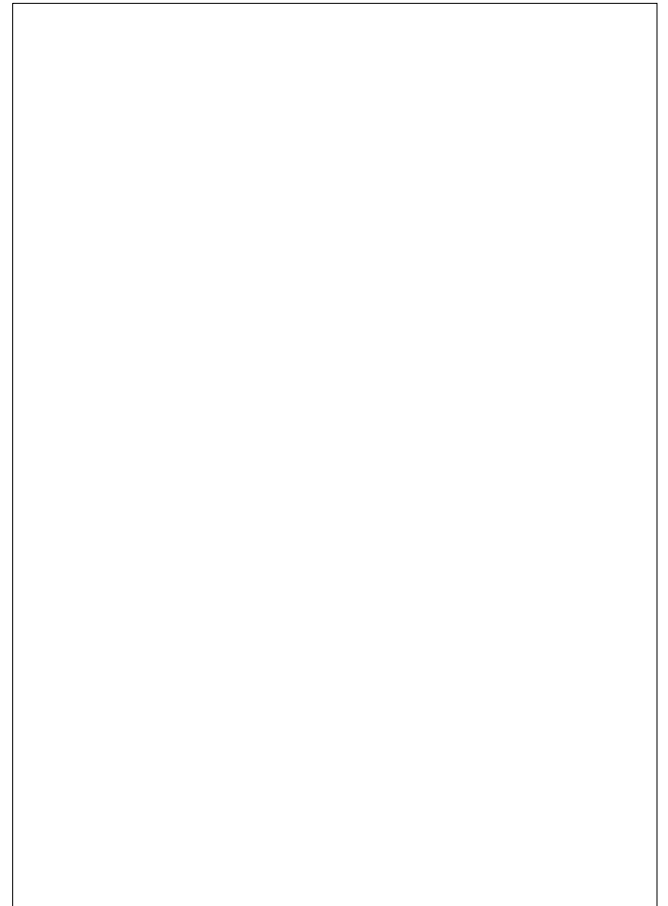
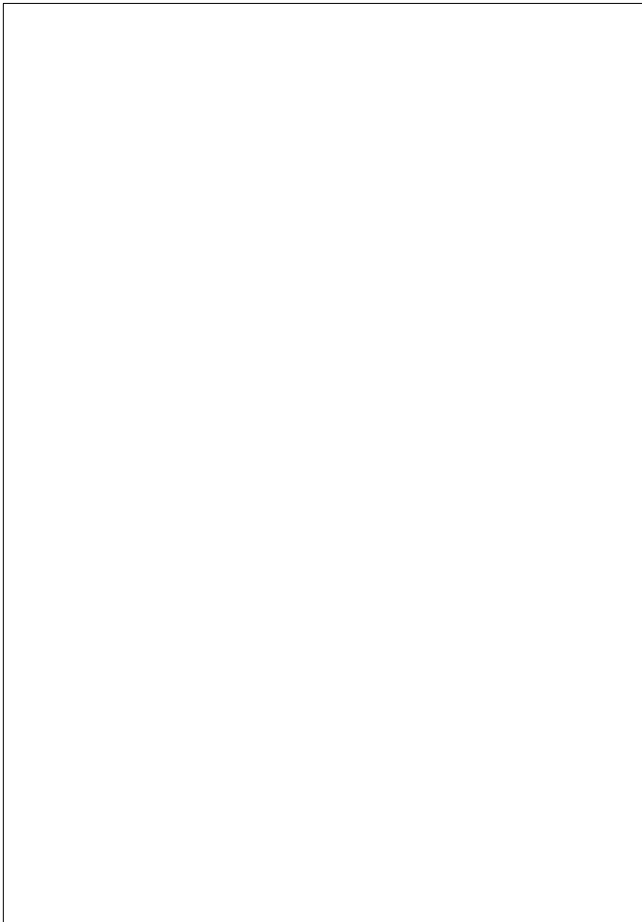
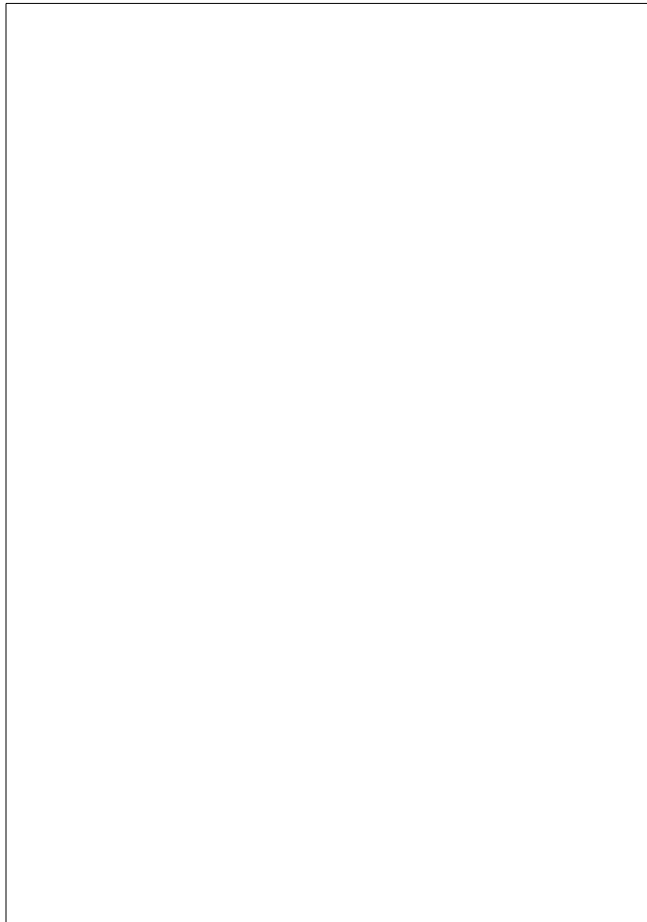
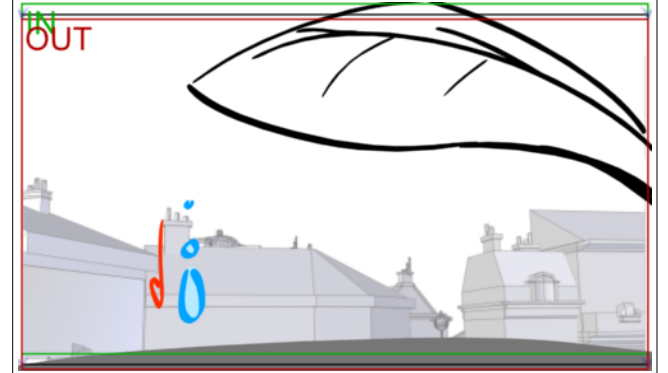
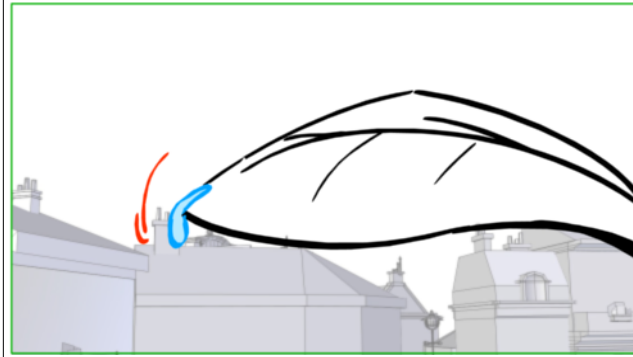
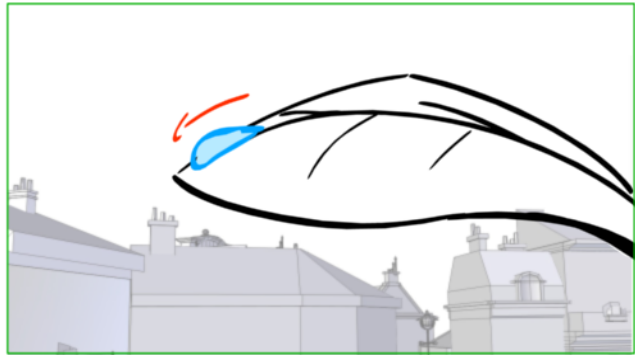

Scene	Duration	Panel	Duration
112	07:18	5	00:10

Scene	Duration	Panel	Duration
112	07:18	6	02:12

Scene	Duration	Panel	Duration
112	07:18	7	02:12

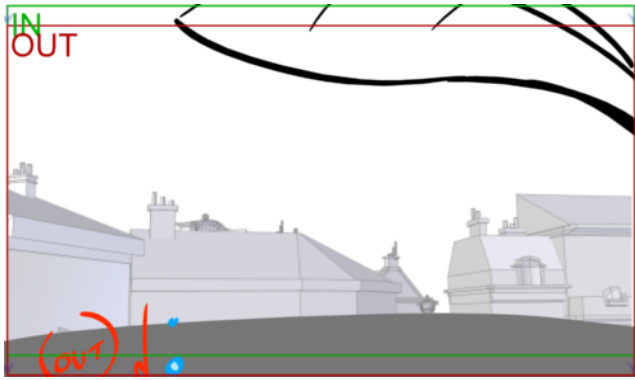

Dialogue

64. PRISCILLA, VALERIANO, PIERROT (mains en porte-voix, en chœur)
CALIMERO ? CALIMEROOOOO ?

Dialogue

64. PRISCILLA, VALERIANO, PIERROT (mains en porte-voix, en chœur)
CALIMERO ? CALIMEROOOOO ?

Scene	Duration	Panel	Duration
113	01:14	1	00:14



Scene	Duration	Panel	Duration
113	01:14	2	01:00



Scene	Duration	Panel	Duration
114	02:18	1	01:00

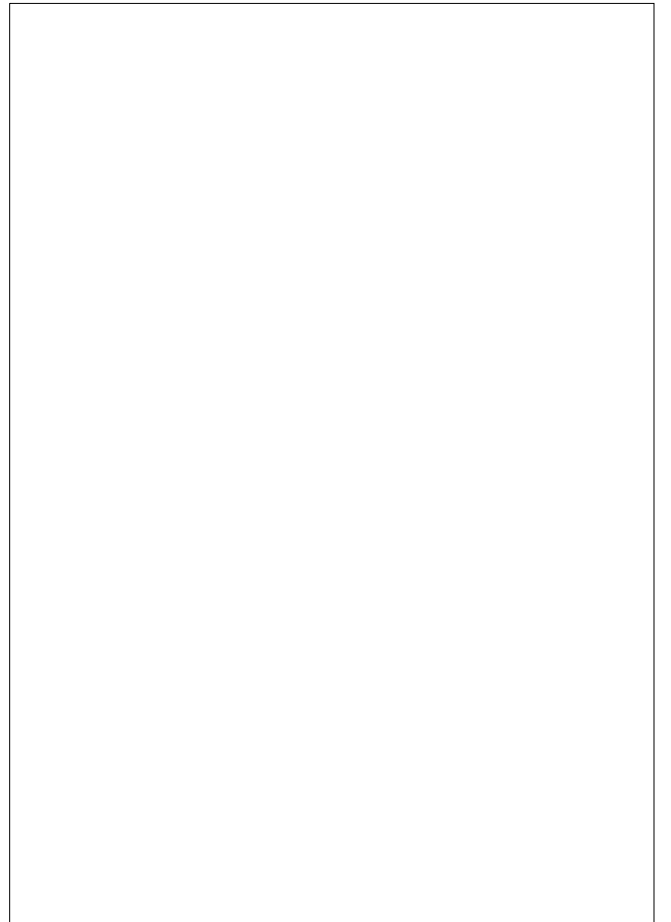
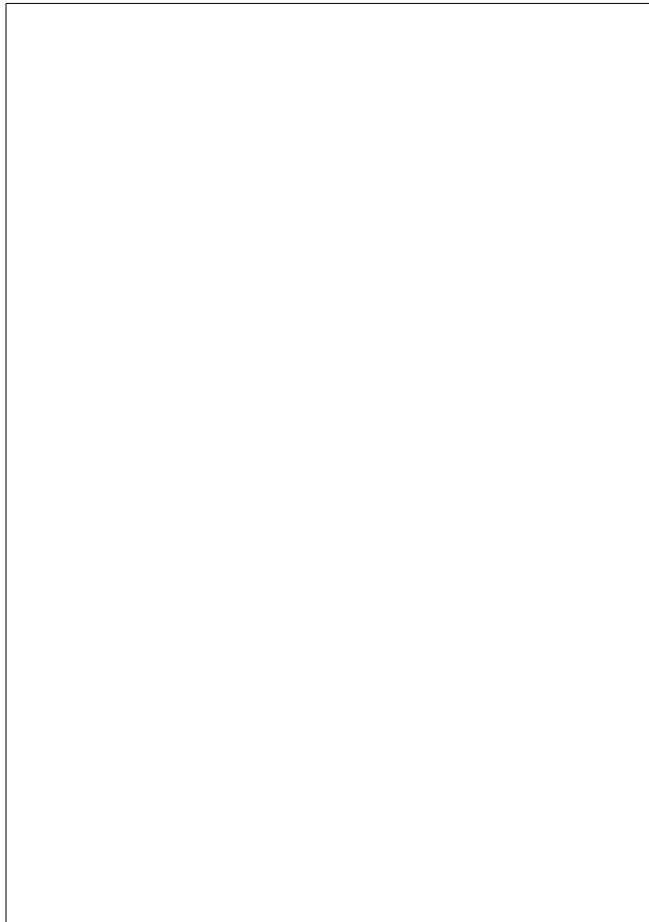

Scene	Duration	Panel	Duration
114	02:18	2	01:00



Scene	Duration	Panel	Duration
114	02:18	3	00:18

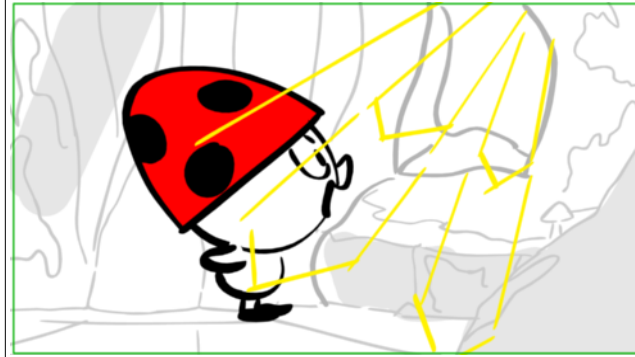

Dialogue

67. PRISCILLA (OFF, la voix se rapproche)
Caliméro ?

Scene	Duration	Panel	Duration
115	07:02	1	00:11

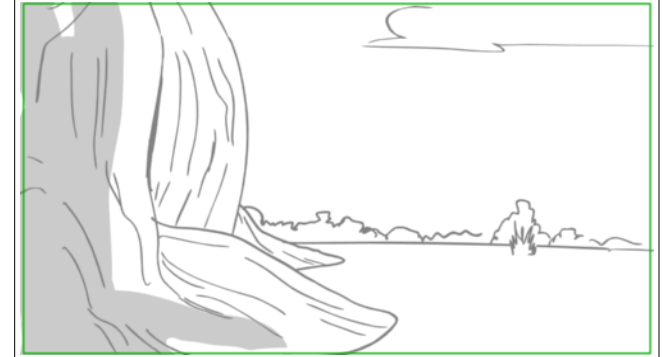

Dialogue

67. PRISCILLA
Tu es là Caliméro ?!

Scene	Duration	Panel	Duration
115	07:02	2	01:00



Dialogue

67. PRISCILLA
Tu es là Caliméro ?!

Scene	Duration	Panel	Duration
115	07:02	3	01:00



Dialogue

68. CALIMERO (OFF, voix blanche)
Désolé Priscilla, mais je ne peux pas
sortir du cerisier

Scene	Duration	Panel	Duration
115	07:02	4	01:00

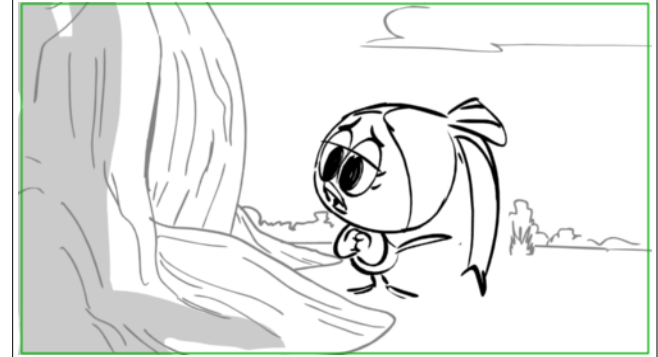

Dialogue

69. PRISCILLA (apaisante)
C'est à cause de ta coquille ?

Scene	Duration	Panel	Duration
115	07:02	5	01:00

Scene	Duration	Panel	Duration
115	07:02	6	02:16

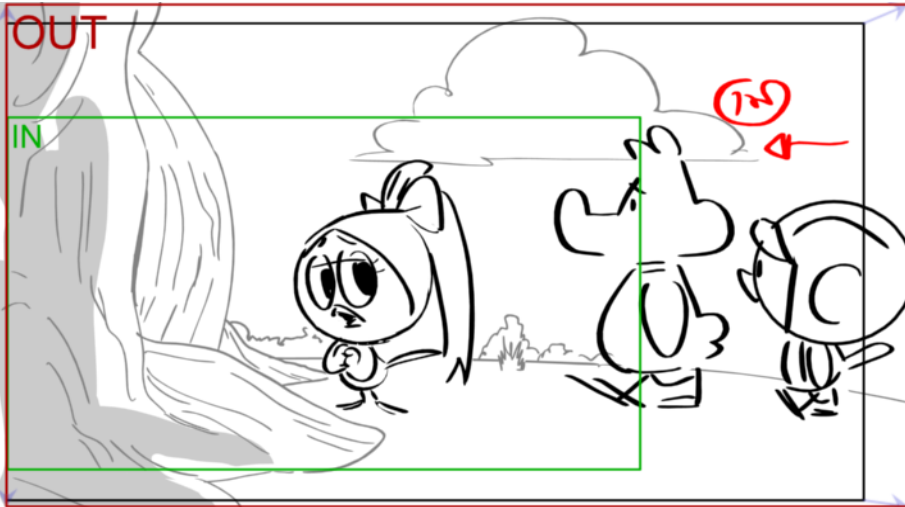

Dialogue
 69. PRISCILLA (apaisante)
 Valériano et Pierrot m'ont tout raconté?

Dialogue
 69. PRISCILLA (apaisante)
 Valériano et Pierrot m'ont tout raconté?

Scene	Duration	Panel	Duration
116	04:03	1	01:00

**Dialogue**

70. CALIMERO (off, tentant une explication)

Oui,

Scene	Duration	Panel	Duration
116	04:03	2	01:18

**Dialogue**

70. CALIMERO (off, tentant une explication)

elle est toute rouge, rouge avec des pois noirs.

Scene	Duration	Panel	Duration
116	04:03	3	01:10

**Dialogue**

71. PRISCILLA (s'emportant)

Mais Caliméro, que ta coquille soit blanche, verte ou n'importe comment,



Scene	Duration	Panel	Duration
117	04:08	1	00:15

Scene	Duration	Panel	Duration
117	04:08	2	00:08

Scene	Duration	Panel	Duration
117	04:08	3	00:12

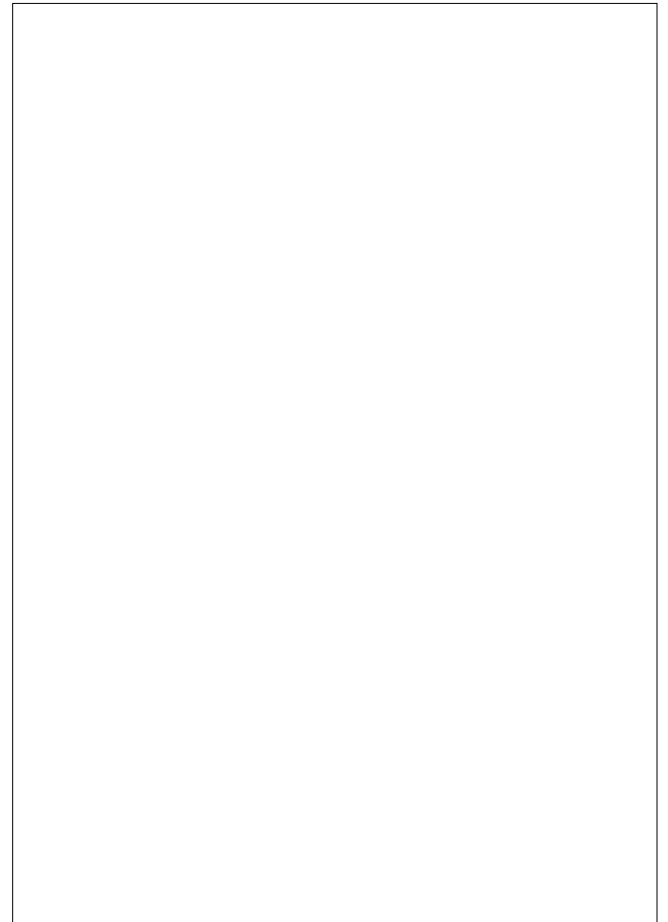
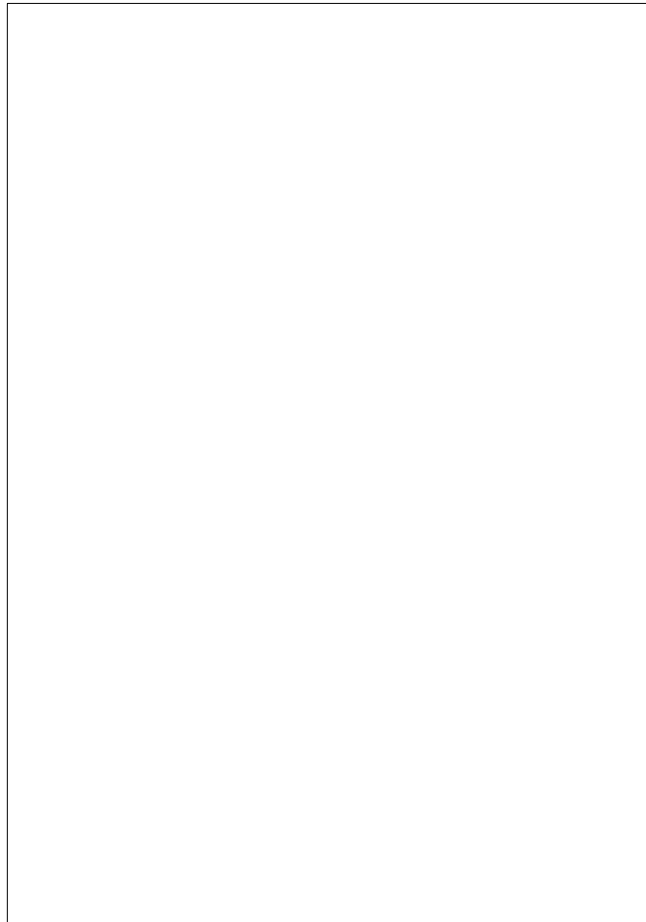
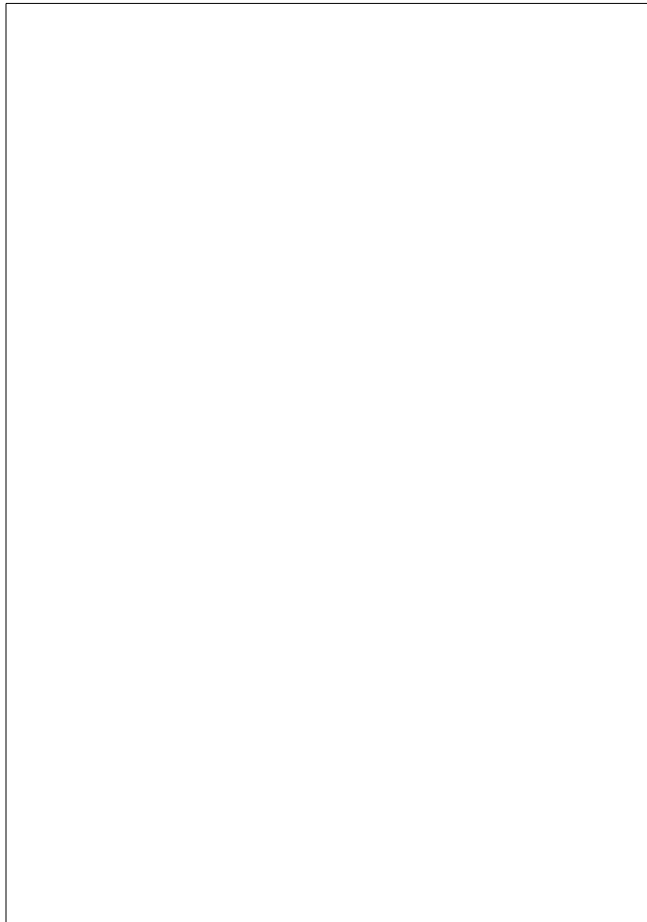
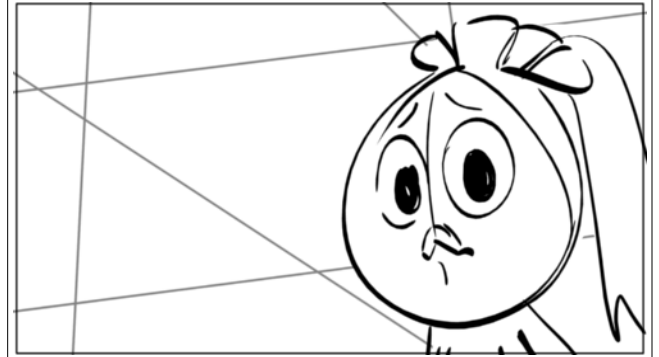
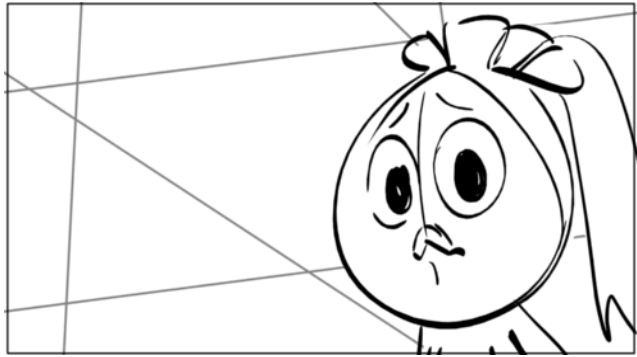



Scene	Duration	Panel	Duration
117	04:08	4	00:24

Scene	Duration	Panel	Duration
117	04:08	5	00:11

Scene	Duration	Panel	Duration
117	04:08	6	00:10

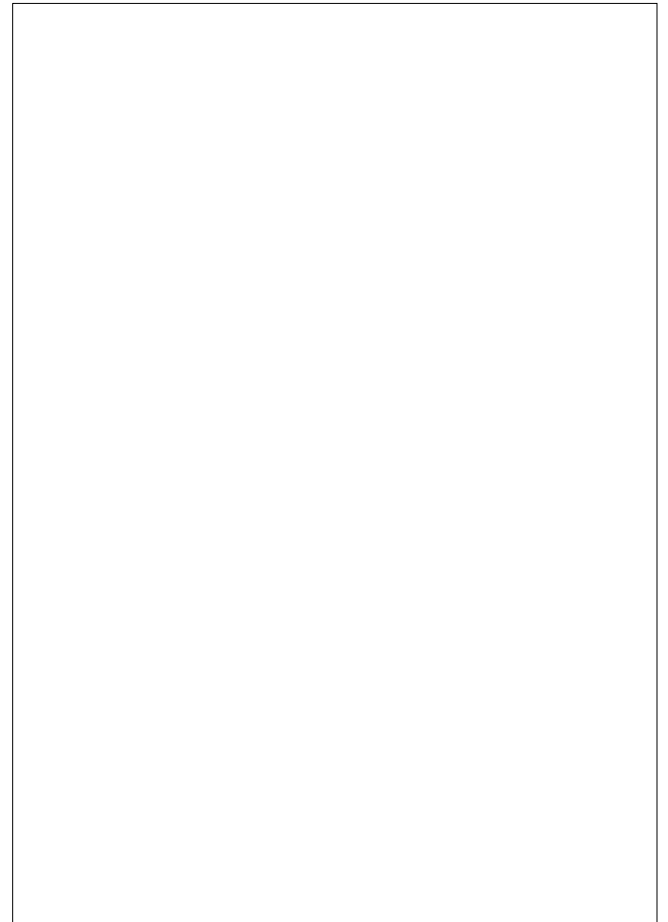
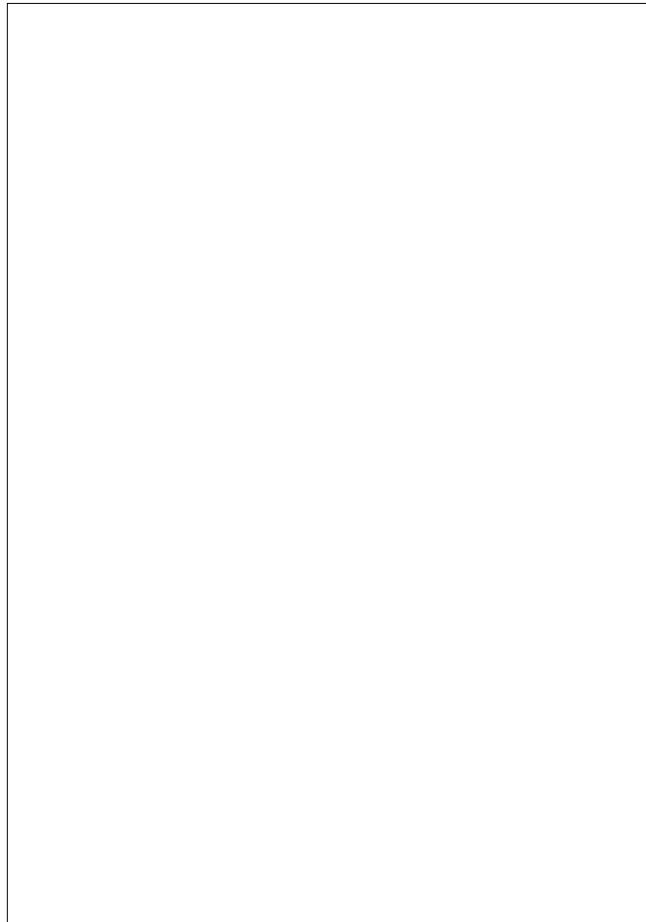
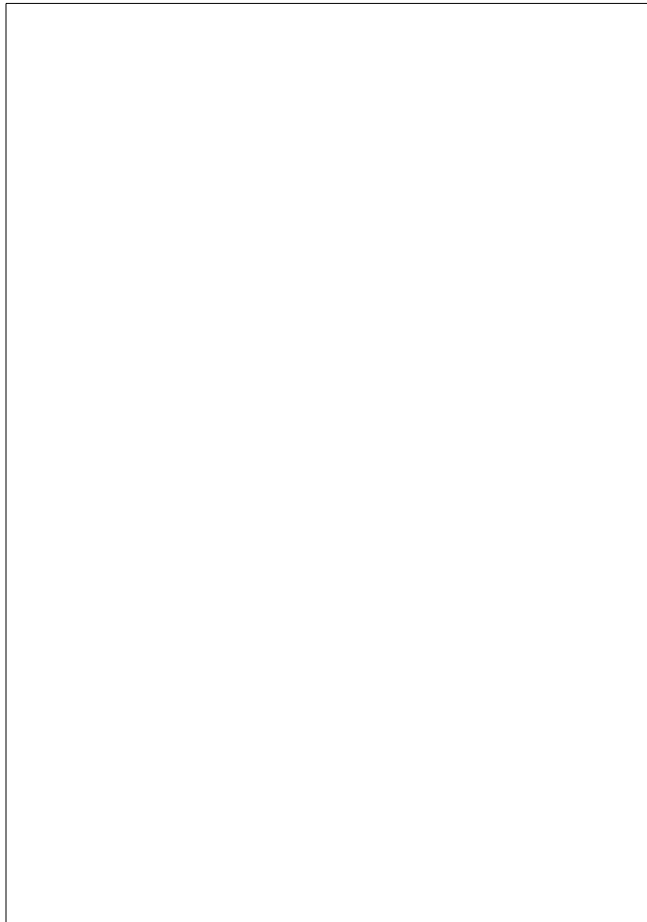
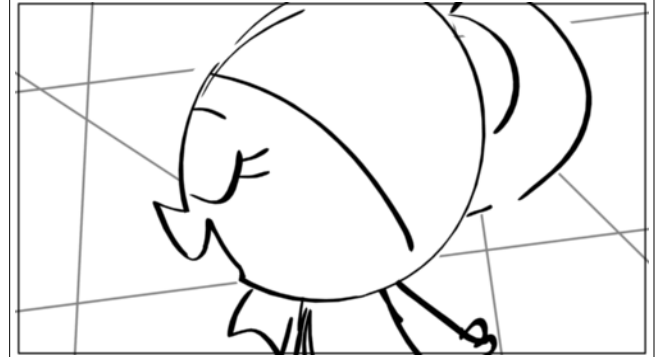
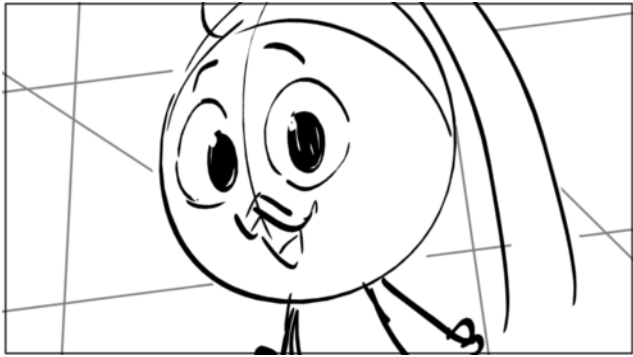

Scene	Duration	Panel	Duration
117	04:08	7	01:03

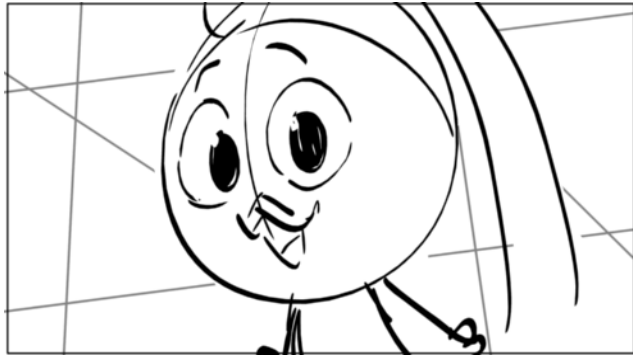

Scene	Duration	Panel	Duration
118	02:17	1	00:11



Dialogue

71. PRISCILLA (s'emportant)
 moi je t'aime comme tu es et c'est
 tout !

Scene	Duration	Panel	Duration
118	02:17	2	00:13

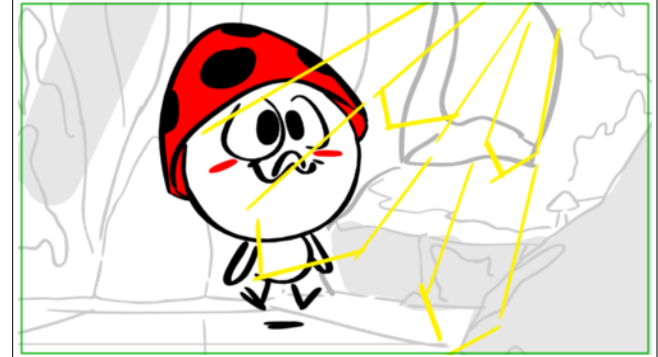

Dialogue

71. PRISCILLA (s'emportant)
 moi je t'aime comme tu es et c'est
 tout !

Scene	Duration	Panel	Duration
118	02:17	3	01:18



Dialogue
 72. CALIMERO (timidement, en direction de Priscilla)
 C'est bien vrai Priscilla ?

Scene	Duration	Panel	Duration
119	06:23	1	01:00



Scene	Duration	Panel	Duration
119	06:23	2	00:13



Scene	Duration	Panel	Duration
119	06:23	3	00:11



Scene	Duration	Panel	Duration
119	06:23	4	02:14



Dialogue

72. CALIMERO (timidement, en direction de Priscilla)
 Tu ne trouves pas ma coquille ridicule ?

Scene	Duration	Panel	Duration
119	06:23	5	01:14



Dialogue

73. PRISCILLA (dynamique)
 Mais non, pas du tout !

Scene	Duration	Panel	Duration
119	06:23	6	00:21

Scene	Duration	Panel	Duration
120	05:12	1	00:12

NO PANEL

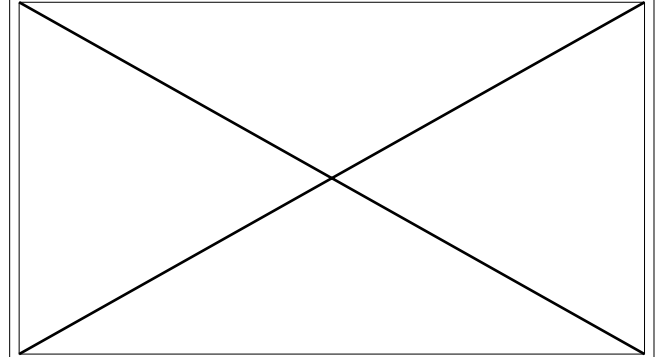
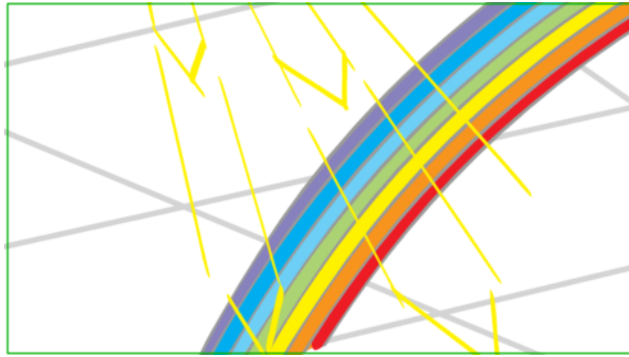

Dialogue
 73. PRISCILLA (dynamique)
 Regarde, c'est comme cet arc-en-ciel,

Dialogue
 73. PRISCILLA (dynamique)
 il est tout coloré, c'est très joli !

Scene	Duration	Panel	Duration
120	05:12	2	04:00

Scene	Duration	Panel	Duration
120	05:12	3	01:00

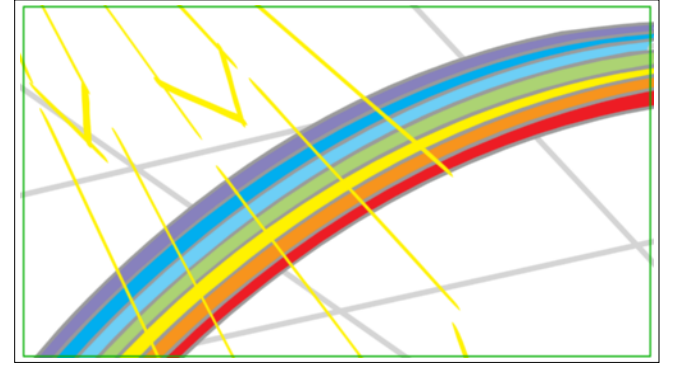
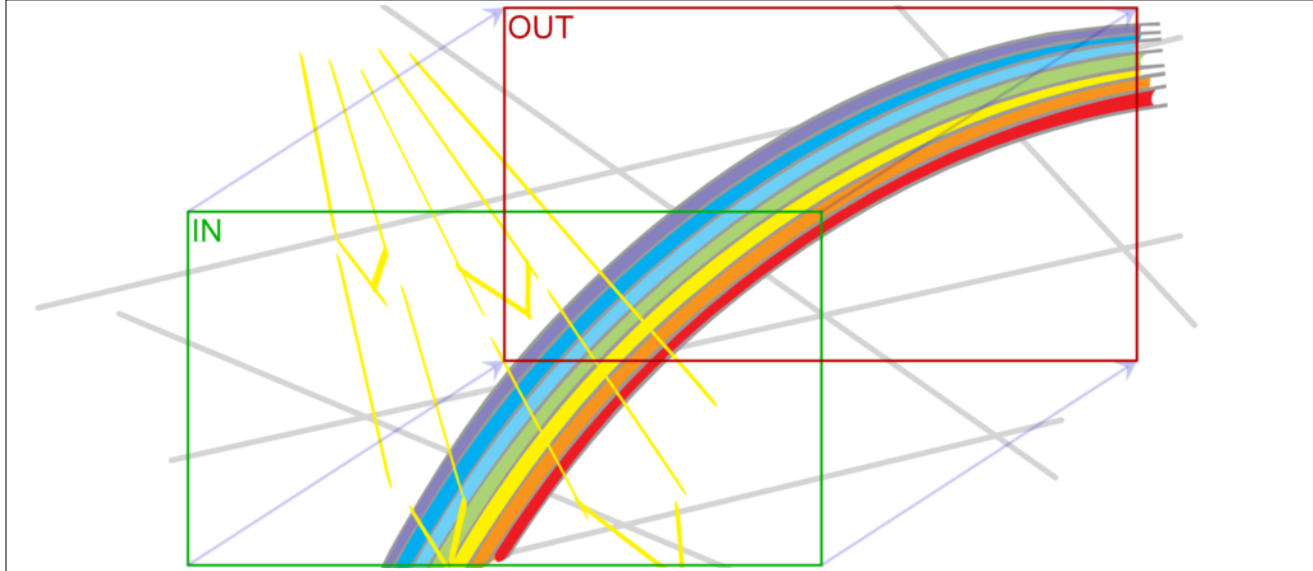

Dialogue

73. PRISCILLA (dynamique)
il est tout coloré, c'est très joli !

Scene	Duration	Panel	Duration
121	04:16	1	00:20

Scene	Duration	Panel	Duration
121	04:16	2	03:21

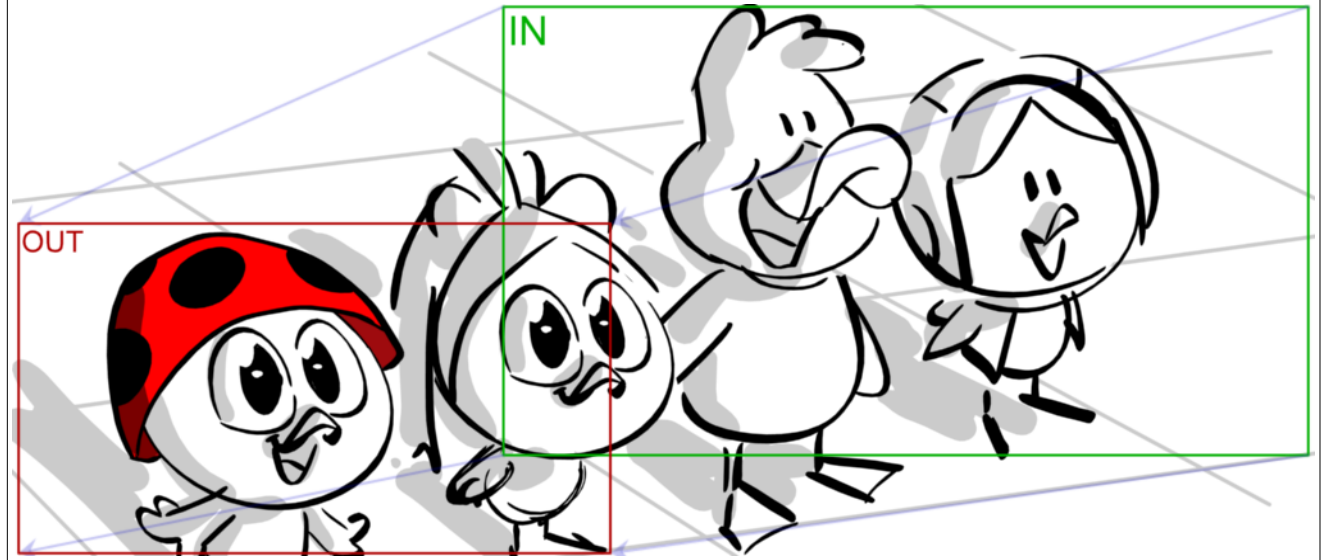
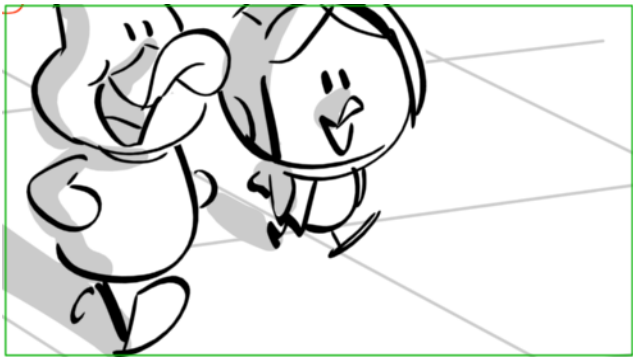

Dialogue
 PICK UP CALIMERO
 Waaaa!

Dialogue
 PICK UP CALIMERO
 Waaaa!

Scene	Duration	Panel	Duration
122	06:00	1	02:16



Dialogue

74. PIERROT (songeur, dans l'interrogation)
 C'est quand même dingue toutes ces couleurs !

75. VALERIANO (emphatique)
 Moi je trouve que c'est super mega beau !

Scene	Duration	Panel	Duration
122	06:00	2	01:22

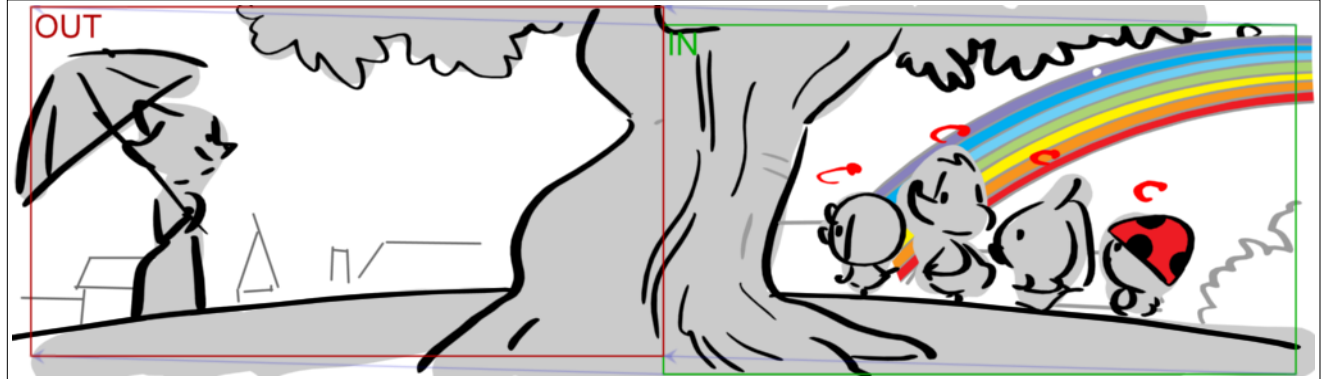

Dialogue

76. CAMILLE (off, puis in, douce)
 Et vous savez d'où elles viennent toutes ces couleurs, les enfants ?

Scene	Duration	Panel	Duration
122	06:00	3	00:13

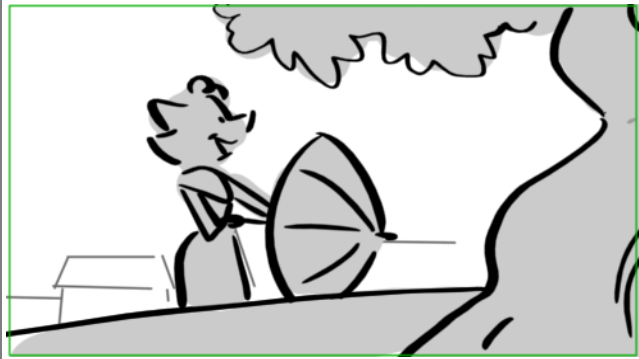

Dialogue

76. CAMILLE (off, puis in, douce)
Et vous savez d'où elles viennent
toutes ces couleurs, les enfants ?

Scene	Duration	Panel	Duration
122	06:00	4	00:12



Dialogue

76. CAMILLE (off, puis in, douce)
Et vous savez d'où elles viennent
toutes ces couleurs, les enfants ?

Scene	Duration	Panel	Duration
122	06:00	5	00:12

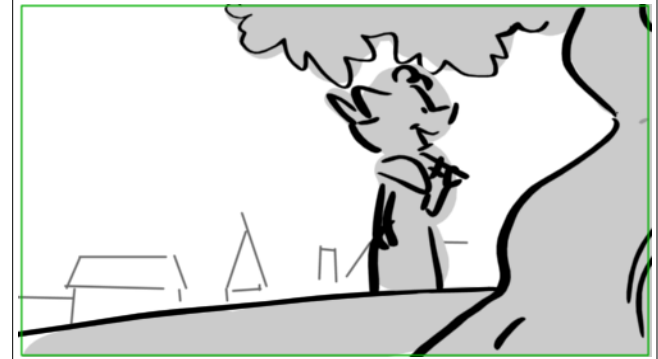

Dialogue

76. CAMILLE (off, puis in, douce)
Et vous savez d'où elles viennent
toutes ces couleurs, les enfants ?

Scene	Duration	Panel	Duration
123	03:07	1	00:10

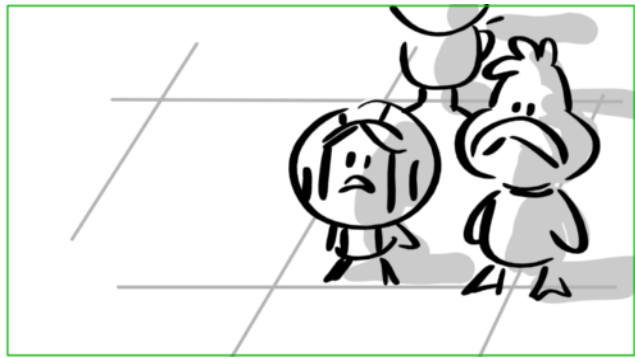

Scene	Duration	Panel	Duration
123	03:07	2	00:11

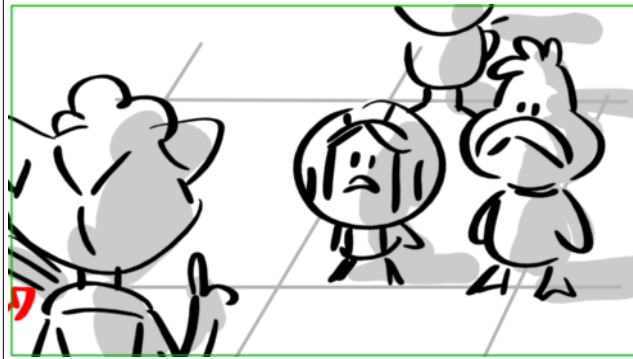

Dialogue

76. CAMILLE (off, puis in, douce)
Elles viennent du Soleil?

Scene	Duration	Panel	Duration
123	03:07	3	01:03

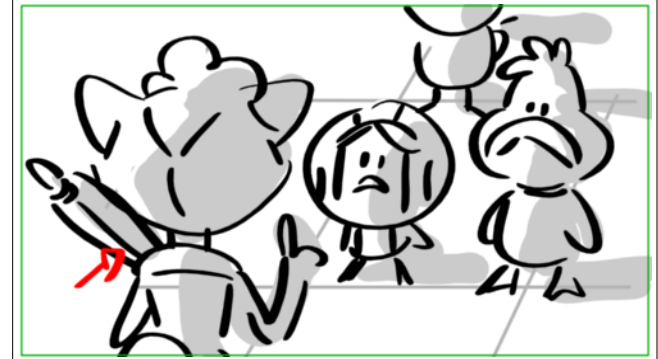

Dialogue

76. CAMILLE (off, puis in, douce)
Elles viennent du Soleil?

Scene	Duration	Panel	Duration
123	03:07	4	00:08

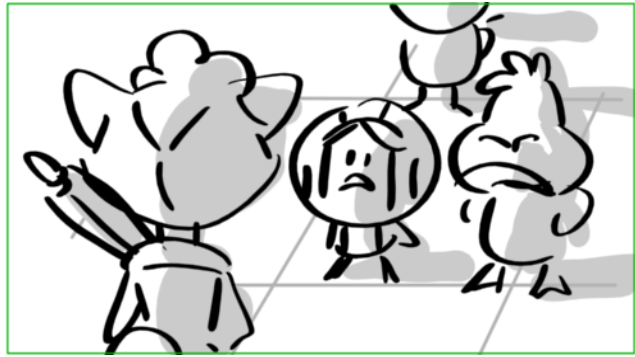

Scene	Duration	Panel	Duration
123	03:07	5	01:00

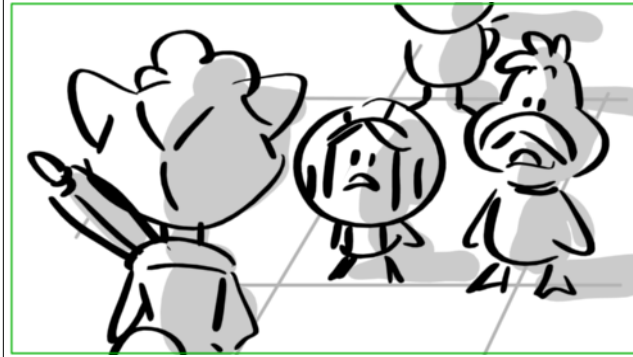

Dialogue
 77. PIERROT (surpris)
 Du soleil ?

Scene	Duration	Panel	Duration
124	05:22	1	00:10



Dialogue
 78. CAMILLE (un peu mystérieuse)
 Mais oui Pierrot !

Scene	Duration	Panel	Duration
124	05:22	2	00:20

Scene	Duration	Panel	Duration
124	05:22	3	00:21

NO PANEL

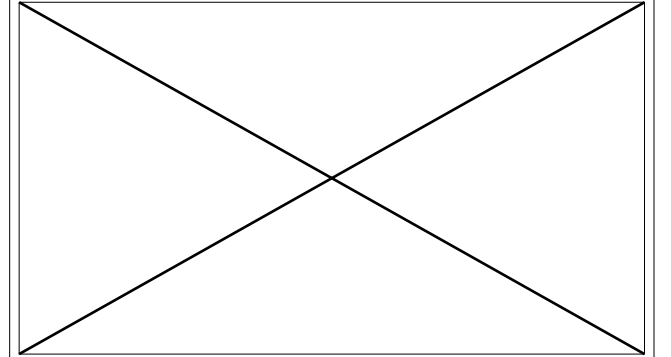

Dialogue
 78. CAMILLE (un peu mystérieuse)
 Mais oui Pierrot !

Dialogue
 78. CAMILLE (un peu mystérieuse)
 Mais oui Pierrot !

Scene	Duration	Panel	Duration
124	05:22	4	02:11

Scene	Duration	Panel	Duration
124	05:22	5	01:10

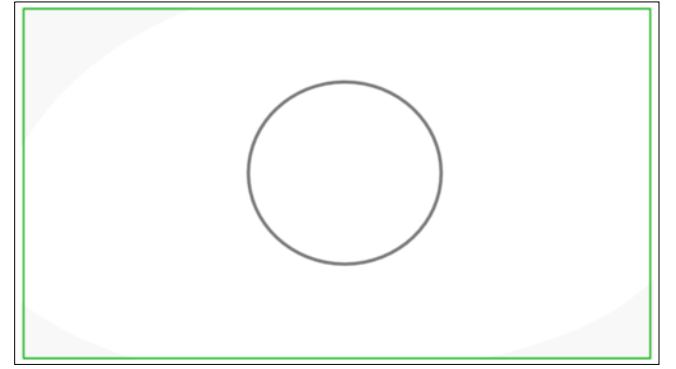
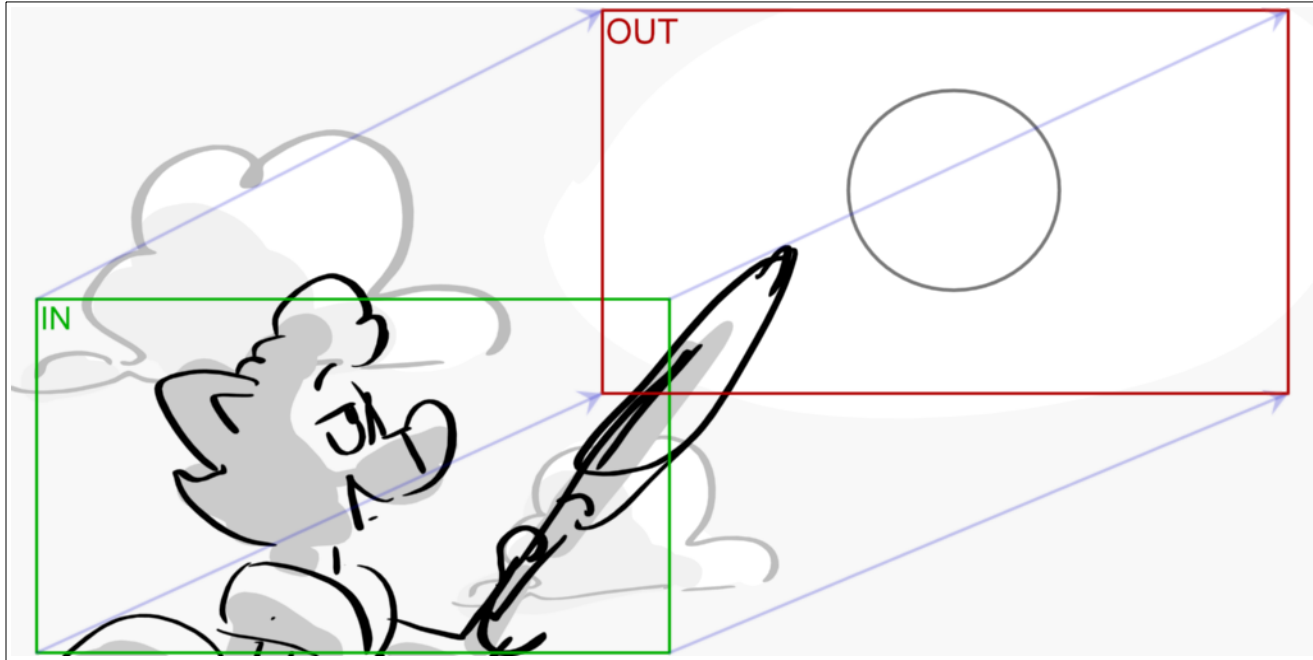

Dialogue
 78. CAMILLE (un peu mystérieuse)
 Dans la lumière du soleil, il y a en fait plein de couleurs différentes !

Dialogue
 78. CAMILLE (un peu mystérieuse)
 Dans la lumière du soleil, il y a en fait plein de couleurs différentes !



Dissolve	Duration 00:24
----------	-------------------

Scene 125	Duration 20:03	Panel 1	Duration 02:13
--------------	-------------------	------------	-------------------

NO PANEL

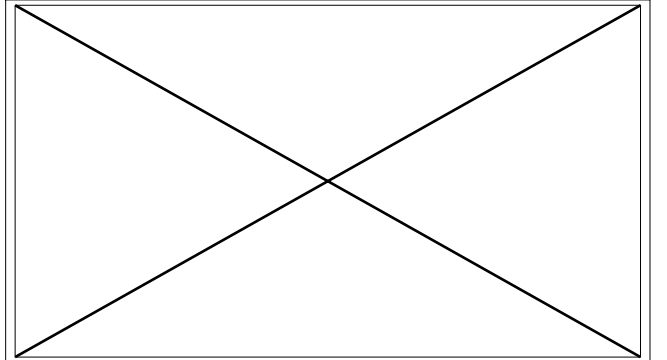
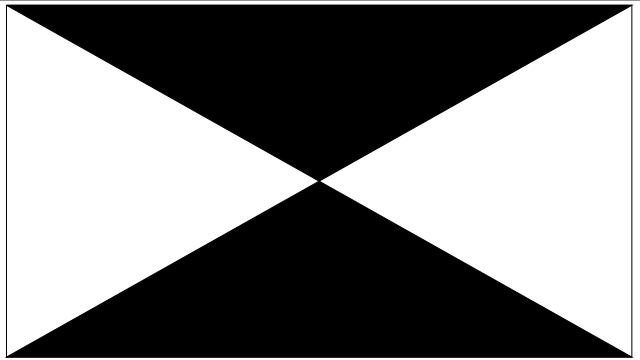

Dialogue
79. CAMILLE (voice over, elle conte)
Quand il fait beau, nous ne percevons
que de la lumière blanche?

Action Notes
9. SEQUENCE 2D

Scene	Duration	Panel	Duration
125	20:03	2	01:09

Scene	Duration	Panel	Duration
125	20:03	3	03:16

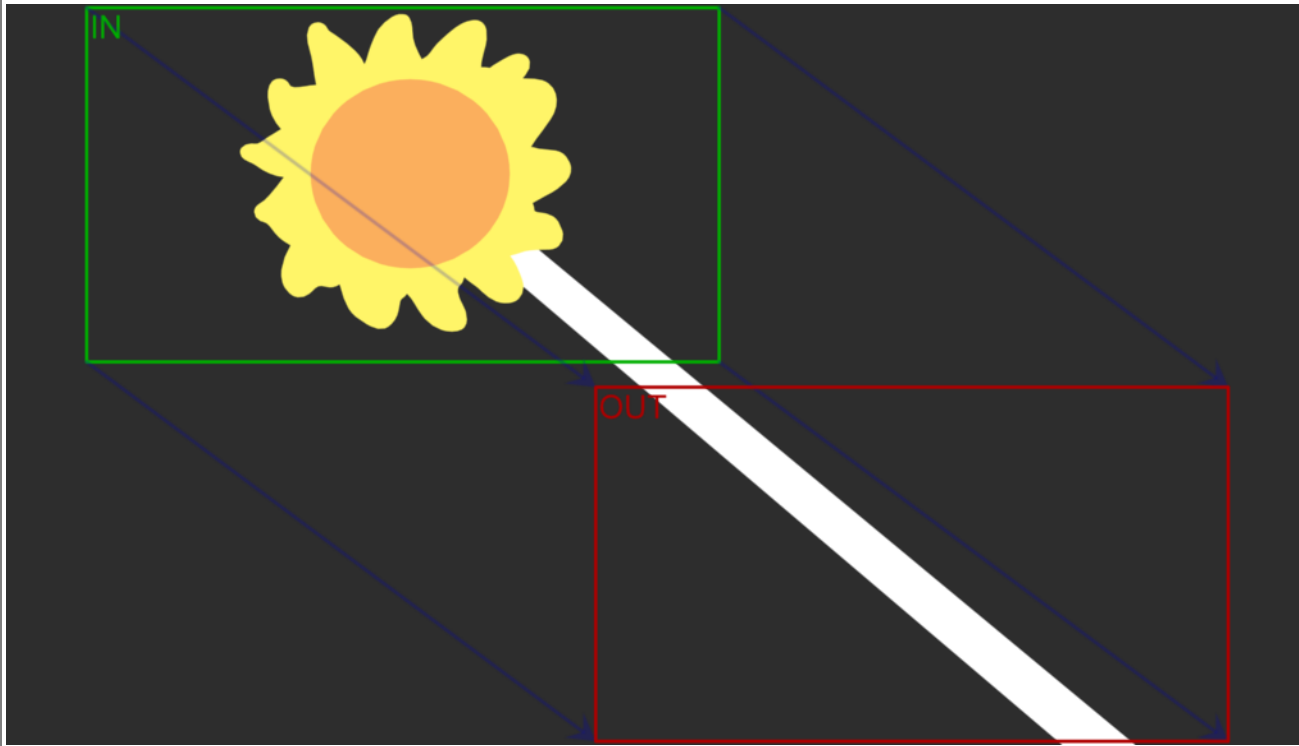

Dialogue
 79. CAMILLE (voice over, elle conte)
 Quand il fait beau, nous ne percevons que de la lumière blanche?

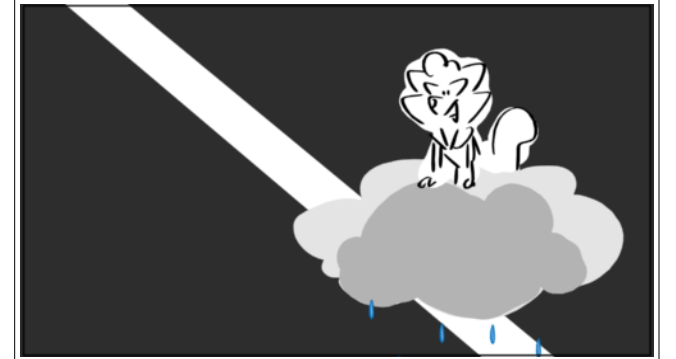

Dialogue
 80. CAMILLE (voice over, elle conte)
 Mais après la pluie?? quand le soleil
 brille à nouveau,

Scene	Duration	Panel	Duration
125	20:03	4	06:08

NO PANEL

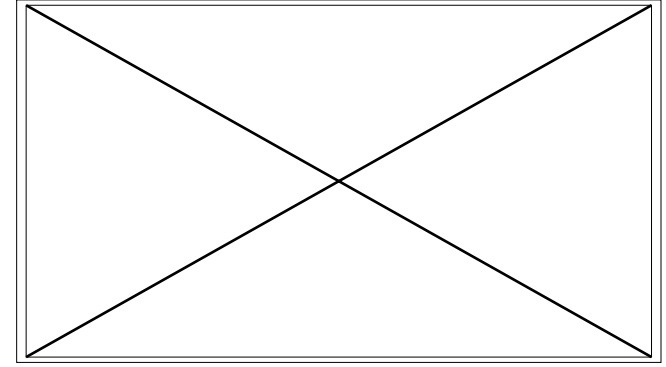
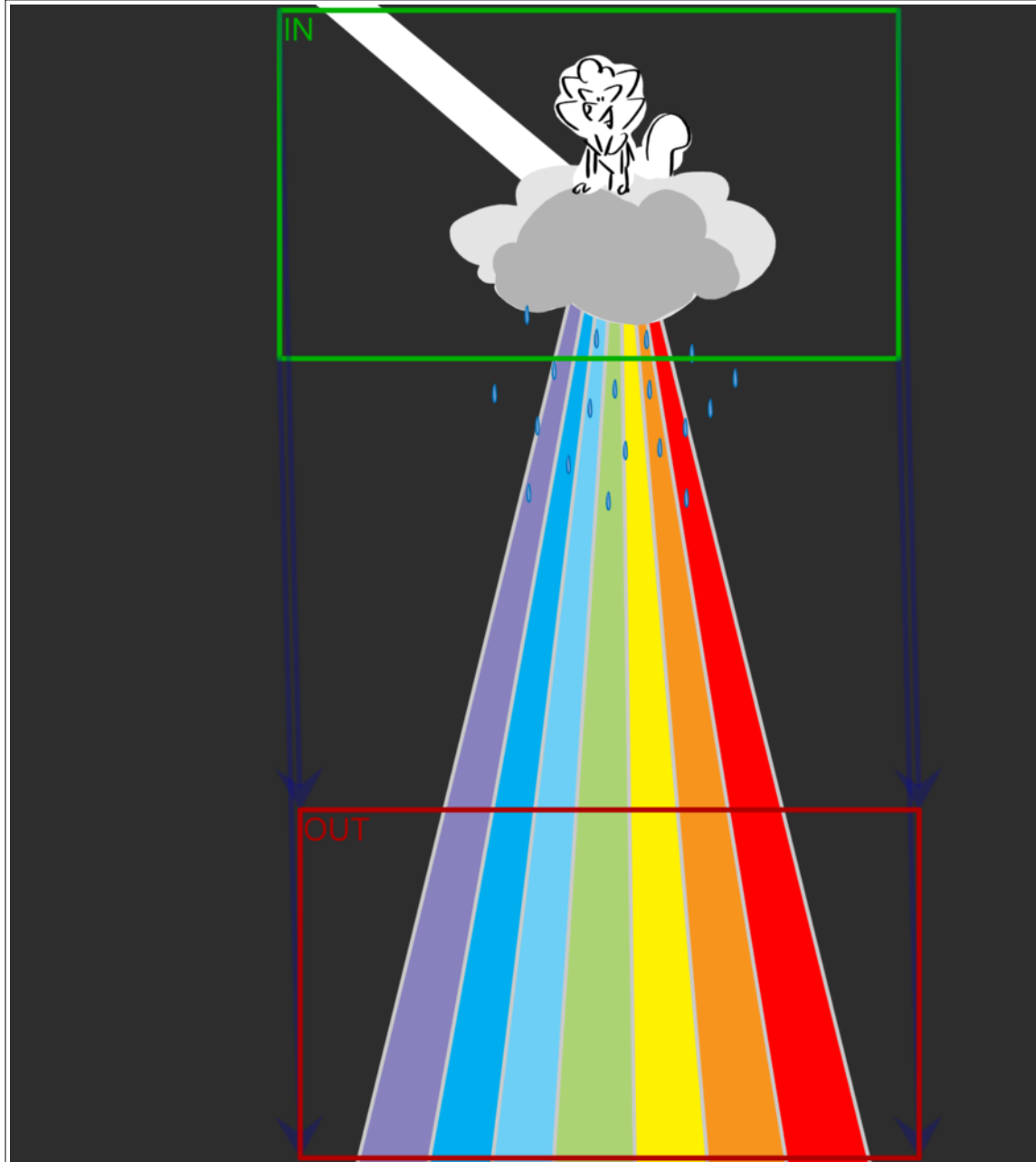

Dialogue

81. CAMILLE (voice over, elle conte)
nous pouvons parfois les voir se
séparer. Ce sont les couleurs de l'arc
en ciel ! Vous les voyez ?

Scene	Duration	Panel	Duration
125	20:03	5	00:23

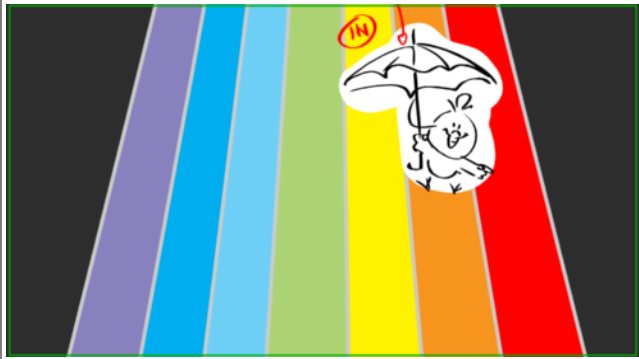

Dialogue
 82. PRISCILLA (enthousiaste, pointant le bras)
 Oui, il y a du rouge !

Scene	Duration	Panel	Duration
125	20:03	6	00:23



Dialogue
 82. PRISCILLA (enthousiaste, pointant le bras)
 Oui, il y a du rouge !

Scene	Duration	Panel	Duration
125	20:03	7	00:05

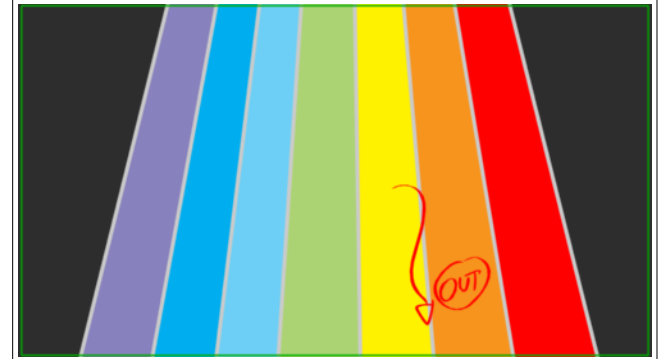

Dialogue
 82. PRISCILLA (enthousiaste, pointant le bras)
 Oui, il y a du rouge !

Scene	Duration	Panel	Duration
125	20:03	8	00:17

Scene	Duration	Panel	Duration
125	20:03	9	00:21

Scene	Duration	Panel	Duration
125	20:03	10	00:05

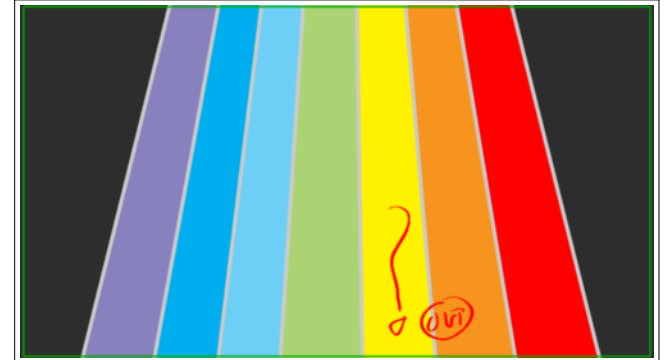
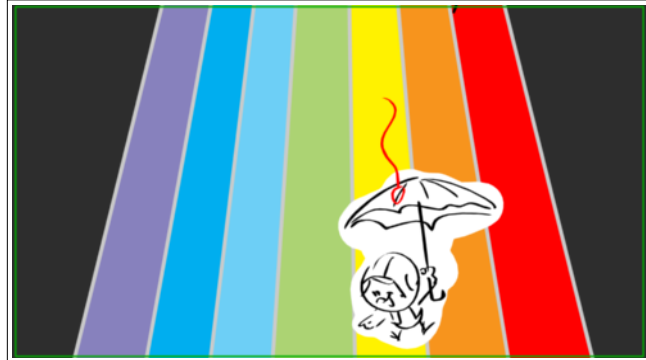

Dialogue
 83. VALERIANO (enthousiaste)
 Et là, je vois du vert !

Dialogue
 83. VALERIANO (enthousiaste)
 Et là, je vois du vert !

Dialogue
 83. VALERIANO (enthousiaste)
 Et là, je vois du vert !

Scene	Duration	Panel	Duration
125	20:03	11	00:18

Scene	Duration	Panel	Duration
125	20:03	12	00:24

Scene	Duration	Panel	Duration
125	20:03	13	00:21

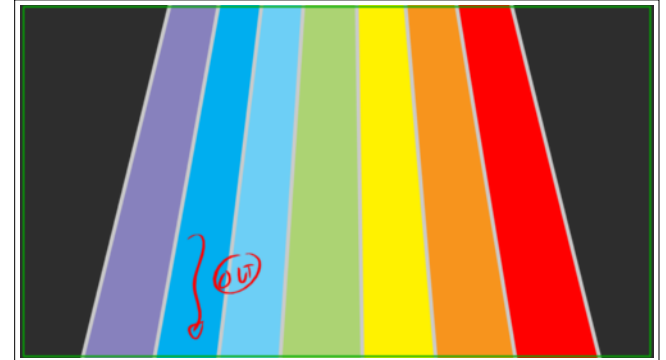
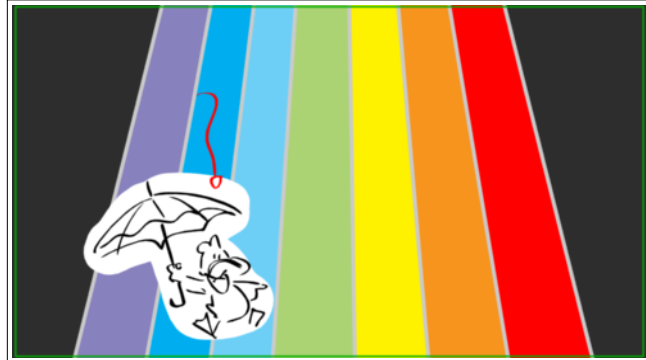
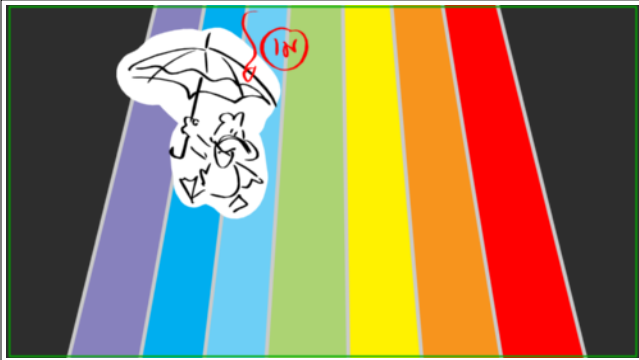

Dialogue
 84. PIERROT (enthousiaste)
 Et du bleu!

Dialogue
 84. PIERROT (enthousiaste)
 Et du bleu!

Dialogue
 84. PIERROT (enthousiaste)
 Et du bleu!

Scene	Duration	Panel	Duration
126	04:12	1	04:12

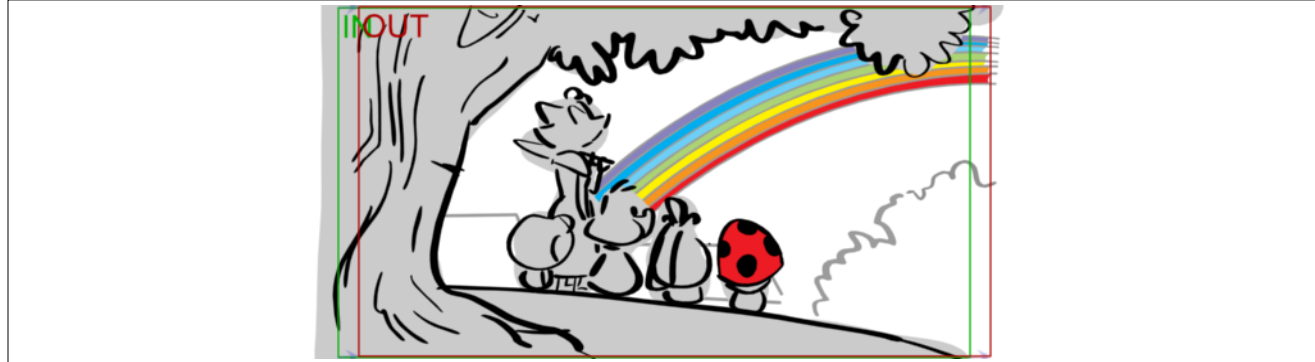

Dialogue

PICK UP CALIMERO

Ca alors! ca veut dire que le blanc c'est toutes les couleurs à la fois?

Scene	Duration	Panel	Duration
127	03:07	1	01:00



Dialogue

88. MODIF CAMILLE

Oui?

Scene	Duration	Panel	Duration
127	03:07	2	01:00

Scene	Duration	Panel	Duration
127	03:07	3	00:07

Scene	Duration	Panel	Duration
127	03:07	4	01:00



Dialogue
 88. MODIF CAMILLE
 on peut dire ça comme ça...

Dialogue
 86. CAMILLE (surprise)MODIF
 Oh !

Scene	Duration	Panel	Duration
128	06:20	1	02:15

Scene	Duration	Panel	Duration
128	06:20	2	01:00



Dialogue

86. CAMILLE (surprise)MODIF
Très jolie ta coquille Calimero!

Dialogue

86. CAMILLE (surprise)MODIF
Très jolie ta coquille Calimero!

Scene	Duration	Panel	Duration
128	06:20	3	00:05

Scene	Duration	Panel	Duration
128	06:20	4	01:00

Scene	Duration	Panel	Duration
128	06:20	5	01:00

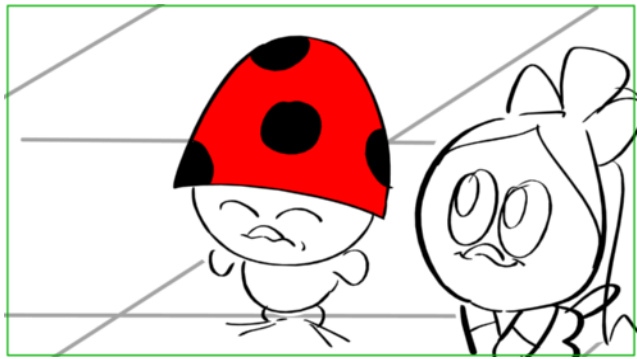

Dialogue

86. CAMILLE (surprise)MODIF
Très jolie ta coquille Calimero!

Dialogue

86. CAMILLE (surprise)MODIF
Très jolie ta coquille Calimero!

Dialogue

86. CAMILLE (surprise)MODIF
Très jolie ta coquille Calimero!

Scene	Duration	Panel	Duration
128	06:20	6	01:00



Scene	Duration	Panel	Duration
129	06:03	1	00:09



Dialogue

87. PIERROT (allègre)
C'est un arc en ciel qui lui est tombé sur la tête !

Scene	Duration	Panel	Duration
129	06:03	2	01:19

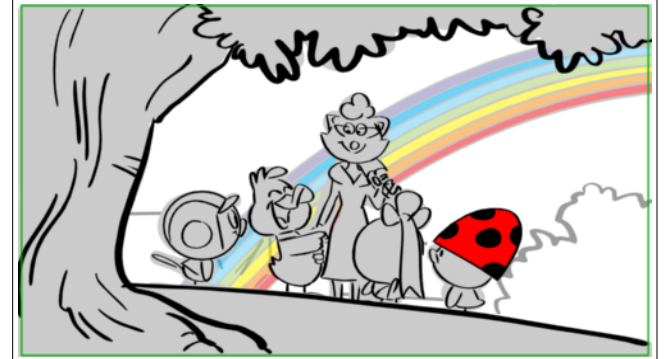

Dialogue

87. PIERROT (allègre)
C'est un arc en ciel qui lui est tombé sur la tête !

Scene	Duration	Panel	Duration
129	06:03	3	01:00

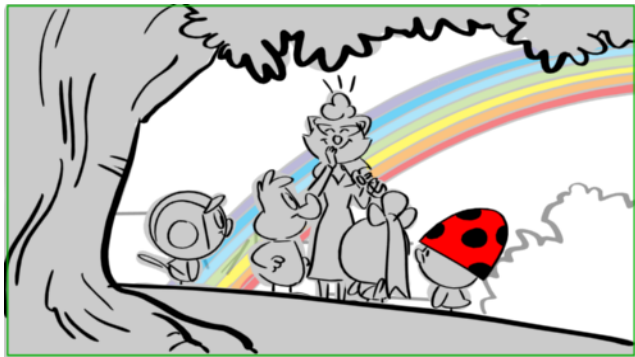

Dialogue
 PICK UP CAMILLE
 Petit rire

Scene	Duration	Panel	Duration
129	06:03	4	01:00



Dialogue
 89. CAMILLE (enjouée)
 Amusez vous bien les enfants !

Scene	Duration	Panel	Duration
129	06:03	5	01:00

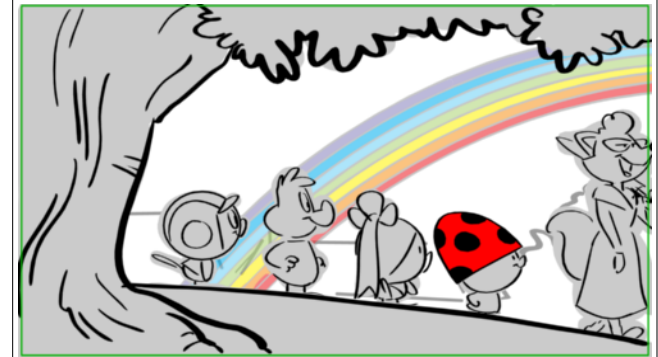

Dialogue
 89. CAMILLE (enjouée)
 Amusez vous bien les enfants !

Scene	Duration	Panel	Duration
129	06:03	6	01:00

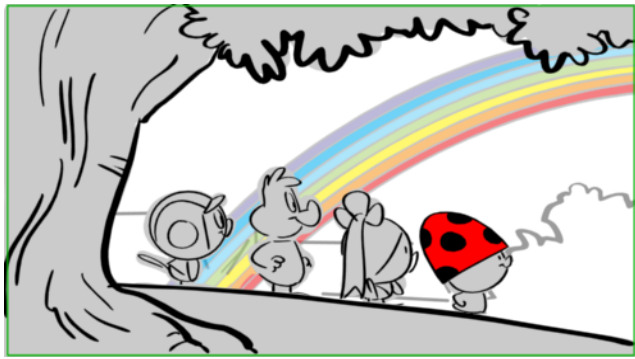

Scene	Duration	Panel	Duration
130	10:14	1	01:00



Scene	Duration	Panel	Duration
130	10:14	2	01:00



Dialogue

90. CALIMERO (son visage s'illumine)
 Vous savez quoi les amis?

Scene	Duration	Panel	Duration
130	10:14	3	03:02



Dialogue

90. CALIMERO (son visage s'illumine)
 Jje sais maintenant comment faire du blanc avec le Colorimoitout!

Scene	Duration	Panel	Duration
130	10:14	4	01:11



Dialogue

90. CALIMERO (son visage s'illumine)
 Jje sais maintenant comment faire du blanc avec le Colorimoitout!

Scene	Duration	Panel	Duration
130	10:14	5	01:02



Dialogue

90. CALIMERO (son visage s'illumine)
 Jje sais maintenant comment faire du blanc avec le Colorimoitout!

Scene	Duration	Panel	Duration
130	10:14	6	01:05



Dialogue

90. CALIMERO (son visage s'illumine)
 Jje sais maintenant comment faire du blanc avec le Colorimoitout!

Scene	Duration	Panel	Duration
130	10:14	7	01:19



Dialogue

90. CALIMERO (son visage s'illumine)
 Tous au moulin !

Scene	Duration	Panel	Duration
131	03:08	1	03:08



Dialogue

91. CALIMERO (montant la boîte à gélamines)
 Maintenant, il nous faut mettre toutes les couleurs ensemble?

Action Notes

11. MOULIN, ATELIER DE DO VINCI.
 INT/JOUR

Scene	Duration	Panel	Duration
132	02:16	1	00:23



Scene	Duration	Panel	Duration
132	02:16	2	00:19



Scene	Duration	Panel	Duration
132	02:16	3	00:24



Dialogue

92. PRISCILLA (exaltée)
Les couleurs de l'arc en ciel !

Dialogue

92. PRISCILLA (exaltée)
Les couleurs de l'arc en ciel !



Scene	Duration	Panel	Duration
133	06:09	1	01:00

Scene	Duration	Panel	Duration
133	06:09	2	01:00

Scene	Duration	Panel	Duration
133	06:09	3	01:03

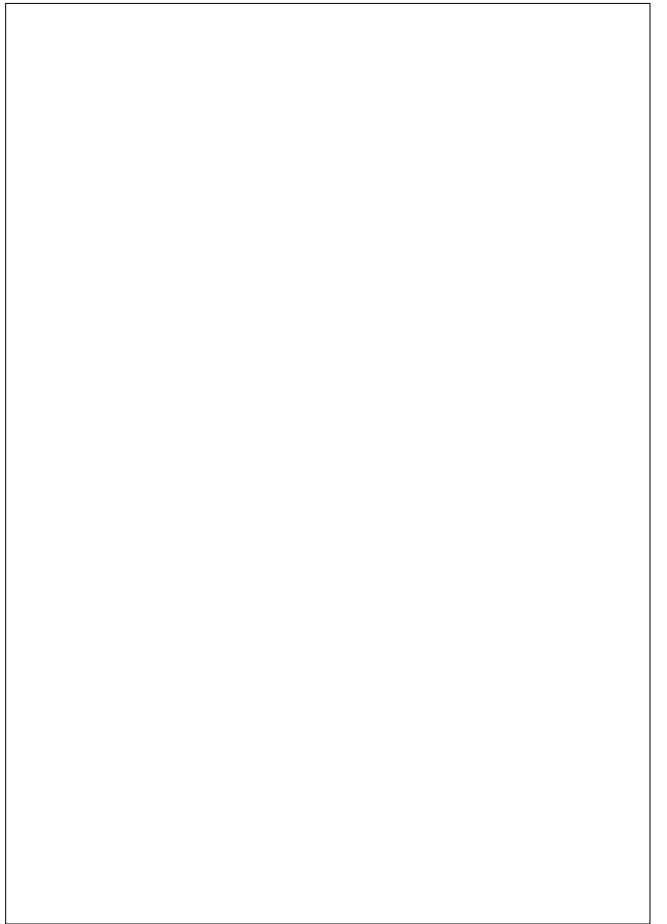
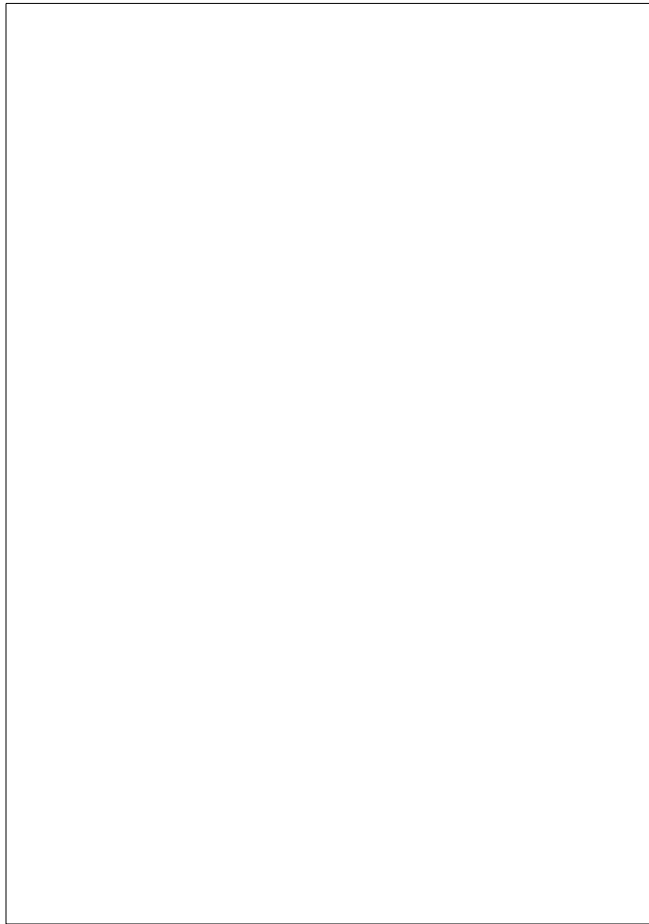
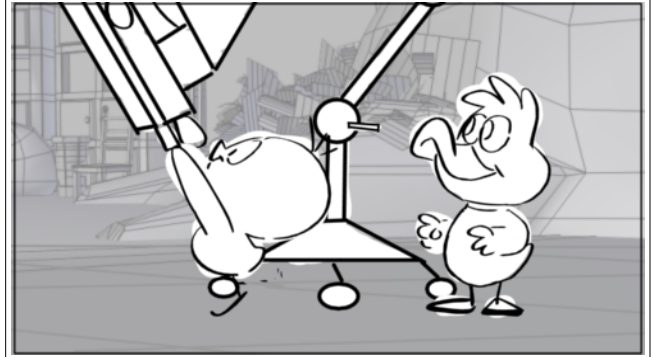
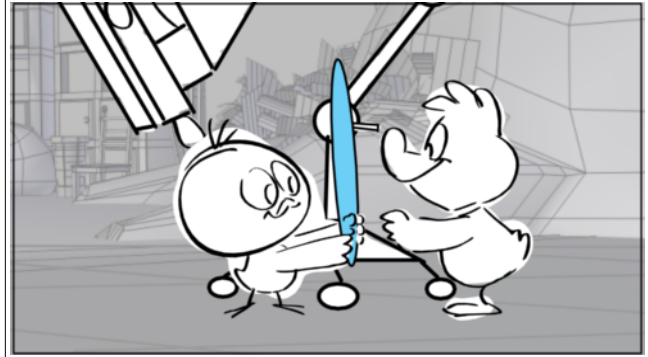
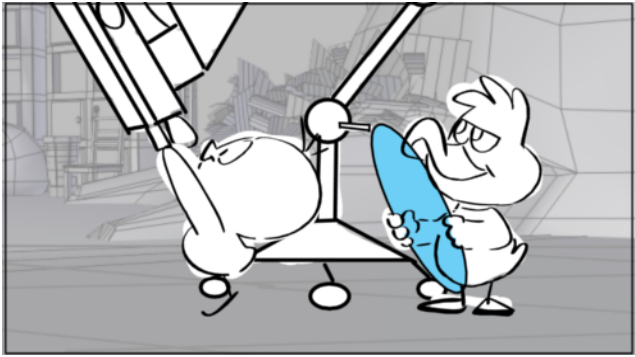

Scene	Duration	Panel	Duration
133	06:09	4	01:10

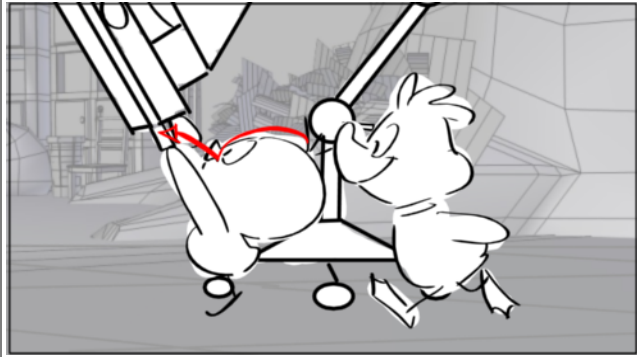

Scene	Duration	Panel	Duration
133	06:09	5	00:21

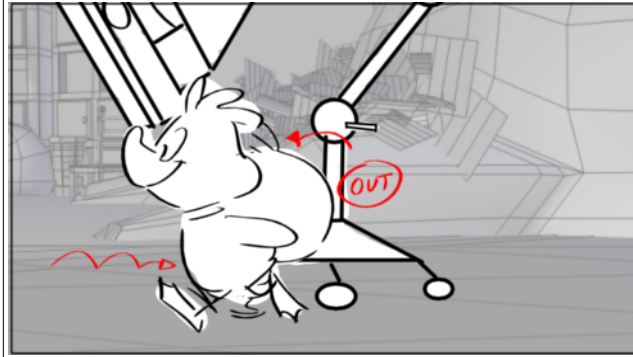

Scene	Duration	Panel	Duration
133	06:09	6	01:00

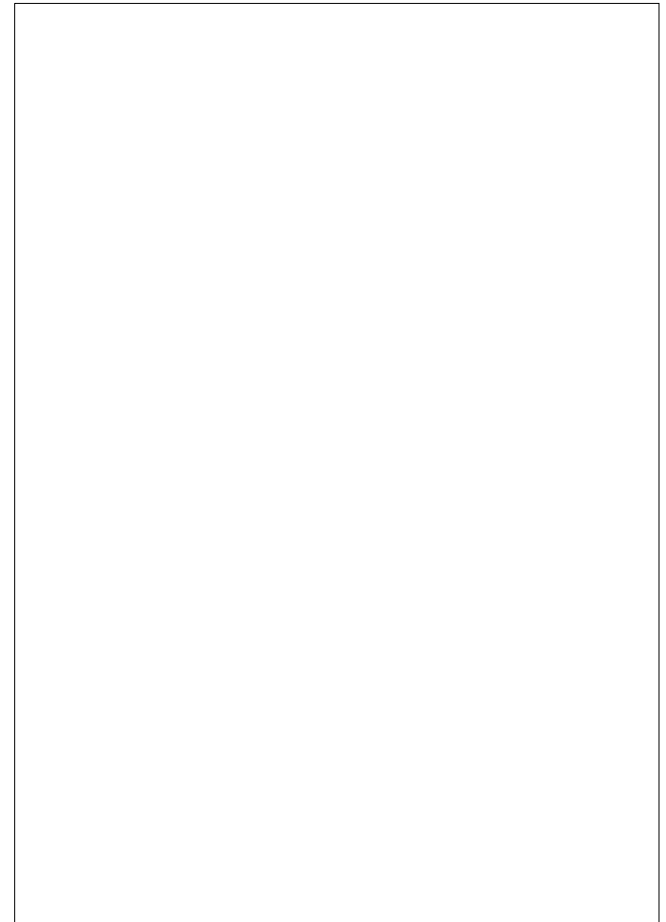
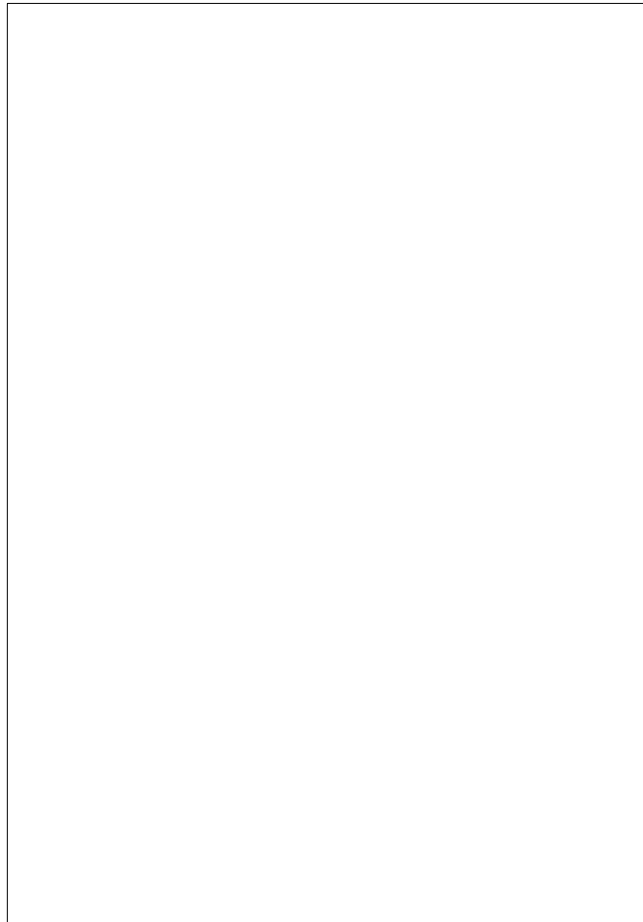
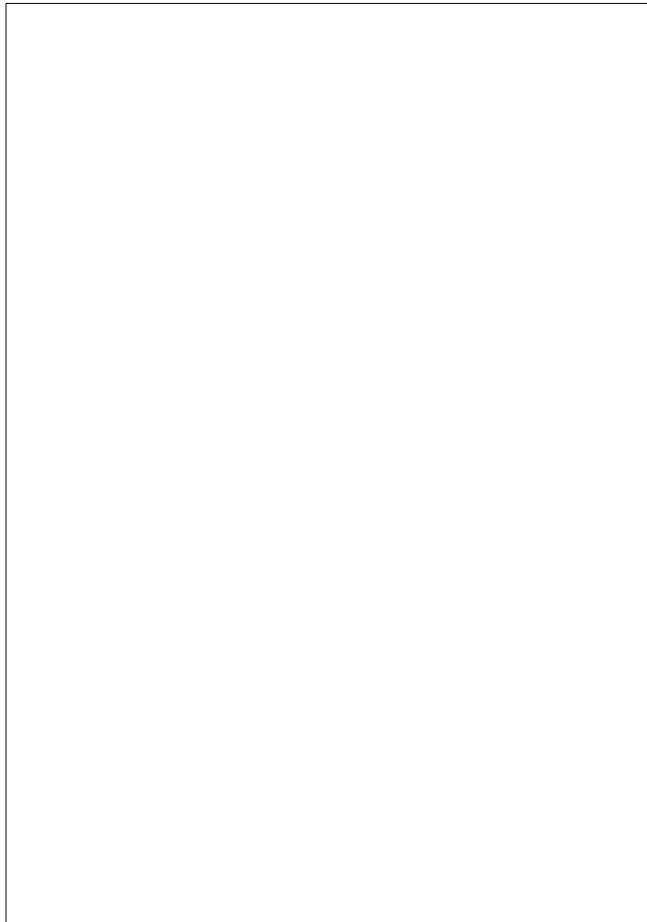
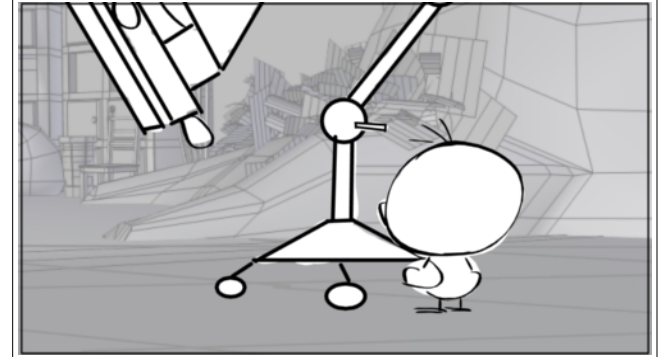

Scene	Duration	Panel	Duration
134	01:12	1	00:10

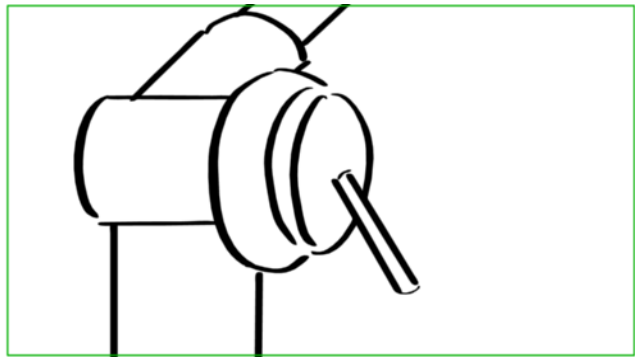

Scene	Duration	Panel	Duration
134	01:12	2	00:10

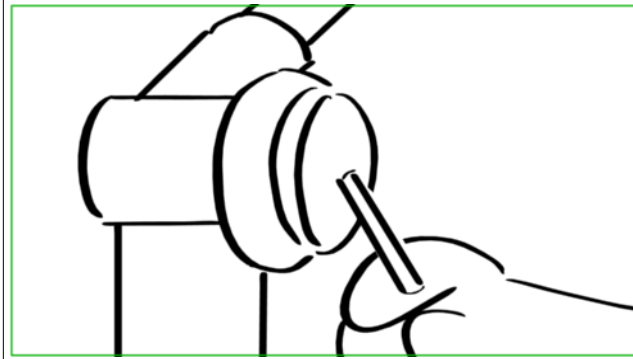

Dialogue

93. CALIMERO (tirant une gélatine bleue du boitier, au taquet)
Allons-y les amis !

Scene	Duration	Panel	Duration
134	01:12	3	00:17

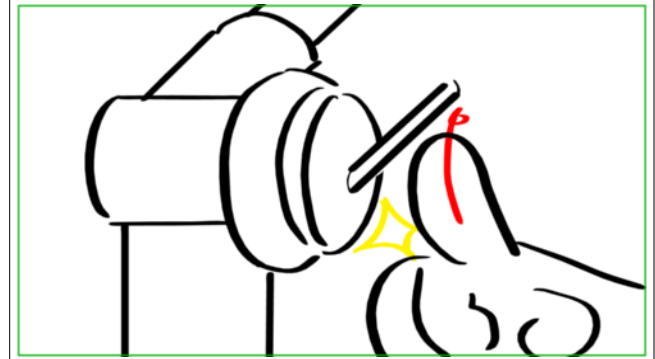

Dialogue

93. CALIMERO (tirant une gélatine bleue du boitier, au taquet)
Allons-y les amis !

Scene	Duration	Panel	Duration
135	01:23	1	00:11

Scene	Duration	Panel	Duration
135	01:23	2	01:12

NO PANEL

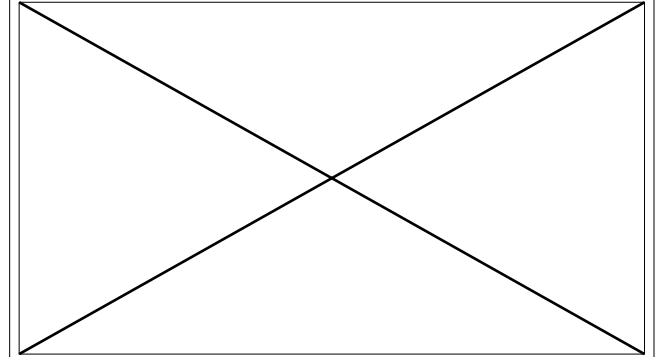
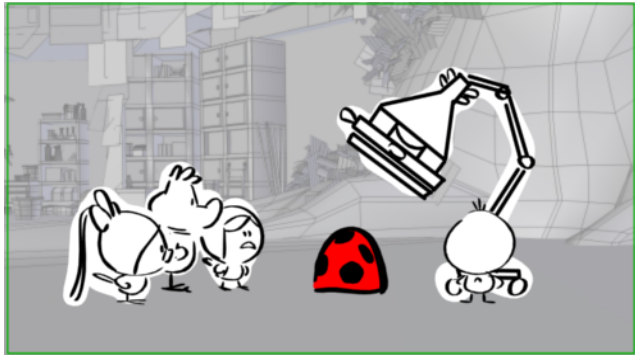

Dialogue
 <SON D'UNE LAMPE A NEON QUI S'ALLUME>



Scene	Duration	Panel	Duration
136	02:16	1	01:00

NO PANEL

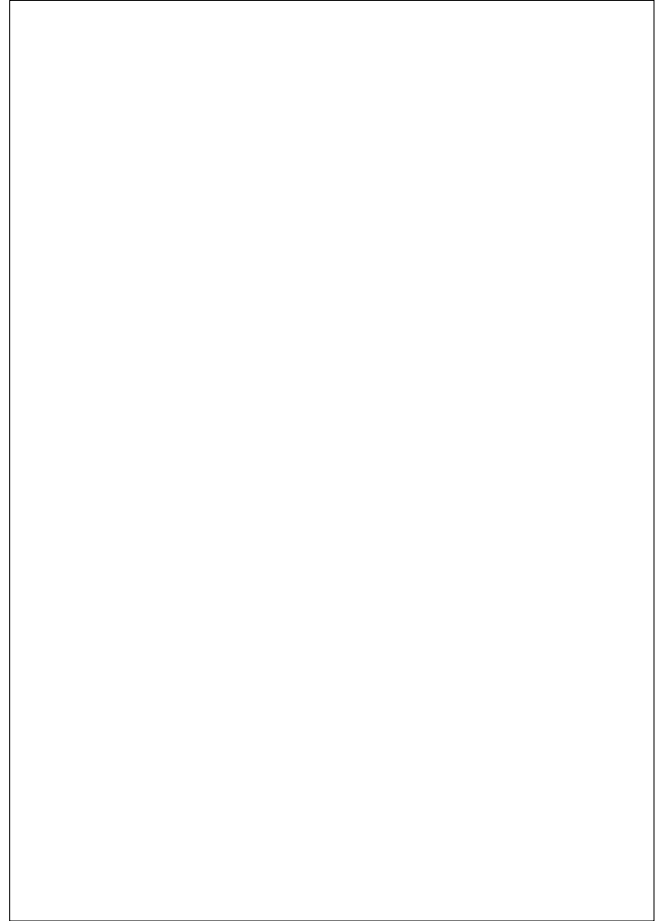
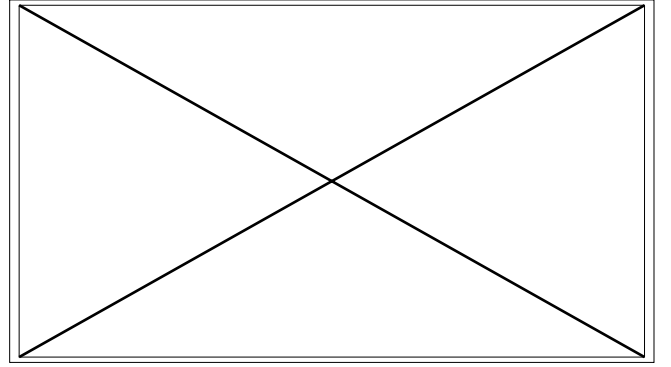
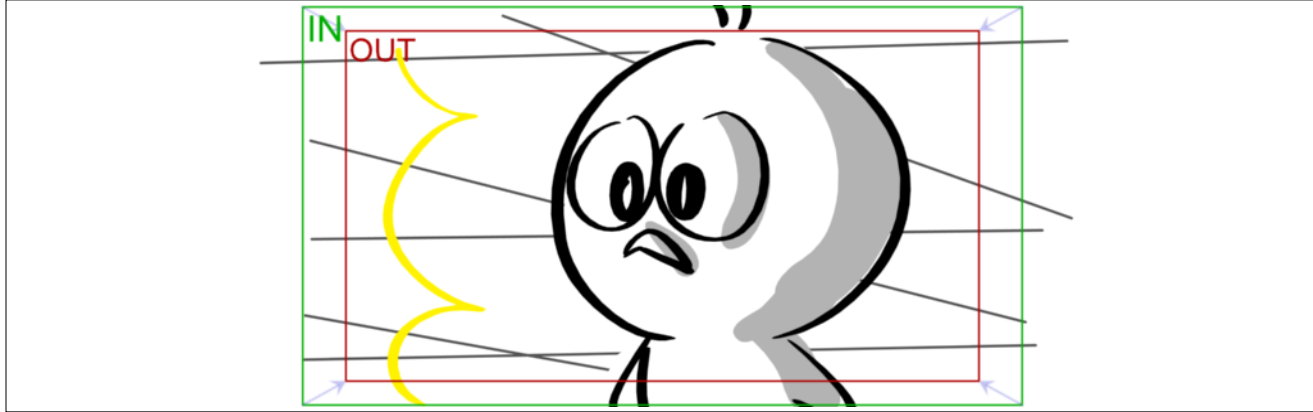



Scene	Duration	Panel	Duration
136	02:16	2	00:09

Scene	Duration	Panel	Duration
136	02:16	3	00:07

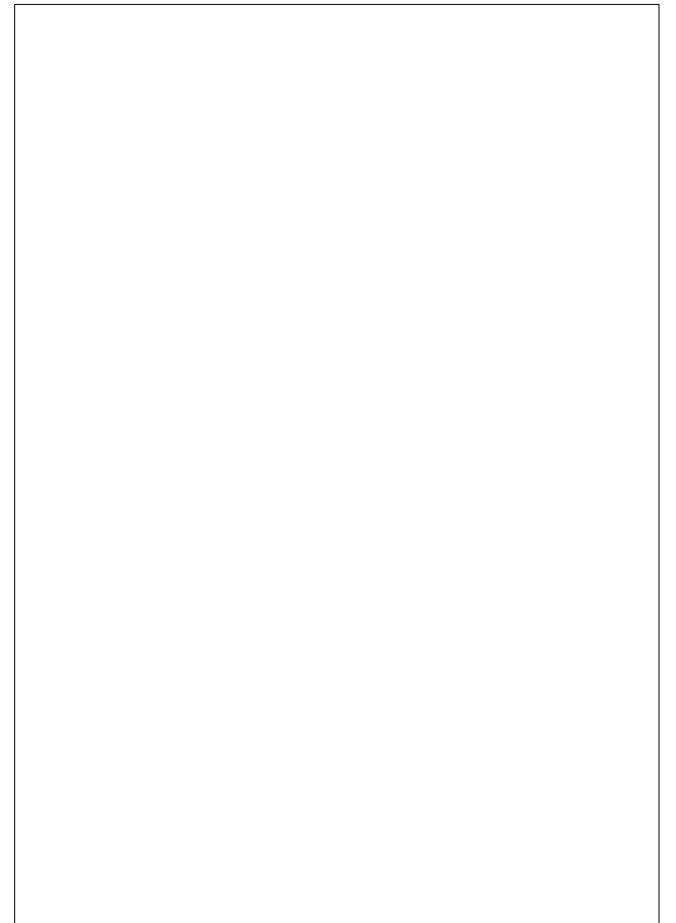
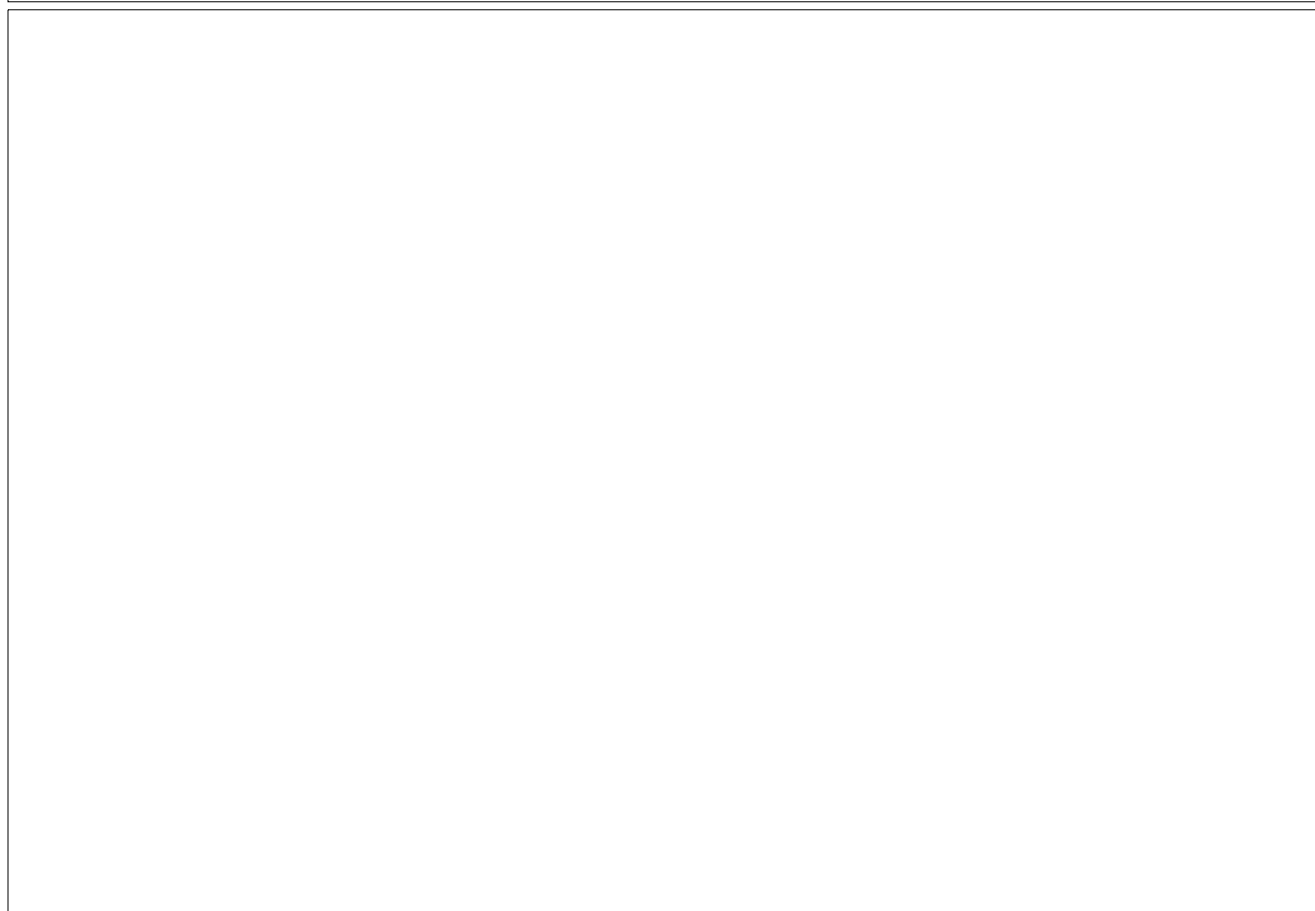
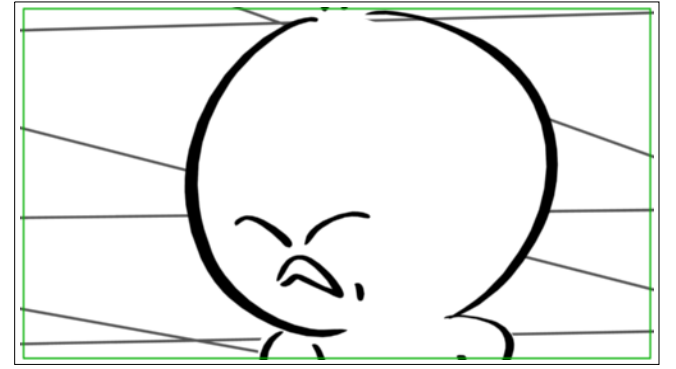
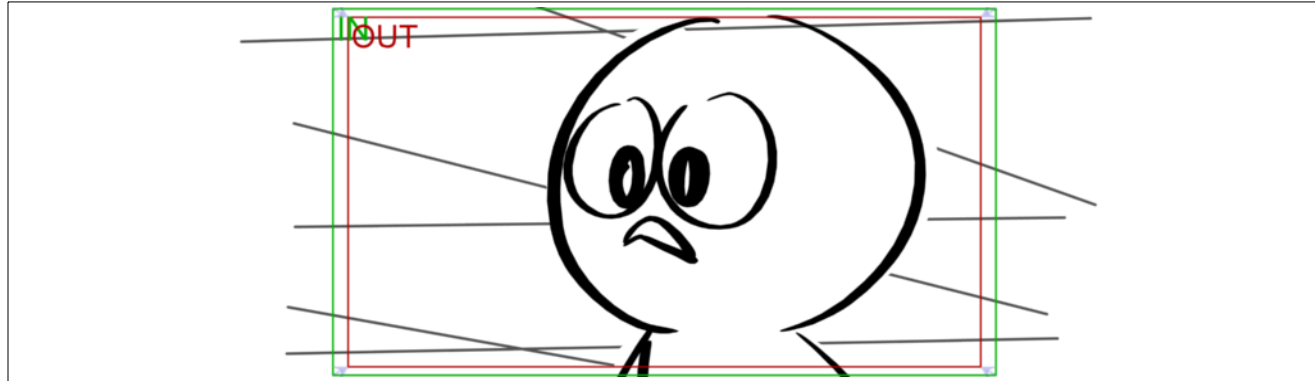

Scene	Duration	Panel	Duration
136	02:16	4	01:00

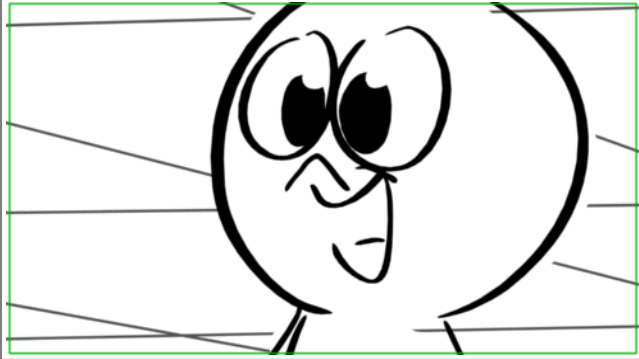

Dialogue
 94. CALIMERO
 Ça a marché !

Scene	Duration	Panel	Duration
137	02:01	1	00:20

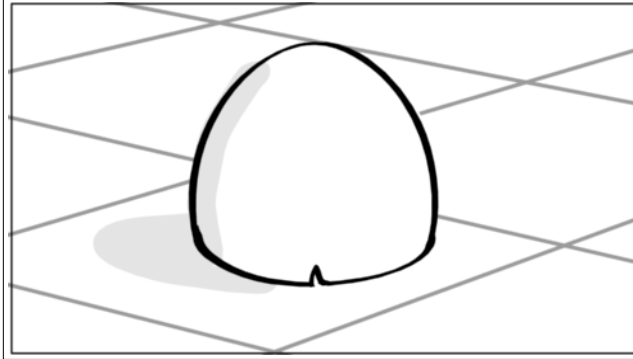

Scene	Duration	Panel	Duration
137	02:01	2	00:16

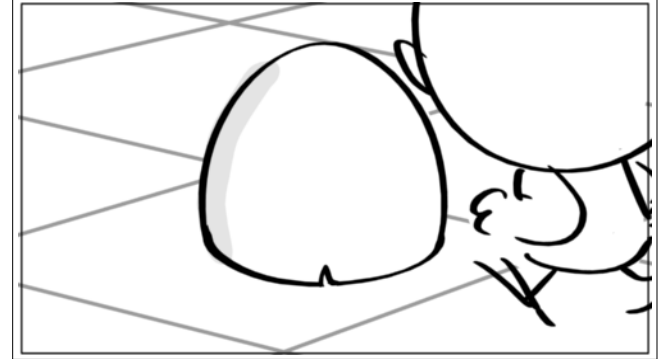

Scene	Duration	Panel	Duration
137	02:01	3	00:15

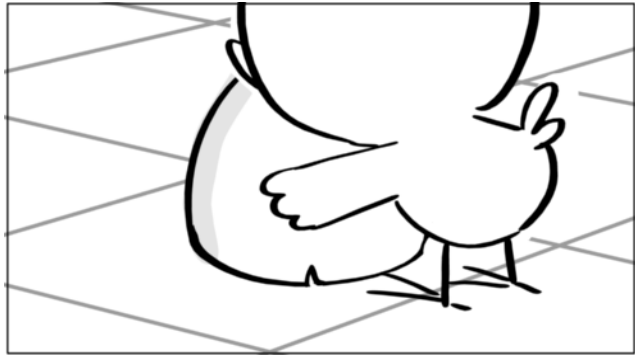

Scene	Duration	Panel	Duration
138	04:16	1	00:09

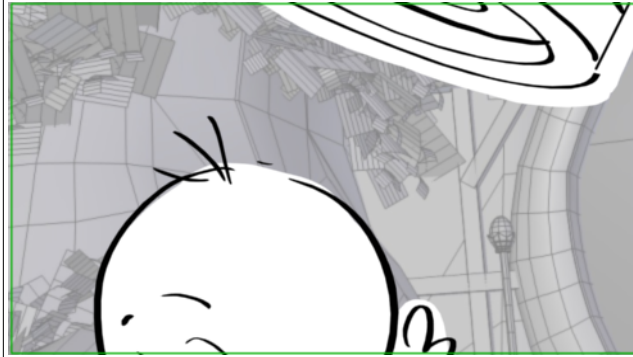

Scene	Duration	Panel	Duration
138	04:16	2	00:20



Dialogue

94. CALIMERO (trop joyeux)
Ma coquille est redevenue toute blanche !

Scene	Duration	Panel	Duration
138	04:16	3	00:15



Dialogue

94. CALIMERO (trop joyeux)
Ma coquille est redevenue toute blanche !

Scene	Duration	Panel	Duration
138	04:16	4	00:21

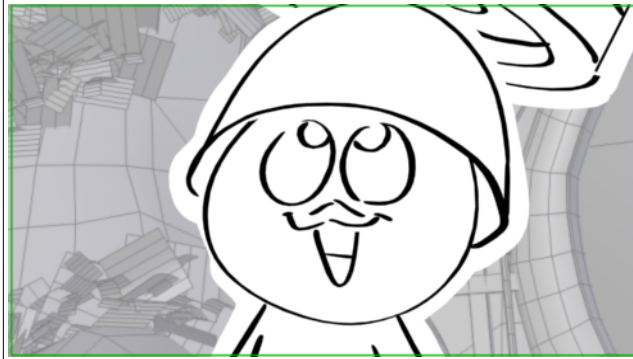

Dialogue

94. CALIMERO (trop joyeux)
Ma coquille est redevenue toute blanche !

Scene	Duration	Panel	Duration
138	04:16	5	00:07



Scene	Duration	Panel	Duration
138	04:16	6	01:00

**Dialogue**

95. CALIMERO (comme flottant dans les airs)
< YOUPI!> ! Je suis tellement heureux que j'ai l'impression de m'envoler !

Scene	Duration	Panel	Duration
138	04:16	7	00:07



Scene	Duration	Panel	Duration
138	04:16	8	00:12

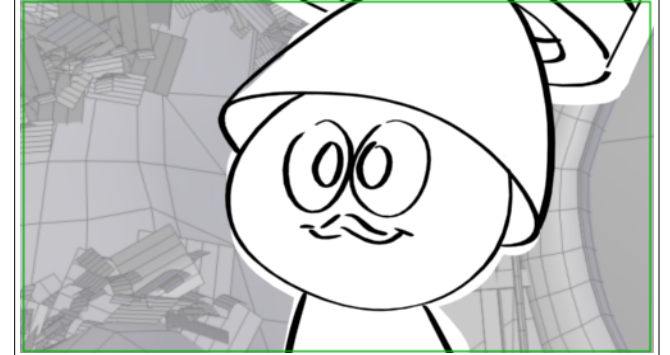



Scene	Duration	Panel	Duration
139	02:00	1	01:00

Scene	Duration	Panel	Duration
139	02:00	2	00:17

Scene	Duration	Panel	Duration
139	02:00	3	00:08

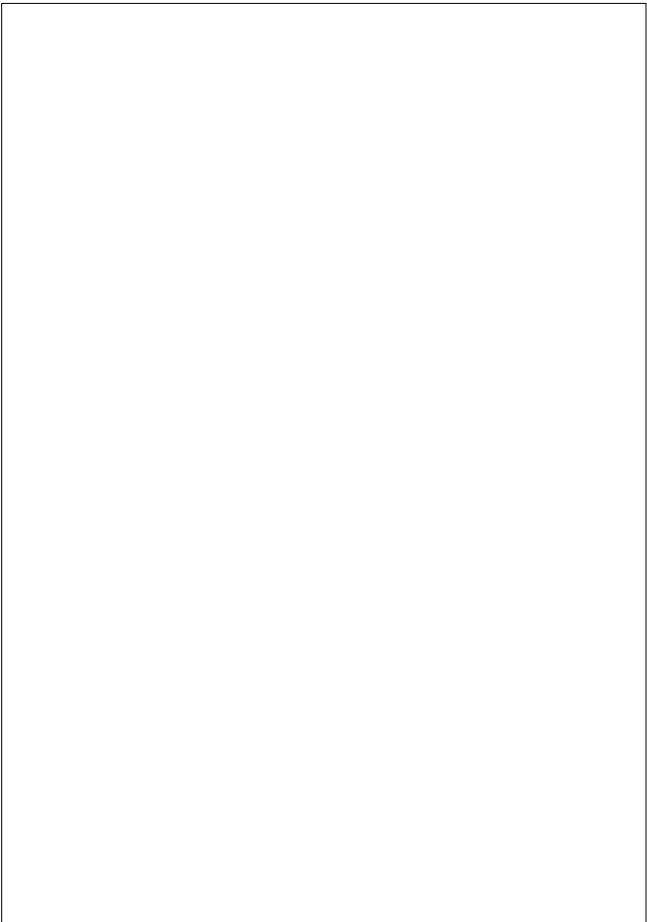
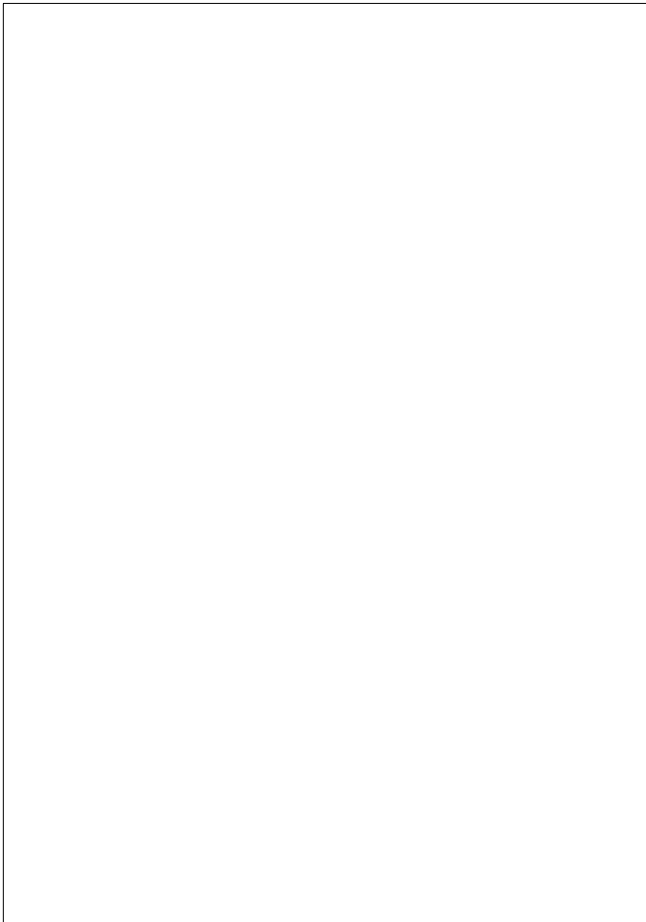
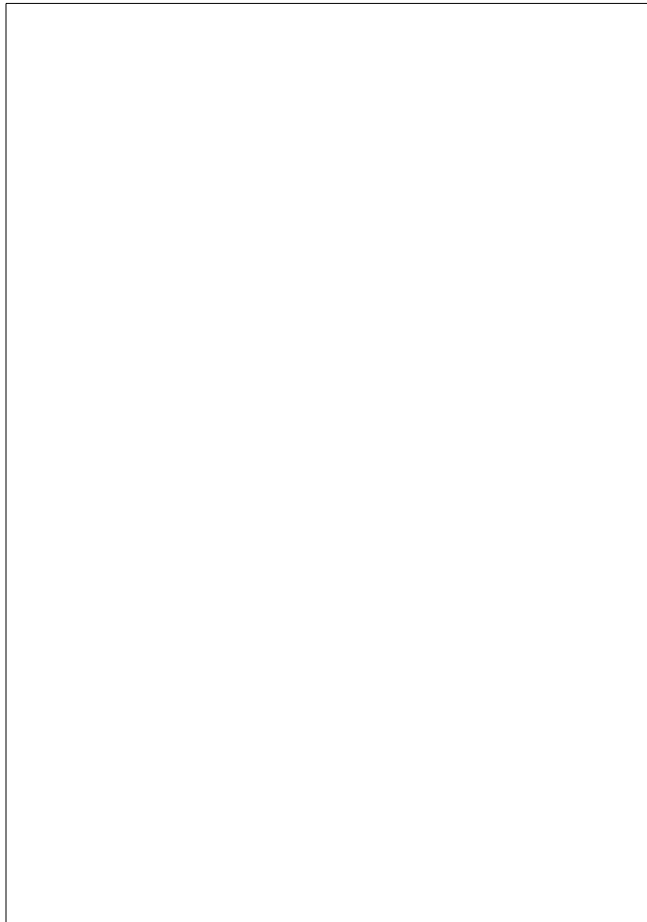
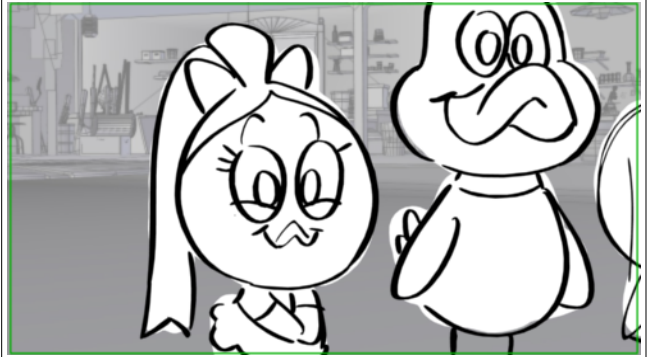
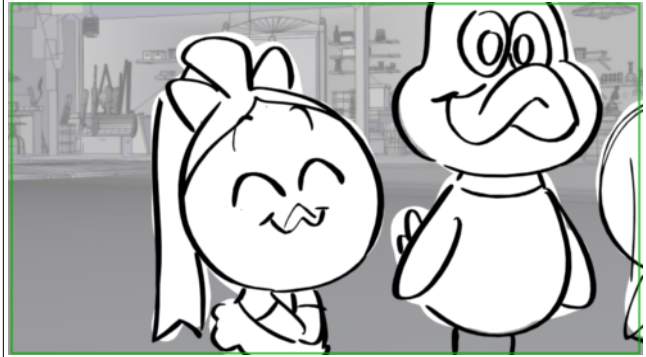
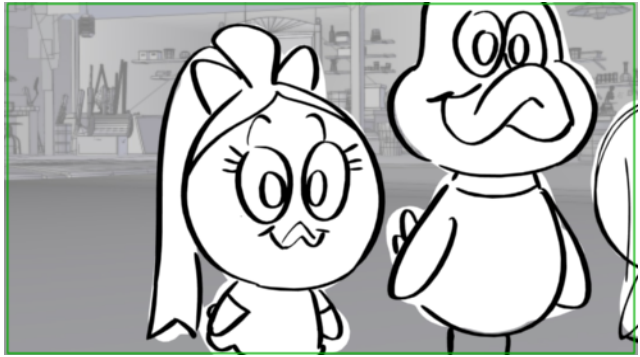

Scene	Duration	Panel	Duration
140	06:01	1	00:23

Scene	Duration	Panel	Duration
140	06:01	2	00:18

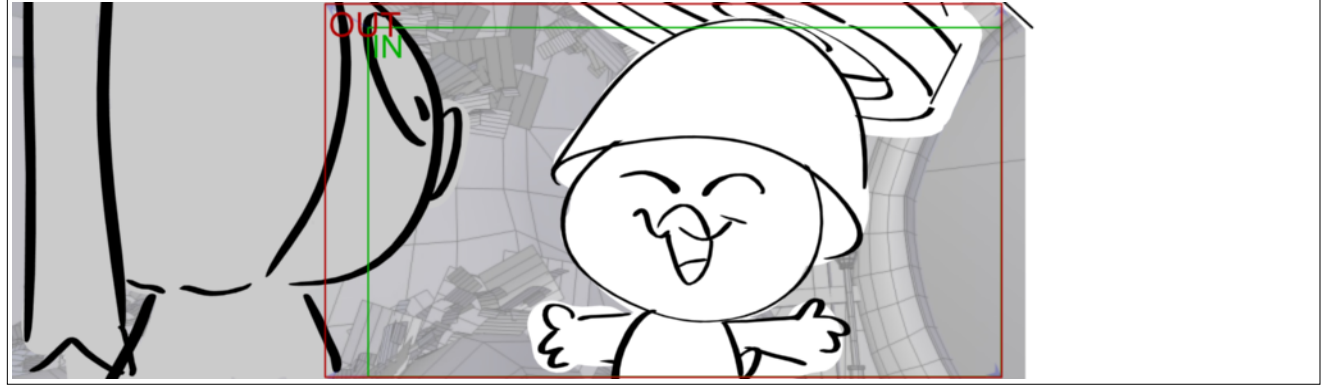

Dialogue
 96. CALIMERO
 Et maintenant, Priscilla,

Dialogue
 96. CALIMERO
 place à la surprise !

Scene	Duration	Panel	Duration
140	06:01	3	02:02

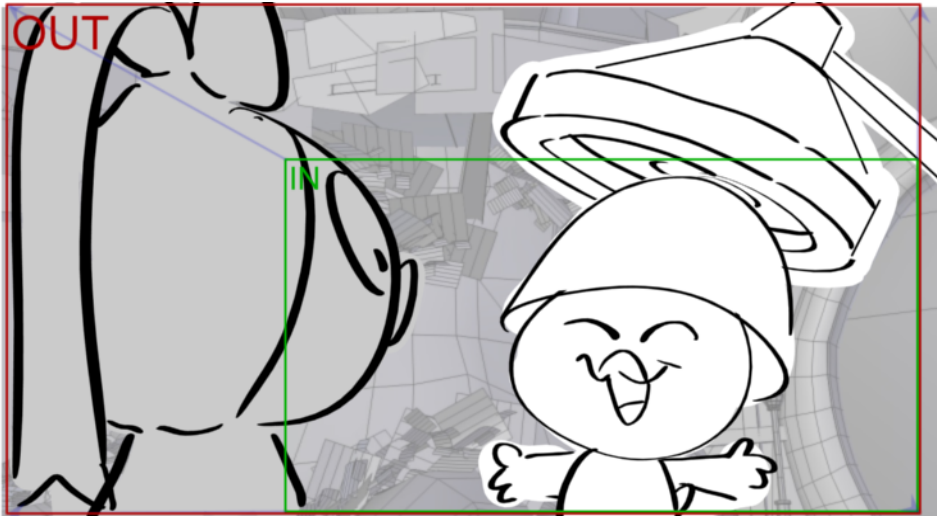

Dialogue
 96. CALIMERO
 place à la surprise !

Scene	Duration	Panel	Duration
140	06:01	4	02:08

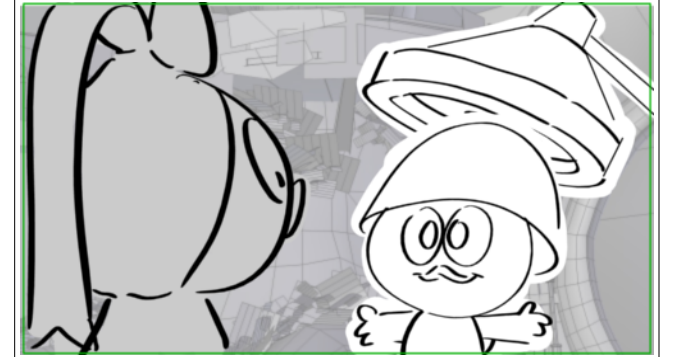

Dialogue
 96. CALIMERO
 place à la surprise !



Dissolve	Duration 00:24
----------	-------------------

Scene 141	Duration 03:12	Panel 1	Duration 03:12
--------------	-------------------	------------	-------------------

Scene 142	Duration 01:18	Panel 1	Duration 00:15
--------------	-------------------	------------	-------------------

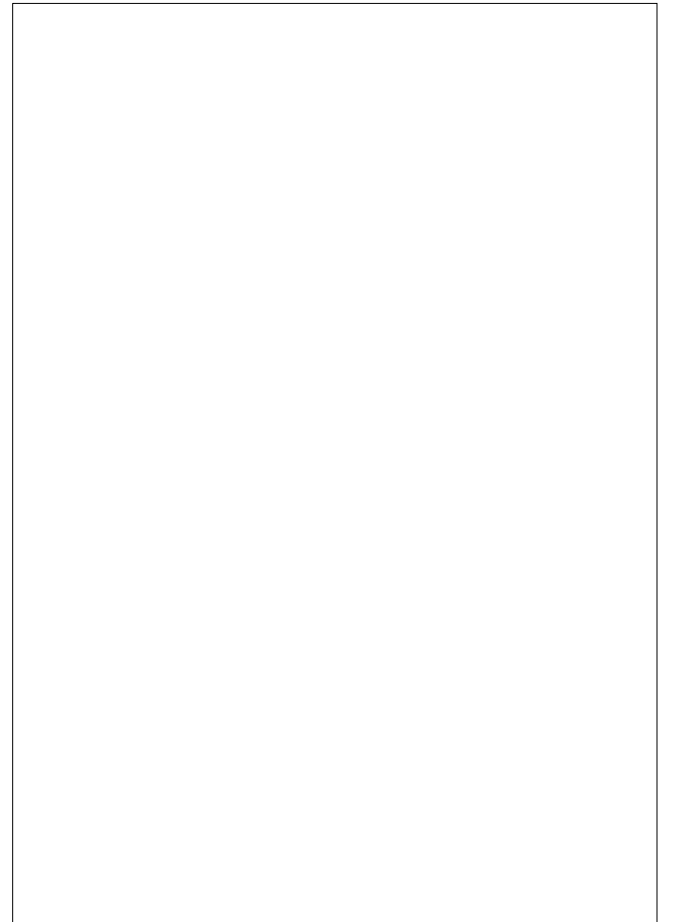
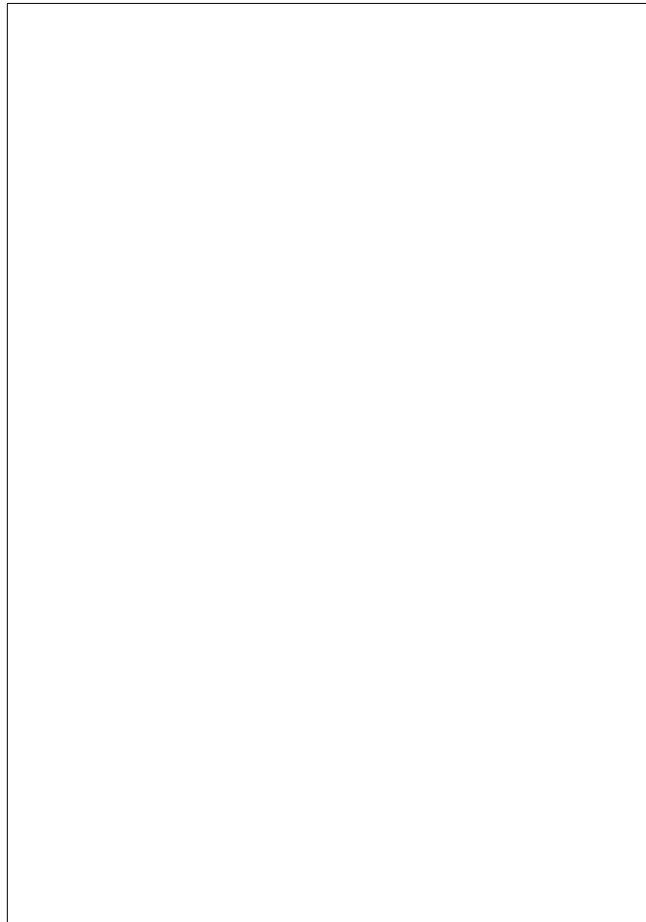
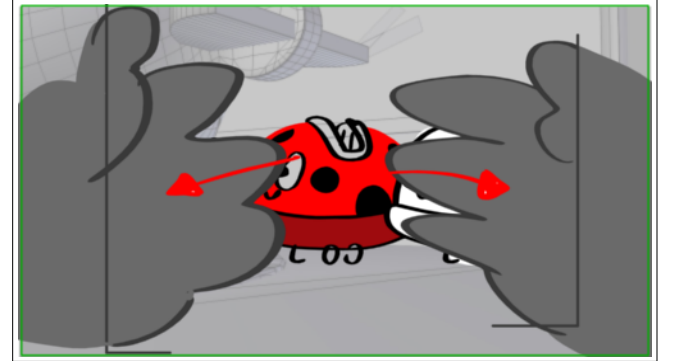

Scene	Duration	Panel	Duration
142	01:18	2	00:06

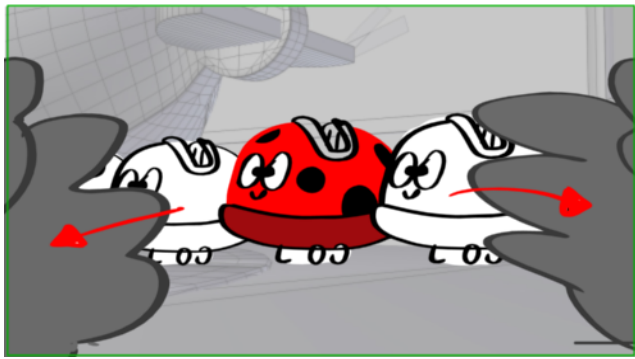

Scene	Duration	Panel	Duration
142	01:18	3	00:22

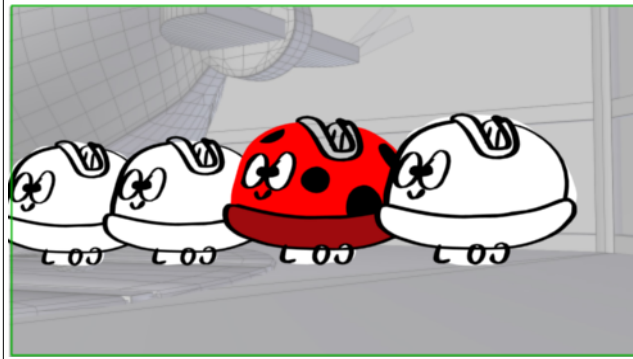

Dialogue
 98. PRISCILLA (agréablement surprise)
 Une Coccinelle ?

Scene	Duration	Panel	Duration
143	10:11	1	01:00

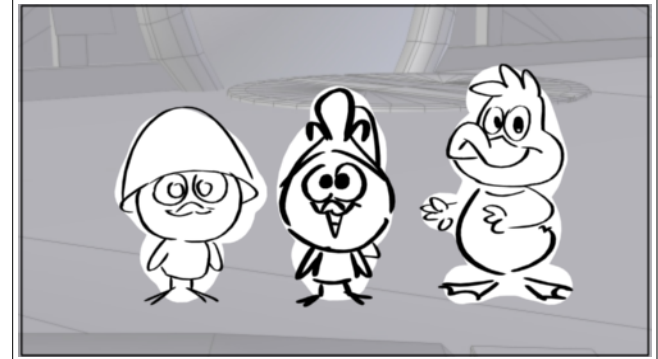

Scene	Duration	Panel	Duration
143	10:11	2	00:08

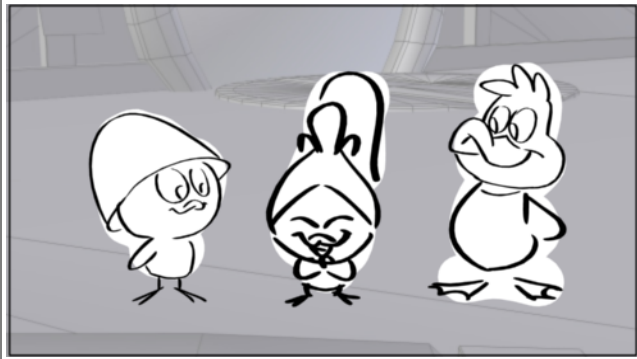

Dialogue

99. PRISCILLA (émue)
J'en rêvais !

Scene	Duration	Panel	Duration
143	10:11	3	00:08

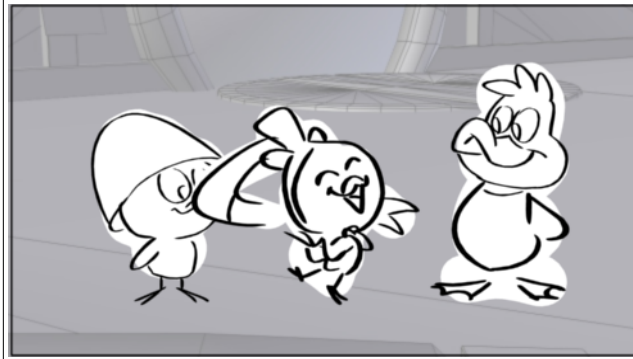

Dialogue

99. PRISCILLA (émue)
J'en rêvais !

Scene	Duration	Panel	Duration
143	10:11	4	00:08

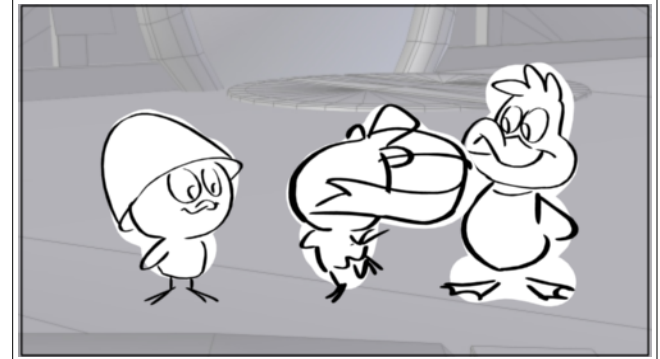

Dialogue

99. PRISCILLA (émue)
J'en rêvais !

Scene	Duration	Panel	Duration
143	10:11	5	00:08

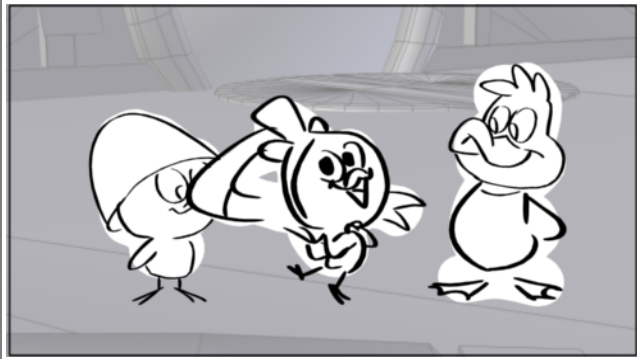

Dialogue

99. PRISCILLA (émue)
J'en rêvais !

Scene	Duration	Panel	Duration
143	10:11	6	03:22

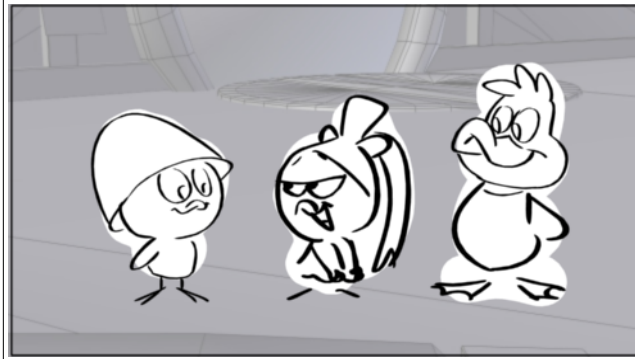

Dialogue

98. PRISCILLA (agréablement surprise)
Merci Caliméro ! C'est toi qui as eu
cette idée?

Scene	Duration	Panel	Duration
143	10:11	7	01:00

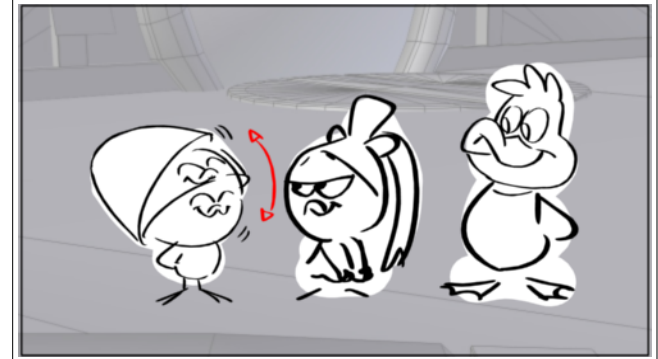

Dialogue

Caliméro opine du chef.

Scene	Duration	Panel	Duration
143	10:11	8	00:24

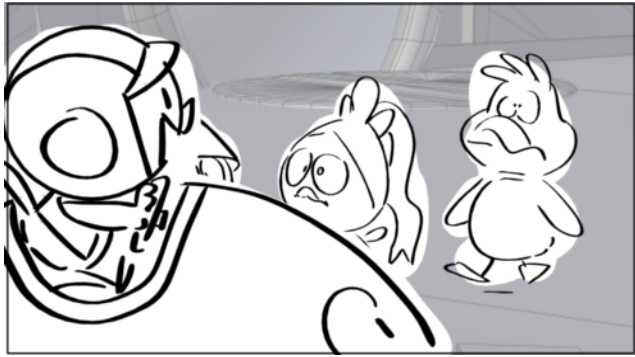

Dialogue

100. VALERIANO (fonceur)
Et c'est parti pour les coccinelles en folie !

Scene	Duration	Panel	Duration
143	10:11	9	00:22

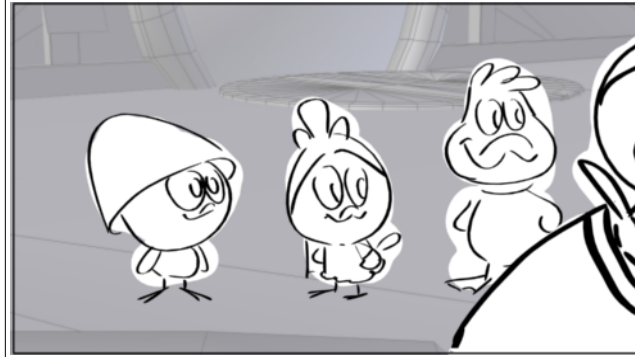

Dialogue

100. VALERIANO (fonceur)
Et c'est parti pour les coccinelles en folie !

Scene	Duration	Panel	Duration
143	10:11	10	00:04

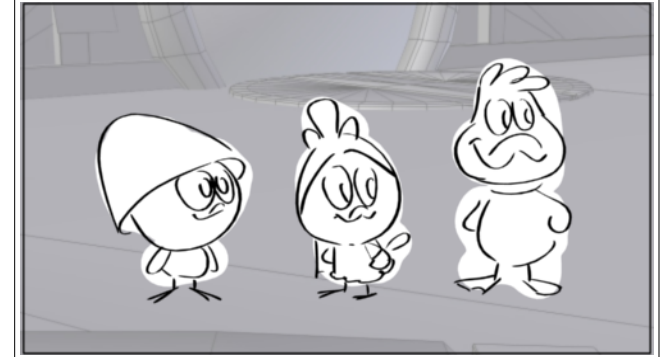

Dialogue

100. VALERIANO (fonceur)
Et c'est parti pour les coccinelles en folie !

Scene	Duration	Panel	Duration
143	10:11	11	00:16



Dialogue
 100. VALERIANO (fonceur)
 Et c'est parti pour les coccinelles en folie !

Scene	Duration	Panel	Duration
143	10:11	12	00:16

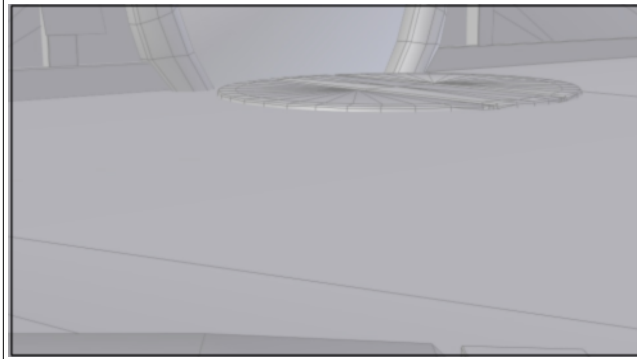

Dialogue
 100. VALERIANO (fonceur)
 Et c'est parti pour les coccinelles en folie !

Scene	Duration	Panel	Duration
144	08:16	1	00:11

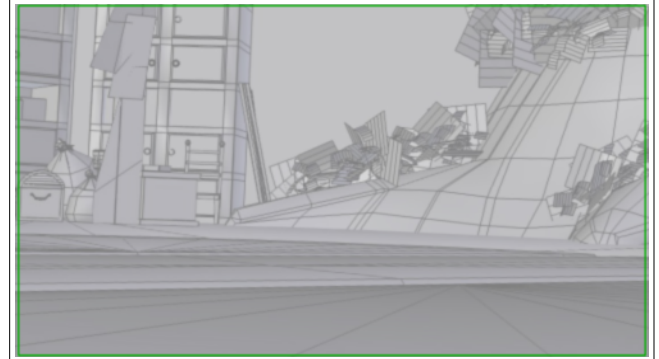

Scene	Duration	Panel	Duration
144	08:16	2	01:00

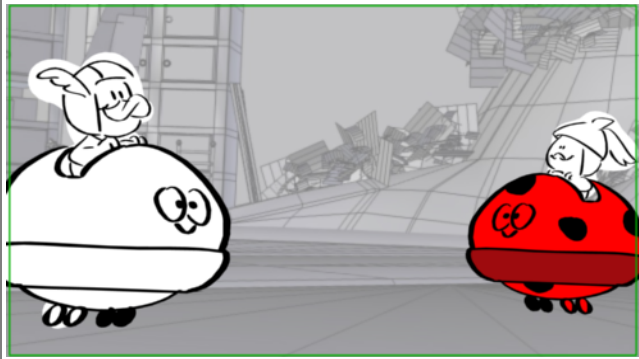

Scene	Duration	Panel	Duration
144	08:16	3	01:00

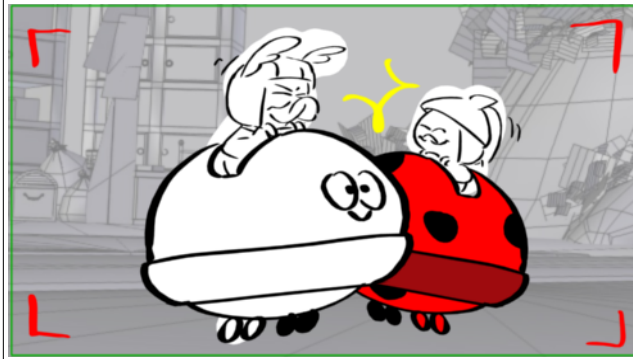

Dialogue
<BANG>

Scene	Duration	Panel	Duration
144	08:16	4	03:04

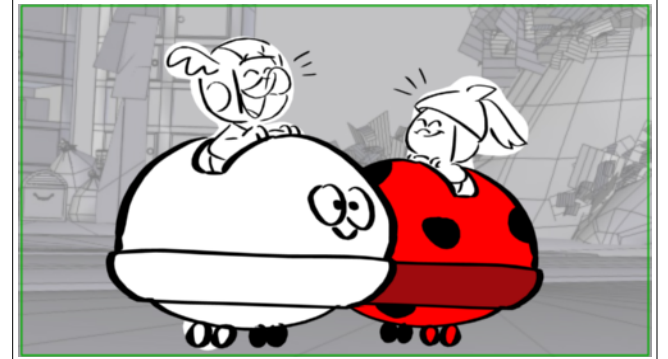

Dialogue
101. PIERROT (un peu sonné)
Les copains, c'est la première fois que
je me prends un coup de coccinelle !

Scene	Duration	Panel	Duration
144	08:16	5	00:13

Scene	Duration	Panel	Duration
144	08:16	6	00:24

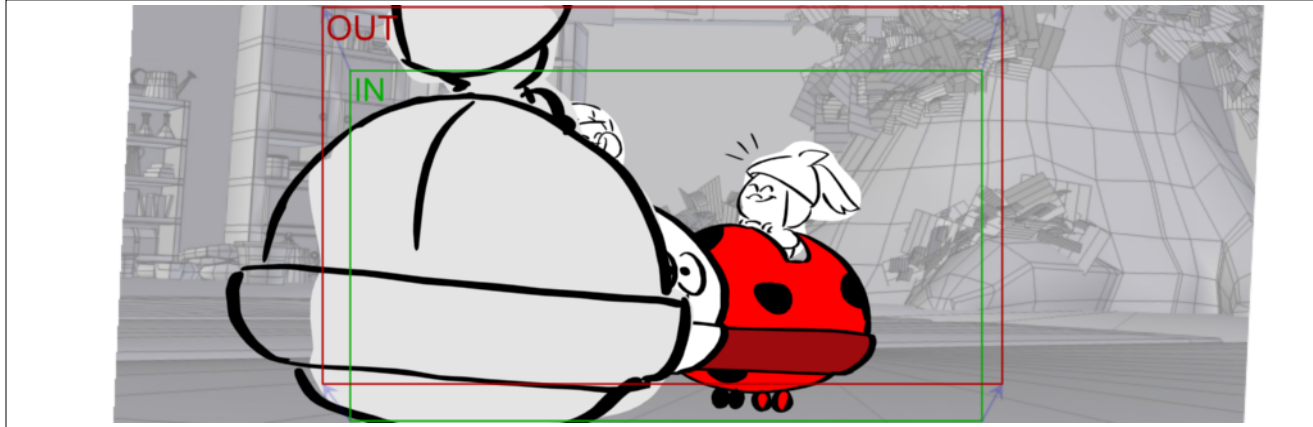

Dialogue
<BANG>



Dialogue
<BANG>



Scene	Duration	Panel	Duration
144	08:16	7	00:13

Scene	Duration	Panel	Duration
144	08:16	8	01:01

NO PANEL

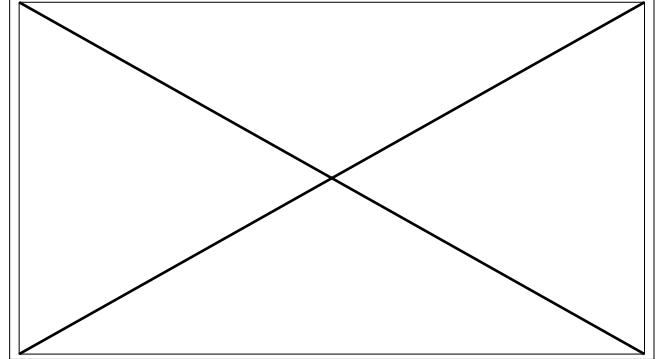
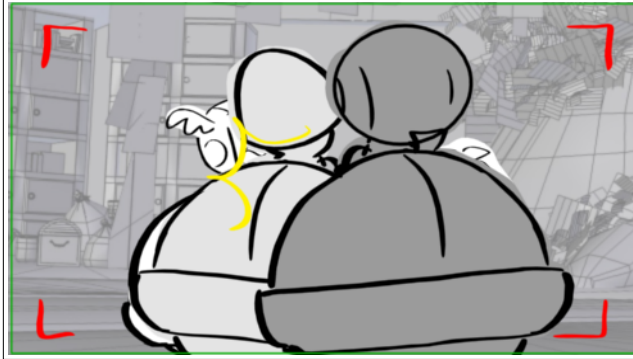

Dialogue

<BANG>

Dialogue

<BANG>

Scene	Duration	Panel	Duration
145	04:00	1	01:00

NO PANEL

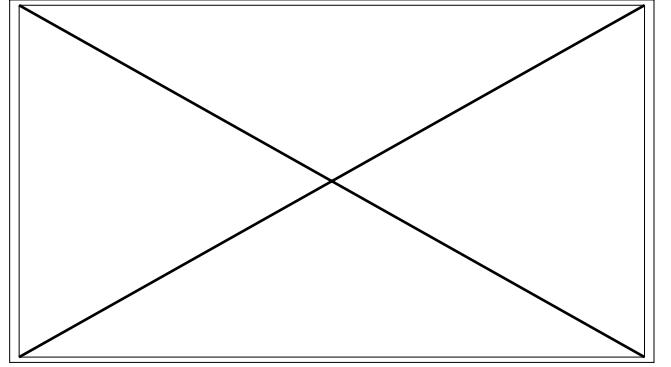
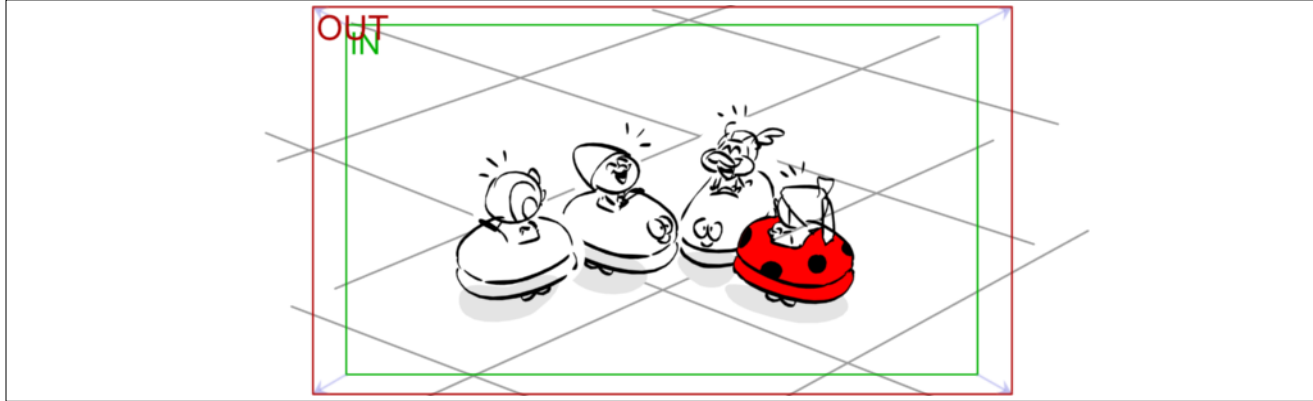

Dialogue

102. CALIMERO / PRISCILLA (en chœur)
 < HA HA HA, HI HI HI >

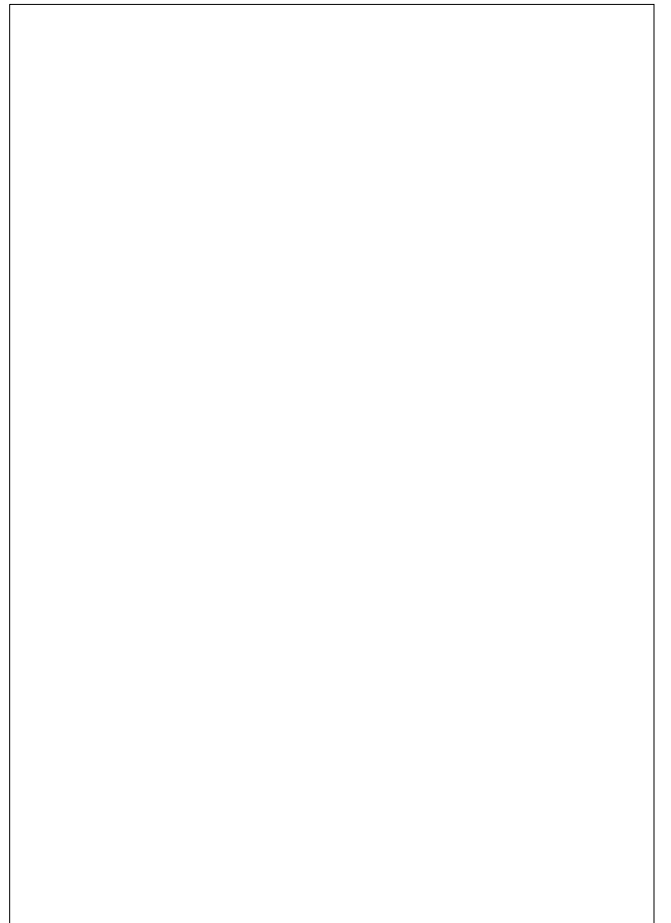



Scene	Duration	Panel	Duration
145	04:00	2	01:00

NO PANEL

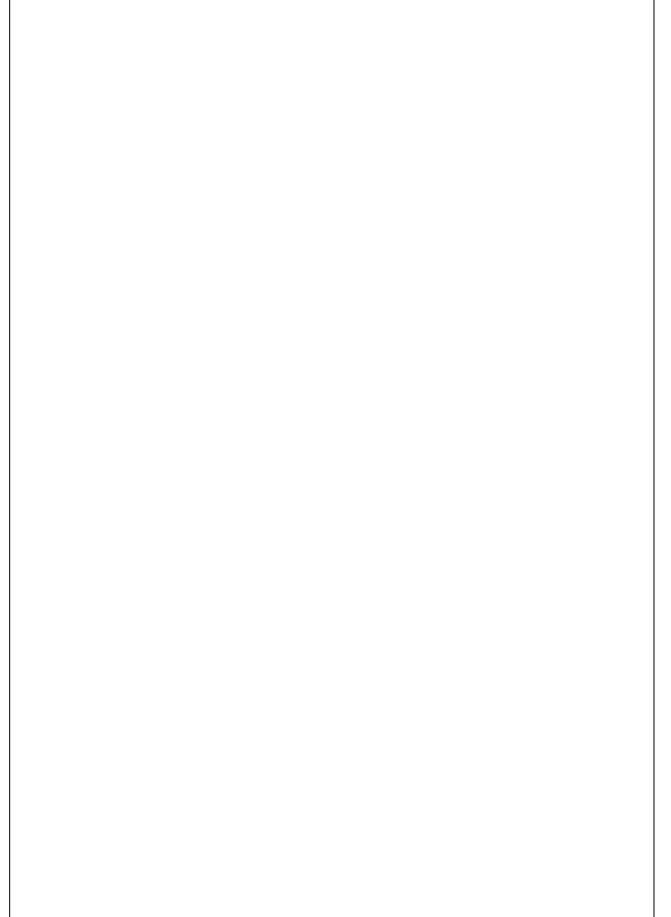
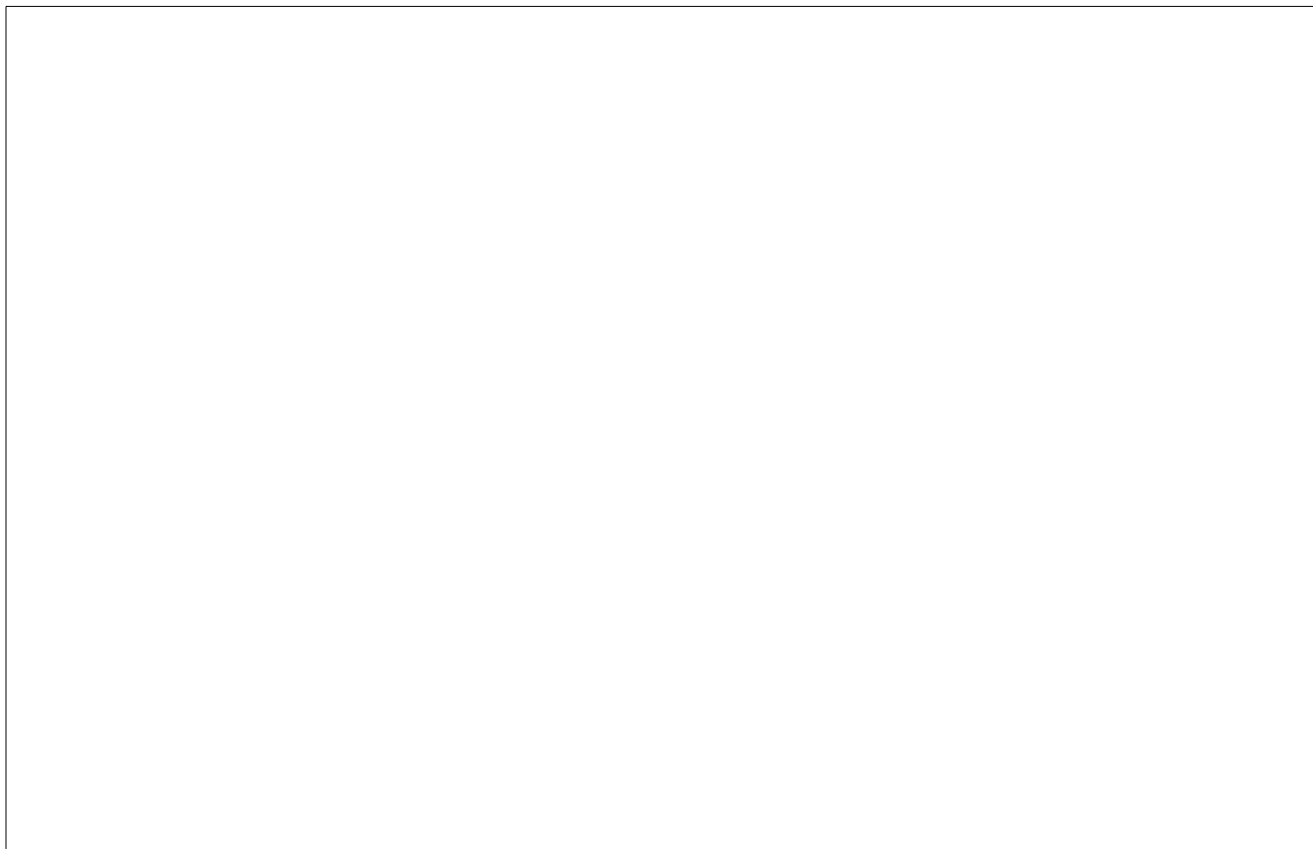
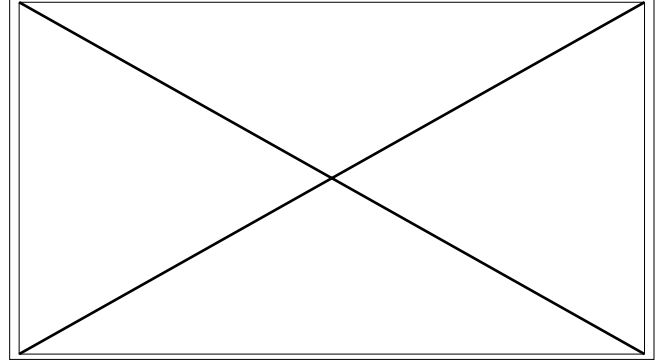
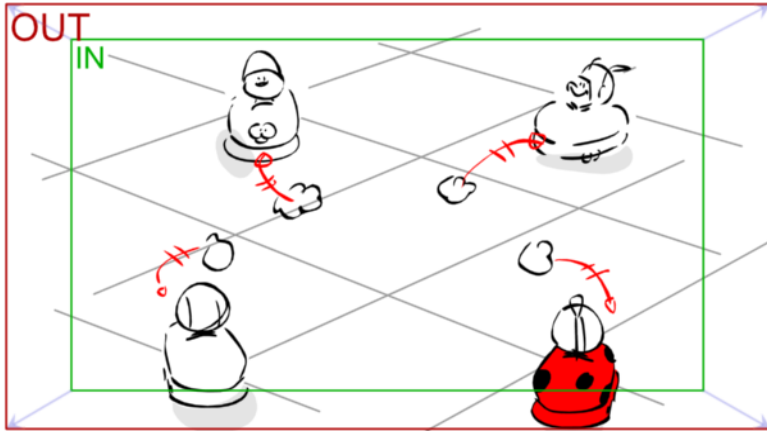

Scene	Duration	Panel	Duration
145	04:00	3	01:00

Scene	Duration	Panel	Duration
145	04:00	4	01:00

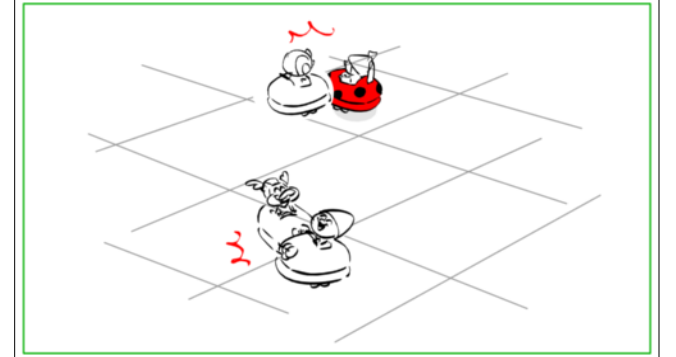
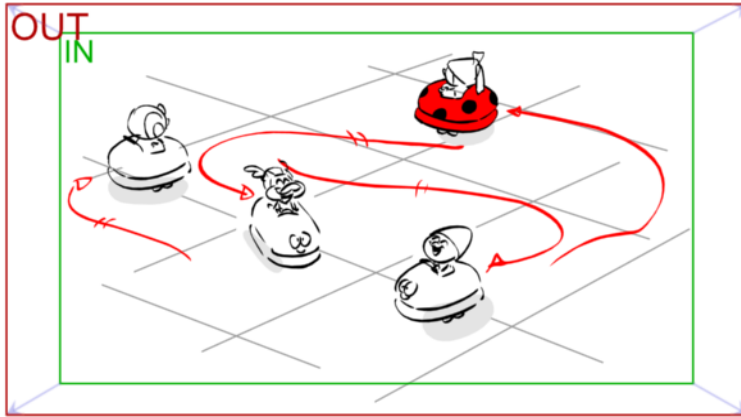

Dialogue

<BANG>