

Episode 19

Calimero fait son cinéma



| | | | |
|-------|----------|-------|----------|
| Scene | Duration | Panel | Duration |
| 1 | 04:01 | 1 | 03:12 |

NO PANEL

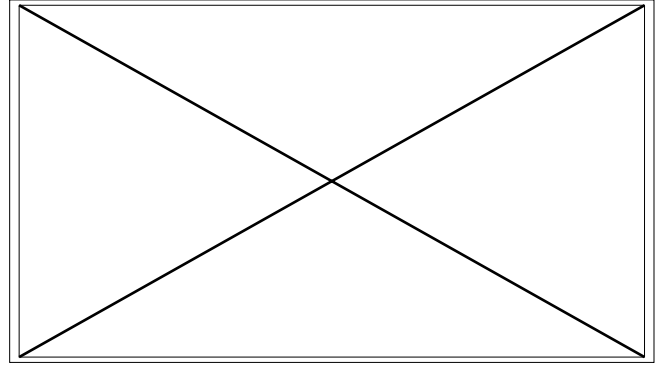

Action Notes

- 1. PLACE BASSE ? CINEMA / EXT. JOUR

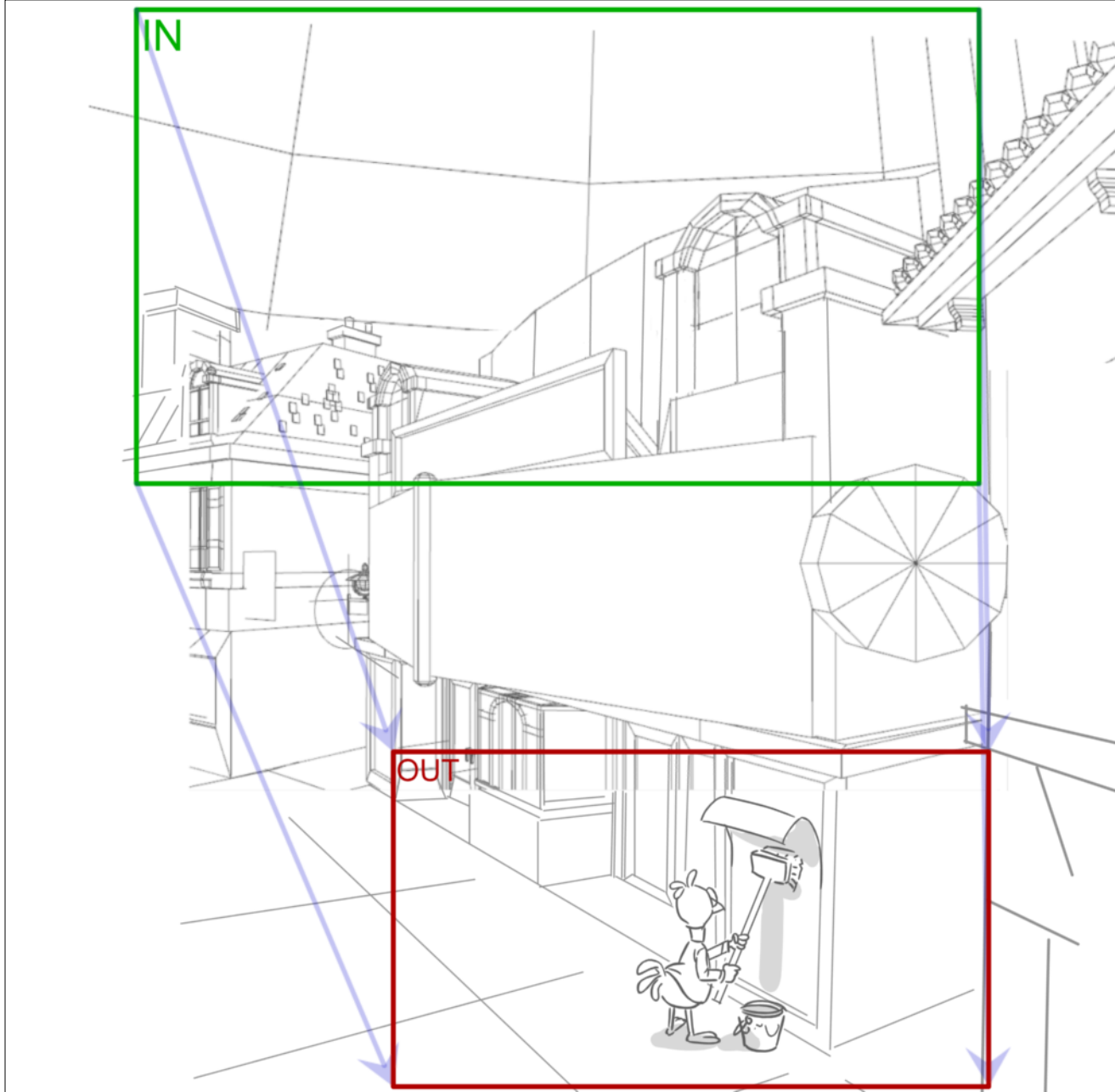

| Scene | Duration | Panel | Duration |
|-------|----------|-------|----------|
| 1 | 04:01 | 2 | 00:14 |



Action Notes

Monsieur Kinos, le directeur du cinéma recollant l'affiche du concours sur un panneau devant le cinéma.

| Scene | Duration | Panel | Duration |
|-------|----------|-------|----------|
| 2 | 01:09 | 1 | 00:08 |

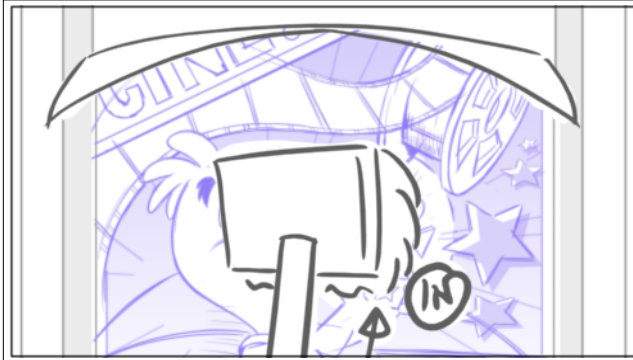

Dialogue

1. MR KINOS (ronchonnant)
Grmpf !

| Scene | Duration | Panel | Duration |
|-------|----------|-------|----------|
| 2 | 01:09 | 2 | 00:07 |

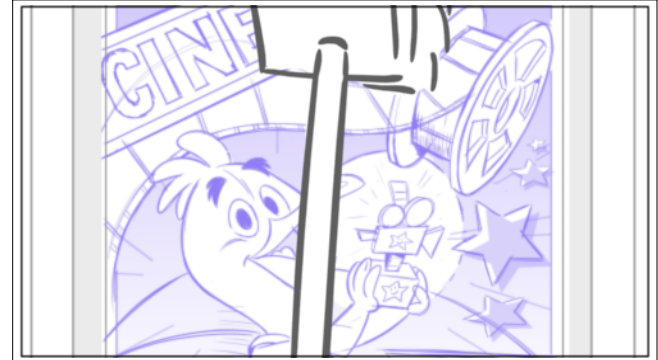

Dialogue

1. MR KINOS (ronchonnant)
Grmpf !

| Scene | Duration | Panel | Duration |
|-------|----------|-------|----------|
| 2 | 01:09 | 3 | 00:07 |

| Scene | Duration | Panel | Duration |
|-------|----------|-------|----------|
| 2 | 01:09 | 4 | 00:07 |

| Scene | Duration | Panel | Duration |
|-------|----------|-------|----------|
| 2 | 01:09 | 5 | 00:05 |

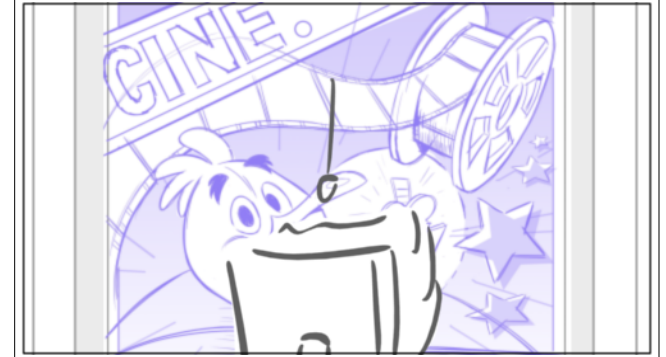
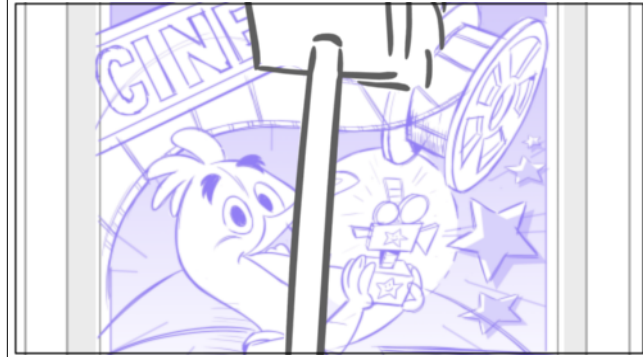
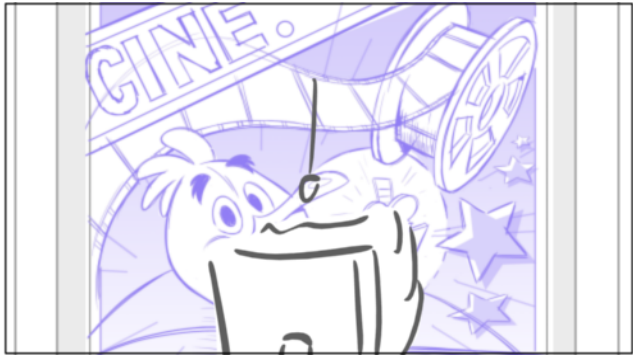

Dialogue
 1. MR KINOS (ronchonnant)
 Grmpf !

| Scene | Duration | Panel | Duration |
|-------|----------|-------|----------|
| 3 | 02:23 | 1 | 00:09 |

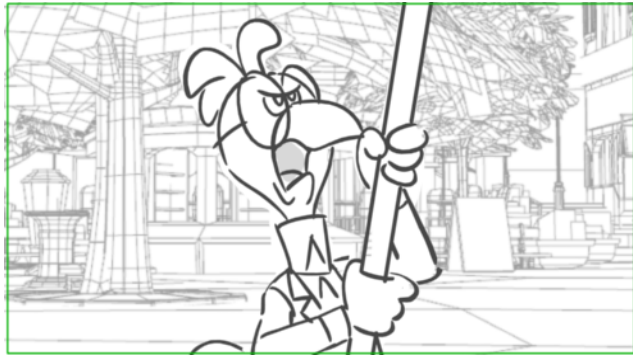

Dialogue

1. MR KINOS (ronchonnant)
C'est la dixième fois que je la recolle !

| Scene | Duration | Panel | Duration |
|-------|----------|-------|----------|
| 3 | 02:23 | 2 | 00:07 |

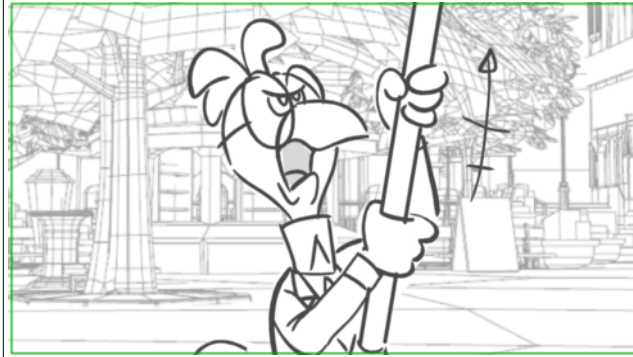

| Scene | Duration | Panel | Duration |
|-------|----------|-------|----------|
| 3 | 02:23 | 3 | 00:09 |

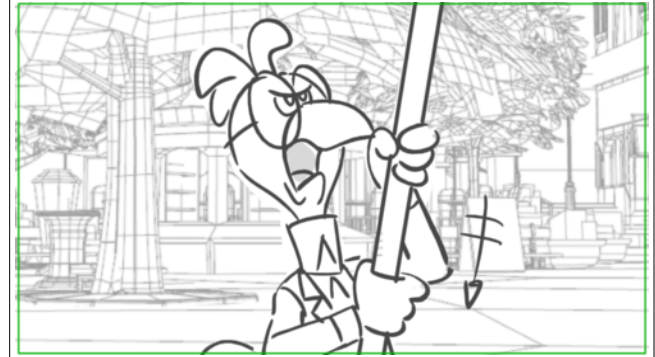

| Scene | Duration | Panel | Duration |
|-------|----------|-------|----------|
| 3 | 02:23 | 4 | 00:07 |



| Scene | Duration | Panel | Duration |
|-------|----------|-------|----------|
| 3 | 02:23 | 5 | 00:16 |

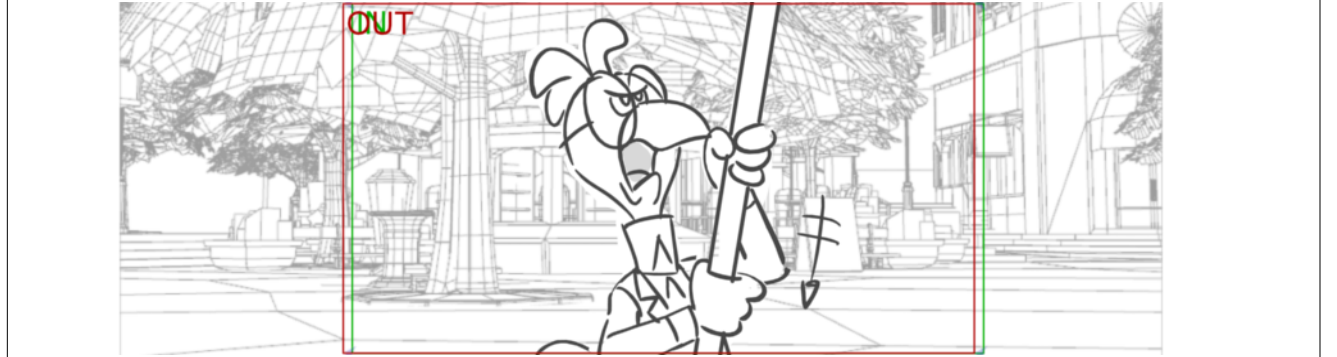

Dialogue

1. MR KINOS (ronchonnant)MODIF
Si je tenais le chenapan

| Scene | Duration | Panel | Duration |
|-------|----------|-------|----------|
| 3 | 02:23 | 6 | 01:00 |

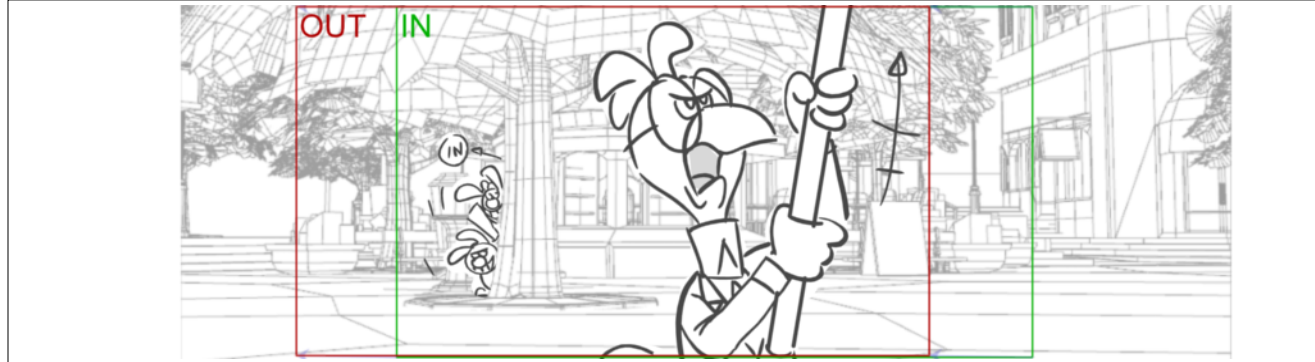

Dialogue

1. MR KINOS (ronchonnant)MODIF
qui passe son temps à voler mon affiche !

Action Notes

LAPINETS IN derrière l'arbre

| Scene | Duration | Panel | Duration |
|-------|----------|-------|----------|
| 4 | 04:07 | 1 | 00:13 |



Action Notes

COT tient une affiche roulée

| Scene | Duration | Panel | Duration |
|-------|----------|-------|----------|
| 4 | 04:07 | 2 | 01:00 |

| Scene | Duration | Panel | Duration |
|-------|----------|-------|----------|
| 4 | 04:07 | 3 | 01:00 |

NO PANEL

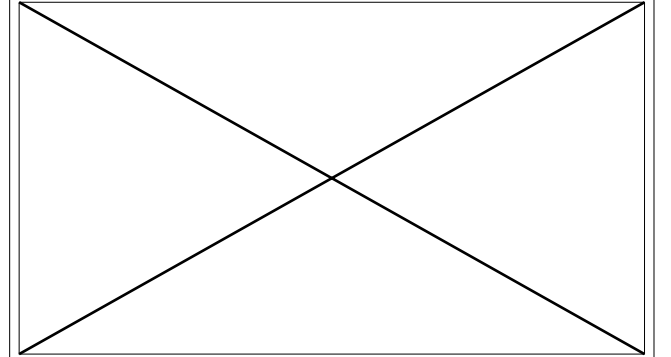

Dialogue
 PICK UP LAPINET
 arf! arf! arf!

Dialogue
 SFX high five

| Scene | Duration | Panel | Duration |
|-------|----------|-------|----------|
| 4 | 04:07 | 4 | 01:00 |

| Scene | Duration | Panel | Duration |
|-------|----------|-------|----------|
| 4 | 04:07 | 5 | 00:19 |

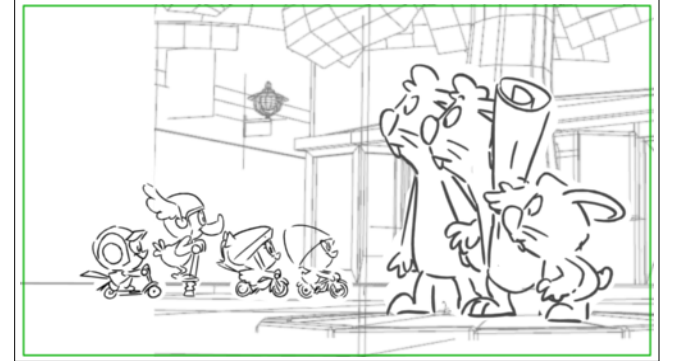
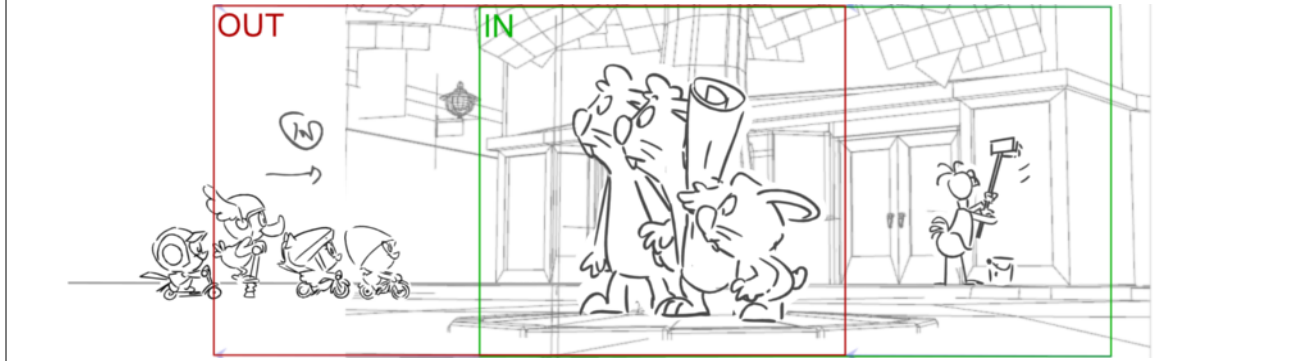

Dialogue
 SFX TRING TRING (KLAXON de VELO)

Action Notes
 CALIMERO PRISC PIERROT VALERIANO IN

| Scene | Duration | Panel | Duration |
|-------|----------|-------|----------|
| 5 | 01:04 | 1 | 00:11 |

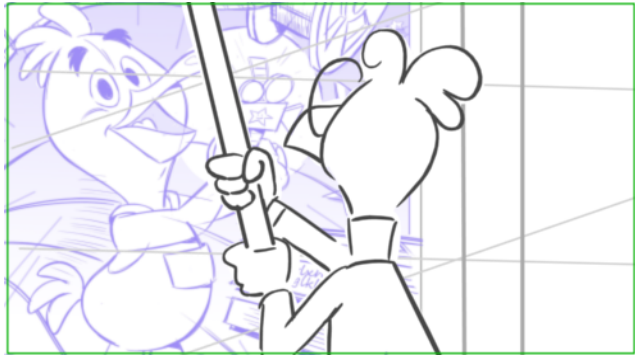

| Scene | Duration | Panel | Duration |
|-------|----------|-------|----------|
| 5 | 01:04 | 2 | 00:18 |

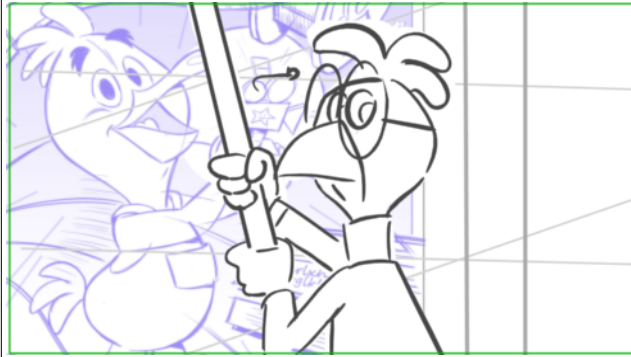

| Scene | Duration | Panel | Duration |
|-------|----------|-------|----------|
| 6 | 05:07 | 1 | 00:10 |

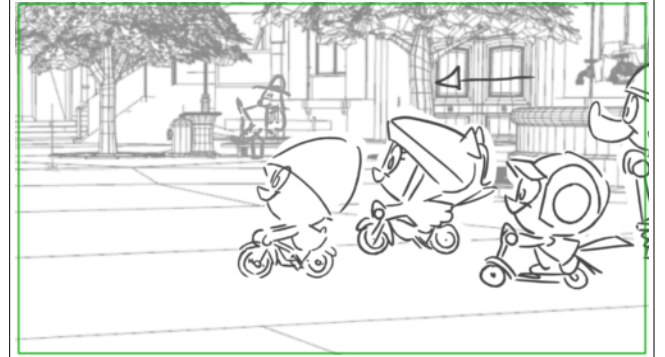

Dialogue

1. MR KINOS (ronchonnant)
Ah Tiens!

| Scene | Duration | Panel | Duration |
|-------|----------|-------|----------|
| 6 | 05:07 | 2 | 00:22 |

| Scene | Duration | Panel | Duration |
|-------|----------|-------|----------|
| 6 | 05:07 | 3 | 01:13 |

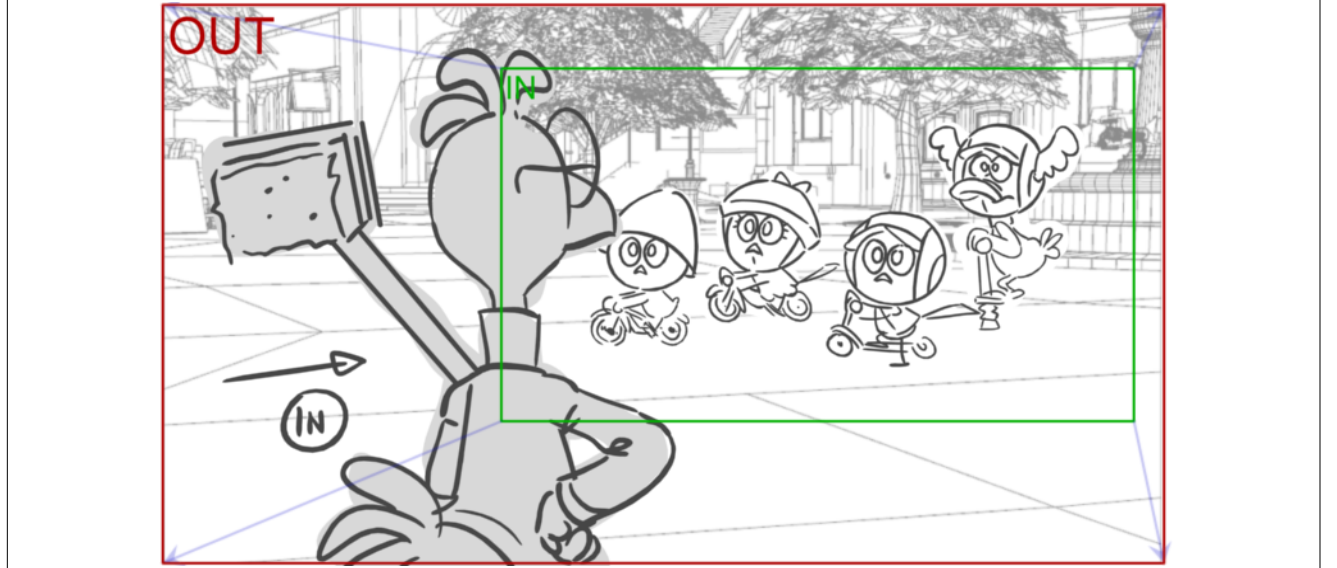
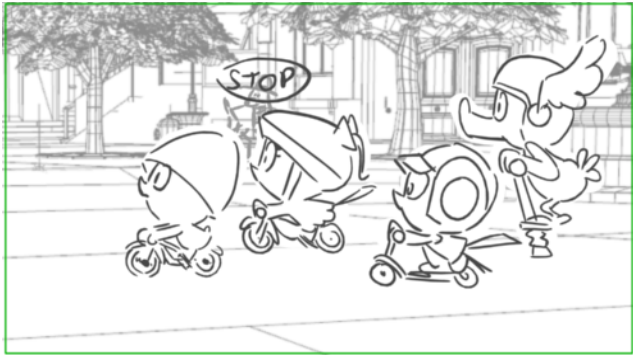

Dialogue

1. MR KINOS (ronchonnant)
J'attends encore ton film Valeriano!

| Scene | Duration | Panel | Duration |
|-------|----------|-------|----------|
| 6 | 05:07 | 4 | 00:19 |

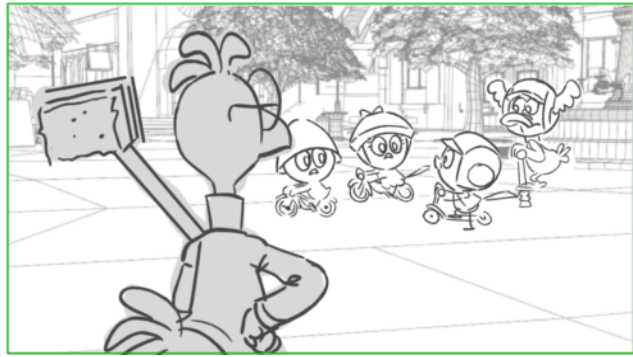

Action Notes

les enfants se regardent perplexes

| Scene | Duration | Panel | Duration |
|-------|----------|-------|----------|
| 6 | 05:07 | 5 | 01:18 |

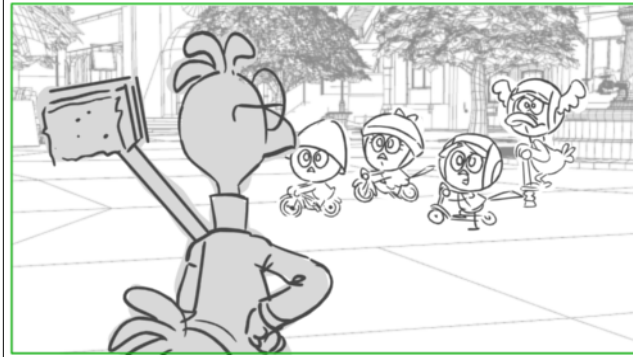

Dialogue

2. VALERIANO (tout excité, grand sourire béat)
 Quel film, M'sieur Kinos ?!

| Scene | Duration | Panel | Duration |
|-------|----------|-------|----------|
| 7 | 03:02 | 1 | 00:14 |



| Scene | Duration | Panel | Duration |
|-------|----------|-------|----------|
| 7 | 03:02 | 2 | 02:13 |

| Scene | Duration | Panel | Duration |
|-------|----------|-------|----------|
| 8 | 01:11 | 1 | 00:04 |

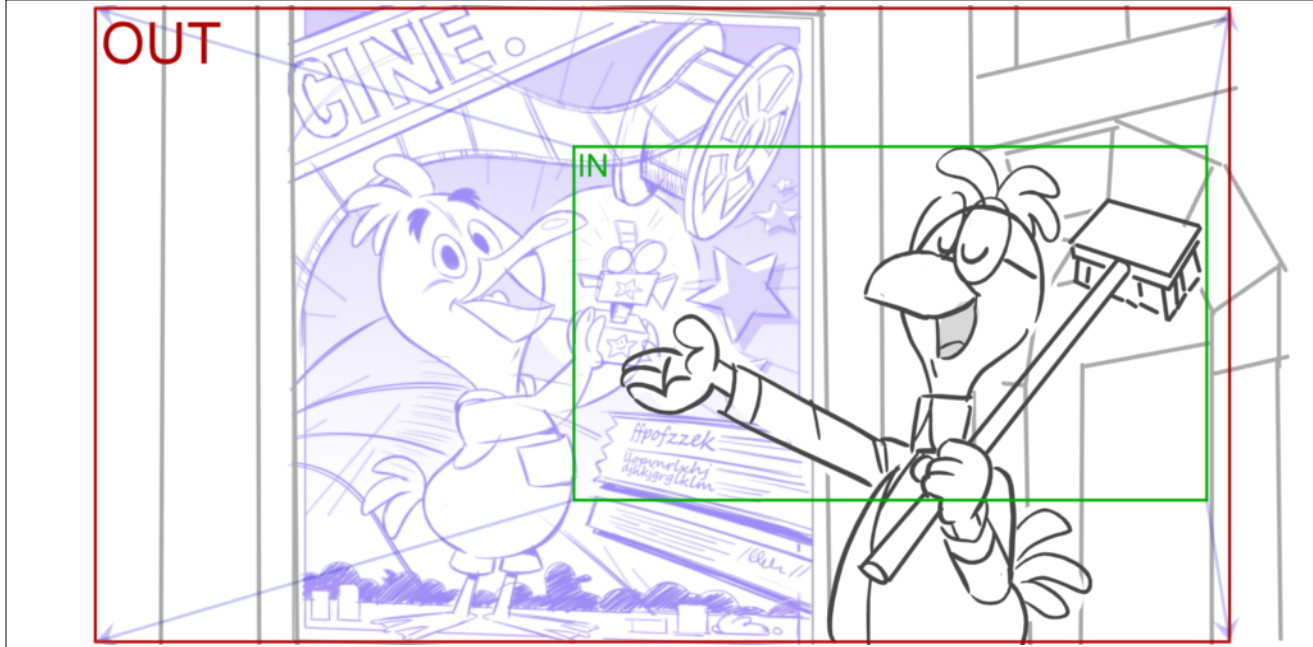

Dialogue

3. MR KINOS (sur le ton de l'évidence)
 Celui pour le concours du « Meilleur petit cinéaste » !

| Scene | Duration | Panel | Duration |
|-------|----------|-------|----------|
| 8 | 01:11 | 2 | 00:02 |



| Scene | Duration | Panel | Duration |
|-------|----------|-------|----------|
| 8 | 01:11 | 3 | 00:05 |



| Scene | Duration | Panel | Duration |
|-------|----------|-------|----------|
| 8 | 01:11 | 4 | 01:00 |

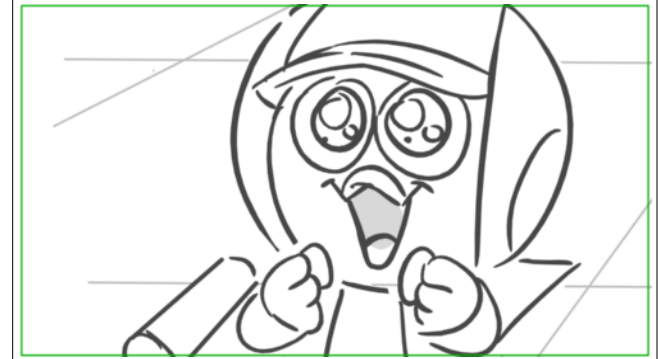

Dialogue

PICK UP VALERIANO
Whaou!

Action Notes

VALERIANO a des étoiles dans les yeux

| Scene | Duration | Panel | Duration |
|-------|----------|-------|----------|
| 9 | 05:21 | 1 | 01:00 |



Dialogue

PICK UP VALERIANO
un concours de films?

| Scene | Duration | Panel | Duration |
|-------|----------|-------|----------|
| 9 | 05:21 | 2 | 01:00 |



Dialogue

PICK UP VALERIANO
Ca alors!

| Scene | Duration | Panel | Duration |
|-------|----------|-------|----------|
| 9 | 05:21 | 3 | 02:03 |



Dialogue

3. MR KINOS (sur le ton de l'évidence)
Le gagnant aura droit à dix places de
cinéma gratuites !

| Scene | Duration | Panel | Duration |
|-------|----------|-------|----------|
| 9 | 05:21 | 4 | 01:18 |

| Scene | Duration | Panel | Duration |
|-------|----------|-------|----------|
| 10 | 05:14 | 1 | 00:10 |

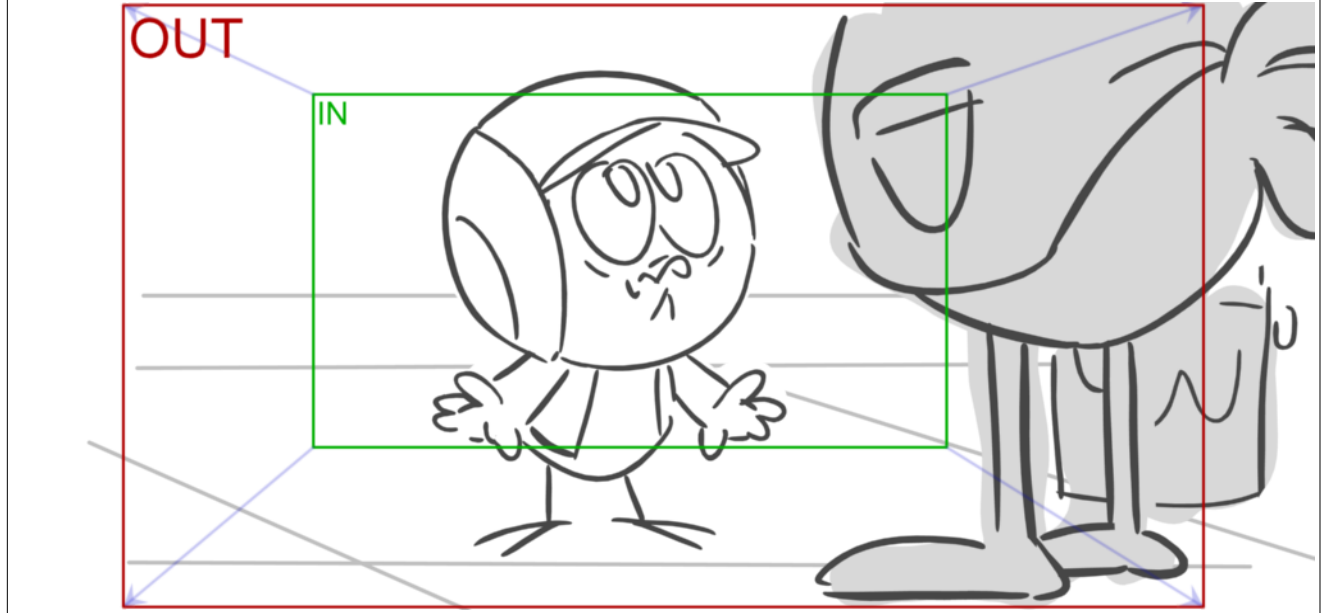
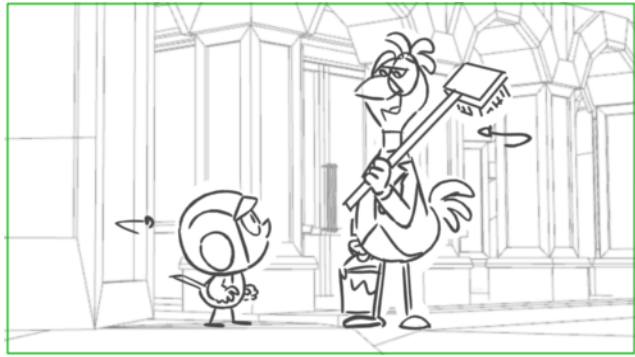

Dialogue
 3. MR KINOS (sur le ton de l'évidence)
 Le concours a lieu ce soir.

| Scene | Duration | Panel | Duration |
|-------|----------|-------|----------|
| 10 | 05:14 | 2 | 00:14 |

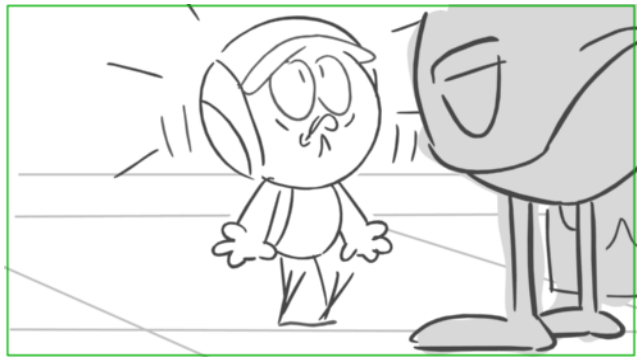

| Scene | Duration | Panel | Duration |
|-------|----------|-------|----------|
| 10 | 05:14 | 3 | 01:00 |

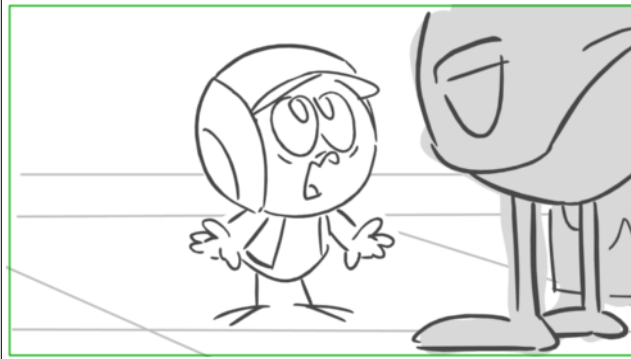

Dialogue
 4. VALERIANO (affolé)
 ?Ce soir ?!

| Scene | Duration | Panel | Duration |
|-------|----------|-------|----------|
| 10 | 05:14 | 4 | 00:15 |

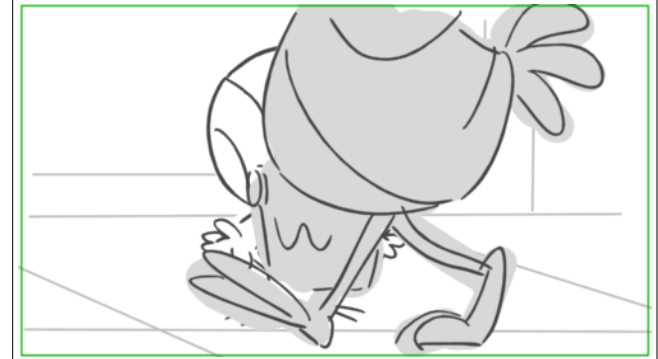

| Scene | Duration | Panel | Duration |
|-------|----------|-------|----------|
| 10 | 05:14 | 5 | 01:00 |

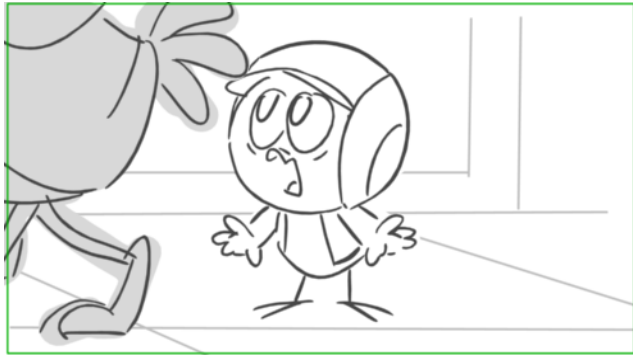

Dialogue
 4. VALERIANO (affolé)
 Mais !?

Action Notes
 MR KINOS OUT

| Scene | Duration | Panel | Duration |
|-------|----------|-------|----------|
| 10 | 05:14 | 6 | 01:00 |



Dialogue
 9. VALERIANO (dépité)
 Pfff?

| Scene | Duration | Panel | Duration |
|-------|----------|-------|----------|
| 10 | 05:14 | 7 | 01:00 |



Dialogue
 9. VALERIANO (dépité)
 C'est trop nul

| Scene | Duration | Panel | Duration |
|-------|----------|-------|----------|
| 11 | 08:02 | 1 | 00:11 |



| Scene | Duration | Panel | Duration |
|-------|----------|-------|----------|
| 11 | 08:02 | 2 | 01:01 |

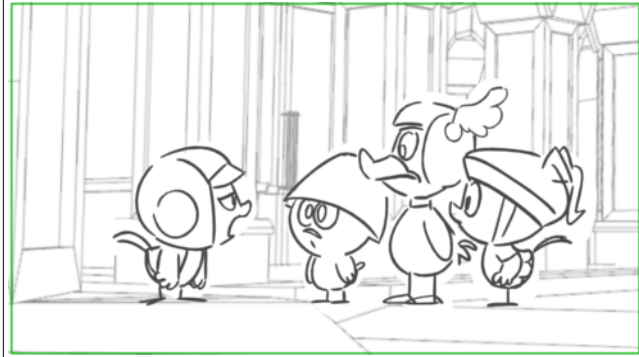

Dialogue

9. VALERIANO (dépité)
 J'aurais trop méga aimé faire ce concours !

| Scene | Duration | Panel | Duration |
|-------|----------|-------|----------|
| 11 | 08:02 | 3 | 02:02 |



Dialogue

9. VALERIANO (dépité)
 J'aurais trop méga aimé faire ce concours !

| Scene | Duration | Panel | Duration |
|-------|----------|-------|----------|
| 11 | 08:02 | 4 | 01:17 |

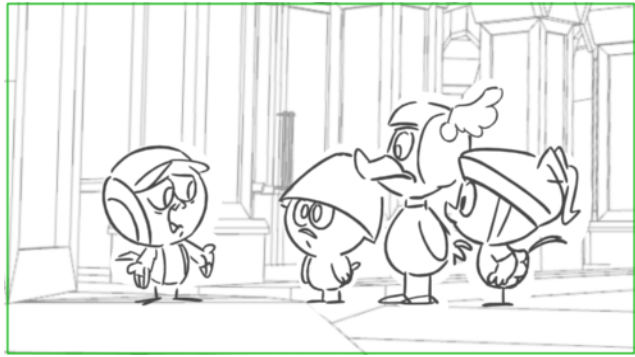

Dialogue

9. VALERIANO (dépité)
 Mais c'est impossible de faire un film
 avant ce soir?

| Scene | Duration | Panel | Duration |
|-------|----------|-------|----------|
| 11 | 08:02 | 5 | 01:11 |

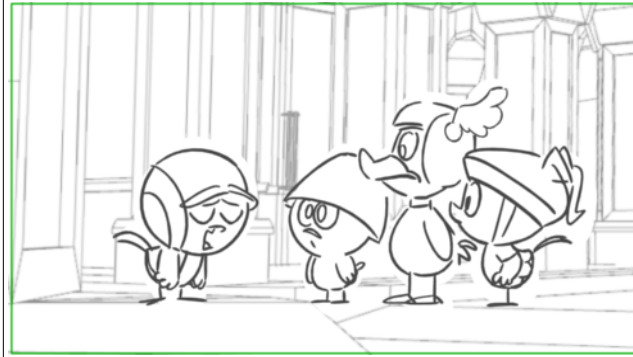

Dialogue

9. VALERIANO (dépité)
 Mais c'est impossible de faire un film
 avant ce soir?

| Scene | Duration | Panel | Duration |
|-------|----------|-------|----------|
| 11 | 08:02 | 6 | 00:15 |



Dialogue

5. POT
 Arf ! Arf ! Arf !

| Scene | Duration | Panel | Duration |
|-------|----------|-------|----------|
| 11 | 08:02 | 7 | 00:20 |

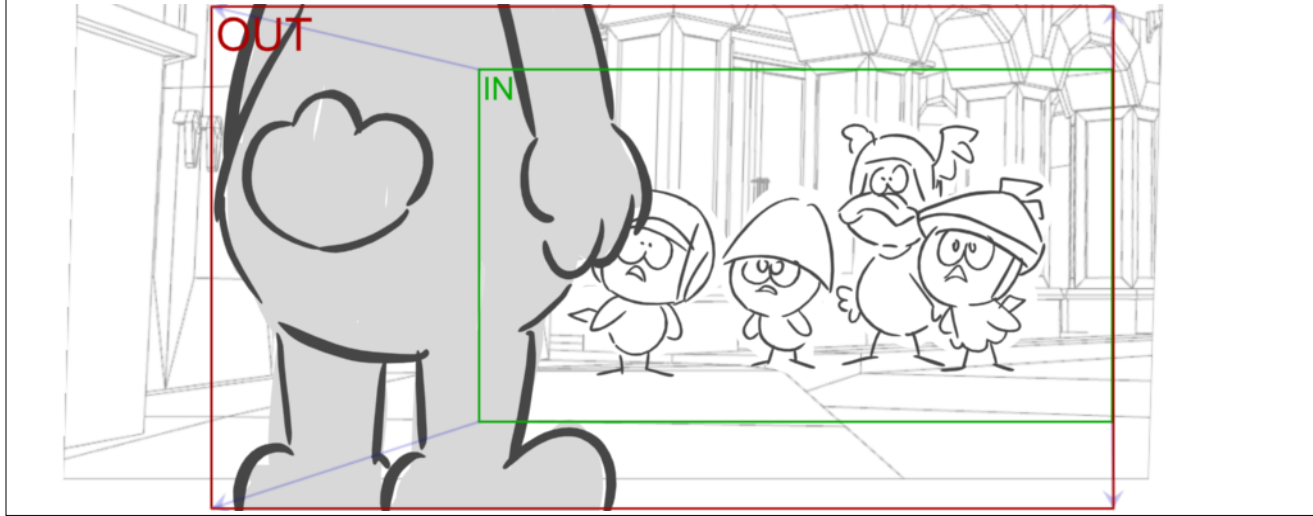

Action Notes
LAPIN IN

| Scene | Duration | Panel | Duration |
|-------|----------|-------|----------|
| 12 | 07:05 | 1 | 01:00 |



Dialogue

5. POT
Alors, la star de la caméra,

| Scene | Duration | Panel | Duration |
|-------|----------|-------|----------|
| 12 | 07:05 | 2 | 01:00 |



Dialogue

5. POT
t?as pas d?film à présenter ?

Action Notes

POT brandit un dvd

| Scene | Duration | Panel | Duration |
|-------|----------|-------|----------|
| 12 | 07:05 | 3 | 01:00 |



| Scene | Duration | Panel | Duration |
|-------|----------|-------|----------|
| 12 | 07:05 | 4 | 02:08 |



Dialogue

5. POT
Arf ! Arf ! Arf !

| Scene | Duration | Panel | Duration |
|-------|----------|-------|----------|
| 12 | 07:05 | 5 | 00:15 |



Dialogue

5. POT
Nous on a fini le nôtre !

| Scene | Duration | Panel | Duration |
|-------|----------|-------|----------|
| 12 | 07:05 | 6 | 01:07 |



Dialogue

5. POT
Nous on a déjà fini le nôtre !

| Scene | Duration | Panel | Duration |
|-------|----------|-------|----------|
| 13 | 03:07 | 1 | 00:24 |



Dialogue

6. VALERIANO (ne comprenant pas)
Mais!

| Scene | Duration | Panel | Duration |
|-------|----------|-------|----------|
| 13 | 03:07 | 2 | 02:08 |



Dialogue

6. PICK UP VALERIANO (ne comprenant pas)
 Comment vous étiez au courant du concours les Lapinet!

| Scene | Duration | Panel | Duration |
|-------|----------|-------|----------|
| 14 | 01:16 | 1 | 01:16 |

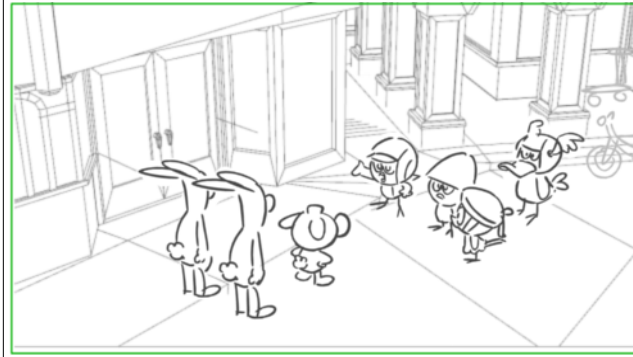

Dialogue

6. PICK UP VALERIANO (ne comprenant pas)
 J''l ai jamais vue moi cette affiche moi!

Action Notes

VALERIANO designe l'affiche

| Scene | Duration | Panel | Duration |
|-------|----------|-------|----------|
| 15 | 05:01 | 1 | 00:16 |

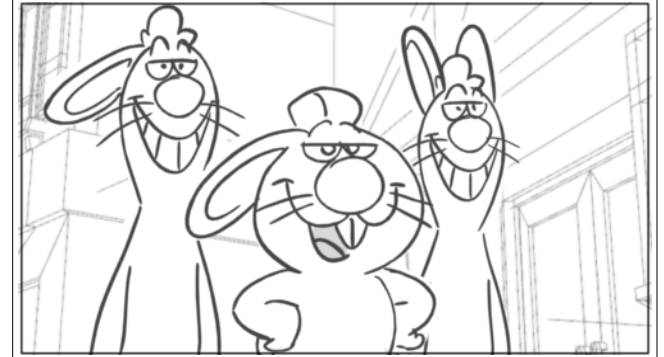

Dialogue

7. POT (feignant l?innocence)
 Aaah ?...

| Scene | Duration | Panel | Duration |
|-------|----------|-------|----------|
| 15 | 05:01 | 2 | 01:04 |



Dialogue

7. POT (feignant l'innocence)
c'est vraiment dommage,

| Scene | Duration | Panel | Duration |
|-------|----------|-------|----------|
| 15 | 05:01 | 3 | 01:14 |



Dialogue

7. POT (feignant l'innocence)
C'est nous qu'on va gagner les places
alors!

| Scene | Duration | Panel | Duration |
|-------|----------|-------|----------|
| 15 | 05:01 | 4 | 01:17 |



Dialogue

8. POT (repris par COT et MOT)
Arf ! Arf ! Arf !

| Scene | Duration | Panel | Duration |
|-------|----------|-------|----------|
| 16 | 08:19 | 1 | 00:16 |

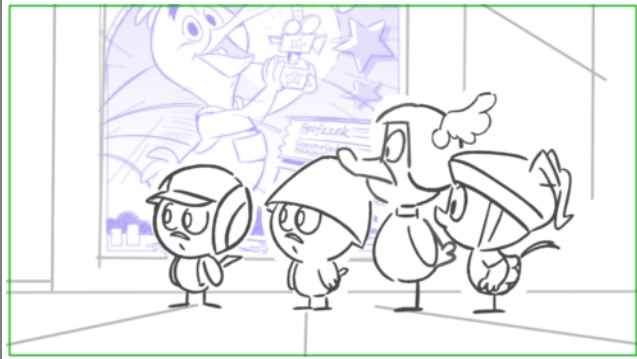

| Scene | Duration | Panel | Duration |
|-------|----------|-------|----------|
| 16 | 08:19 | 2 | 00:17 |

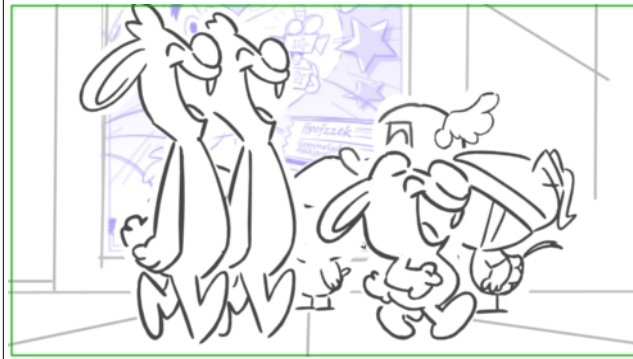

Dialogue

8. POT (repris par COT et MOT)
Arf ! Arf ! Arf !

| Scene | Duration | Panel | Duration |
|-------|----------|-------|----------|
| 16 | 08:19 | 3 | 00:17 |

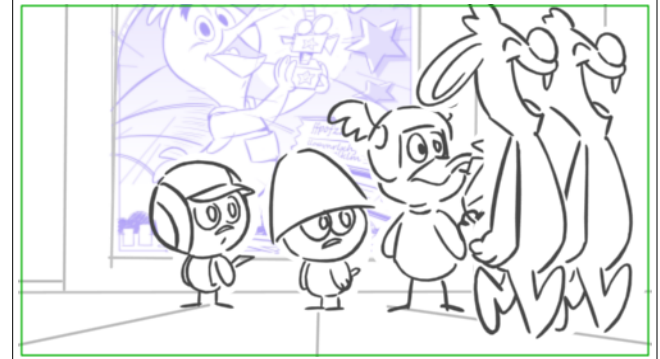

Dialogue

8. POT (repris par COT et MOT)
Arf ! Arf ! Arf !

| Scene | Duration | Panel | Duration |
|-------|----------|-------|----------|
| 16 | 08:19 | 4 | 00:16 |

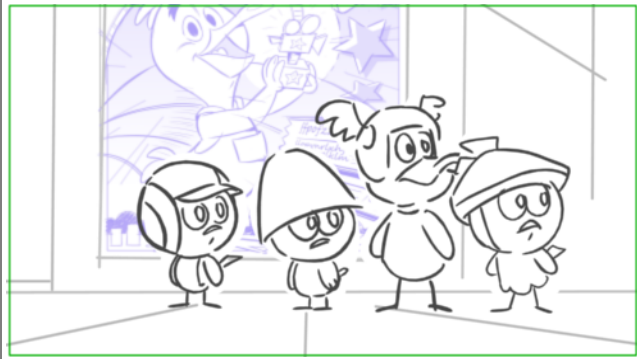

Dialogue

8. POT (repris par COT et MOT)
Arf ! Arf ! Arf !

| Scene | Duration | Panel | Duration |
|-------|----------|-------|----------|
| 16 | 08:19 | 5 | 00:19 |

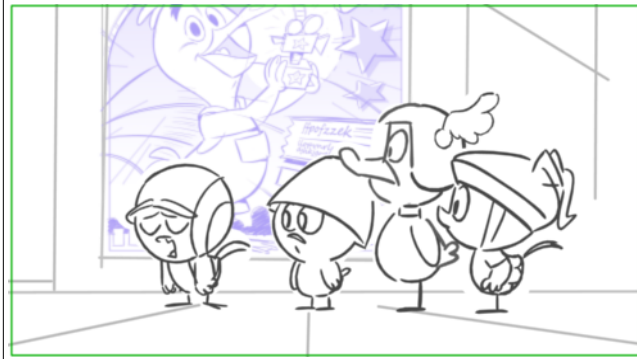

Dialogue

9. VALERIANO (dépité)
Pfff? C'est trop nul?

| Scene | Duration | Panel | Duration |
|-------|----------|-------|----------|
| 16 | 08:19 | 6 | 01:12 |

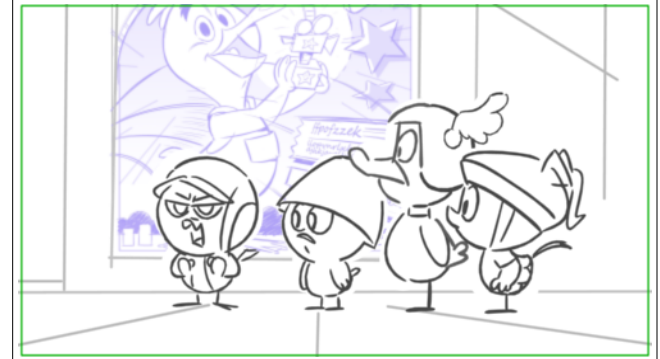

Dialogue

9. VALERIANO (dépité)
Pfff? C'est trop nul?

| Scene | Duration | Panel | Duration |
|-------|----------|-------|----------|
| 16 | 08:19 | 7 | 01:02 |



Action Notes

CALIMERO regarde les autres

| Scene | Duration | Panel | Duration |
|-------|----------|-------|----------|
| 16 | 08:19 | 8 | 01:01 |

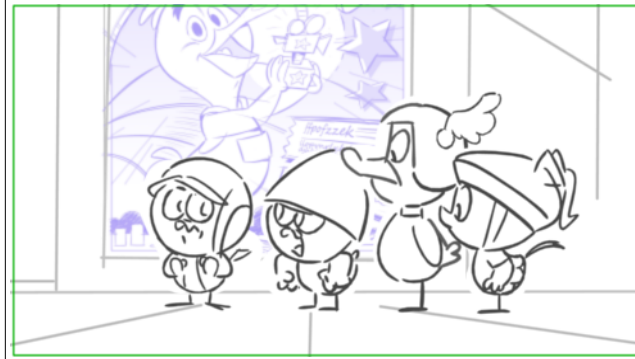

Dialogue

PICK UP CALIMERO
C'est vraiment trop injuste!

| Scene | Duration | Panel | Duration |
|-------|----------|-------|----------|
| 16 | 08:19 | 9 | 00:22 |



Dialogue

PICK UP CALIMERO
C'est vraiment trop injuste!

| Scene | Duration | Panel | Duration |
|-------|----------|-------|----------|
| 16 | 08:19 | 10 | 00:22 |

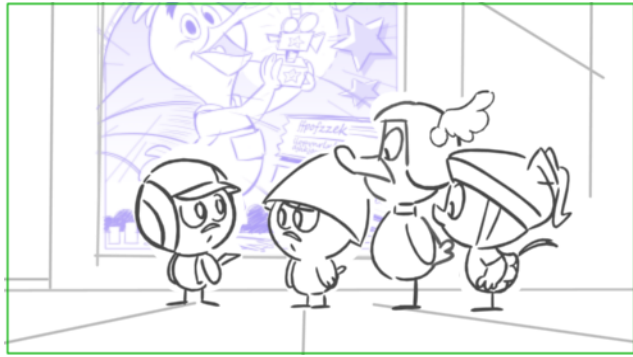

Dialogue
 PICK UP CALIMERO
 C'est vraiment trop injuste!

| Scene | Duration | Panel | Duration |
|-------|----------|-------|----------|
| 17 | 02:18 | 1 | 00:10 |

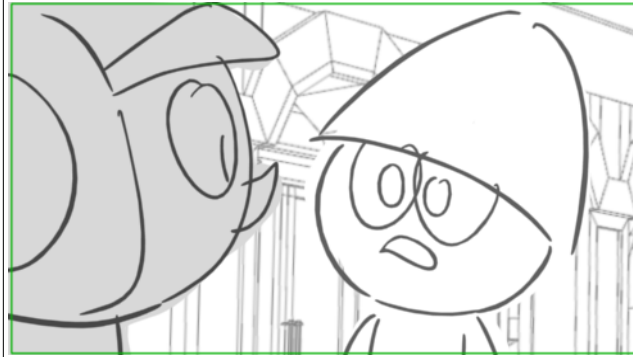

Dialogue
 9. VALERIANO (dépité)

| Scene | Duration | Panel | Duration |
|-------|----------|-------|----------|
| 17 | 02:18 | 2 | 02:08 |

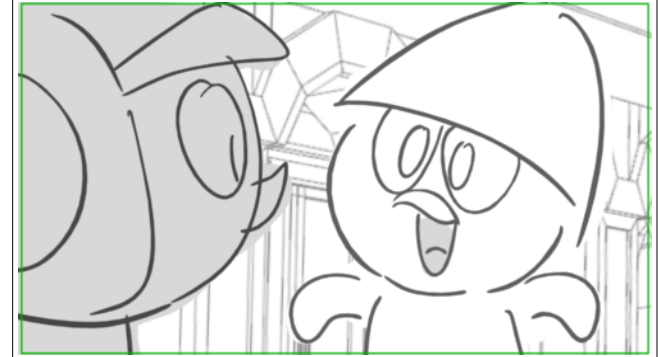

Dialogue
 10. CALIMERO (indigné)
 Tu peux compter sur nous Valériano !

| Scene | Duration | Panel | Duration |
|-------|----------|-------|----------|
| 18 | 09:05 | 1 | 01:08 |

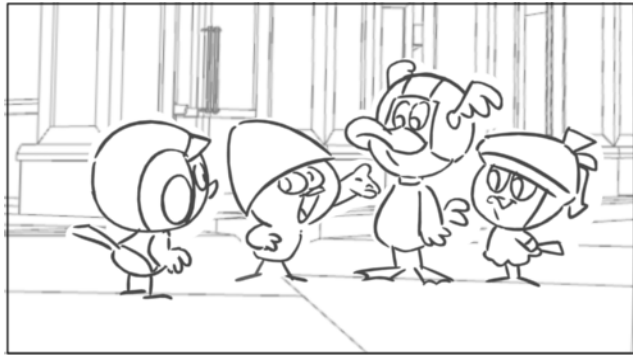

Dialogue

10. CALIMERO (indigné)
Avec Priscilla et Pierrot,

| Scene | Duration | Panel | Duration |
|-------|----------|-------|----------|
| 18 | 09:05 | 2 | 01:23 |

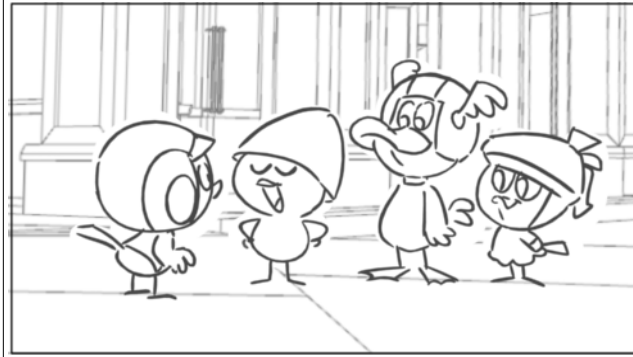

Dialogue

10. CALIMERO (indigné)
on va t'aider à en faire un, de film.

| Scene | Duration | Panel | Duration |
|-------|----------|-------|----------|
| 18 | 09:05 | 3 | 02:00 |

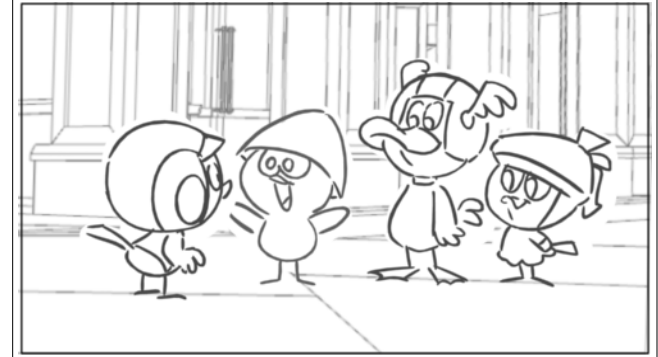

Dialogue

10. CALIMERO (indigné)
Et ce sera un chef-d'œuvre !

| Scene | Duration | Panel | Duration |
|-------|----------|-------|----------|
| 18 | 09:05 | 4 | 01:00 |

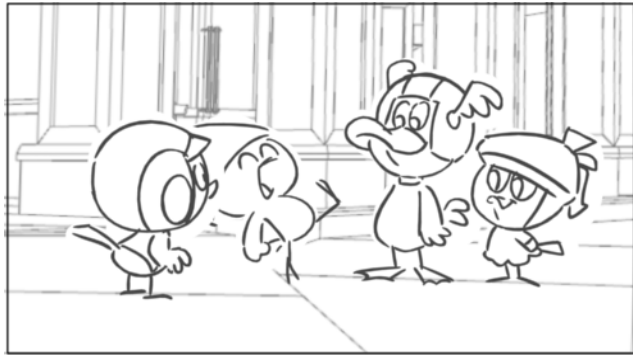

Dialogue
 11. CALIMERO
 Parole de poussins !...

| Scene | Duration | Panel | Duration |
|-------|----------|-------|----------|
| 18 | 09:05 | 5 | 00:13 |

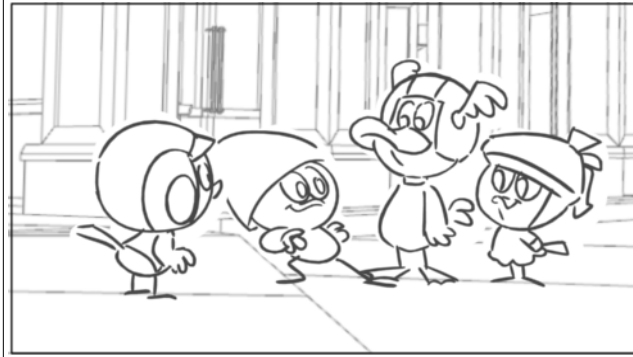

| Scene | Duration | Panel | Duration |
|-------|----------|-------|----------|
| 18 | 09:05 | 6 | 01:00 |

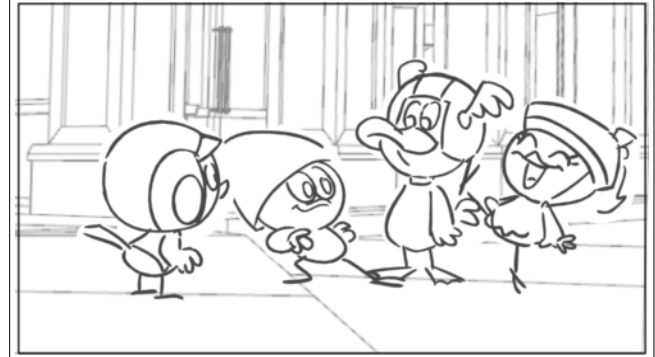

Dialogue
 11. PRISCILLA
 Parole de poussins !...

| Scene | Duration | Panel | Duration |
|-------|----------|-------|----------|
| 18 | 09:05 | 7 | 01:00 |

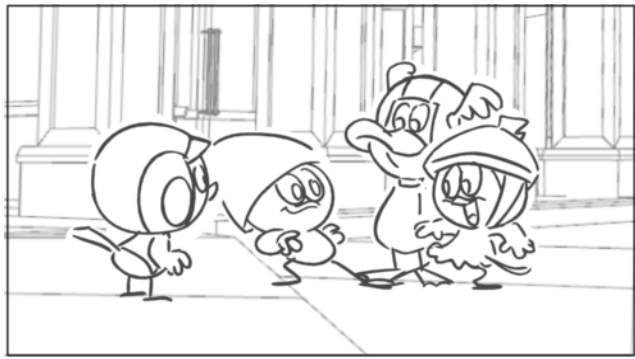

Action Notes
REUT ANIM

| Scene | Duration | Panel | Duration |
|-------|----------|-------|----------|
| 18 | 09:05 | 8 | 00:11 |

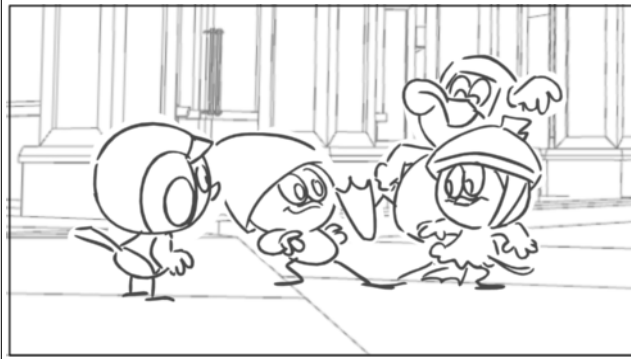

| Scene | Duration | Panel | Duration |
|-------|----------|-------|----------|
| 19 | 01:01 | 1 | 00:08 |

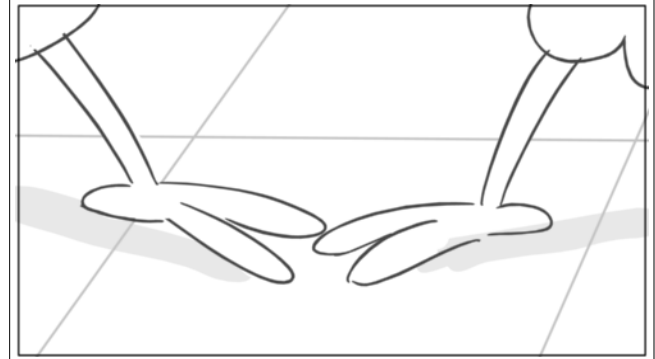

Dialogue
12. PIERROT
?Et foi de canard !

Action Notes
REUT ANIM



| Scene | Duration | Panel | Duration |
|-------|----------|-------|----------|
| 19 | 01:01 | 2 | 00:18 |

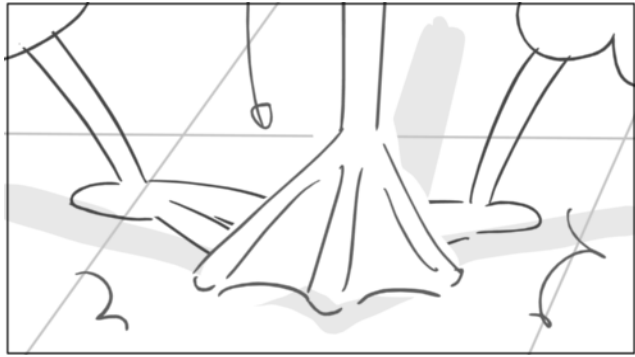

| Scene | Duration | Panel | Duration |
|-------|----------|-------|----------|
| 20 | 01:17 | 1 | 01:17 |

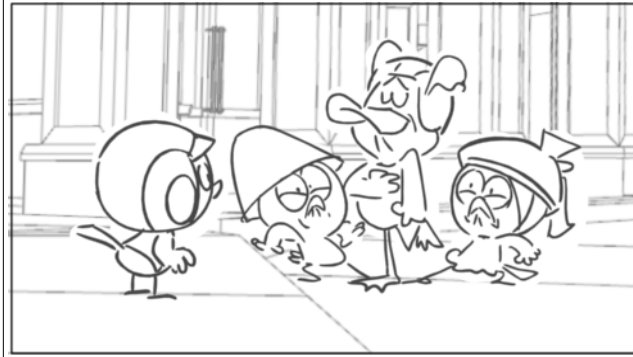

NO PANEL

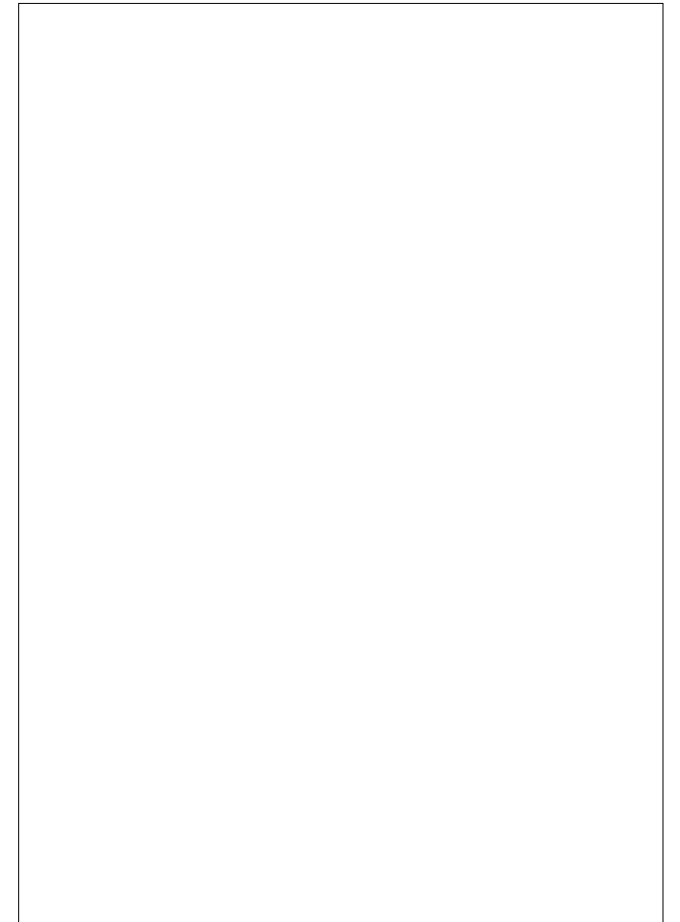
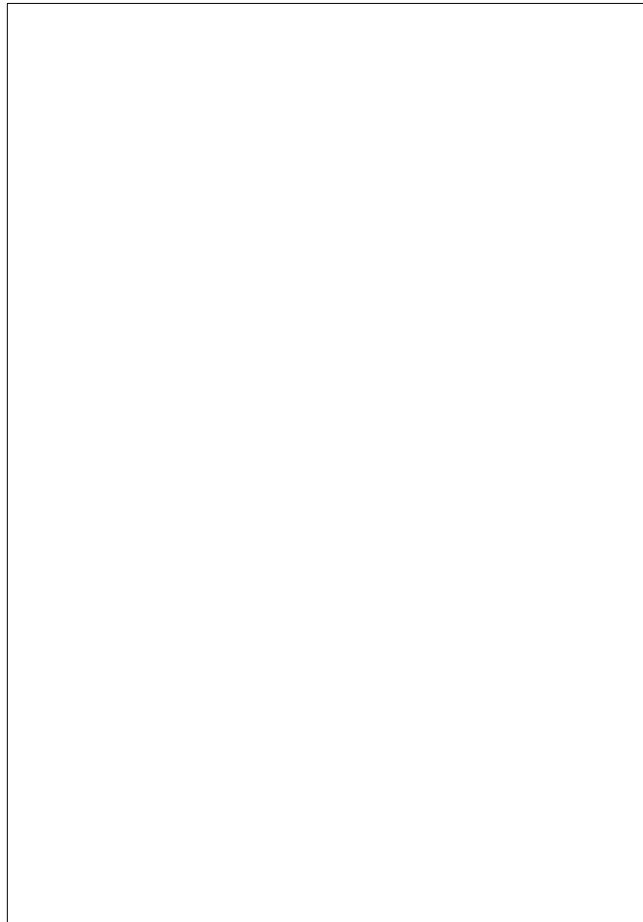
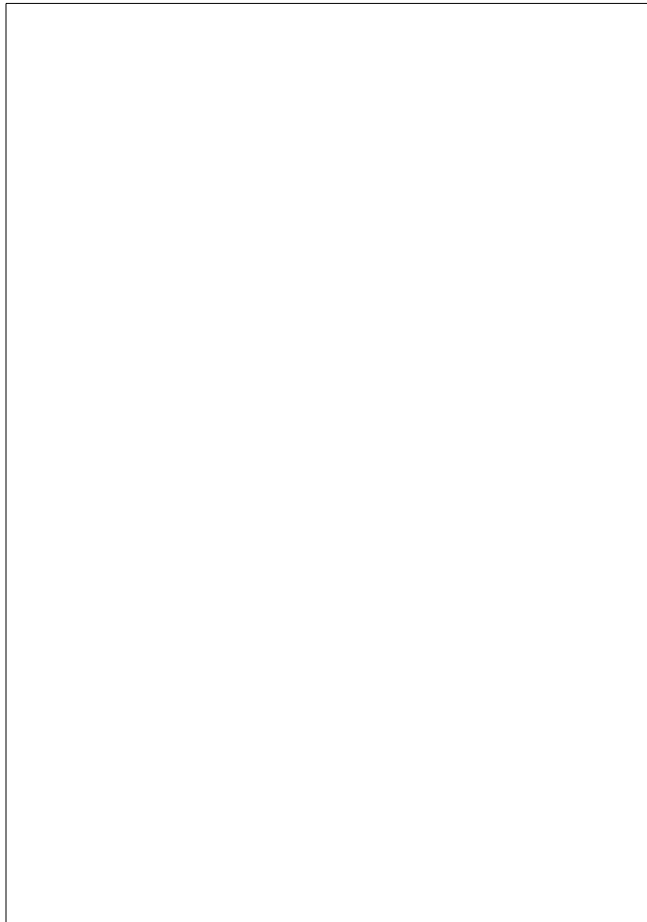
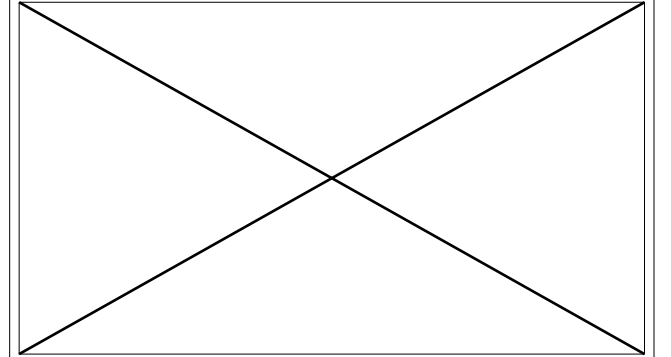



| | | | |
|-------|----------|-------|----------|
| Scene | Duration | Panel | Duration |
| 21 | 02:00 | 1 | 00:14 |

NO PANEL

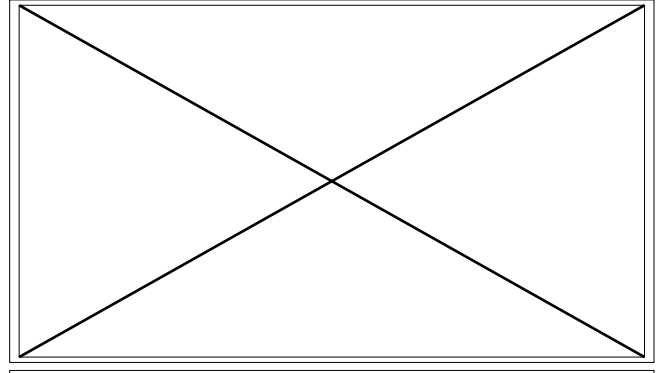
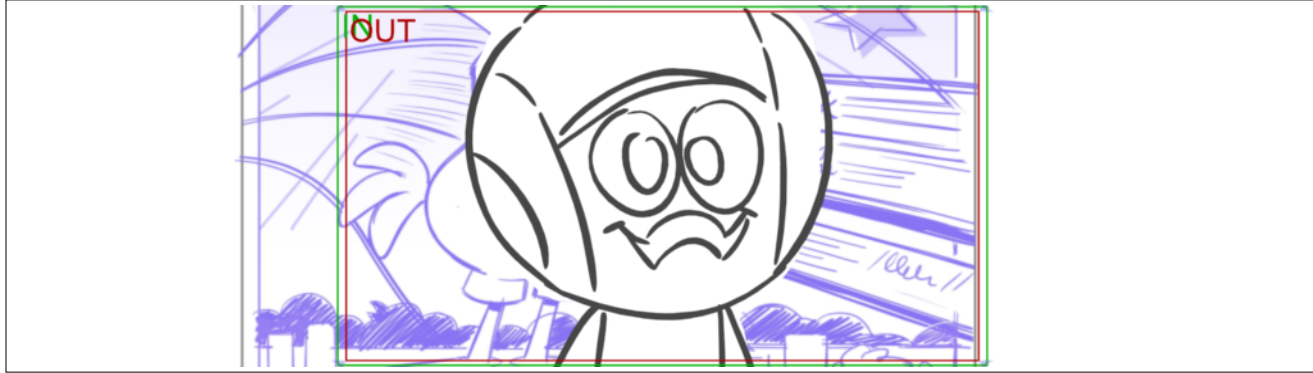

Action Notes

Sourire de Valériano reprenant espoir.

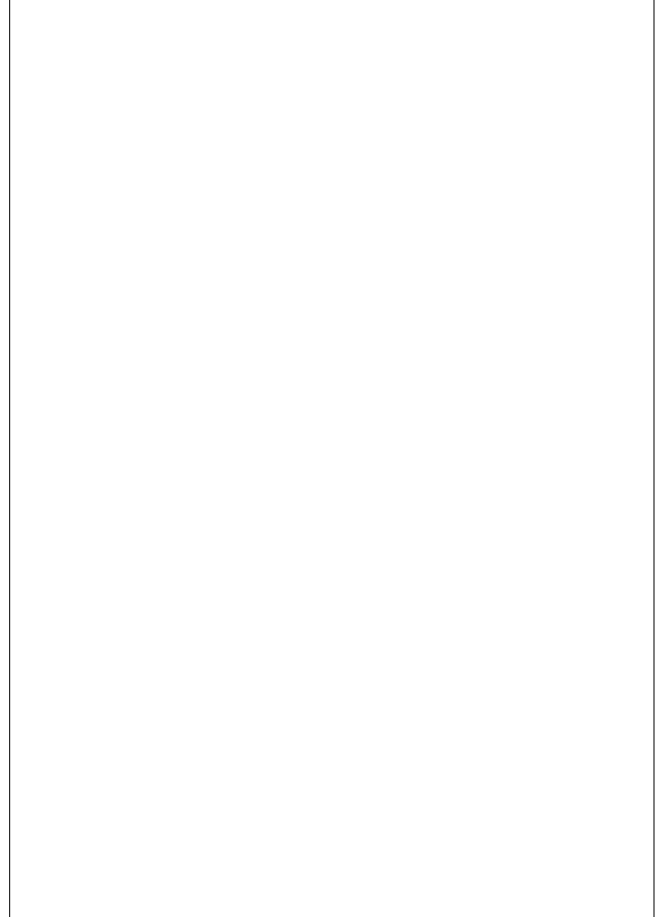



| Scene | Duration | Panel | Duration |
|-------|----------|-------|----------|
| 21 | 02:00 | 2 | 01:11 |

| Scene | Duration | Panel | Duration |
|-------|----------|-------|----------|
| 22 | 00:14 | 1 | 00:04 |

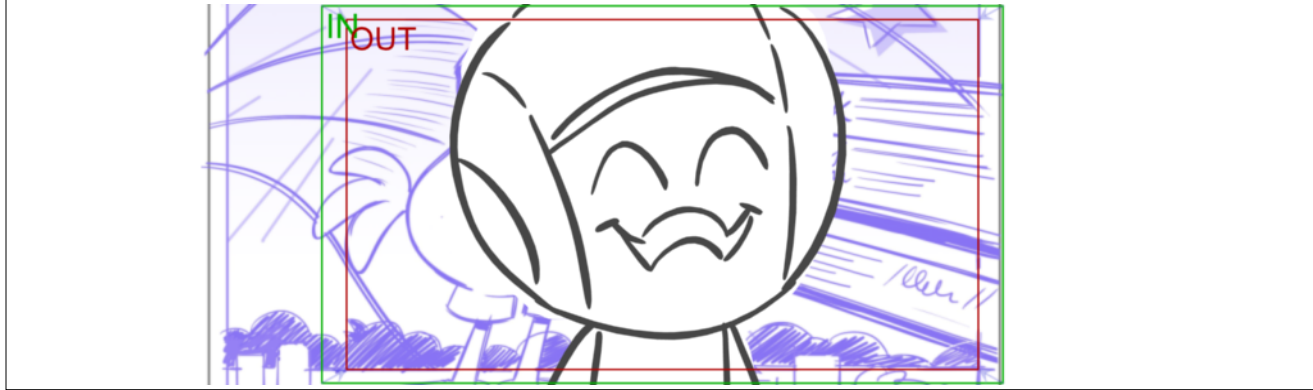

Action Notes

Sourire de Valériano reprenant espoir.

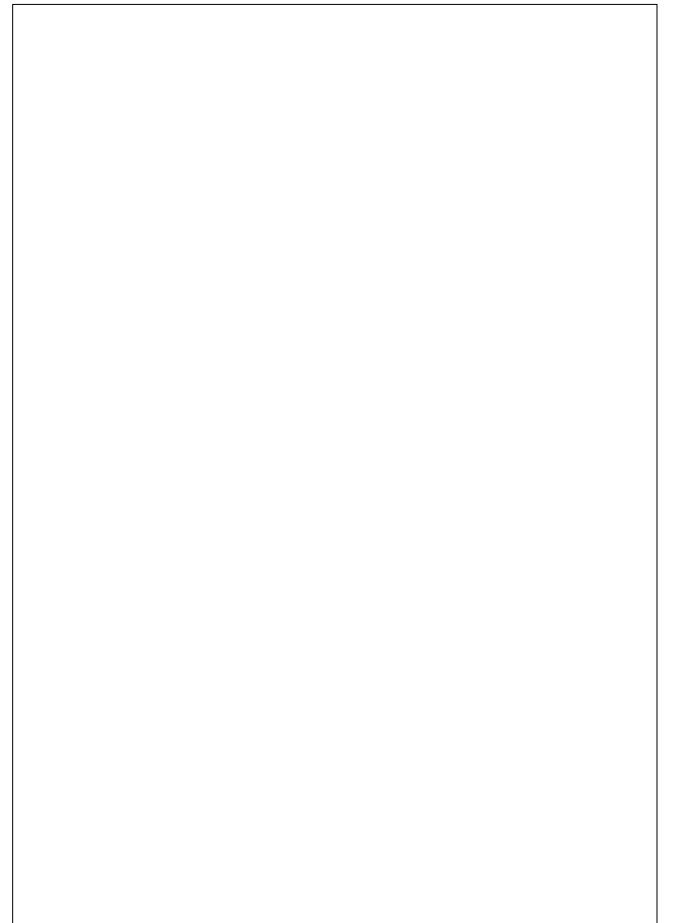

| Scene | Duration | Panel | Duration |
|-------|----------|-------|----------|
| 22 | 00:14 | 2 | 00:10 |

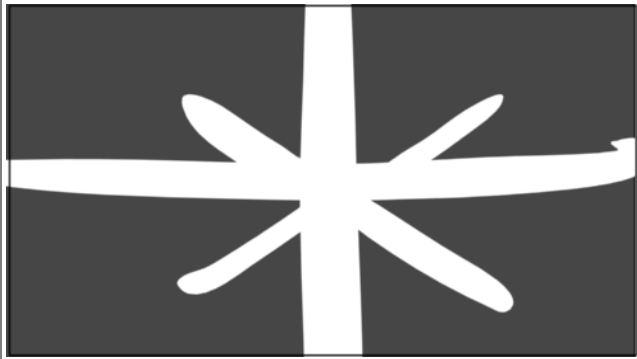

| Scene | Duration | Panel | Duration |
|-------|----------|-------|----------|
| 23 | 12:08 | 1 | 00:15 |

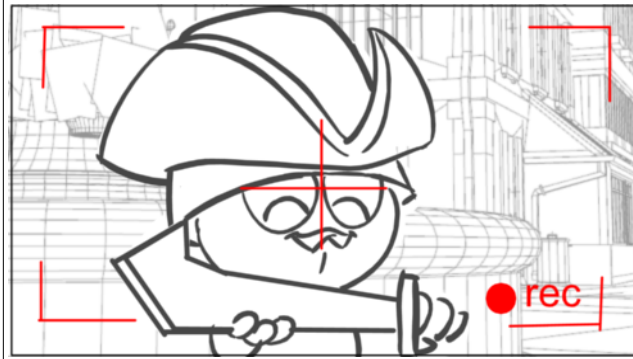

Dialogue

13. VALERIANO
 Alors, Caliméro sera « Coquillard,
 l'intrépide », le courageux Capitaine
 chargé de délivrer...

Slugging

3. PLACE BASSE ? PRES DE LA FONTAINE /
 EXT. JOUR
 Vue dans le viseur d'une caméra : Mise
 au point

| Scene | Duration | Panel | Duration |
|-------|----------|-------|----------|
| 23 | 12:08 | 2 | 01:14 |

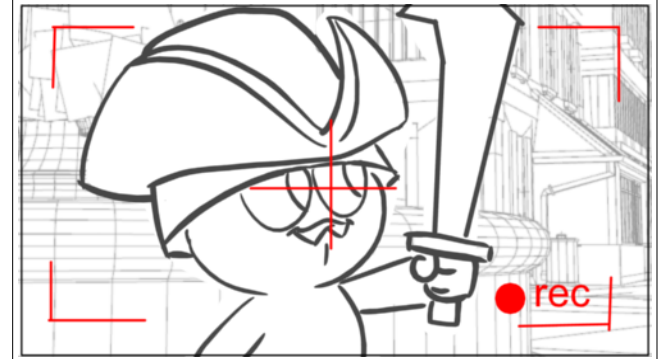

Dialogue

13. VALERIANO
 Alors, Caliméro sera « Coquillard,
 l'intrépide », le courageux Capitaine
 chargé de délivrer...

Action Notes

CALIMERO coiffé d'un tricorne brandit
 un sabre factice

| Scene | Duration | Panel | Duration |
|-------|----------|-------|----------|
| 23 | 12:08 | 3 | 00:16 |

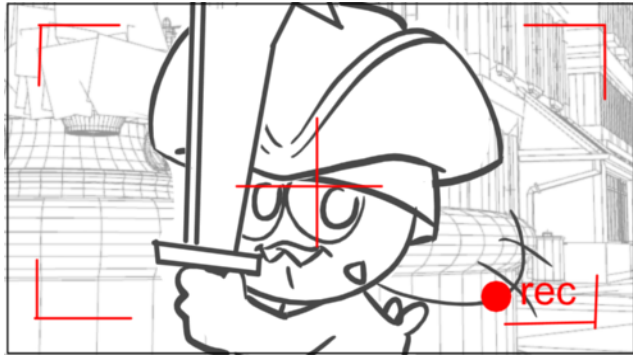

Dialogue

13. VALERIANO
Alors, Caliméro sera « Coquillard, l'intrépide », le courageux Capitaine chargé de délivrer...

| Scene | Duration | Panel | Duration |
|-------|----------|-------|----------|
| 23 | 12:08 | 4 | 00:22 |

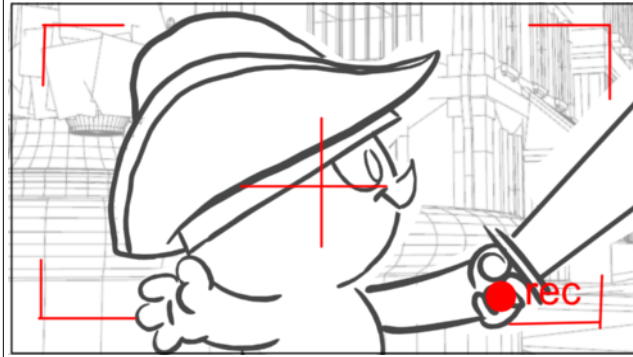

Dialogue

13. VALERIANO
Alors, Caliméro sera « Coquillard, l'intrépide », le courageux Capitaine chargé de délivrer...

| Scene | Duration | Panel | Duration |
|-------|----------|-------|----------|
| 23 | 12:08 | 5 | 01:02 |



Dialogue

13. VALERIANO
Alors, Caliméro sera « Coquillard, l'intrépide », le courageux Capitaine chargé de délivrer...

| Scene | Duration | Panel | Duration |
|-------|----------|-------|----------|
| 23 | 12:08 | 6 | 00:08 |

| Scene | Duration | Panel | Duration |
|-------|----------|-------|----------|
| 23 | 12:08 | 7 | 00:19 |

| Scene | Duration | Panel | Duration |
|-------|----------|-------|----------|
| 23 | 12:08 | 8 | 01:10 |

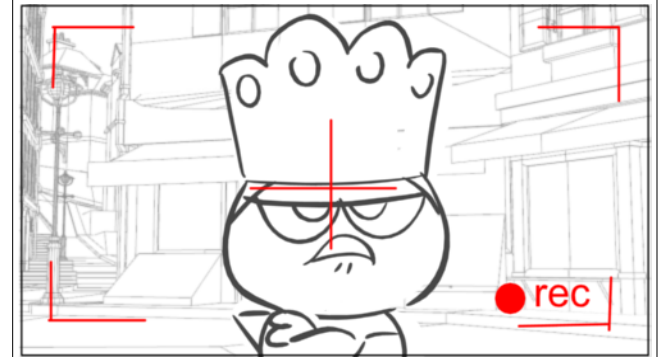
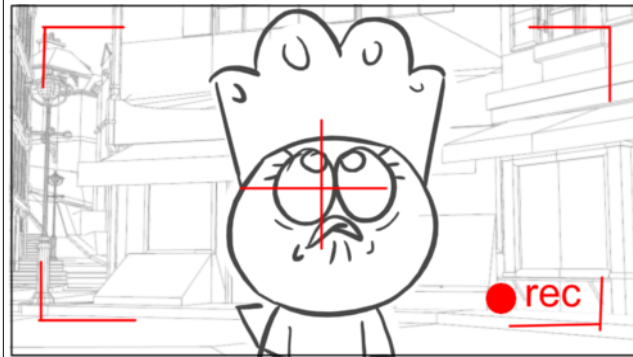
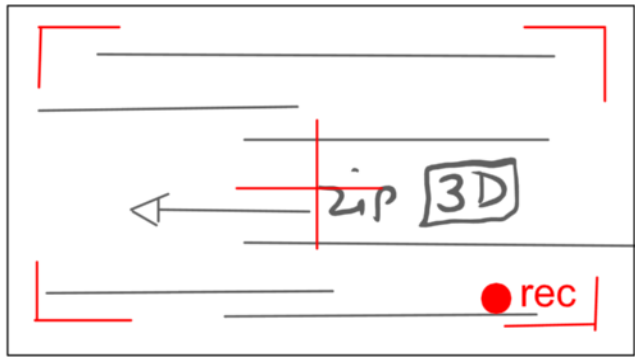

Dialogue

13. VALERIANO
 ...Priscilla, la princesse en
 détresse, enlevée par...

Dialogue

13. VALERIANO
 ...Priscilla, la princesse en
 détresse, enlevée par...

Action Notes

Priscilla (portant une couronne)

Action Notes

fait la moue

| Scene | Duration | Panel | Duration |
|-------|----------|-------|----------|
| 23 | 12:08 | 9 | 00:08 |

| Scene | Duration | Panel | Duration |
|-------|----------|-------|----------|
| 23 | 12:08 | 10 | 00:16 |

| Scene | Duration | Panel | Duration |
|-------|----------|-------|----------|
| 23 | 12:08 | 11 | 00:16 |

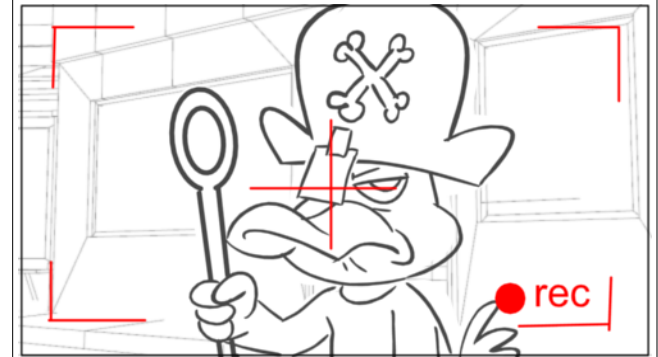
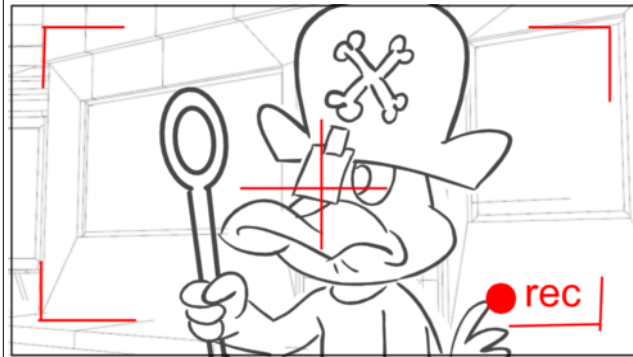
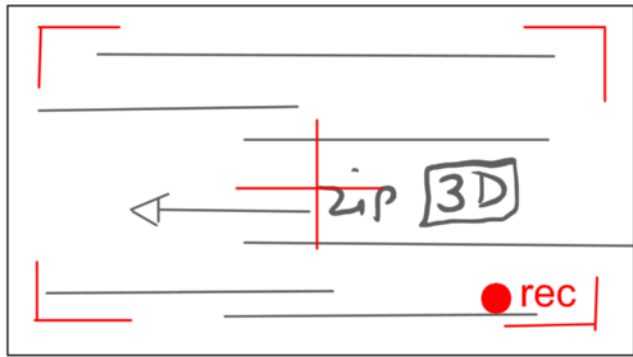

Dialogue

13. VALERIANO MODIF
 « Pierrot le borgne », le terrible
 pirate des mers du Sud.

Dialogue

13. VALERIANO MODIF
 « Pierrot le borgne », le terrible
 pirate des mers du Sud.

Action Notes

Pierrot (avec un chapeau pirate et une
 cuillère en guise d'arme

| Scene | Duration | Panel | Duration |
|-------|----------|-------|----------|
| 23 | 12:08 | 12 | 00:17 |

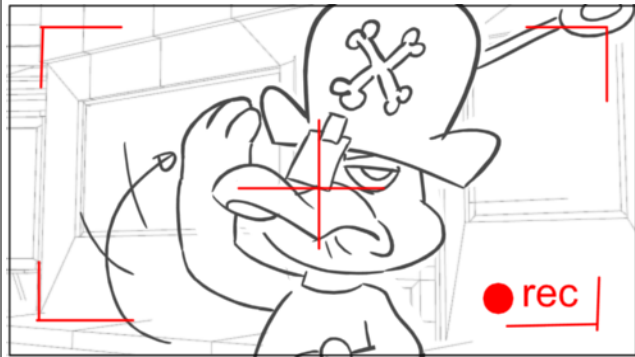

Dialogue

13. VALERIANO MODIF
« Pierrot le borgne », le terrible pirate des mers du Sud.

| Scene | Duration | Panel | Duration |
|-------|----------|-------|----------|
| 23 | 12:08 | 13 | 01:12 |

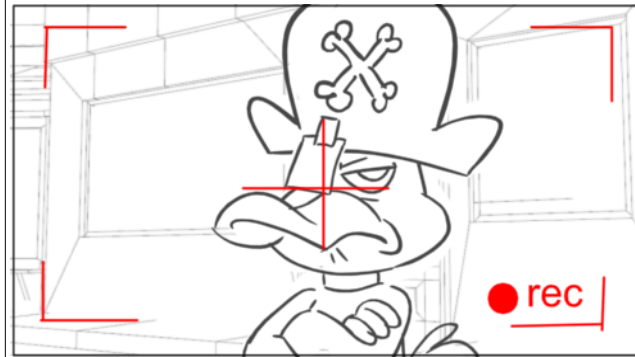

Dialogue

13. VALERIANO MODIF
« Pierrot le borgne », le terrible pirate des mers du Sud.

| Scene | Duration | Panel | Duration |
|-------|----------|-------|----------|
| 23 | 12:08 | 14 | 01:08 |



Dialogue

14. PIERROT (ôtant son chapeau de pirate)
Peuh !

| Scene | Duration | Panel | Duration |
|-------|----------|-------|----------|
| 24 | 07:24 | 1 | 02:06 |

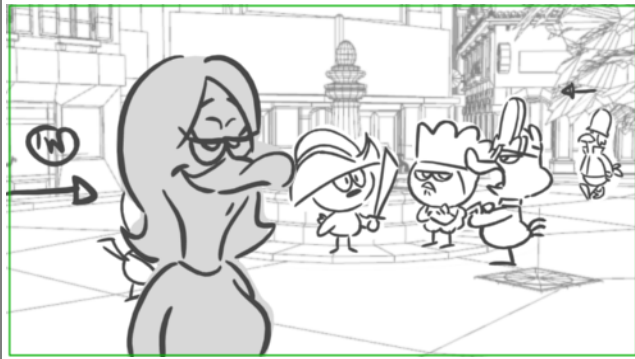

Dialogue

14. PIERROT (ôtant son chapeau de pirate)
Pourquoi c'est toujours moi le méchant, d'abord ?

| Scene | Duration | Panel | Duration |
|-------|----------|-------|----------|
| 24 | 07:24 | 2 | 03:08 |

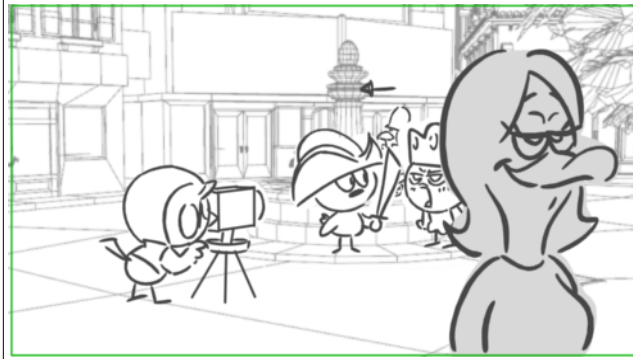

Dialogue

15. PRISCILLA (surenchérit en ôtant sa couronne)
Et pourquoi c'est toujours les filles qui sont les princesses en détresse ?

| Scene | Duration | Panel | Duration |
|-------|----------|-------|----------|
| 24 | 07:24 | 3 | 00:11 |



Dialogue

15. PRISCILLA (surenchérit en ôtant sa couronne)
Moi aussi, je veux jouer avec un sabre !

Action Notes

Priscilla prend le sabre de calimero

| Scene | Duration | Panel | Duration |
|-------|----------|-------|----------|
| 24 | 07:24 | 4 | 00:11 |

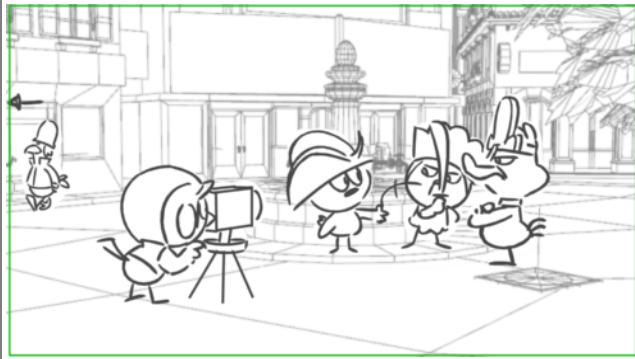

Dialogue

15. PRISCILLA (surenchérit en ôtant sa couronne)
Moi aussi, je veux jouer avec un sabre !

| Scene | Duration | Panel | Duration |
|-------|----------|-------|----------|
| 24 | 07:24 | 5 | 01:13 |

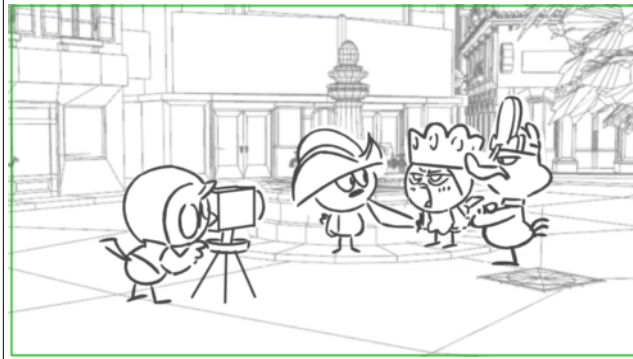

Dialogue

15. PRISCILLA (surenchérit en ôtant sa couronne)
Moi aussi, je veux jouer avec un sabre !

| Scene | Duration | Panel | Duration |
|-------|----------|-------|----------|
| 25 | 02:18 | 1 | 00:11 |

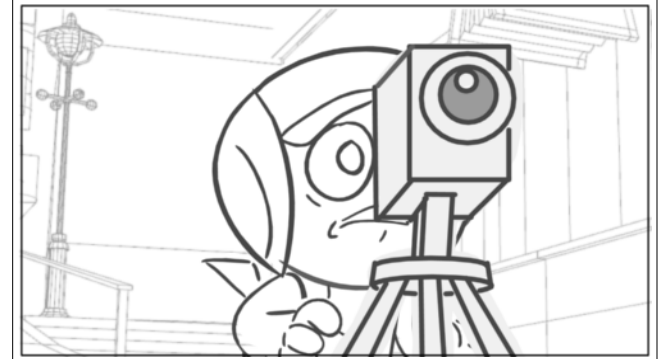

| Scene | Duration | Panel | Duration |
|-------|----------|-------|----------|
| 25 | 02:18 | 2 | 02:07 |

| Scene | Duration | Panel | Duration |
|-------|----------|-------|----------|
| 26 | 01:07 | 1 | 01:07 |

| Duration |
|----------|
| 00:16 |



Dialogue
 VALERIANO PICK UP
 Ohhhh!

| Scene | Duration | Panel | Duration |
|-------|----------|-------|----------|
| 27 | 03:19 | 1 | 03:19 |

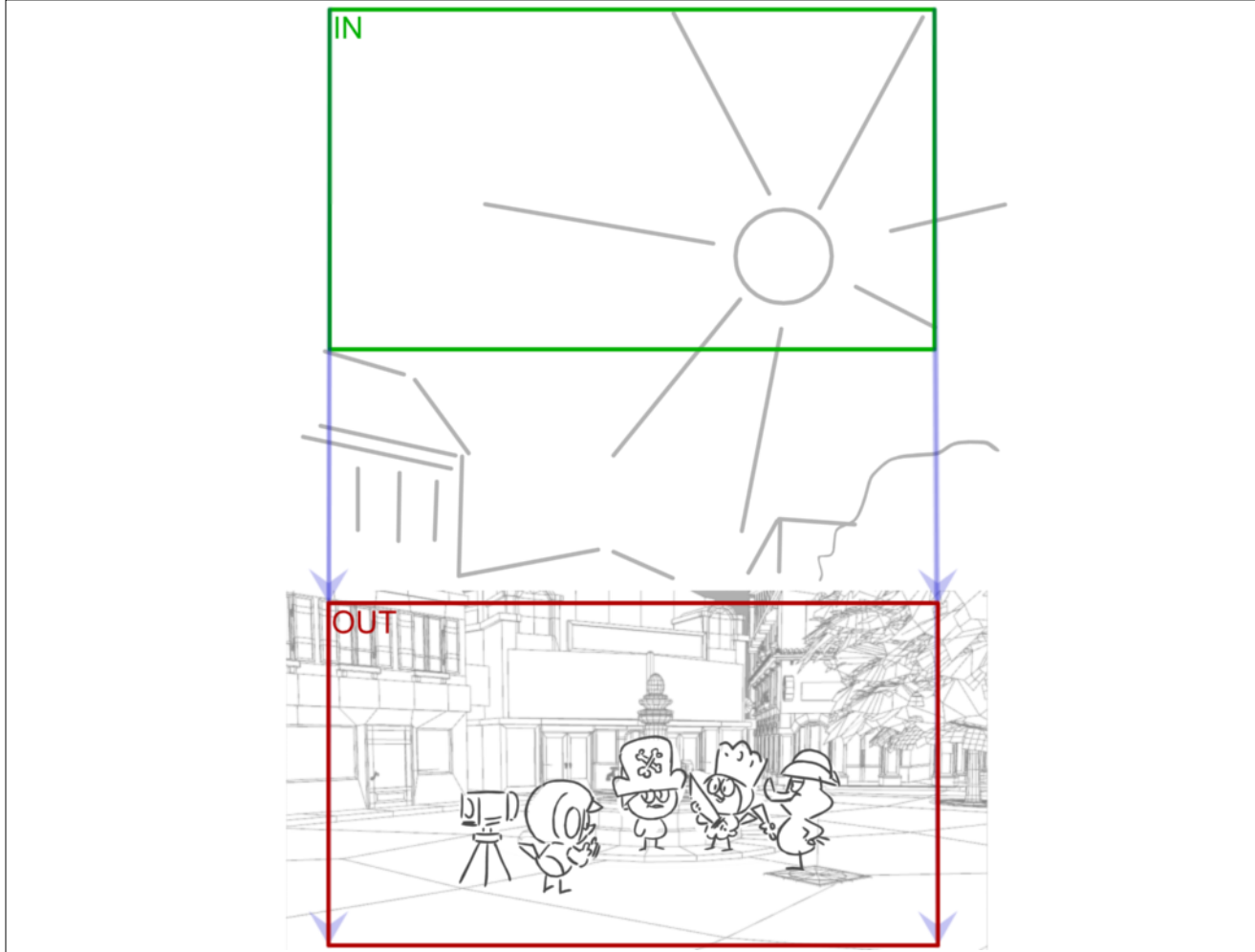

| Scene | Duration | Panel | Duration |
|-------|----------|-------|----------|
| 28 | 03:08 | 1 | 00:11 |



Dialogue

20. VALERIANO
 Bon, j'ai fait quelques changements dans l'histoire !

| Scene | Duration | Panel | Duration |
|-------|----------|-------|----------|
| 28 | 03:08 | 2 | 00:16 |



Dialogue
 20. VALERIANO
 Bon, j'ai fait quelques changements dans l'histoire !

| Scene | Duration | Panel | Duration |
|-------|----------|-------|----------|
| 28 | 03:08 | 3 | 02:06 |



| Scene | Duration | Panel | Duration |
|-------|----------|-------|----------|
| 29 | 11:08 | 1 | 01:10 |



Dialogue
 20. VALERIANO
 Alors ça raconte les aventures d'un Capitaine corsaire

| Scene | Duration | Panel | Duration |
|-------|----------|-------|----------|
| 29 | 11:08 | 2 | 01:18 |



Dialogue

20. VALERIANO
Alors ça raconte les aventures d'un
Capitaine corsaire

| Scene | Duration | Panel | Duration |
|-------|----------|-------|----------|
| 29 | 11:08 | 3 | 00:10 |

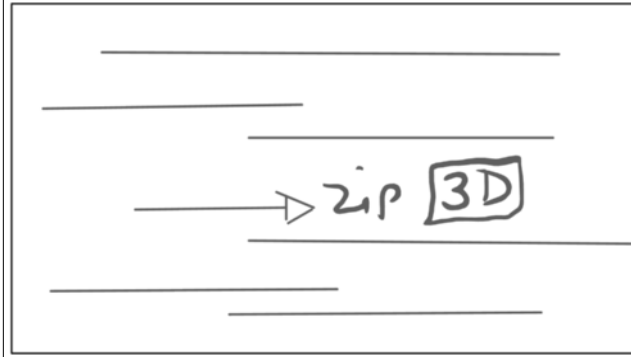

| Scene | Duration | Panel | Duration |
|-------|----------|-------|----------|
| 29 | 11:08 | 4 | 00:23 |

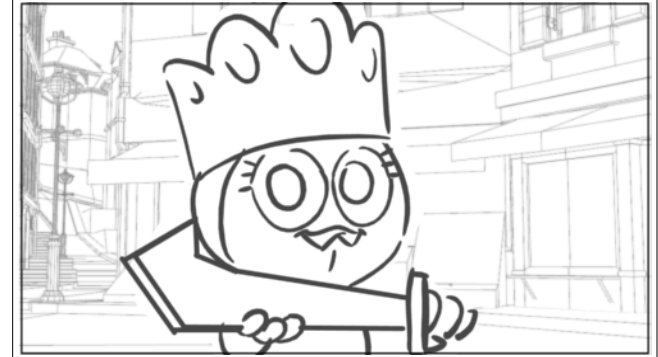

Dialogue

20. VALERIANO
et de son équipière flibustière
aventurière « Poulpita »

| Scene | Duration | Panel | Duration |
|-------|----------|-------|----------|
| 29 | 11:08 | 5 | 00:14 |



Dialogue
 20. VALERIANO
 et de son équipière flibustière
 aventurière « Poulpita »

| Scene | Duration | Panel | Duration |
|-------|----------|-------|----------|
| 29 | 11:08 | 6 | 00:17 |

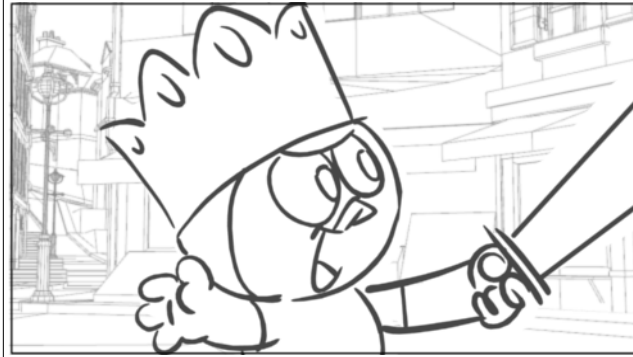

Dialogue
 20. VALERIANO
 et de son équipière flibustière
 aventurière « Poulpita »

| Scene | Duration | Panel | Duration |
|-------|----------|-------|----------|
| 29 | 11:08 | 7 | 01:06 |



Dialogue
 20. VALERIANO
 et de son équipière flibustière
 aventurière « Poulpita »

| Scene | Duration | Panel | Duration |
|-------|----------|-------|----------|
| 29 | 11:08 | 8 | 00:24 |

| Scene | Duration | Panel | Duration |
|-------|----------|-------|----------|
| 29 | 11:08 | 9 | 00:10 |

| Scene | Duration | Panel | Duration |
|-------|----------|-------|----------|
| 29 | 11:08 | 10 | 00:16 |

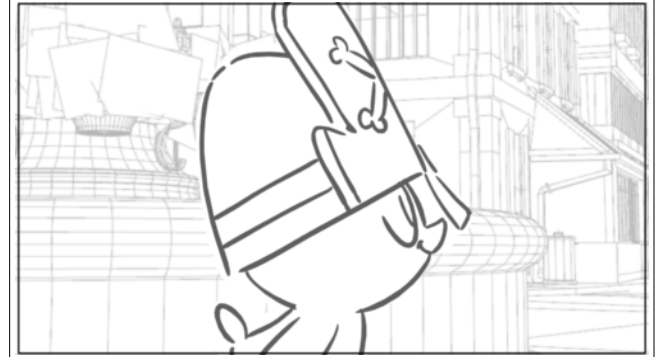
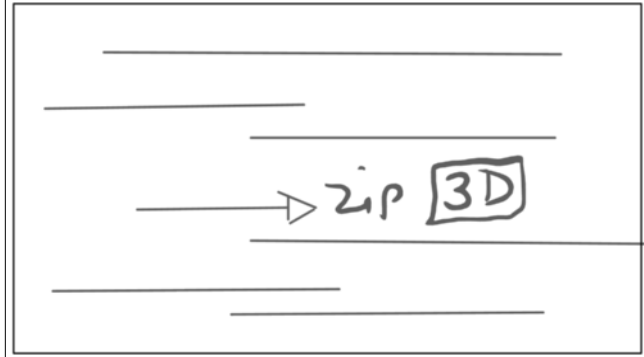

Dialogue
 20. VALERIANO
 et de son équipière flibustière
 aventurière « Poulpita »

Dialogue
 20. VALERIANO
 Et ils doivent capturer « Blanc-bec »

| Scene | Duration | Panel | Duration |
|-------|----------|-------|----------|
| 29 | 11:08 | 11 | 00:15 |

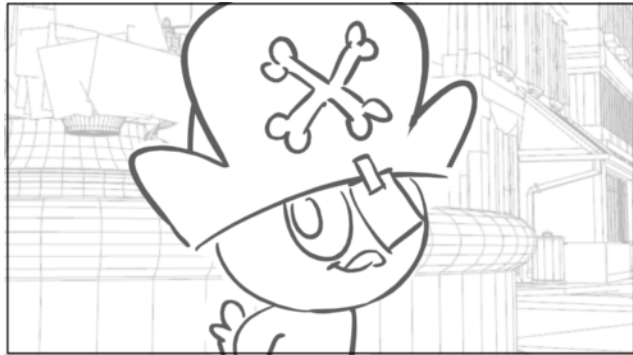

Dialogue

20. VALERIANO

Et ils doivent capturer « Blanc-bec »

| Scene | Duration | Panel | Duration |
|-------|----------|-------|----------|
| 29 | 11:08 | 12 | 01:20 |



Dialogue

20. VALERIANO

Et ils doivent capturer « Blanc-bec »

| Scene | Duration | Panel | Duration |
|-------|----------|-------|----------|
| 30 | 02:15 | 1 | 00:09 |

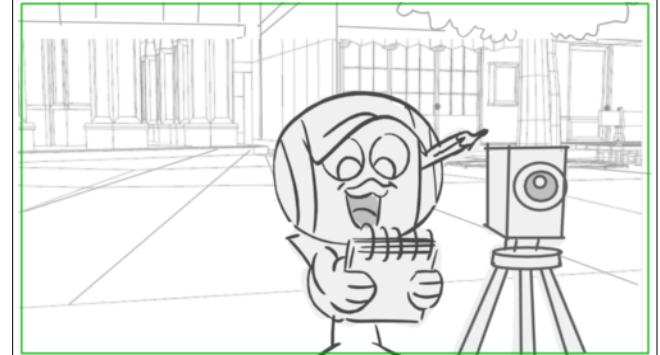

Dialogue

20. VALERIANO

le terrible pirate à coquille

| Scene | Duration | Panel | Duration |
|-------|----------|-------|----------|
| 30 | 02:15 | 2 | 00:07 |

| Scene | Duration | Panel | Duration |
|-------|----------|-------|----------|
| 30 | 02:15 | 3 | 00:08 |

| Scene | Duration | Panel | Duration |
|-------|----------|-------|----------|
| 30 | 02:15 | 4 | 00:21 |

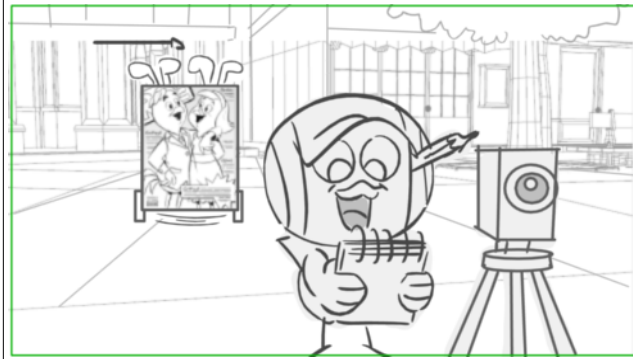
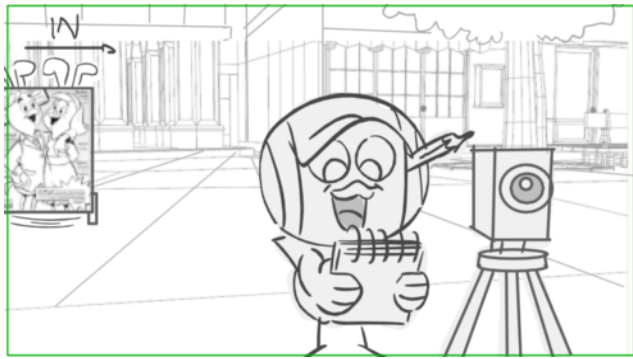

Dialogue

20. VALERIANO
le terrible pirate à coquille

Action Notes

Plus loin, derrière un tréteau publicitaire du kiosque à journaux on remarque deux paires d'oreilles de lapin (on dirait que le couple de stars en couverture du magazine people représenté sur le tréteau « a des oreilles de lapins »).

| Scene | Duration | Panel | Duration |
|-------|----------|-------|----------|
| 30 | 02:15 | 5 | 00:20 |



| Scene | Duration | Panel | Duration |
|-------|----------|-------|----------|
| 31 | 02:22 | 1 | 01:17 |

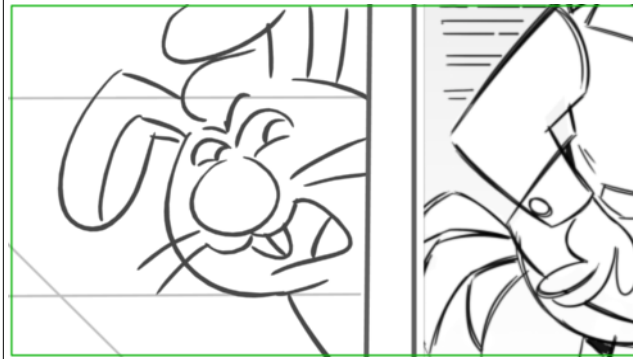

Dialogue
 17. POT (complotant)
 Avec sa caméra, Valériano est trop fort !

| Scene | Duration | Panel | Duration |
|-------|----------|-------|----------|
| 31 | 02:22 | 2 | 01:05 |



| Scene | Duration | Panel | Duration |
|-------|----------|-------|----------|
| 32 | 06:09 | 1 | 01:19 |

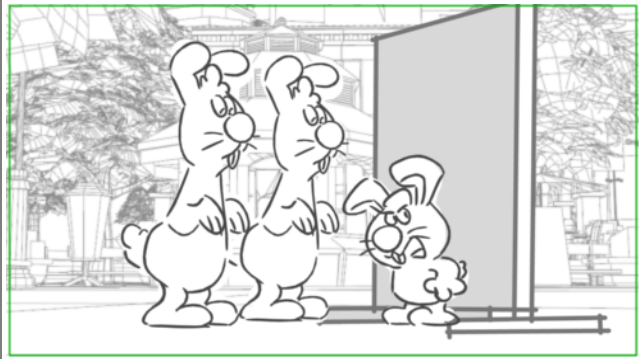

Dialogue

17. POT (complotant)
Il pourrait gagner le concours!

| Scene | Duration | Panel | Duration |
|-------|----------|-------|----------|
| 32 | 06:09 | 2 | 02:12 |

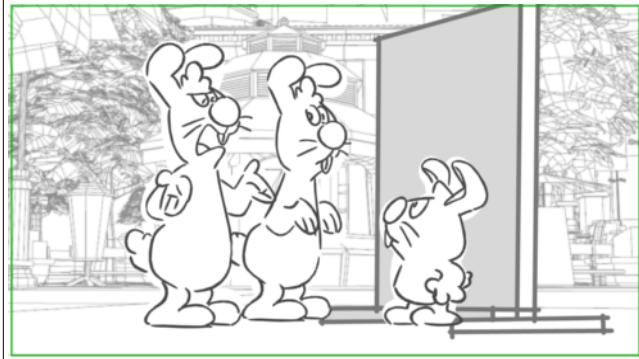

Dialogue

18. MOT (benêt, en croquant une carotte)
Baah, t'avais dit qu'il arriverait pas à faire de film?

| Scene | Duration | Panel | Duration |
|-------|----------|-------|----------|
| 32 | 06:09 | 3 | 02:03 |

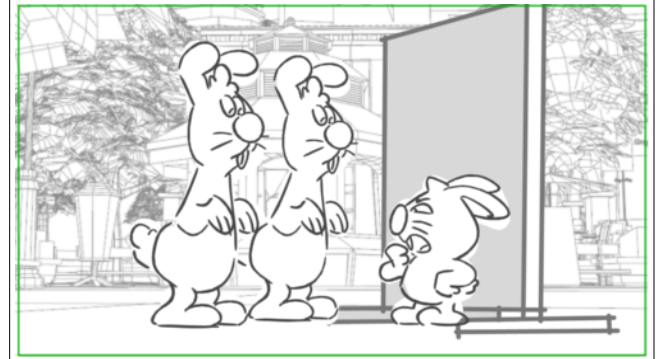

Dialogue

19. POT (sourire machiavélique)
On doit en être sûr.

| Scene | Duration | Panel | Duration |
|-------|----------|-------|----------|
| 33 | 04:13 | 1 | 01:19 |

| Scene | Duration | Panel | Duration |
|-------|----------|-------|----------|
| 33 | 04:13 | 2 | 02:19 |

| Scene | Duration | Panel | Duration |
|-------|----------|-------|----------|
| 34 | 00:14 | 1 | 00:04 |

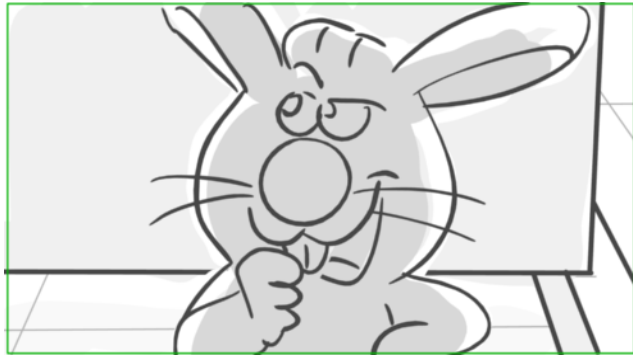

Dialogue
 19. POT (sourire machiavélique)
 Alors son film de pirates?

Dialogue
 19. POT (sourire machiavélique)
 on va le saborder !

| Scene | Duration | Panel | Duration |
|-------|----------|-------|----------|
| 34 | 00:14 | 2 | 00:10 |



| Scene | Duration | Panel | Duration |
|-------|----------|-------|----------|
| 35 | 32:06 | 1 | 02:19 |

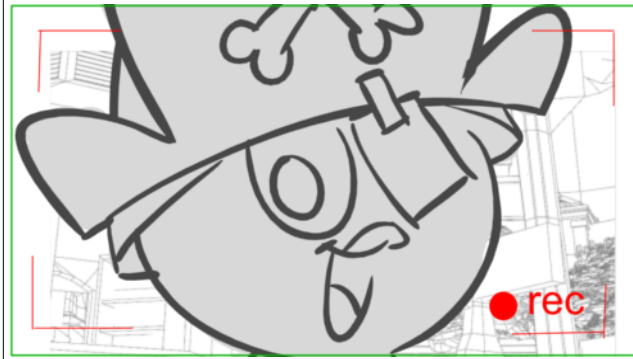

Dialogue
 21. CALIMERO
 « Les aventures du Corsaire palmé »

Action Notes
 4. PLACE BASSE ? PRES D'UN BANC / EXT.
 JOUR / SCENE 1 DU FILM DE VALERIANO

| Scene | Duration | Panel | Duration |
|-------|----------|-------|----------|
| 35 | 32:06 | 2 | 01:13 |

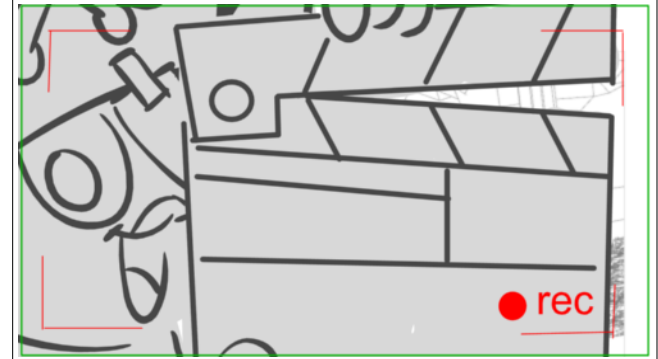

Dialogue
 21. CALIMERO
 scenel

Action Notes
 4. PLACE BASSE ? PRES D'UN BANC / EXT.
 JOUR / SCENE 1 DU FILM DE VALERIANO

| Scene | Duration | Panel | Duration |
|-------|----------|-------|----------|
| 35 | 32:06 | 3 | 00:13 |

| Scene | Duration | Panel | Duration |
|-------|----------|-------|----------|
| 35 | 32:06 | 4 | 00:09 |

| Scene | Duration | Panel | Duration |
|-------|----------|-------|----------|
| 35 | 32:06 | 5 | 02:00 |

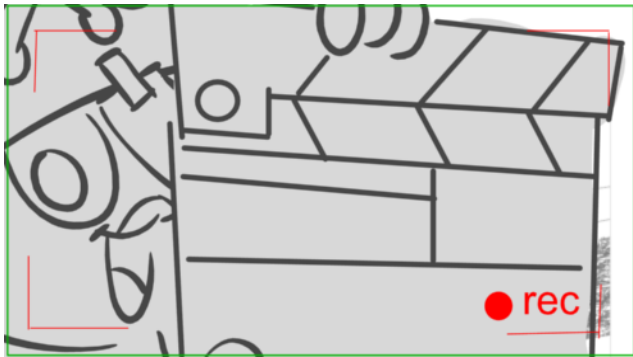

Dialogue
 21. CALIMERO
 première!

 SFX CLAP

Dialogue
 22. VALERIANO (l'œil rivé à la caméra)
 Et? Action !

Dialogue
 22. VALERIANO (l'œil rivé à la caméra)
 Et? Action !

| Scene | Duration | Panel | Duration |
|-------|----------|-------|----------|
| 35 | 32:06 | 6 | 01:21 |



Dialogue

23. PRISCILLA (surjoué)
Capitaine Pierrot

| Scene | Duration | Panel | Duration |
|-------|----------|-------|----------|
| 35 | 32:06 | 7 | 01:21 |



Dialogue

23. PRISCILLA (surjoué)
l'heure est grave !

| Scene | Duration | Panel | Duration |
|-------|----------|-------|----------|
| 35 | 32:06 | 8 | 01:16 |



Dialogue

23. PRISCILLA (surjoué)
« Blanc-bec » le pirate répand la
terreur dans nos mers !

| Scene | Duration | Panel | Duration |
|-------|----------|-------|----------|
| 35 | 32:06 | 9 | 01:22 |

**Dialogue**

23. PRISCILLA (surjoué)
« Blanc-bec » le pirate répand la terreur dans nos mers !

| Scene | Duration | Panel | Duration |
|-------|----------|-------|----------|
| 35 | 32:06 | 10 | 01:10 |

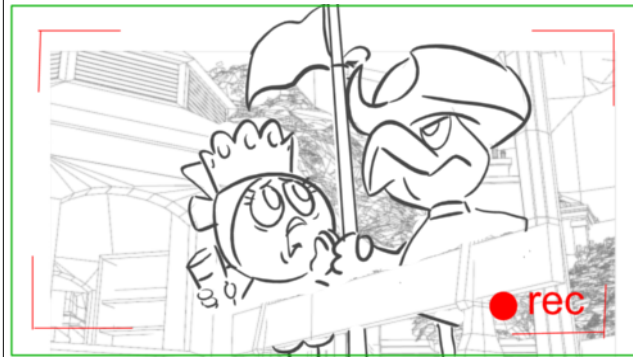
**Dialogue**

23. PRISCILLA (surjoué)
Il a déjà pillé tous les trésors du royaume?

| Scene | Duration | Panel | Duration |
|-------|----------|-------|----------|
| 35 | 32:06 | 11 | 01:17 |

**Dialogue**

23. PRISCILLA (surjoué)
Il a déjà pillé tous les trésors du royaume?

| Scene | Duration | Panel | Duration |
|-------|----------|-------|----------|
| 35 | 32:06 | 12 | 02:00 |

| Scene | Duration | Panel | Duration |
|-------|----------|-------|----------|
| 35 | 32:06 | 13 | 02:10 |

| Scene | Duration | Panel | Duration |
|-------|----------|-------|----------|
| 35 | 32:06 | 14 | 01:09 |



Dialogue

23. PRISCILLA (surjoué)
et même les bonbons !



Dialogue

24. PIERROT (sentencieux)
Vous z?inquiétez pas, Poulpita !.



Dialogue

24. PIERROT (sentencieux)
Je le rattraperai,

| Scene | Duration | Panel | Duration |
|-------|----------|-------|----------|
| 35 | 32:06 | 15 | 02:00 |

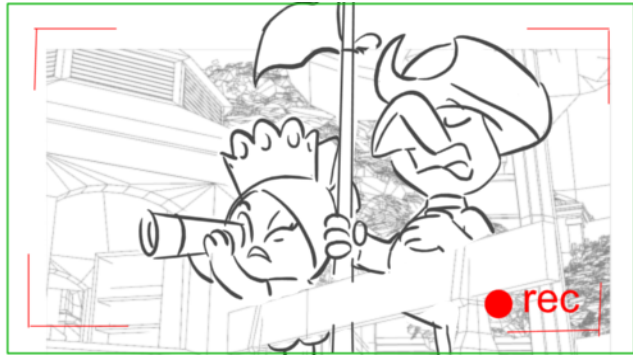
**Dialogue**

24. PIERROT (sentencieux)
Je le rattraperai, foi de corsaire
canard !

| Scene | Duration | Panel | Duration |
|-------|----------|-------|----------|
| 35 | 32:06 | 16 | 02:10 |

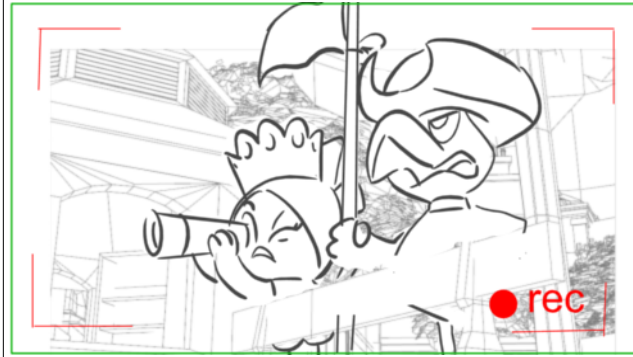
**Dialogue**

24. PIERROT (sentencieux)
J'suis pas un mou de la voile, moi !

| Scene | Duration | Panel | Duration |
|-------|----------|-------|----------|
| 35 | 32:06 | 17 | 00:16 |

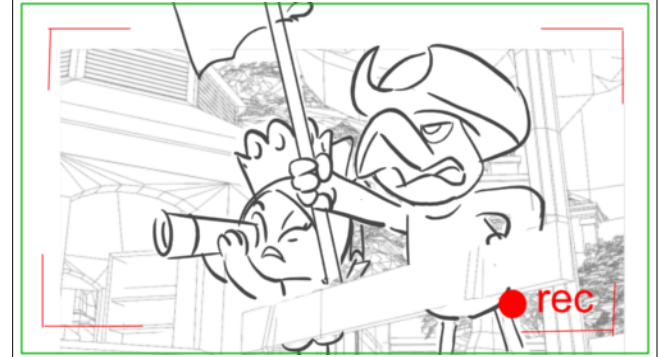
**Dialogue**

24. PIERROT (sentencieux)
J?vais?

| Scene | Duration | Panel | Duration |
|-------|----------|-------|----------|
| 35 | 32:06 | 18 | 01:00 |

| Scene | Duration | Panel | Duration |
|-------|----------|-------|----------|
| 35 | 32:06 | 19 | 00:21 |

| Scene | Duration | Panel | Duration |
|-------|----------|-------|----------|
| 35 | 32:06 | 20 | 01:02 |

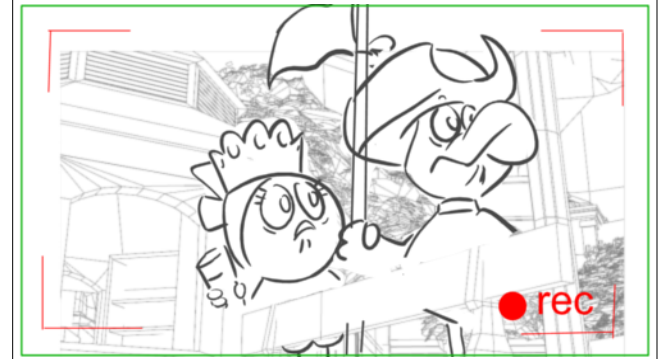

Dialogue
 25. POT (tirant la langue et feignant la peur)
 Bleuaaarrrrr !

Dialogue
 25. POT (tirant la langue et feignant la peur)
 J'ai trop peurrrrrrrr !

| Scene | Duration | Panel | Duration |
|-------|----------|-------|----------|
| 35 | 32:06 | 21 | 00:12 |

| Scene | Duration | Panel | Duration |
|-------|----------|-------|----------|
| 35 | 32:06 | 22 | 00:15 |

| Scene | Duration | Panel | Duration |
|-------|----------|-------|----------|
| 36 | 02:23 | 1 | 00:13 |

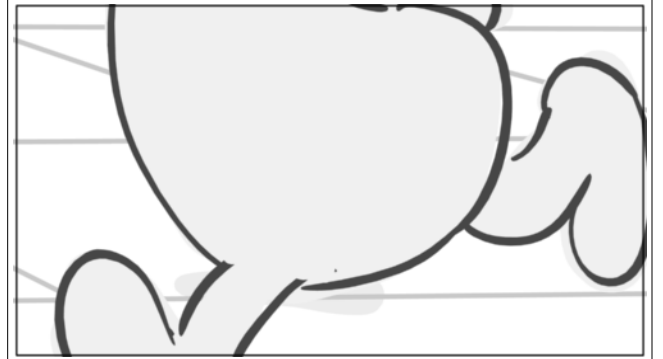

Dialogue
 26. VALERIANO (criant)
 Coupez !

Action Notes
 START POSE NO HOLD

| Scene | Duration | Panel | Duration |
|-------|----------|-------|----------|
| 36 | 02:23 | 2 | 00:18 |



| Scene | Duration | Panel | Duration |
|-------|----------|-------|----------|
| 36 | 02:23 | 3 | 01:17 |

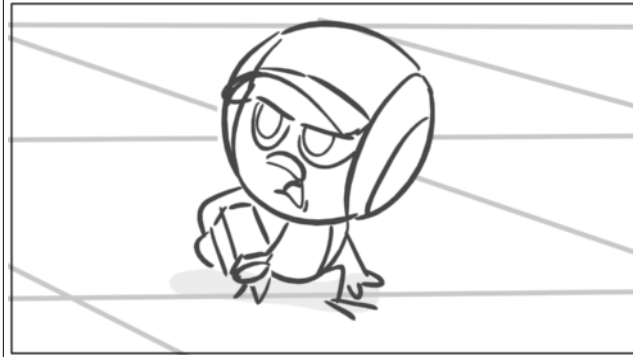

Dialogue

32. VALERIANO (furieux)
Ils ont tout gâché mon plan !

| Scene | Duration | Panel | Duration |
|-------|----------|-------|----------|
| 37 | 10:19 | 1 | 00:11 |

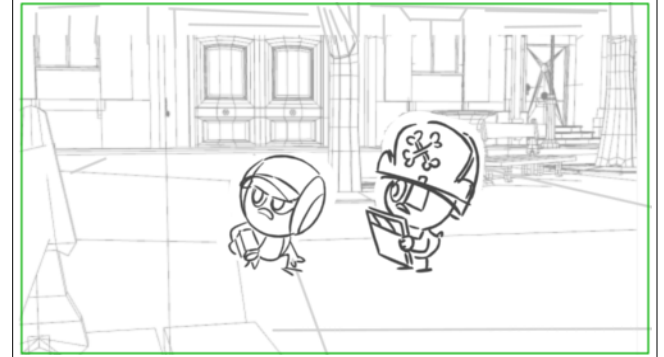

Dialogue

27. POT/COT/MOT (ricanant)
Arf ! Arf ! Arf !

Action Notes

CALIMERO porte le clap.

| Scene | Duration | Panel | Duration |
|-------|----------|-------|----------|
| 37 | 10:19 | 2 | 01:00 |

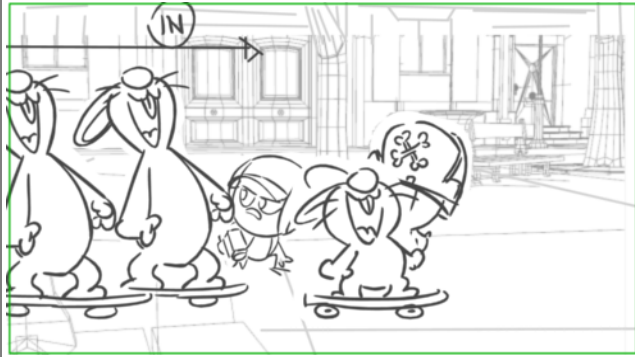

Dialogue
 27. POT/COT/MOT (ricanant)
 Arf ! Arf ! Arf !

Action Notes
 Les Lapinets leur passent devant en skate

| Scene | Duration | Panel | Duration |
|-------|----------|-------|----------|
| 37 | 10:19 | 3 | 01:00 |

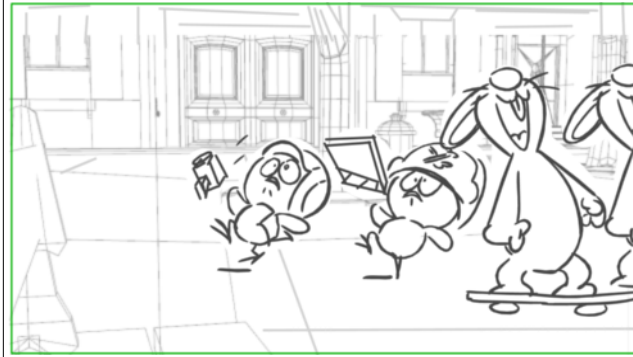

Dialogue
 27. POT/COT/MOT (ricanant)
 Arf ! Arf ! Arf !

Action Notes
 Valeriano et CALIMERO déséquilibrés.

| Scene | Duration | Panel | Duration |
|-------|----------|-------|----------|
| 37 | 10:19 | 4 | 01:00 |



Dialogue
 27. POT/COT/MOT (ricanant)
 T?y arriveras jamais à faire ton film !

| Scene | Duration | Panel | Duration |
|-------|----------|-------|----------|
| 37 | 10:19 | 5 | 01:00 |

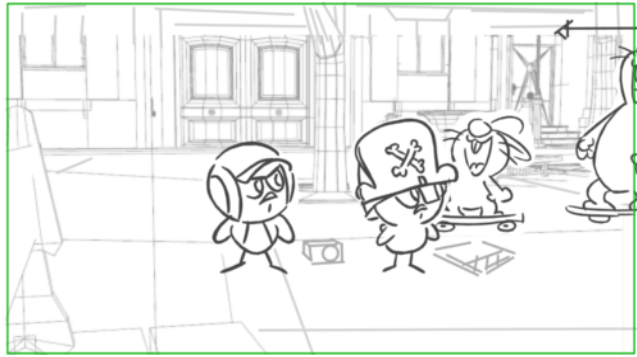

Dialogue
 27. POT/COT/MOT (ricanant)
 T?y arriveras jamais à faire ton film !

| Scene | Duration | Panel | Duration |
|-------|----------|-------|----------|
| 37 | 10:19 | 6 | 00:13 |

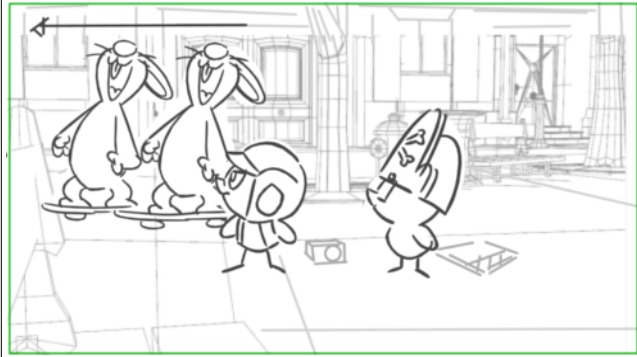

Dialogue
 27. POT/COT/MOT (ricanant)
 T?y arriveras jamais à faire ton film !

| Scene | Duration | Panel | Duration |
|-------|----------|-------|----------|
| 37 | 10:19 | 7 | 00:23 |

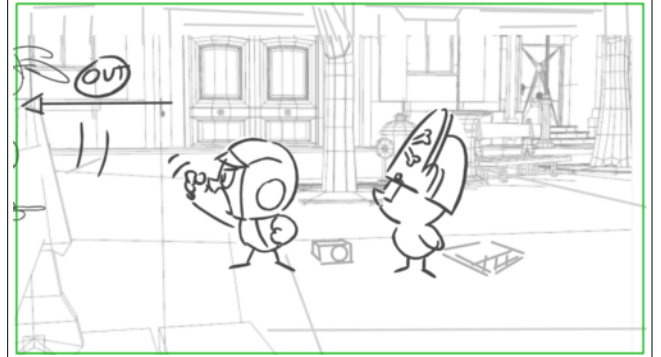

Dialogue
 28. VALERIANO (criant)
 Héé ! Ce sera toujours mieux que le votre,

| Scene | Duration | Panel | Duration |
|-------|----------|-------|----------|
| 37 | 10:19 | 8 | 02:04 |

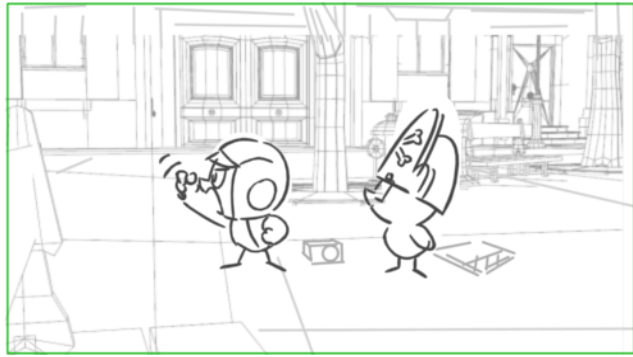

Dialogue

28. VALERIANO (criant)
Héé ! Ce sera toujours mieux que le
votre,

| Scene | Duration | Panel | Duration |
|-------|----------|-------|----------|
| 37 | 10:19 | 9 | 01:14 |

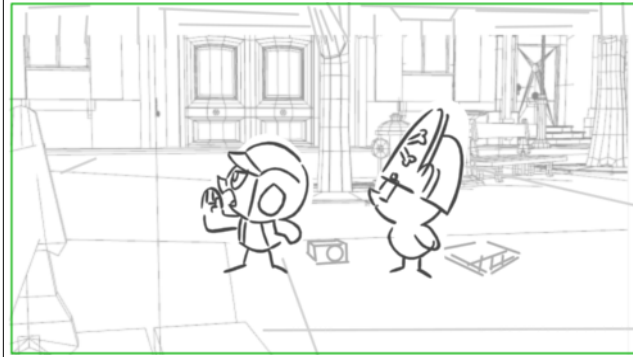

Dialogue

28. VALERIANO (criant)
bande de carottes râpées !

| Scene | Duration | Panel | Duration |
|-------|----------|-------|----------|
| 37 | 10:19 | 10 | 01:04 |

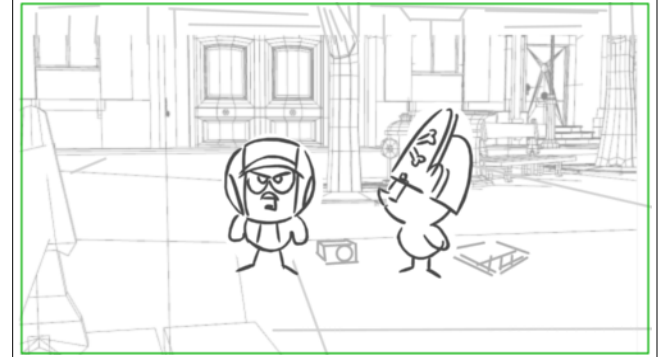

Dialogue

28. VALERIANO
Bon,

| Scene | Duration | Panel | Duration |
|-------|----------|-------|----------|
| 38 | 10:18 | 1 | 01:08 |

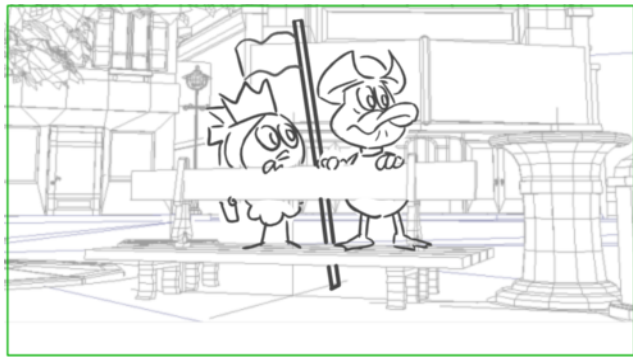

Dialogue

35. VALERIANO
On va tourner la scène suivante,

| Scene | Duration | Panel | Duration |
|-------|----------|-------|----------|
| 38 | 10:18 | 2 | 01:05 |



Dialogue

35. VALERIANO
On va tourner la scène suivante,

| Scene | Duration | Panel | Duration |
|-------|----------|-------|----------|
| 38 | 10:18 | 3 | 01:06 |



Dialogue

35. VALERIANO
On va tourner la scène suivante,

| Scene | Duration | Panel | Duration |
|-------|----------|-------|----------|
| 38 | 10:18 | 4 | 02:00 |

| Scene | Duration | Panel | Duration |
|-------|----------|-------|----------|
| 38 | 10:18 | 5 | 00:20 |

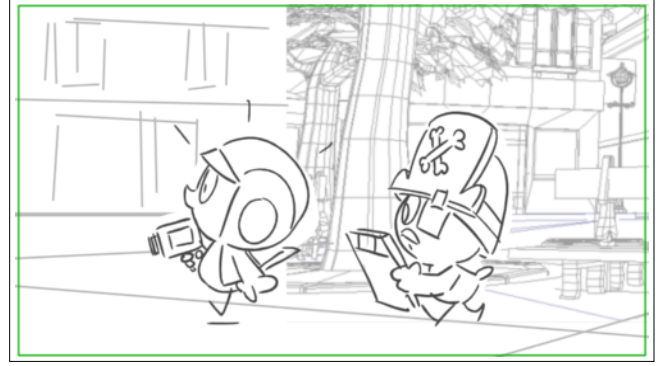
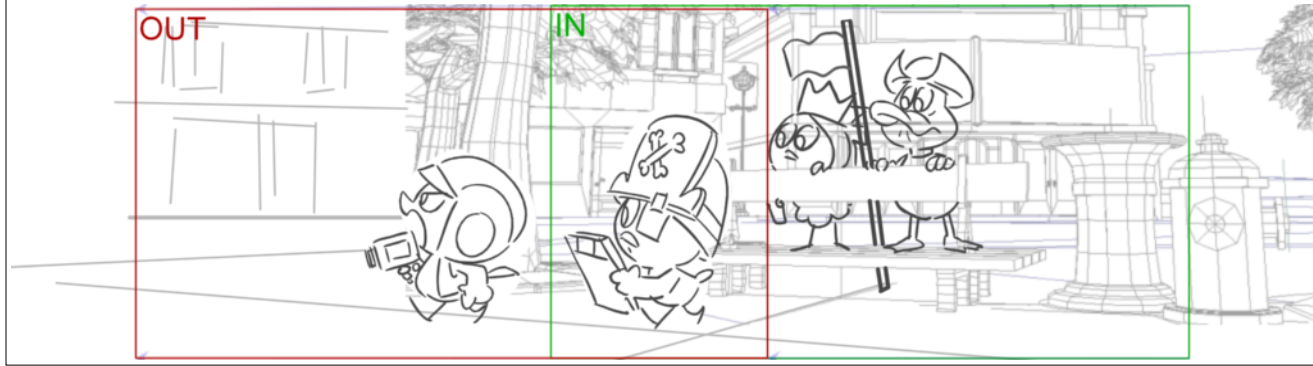

Dialogue

35. VALERIANO
sur le galion du Capitaine corsaire !

Action Notes

(un temps,

| Scene | Duration | Panel | Duration |
|-------|----------|-------|----------|
| 38 | 10:18 | 6 | 01:00 |



Dialogue

PICK UP VALERIANO
Euh!

| Scene | Duration | Panel | Duration |
|-------|----------|-------|----------|
| 38 | 10:18 | 7 | 01:22 |



Dialogue

35. VALERIANO
Manque plus qu'à trouver un endroit qui
ressemble à un galion...

| Scene | Duration | Panel | Duration |
|-------|----------|-------|----------|
| 38 | 10:18 | 8 | 01:07 |

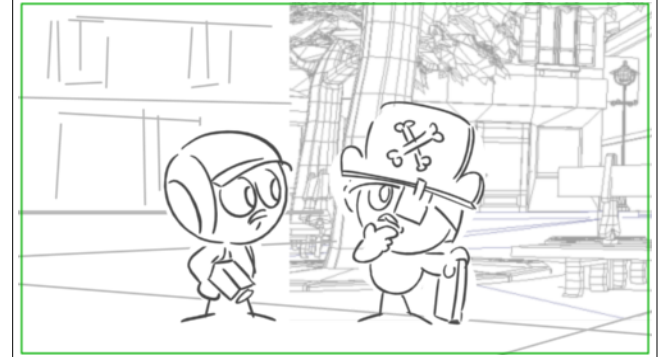

Dialogue

PICK UP CALIMERO
Hum!

| Scene | Duration | Panel | Duration |
|-------|----------|-------|----------|
| 39 | 02:00 | 1 | 02:00 |



Dialogue

36. CALIMERO
J'ai une idée Valériano !

| Scene | Duration | Panel | Duration |
|-------|----------|-------|----------|
| 40 | 09:03 | 1 | 01:00 |

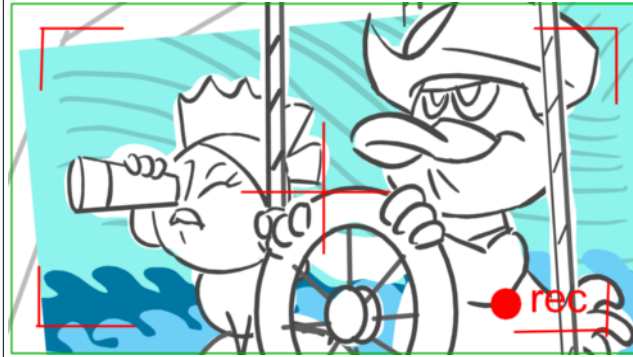

Action Notes

5. PARC ? AIRE DE JEUX / EXT. JOUR /
SCENE 2 DU FILM DE VALERIANO

| Scene | Duration | Panel | Duration |
|-------|----------|-------|----------|
| 40 | 09:03 | 2 | 01:02 |

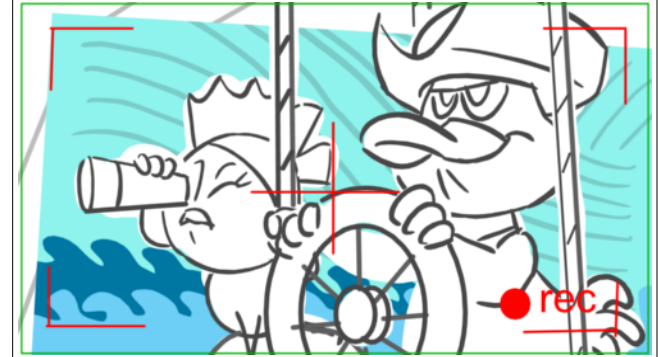

Action Notes

Le Capitaine Pierrot et son alliée Priscilla la flibustière sont assis en tenant les cordes des « haubans d'un navire » sur un « fond de mer qui bouge avec la houle » (on croit qu'ils sont sur un galion).

| Scene | Duration | Panel | Duration |
|-------|----------|-------|----------|
| 40 | 09:03 | 3 | 01:04 |

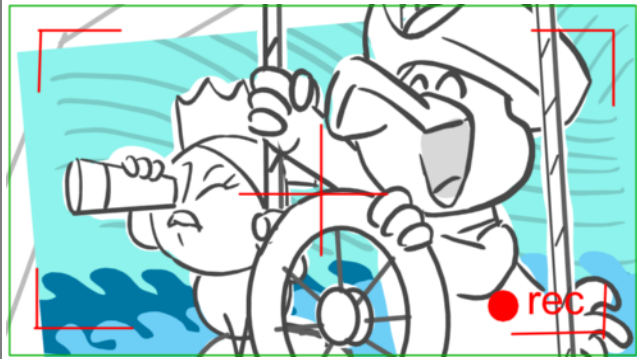

Dialogue

37. PIERROT (clamant à un équipage imaginaire)
Toutes voiles dehors !

| Scene | Duration | Panel | Duration |
|-------|----------|-------|----------|
| 40 | 09:03 | 4 | 00:09 |

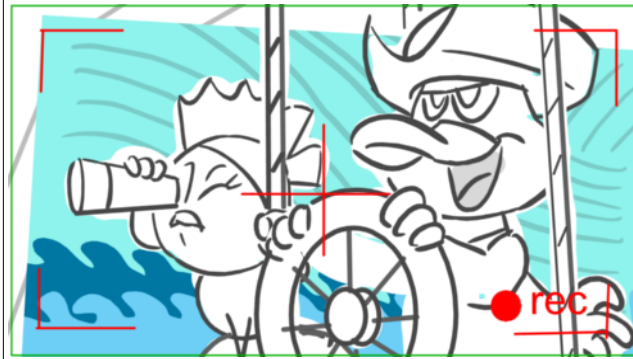

Dialogue

37. PIERROT (clamant à un équipage imaginaire)
Cap à 90°

| Scene | Duration | Panel | Duration |
|-------|----------|-------|----------|
| 40 | 09:03 | 5 | 01:07 |

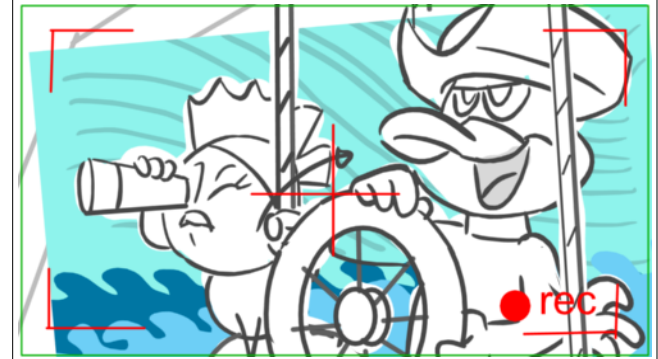

Dialogue

37. PIERROT (clamant à un équipage imaginaire)
Cap à 90°

| Scene | Duration | Panel | Duration |
|-------|----------|-------|----------|
| 40 | 09:03 | 6 | 00:19 |

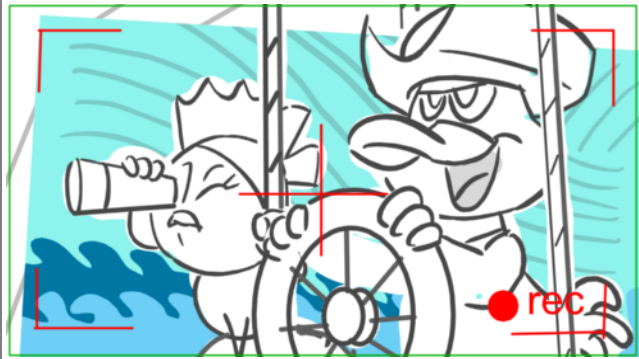

Dialogue

37. PIERROT (clamant à un équipage imaginaire)
de l'hypoténu...

| Scene | Duration | Panel | Duration |
|-------|----------|-------|----------|
| 40 | 09:03 | 7 | 01:17 |

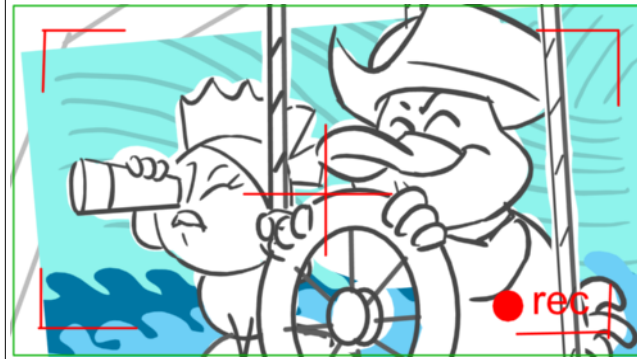

Dialogue

37. PIERROT (clamant à un équipage imaginaire)
de l'hypoténuse

| Scene | Duration | Panel | Duration |
|-------|----------|-------|----------|
| 40 | 09:03 | 8 | 00:21 |

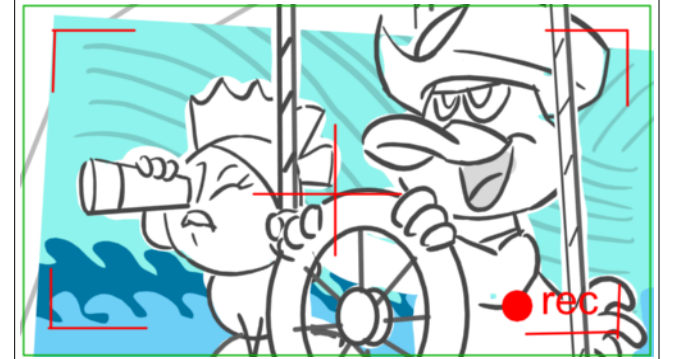

Dialogue

37. PIERROT (clamant à un équipage imaginaire)
Sud-Est !

| Scene | Duration | Panel | Duration |
|-------|----------|-------|----------|
| 40 | 09:03 | 9 | 00:24 |

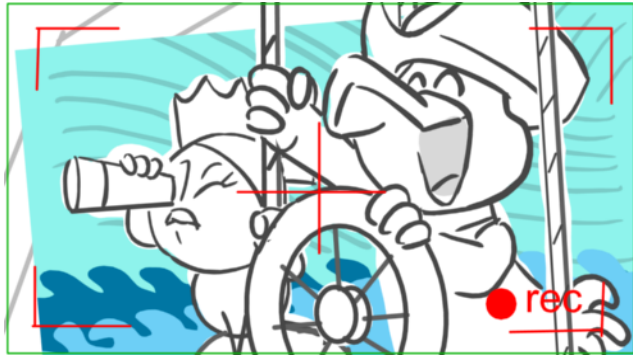

Dialogue

37. PIERROT (clamant à un équipage imaginaire)
Sud-Ouest !

| Scene | Duration | Panel | Duration |
|-------|----------|-------|----------|
| 41 | 04:13 | 1 | 01:10 |



Dialogue

38. PRISCILLA (brandissant son sabre à l'horizon)
N'ayez crainte Capitaine,

Action Notes

Caliméro, placé en-dessous fait pivoter doucement le billboard

| Scene | Duration | Panel | Duration |
|-------|----------|-------|----------|
| 41 | 04:13 | 2 | 01:02 |



| Scene | Duration | Panel | Duration |
|-------|----------|-------|----------|
| 41 | 04:13 | 3 | 00:24 |



| Scene | Duration | Panel | Duration |
|-------|----------|-------|----------|
| 41 | 04:13 | 4 | 01:02 |



| Scene | Duration | Panel | Duration |
|-------|----------|-------|----------|
| 42 | 02:16 | 1 | 01:03 |

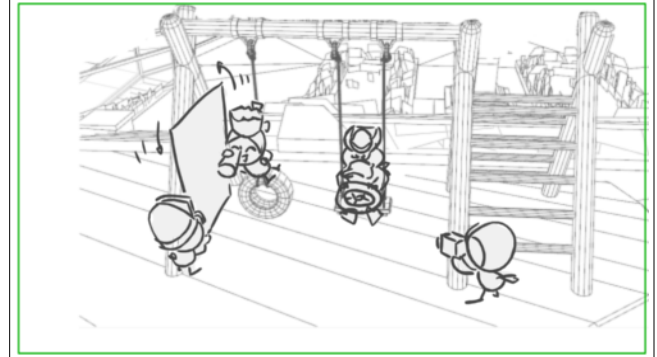

Dialogue

38. PRISCILLA (brandissant son sabre à l'horizon)
 N'ayez crainte Capitaine, le « Homard flamboyant » est le navire le plus rapide de la flotte !

| Scene | Duration | Panel | Duration |
|-------|----------|-------|----------|
| 42 | 02:16 | 2 | 01:01 |

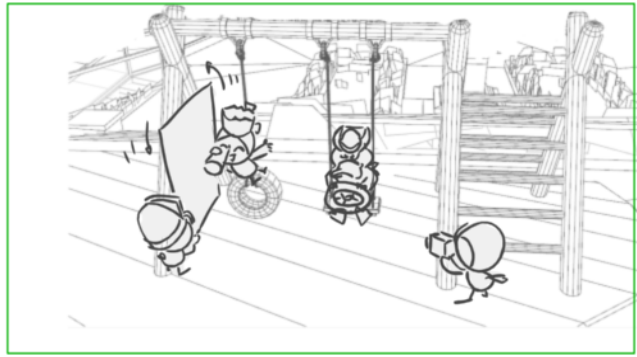

| Scene | Duration | Panel | Duration |
|-------|----------|-------|----------|
| 42 | 02:16 | 3 | 00:12 |

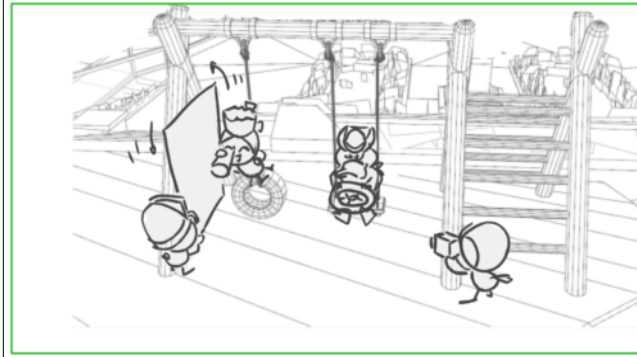

| Scene | Duration | Panel | Duration |
|-------|----------|-------|----------|
| 43 | 08:14 | 1 | 01:07 |

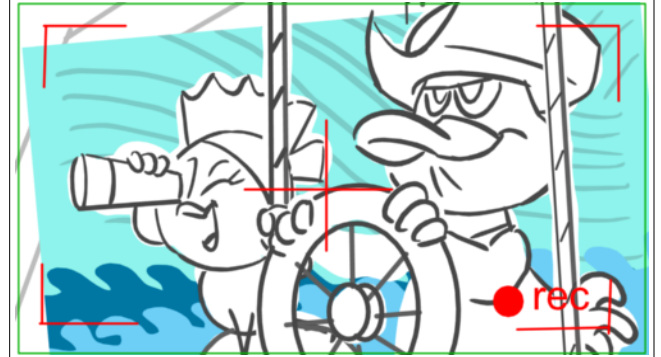

Dialogue

38. PRISCILLA (brandissant son sabre à l'horizon)

Nous rattraperons ce vilain pirate avant l'heure du goûter !

| Scene | Duration | Panel | Duration |
|-------|----------|-------|----------|
| 43 | 08:14 | 2 | 01:05 |

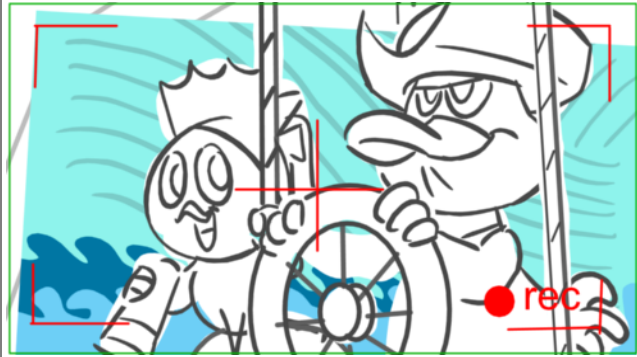

| Scene | Duration | Panel | Duration |
|-------|----------|-------|----------|
| 43 | 08:14 | 3 | 02:02 |

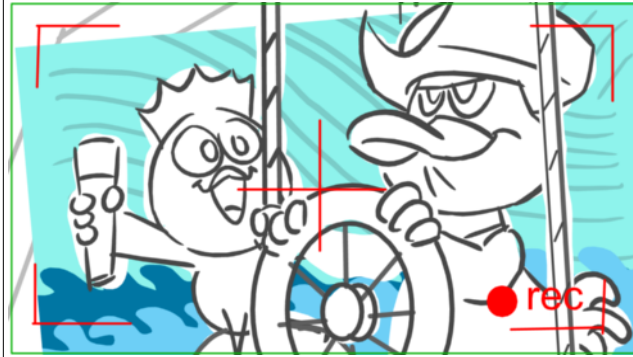

| Scene | Duration | Panel | Duration |
|-------|----------|-------|----------|
| 43 | 08:14 | 4 | 01:00 |

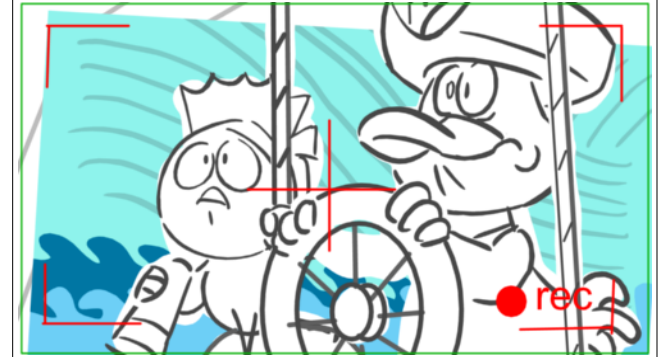

Dialogue

39. POT (OFF, criant)
A l?abordaaaage !

| Scene | Duration | Panel | Duration |
|-------|----------|-------|----------|
| 43 | 08:14 | 5 | 01:00 |

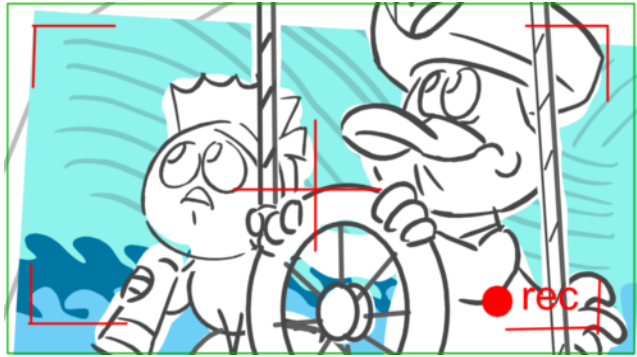

Dialogue

39. POT (OFF, criant)
A l?abordaaaaage !

| Scene | Duration | Panel | Duration |
|-------|----------|-------|----------|
| 43 | 08:14 | 6 | 01:00 |

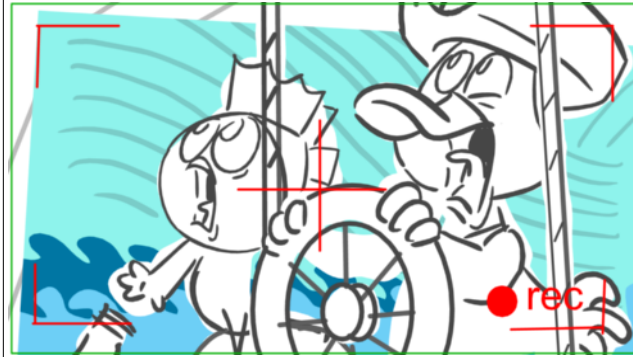

Dialogue

40. PIERROT/PRISCILLA (esquivant les carottes)
Héééé !

| Scene | Duration | Panel | Duration |
|-------|----------|-------|----------|
| 43 | 08:14 | 7 | 01:00 |

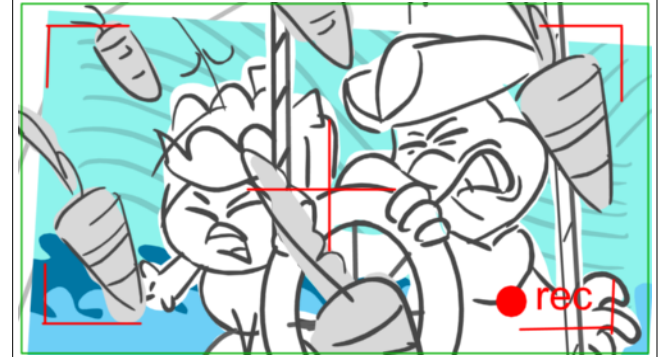

Dialogue

40. PIERROT/PRISCILLA (esquivant les carottes)
Héééé !

Action Notes

Pierrot et Priscilla sont assaillis par des projections de carottes

| Scene | Duration | Panel | Duration |
|-------|----------|-------|----------|
| 44 | 03:00 | 1 | 01:00 |

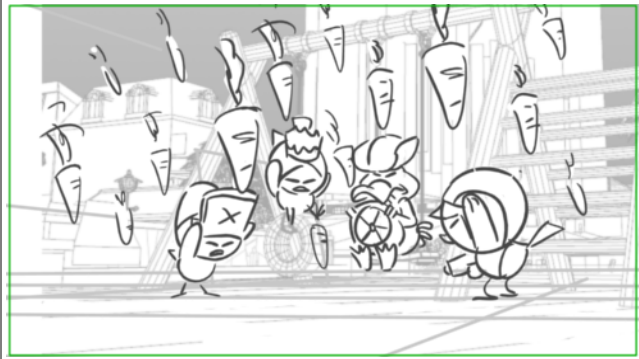

| Scene | Duration | Panel | Duration |
|-------|----------|-------|----------|
| 44 | 03:00 | 2 | 01:00 |

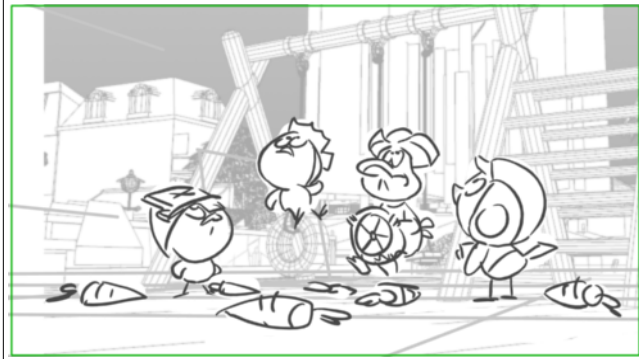

| Scene | Duration | Panel | Duration |
|-------|----------|-------|----------|
| 44 | 03:00 | 3 | 01:00 |

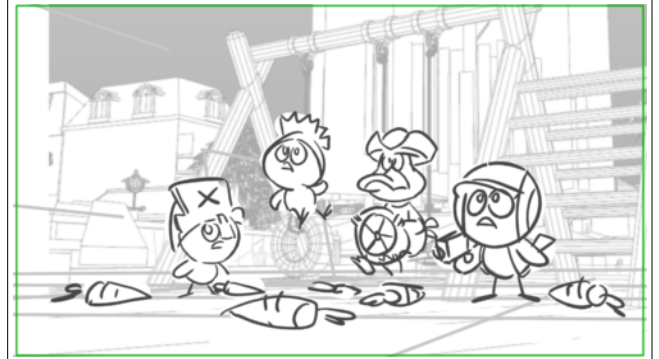

Dialogue

27. POT/COT/MOT (ricanant)
 Arf ! Arf ! Arf !

| Scene | Duration | Panel | Duration |
|-------|----------|-------|----------|
| 45 | 03:24 | 1 | 01:00 |

| Scene | Duration | Panel | Duration |
|-------|----------|-------|----------|
| 45 | 03:24 | 2 | 01:00 |

| Scene | Duration | Panel | Duration |
|-------|----------|-------|----------|
| 45 | 03:24 | 3 | 00:12 |

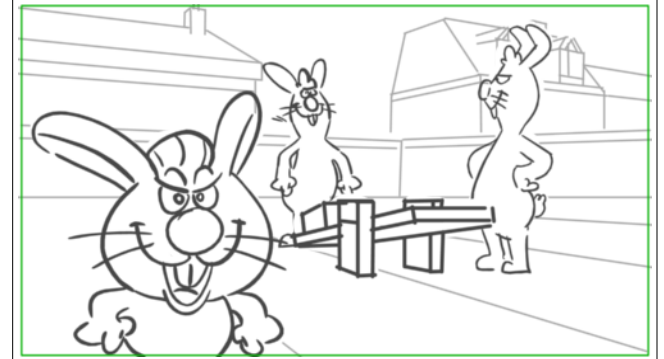
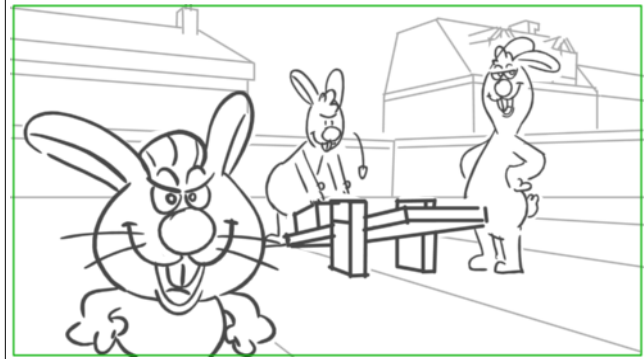

Dialogue
 27. POT/COT/MOT (ricanant)
 Arf ! Arf ! Arf !

Dialogue
 27. POT/COT/MOT (ricanant)
 Arf ! Arf ! Arf !

Dialogue
 27. POT/COT/MOT (ricanant)
 Arf ! Arf ! Arf !

Action Notes
 Cot place des carottes sur l'assise
 d'un tape-cul et Mot appuie d'un coup
 sec avec son pied sur l'assise opposée
 afin de « catapulter » les carottes sur
 nos petits acteurs. DZOING !



| Scene | Duration | Panel | Duration |
|-------|----------|-------|----------|
| 45 | 03:24 | 4 | 00:12 |

| Scene | Duration | Panel | Duration |
|-------|----------|-------|----------|
| 45 | 03:24 | 5 | 01:00 |

| Scene | Duration | Panel | Duration |
|-------|----------|-------|----------|
| 46 | 00:19 | 1 | 00:09 |

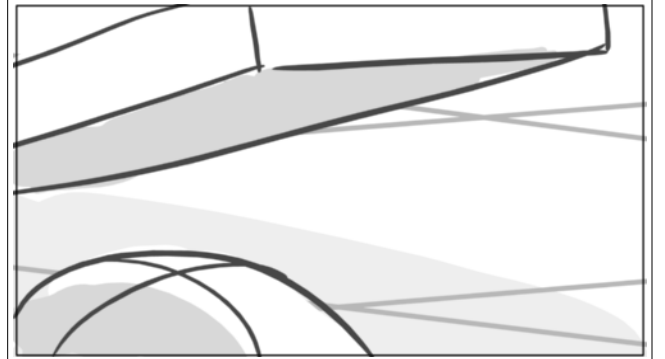
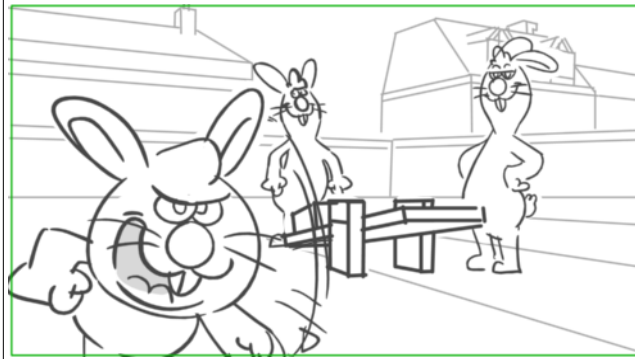
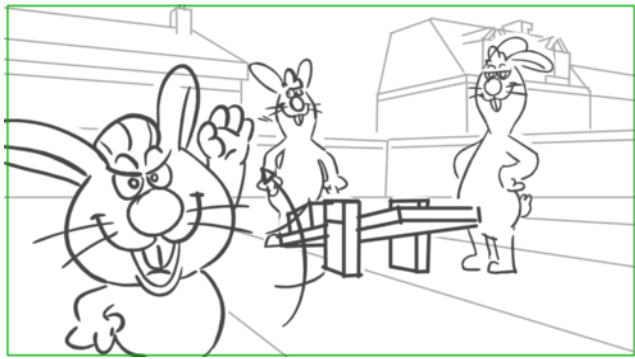

Dialogue
PICK UP POT
Attention!

Dialogue
PICK UP POT
Feu!



| Scene | Duration | Panel | Duration |
|-------|----------|-------|----------|
| 46 | 00:19 | 2 | 00:10 |

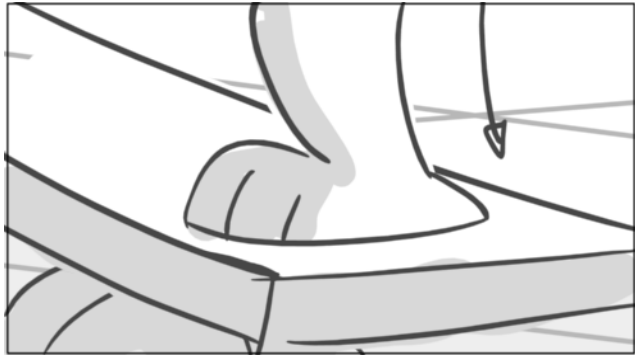

| Scene | Duration | Panel | Duration |
|-------|----------|-------|----------|
| 47 | 01:02 | 1 | 00:05 |

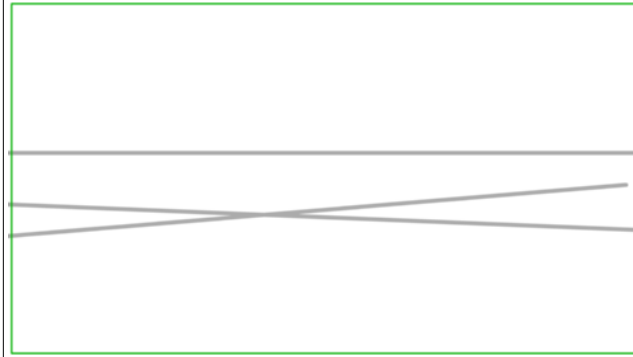

| Scene | Duration | Panel | Duration |
|-------|----------|-------|----------|
| 47 | 01:02 | 2 | 00:05 |

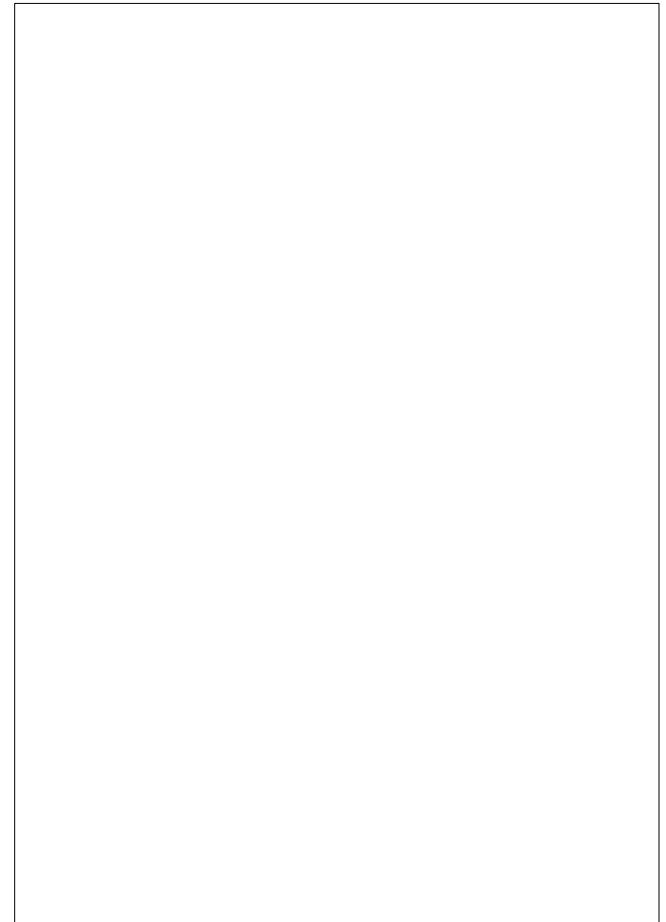
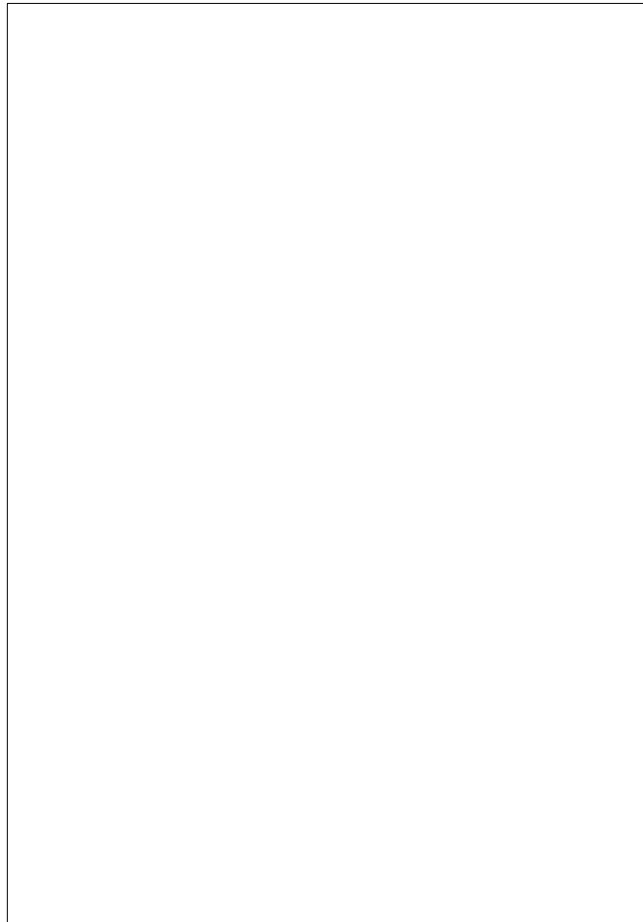
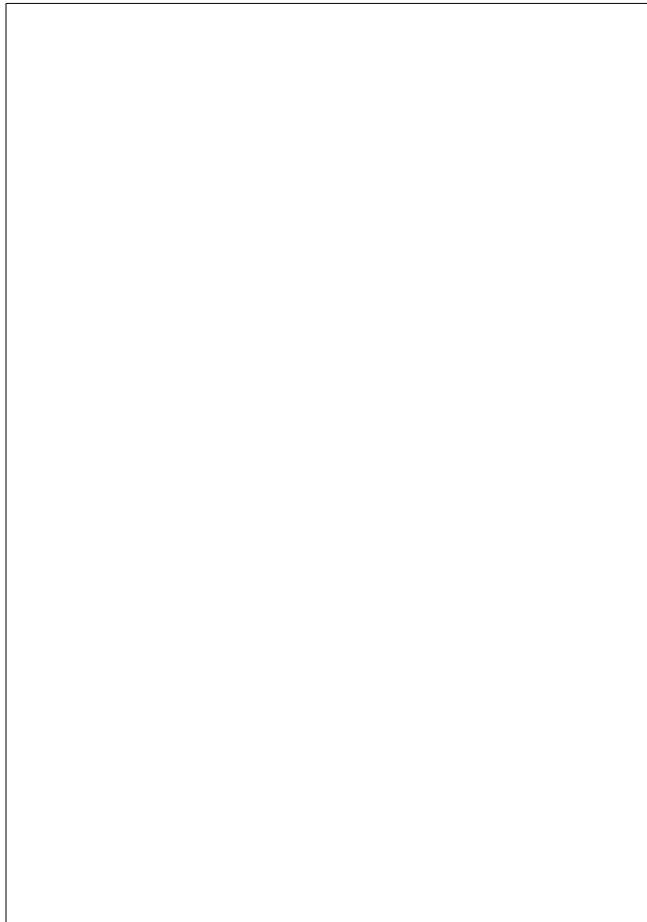



| Scene | Duration | Panel | Duration |
|-------|----------|-------|----------|
| 47 | 01:02 | 3 | 00:17 |

| Scene | Duration | Panel | Duration |
|-------|----------|-------|----------|
| 48 | 02:06 | 1 | 00:09 |

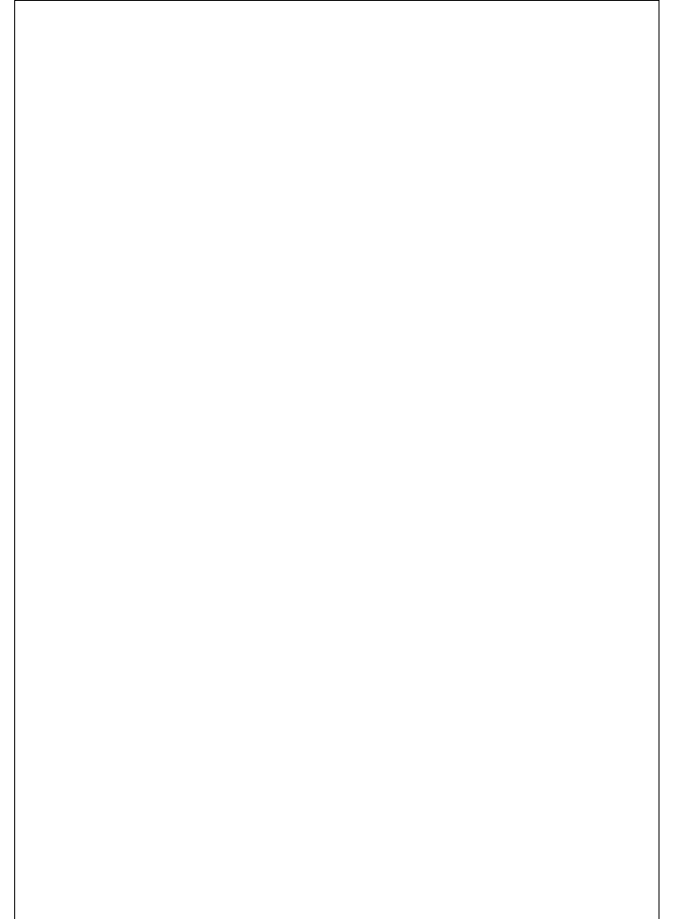
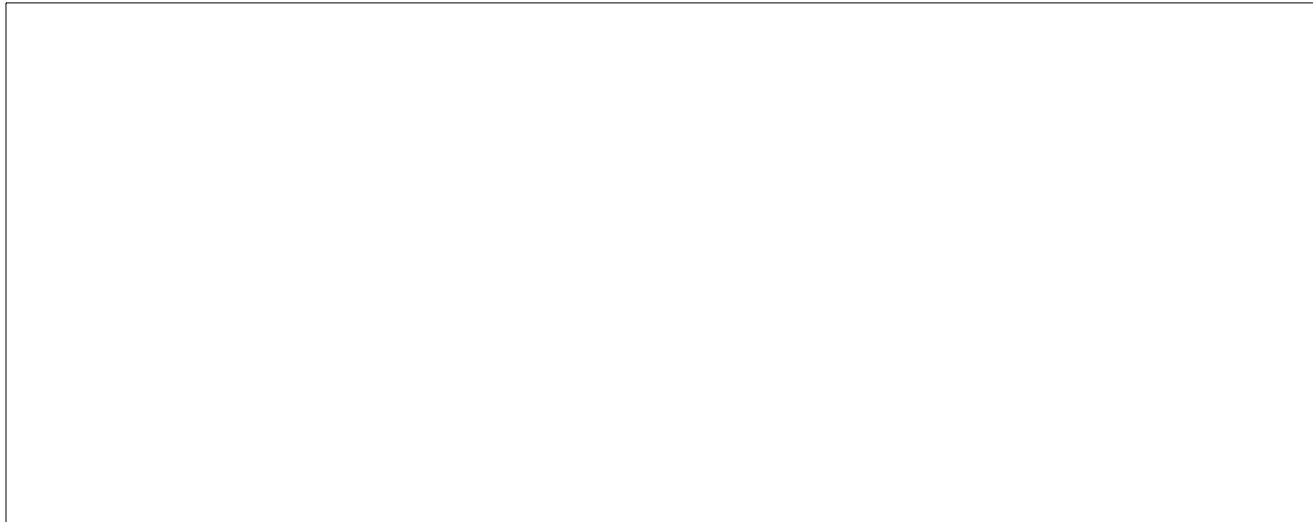
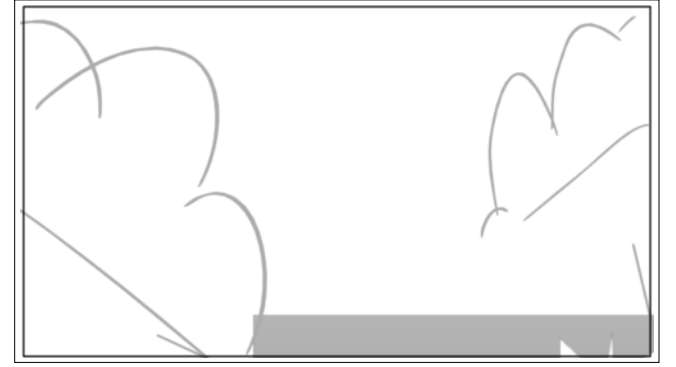
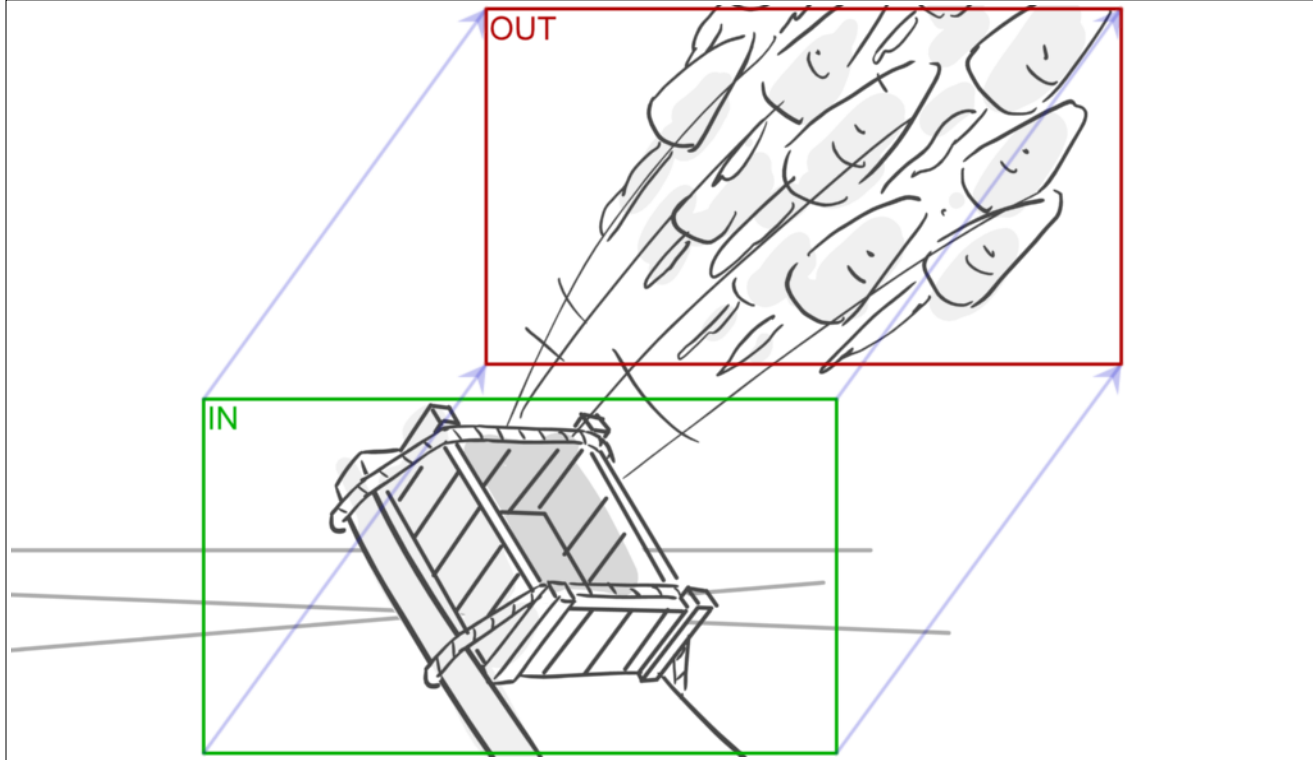

| Scene | Duration | Panel | Duration |
|-------|----------|-------|----------|
| 48 | 02:06 | 2 | 00:15 |



| Scene | Duration | Panel | Duration |
|-------|----------|-------|----------|
| 48 | 02:06 | 3 | 01:07 |

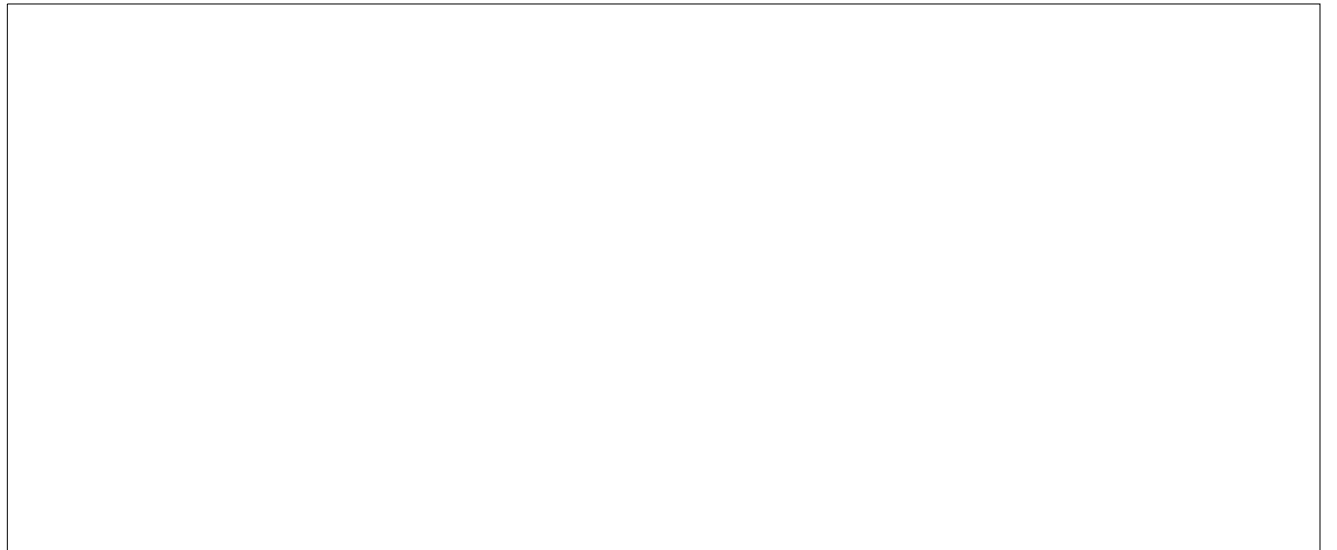
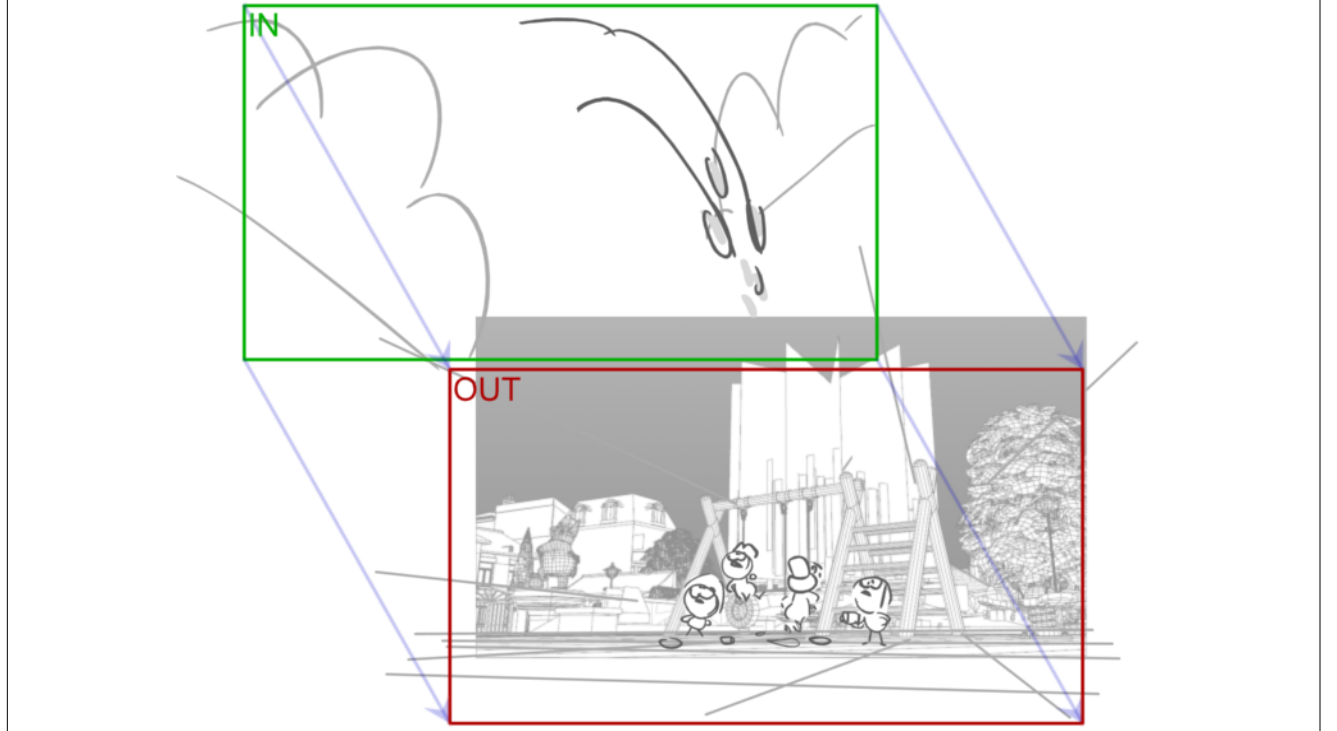

| Scene | Duration | Panel | Duration |
|-------|----------|-------|----------|
| 49 | 02:24 | 1 | 00:15 |



| Scene | Duration | Panel | Duration |
|-------|----------|-------|----------|
| 49 | 02:24 | 2 | 00:08 |

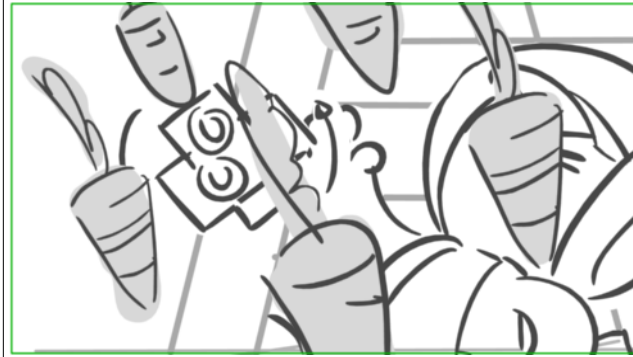

Action Notes

La pluie de carottes déséquilibre VAL qui tombe OUT

| Scene | Duration | Panel | Duration |
|-------|----------|-------|----------|
| 49 | 02:24 | 3 | 00:18 |

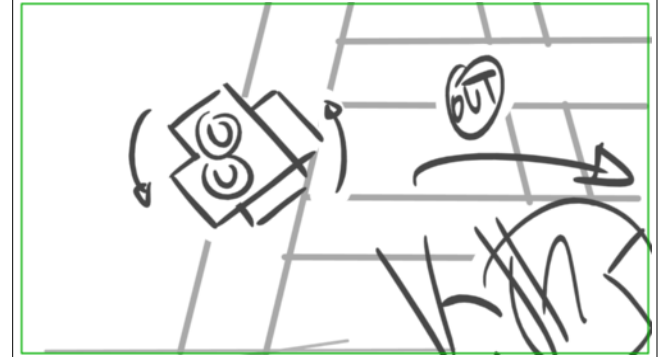



| | | | |
|-------|----------|-------|----------|
| Scene | Duration | Panel | Duration |
| 49 | 02:24 | 4 | 00:08 |

NO PANEL

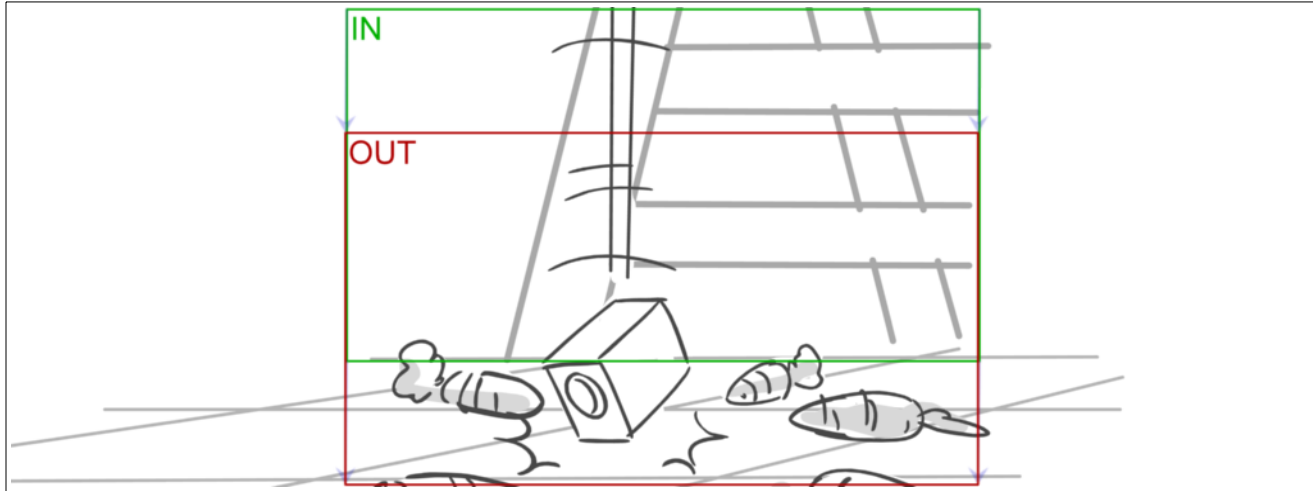

Action Notes
La CAM tombe au sol

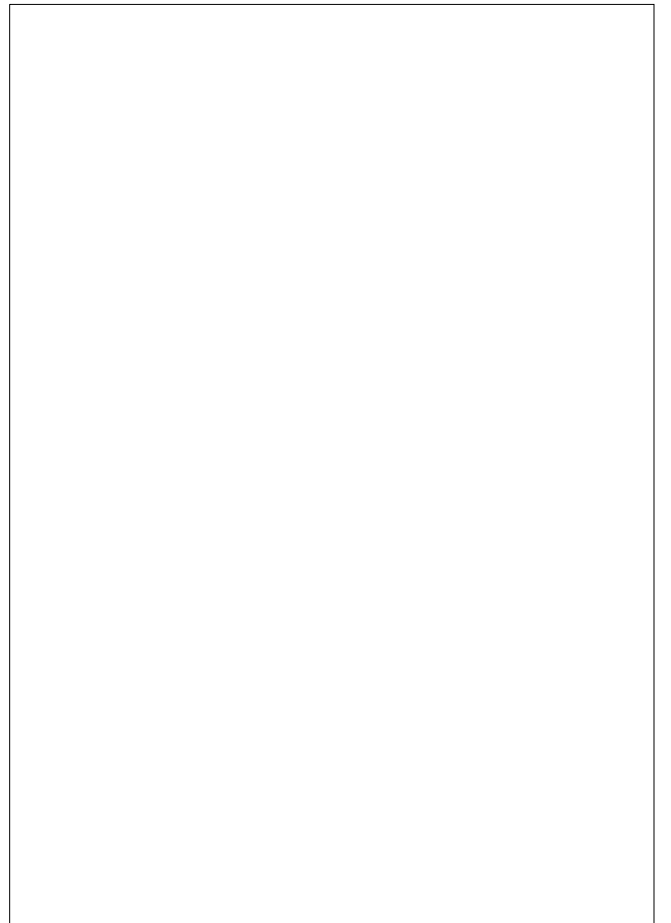
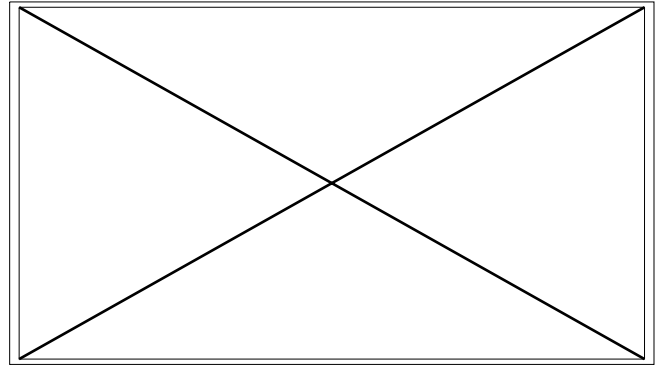

| Scene | Duration | Panel | Duration |
|-------|----------|-------|----------|
| 49 | 02:24 | 5 | 01:00 |

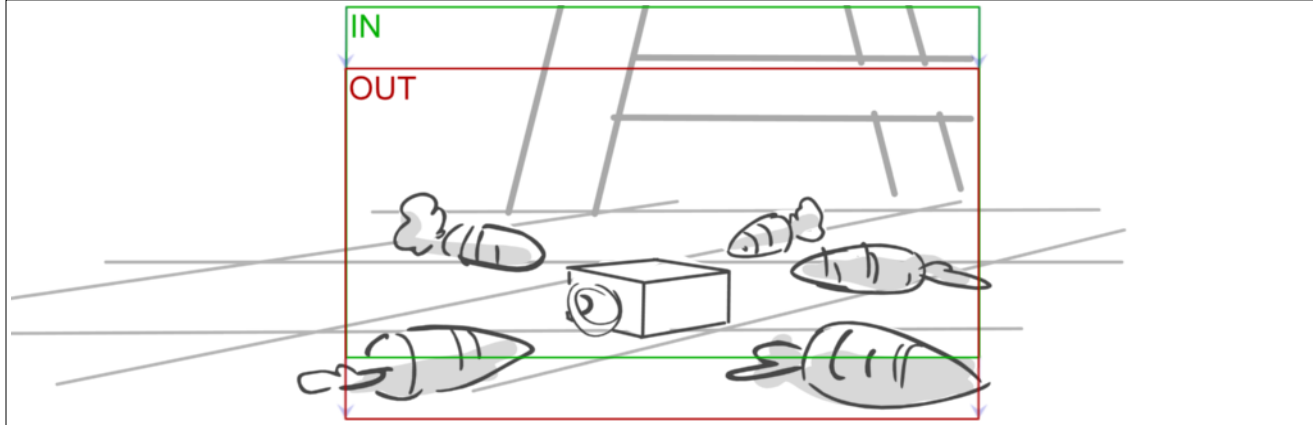

| Scene | Duration | Panel | Duration |
|-------|----------|-------|----------|
| 50 | 05:06 | 1 | 02:03 |



Dialogue

Lapinet
Arf! Arf! Arf!

Action Notes

Les Lapinet se moquent

| Scene | Duration | Panel | Duration |
|-------|----------|-------|----------|
| 50 | 05:06 | 2 | 00:21 |



Dialogue
 PICK UP PIERROT
 Grrr!

| Scene | Duration | Panel | Duration |
|-------|----------|-------|----------|
| 50 | 05:06 | 3 | 00:18 |



Action Notes
 PIERROT IN balnacant des carottes
 ramassées par terre

| Scene | Duration | Panel | Duration |
|-------|----------|-------|----------|
| 50 | 05:06 | 4 | 00:21 |



Dialogue
 PICK UP PIERROT
 Ca va barder pour vos oreilles!

| Scene | Duration | Panel | Duration |
|-------|----------|-------|----------|
| 50 | 05:06 | 5 | 00:18 |

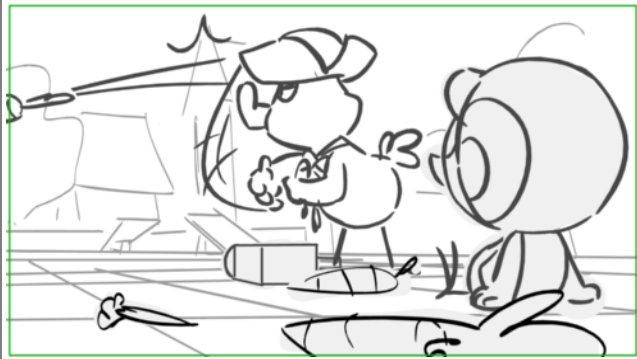

| Scene | Duration | Panel | Duration |
|-------|----------|-------|----------|
| 51 | 03:22 | 1 | 00:13 |

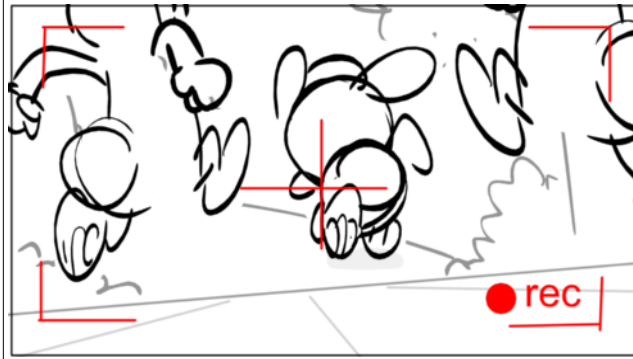

Action Notes
 POV CAM de VAL au sol: Les LAPINETS s'enfuient

| Scene | Duration | Panel | Duration |
|-------|----------|-------|----------|
| 51 | 03:22 | 2 | 00:14 |

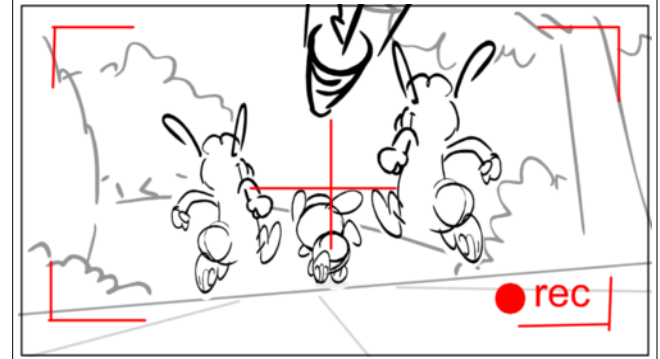



| Scene | Duration | Panel | Duration |
|-------|----------|-------|----------|
| 51 | 03:22 | 3 | 00:13 |

| Scene | Duration | Panel | Duration |
|-------|----------|-------|----------|
| 51 | 03:22 | 4 | 00:14 |

| Scene | Duration | Panel | Duration |
|-------|----------|-------|----------|
| 51 | 03:22 | 5 | 00:11 |

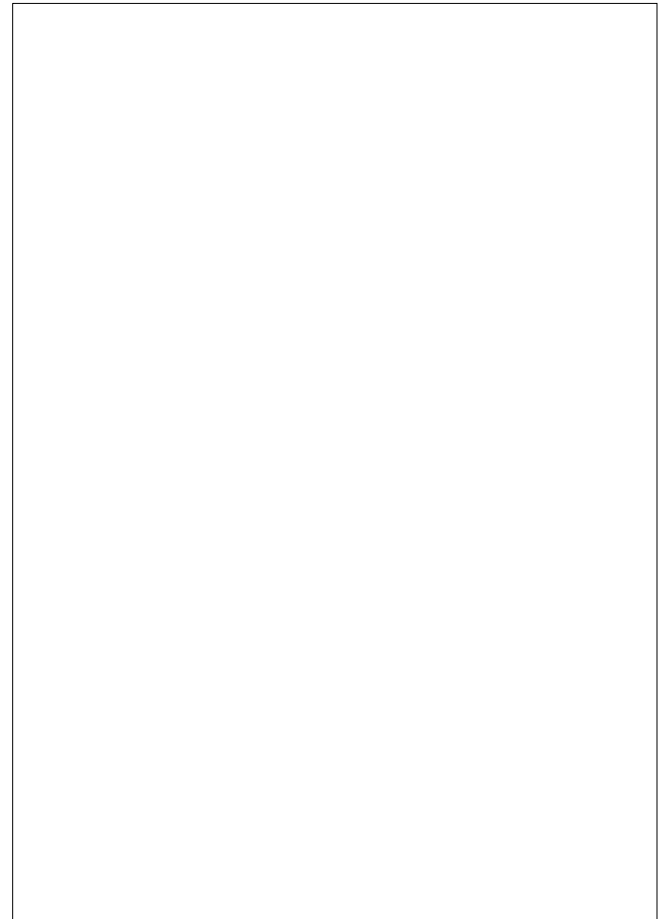
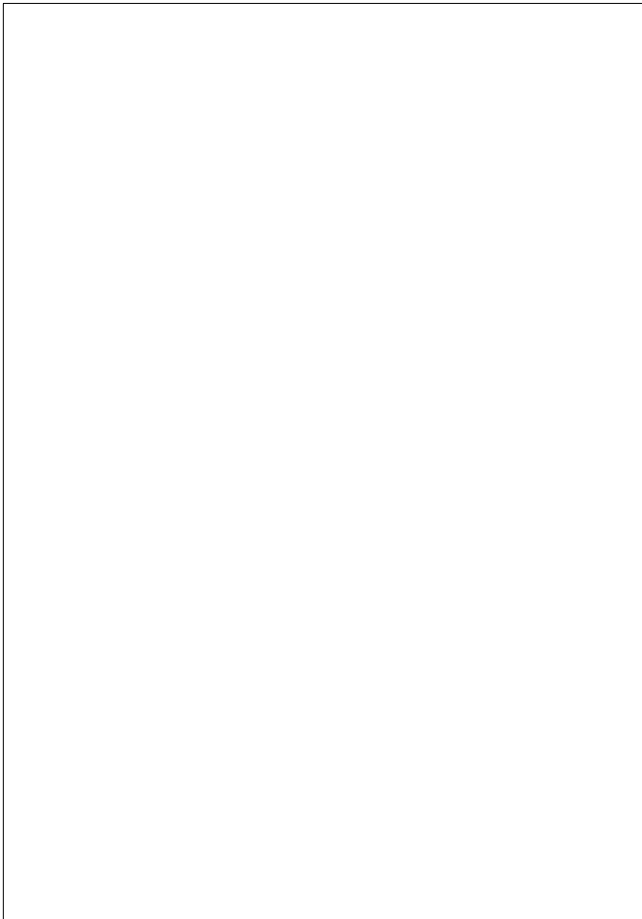
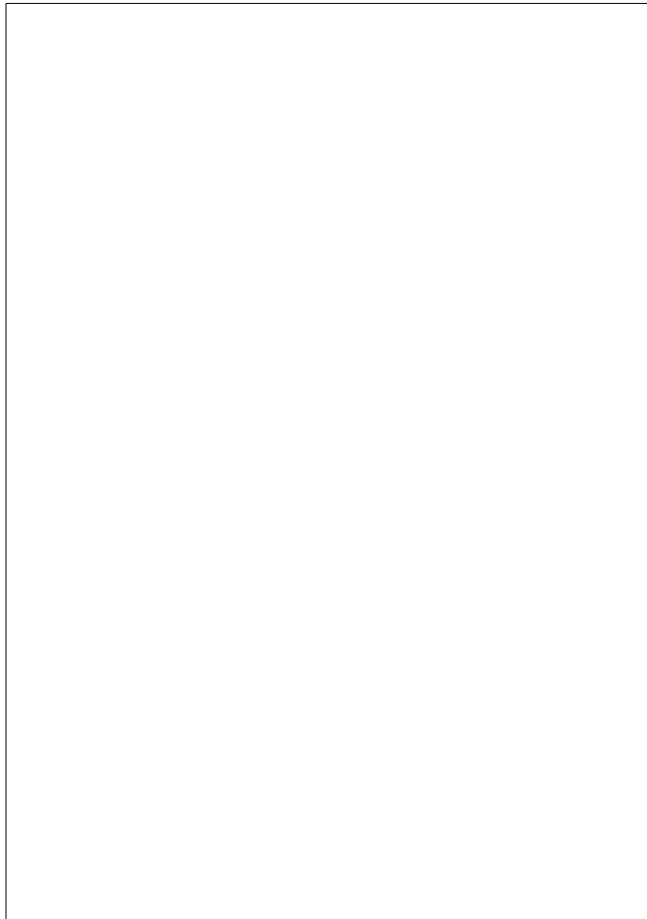
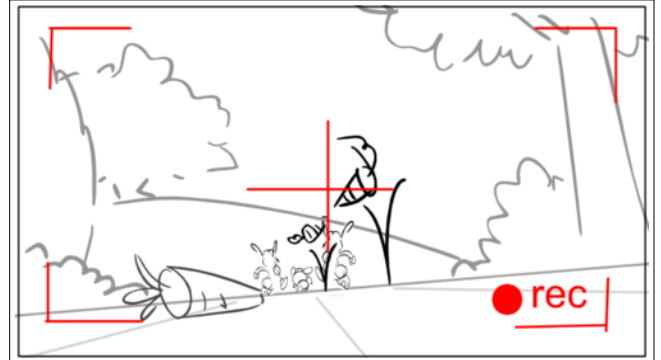
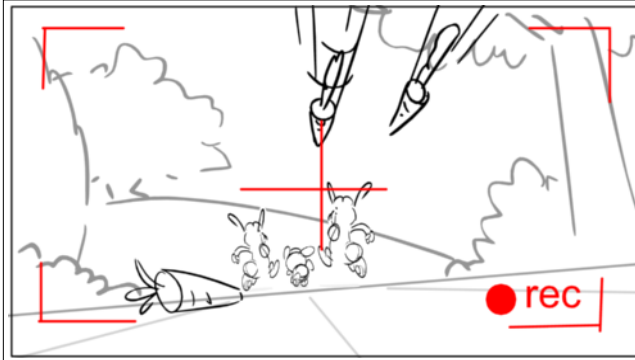
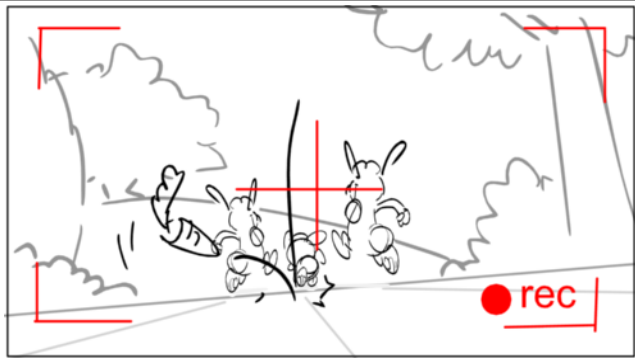

| Scene | Duration | Panel | Duration |
|-------|----------|-------|----------|
| 51 | 03:22 | 6 | 01:07 |

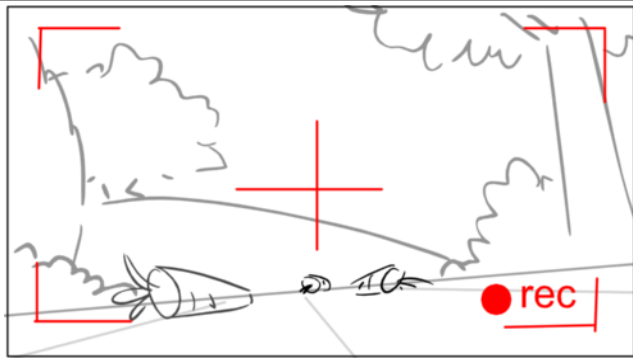

| Scene | Duration | Panel | Duration |
|-------|----------|-------|----------|
| 52 | 12:02 | 1 | 02:22 |



Dialogue

34. PIERROT
Allez jouer ailleurs bande de nazebrocks!

| Scene | Duration | Panel | Duration |
|-------|----------|-------|----------|
| 52 | 12:02 | 2 | 00:13 |

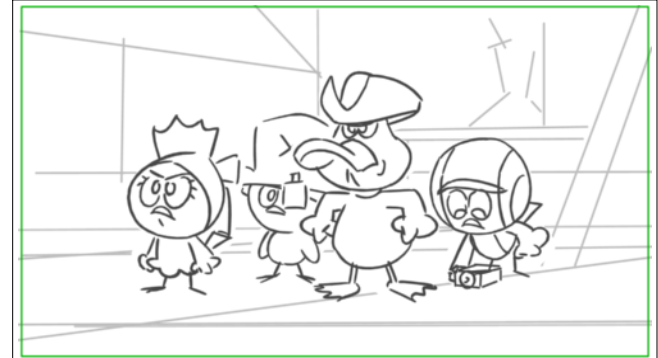

Action Notes

VAL ramasse sa cam

| Scene | Duration | Panel | Duration |
|-------|----------|-------|----------|
| 52 | 12:02 | 3 | 01:22 |

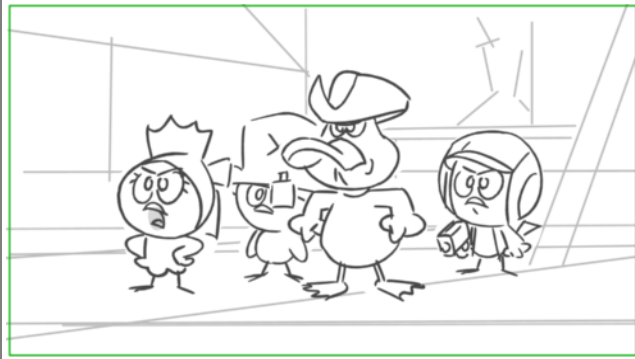

Dialogue

33. PRISCILLA
Ils sont énervants, ceux-là !

| Scene | Duration | Panel | Duration |
|-------|----------|-------|----------|
| 52 | 12:02 | 4 | 01:06 |

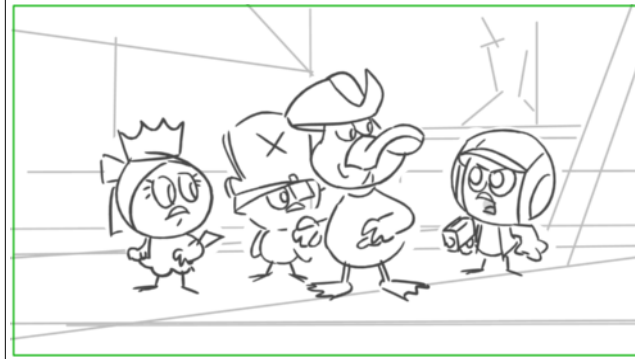

Dialogue

41. VALERIANO MODIF
Pas de temps à perdre! Venez!

| Scene | Duration | Panel | Duration |
|-------|----------|-------|----------|
| 52 | 12:02 | 5 | 01:22 |

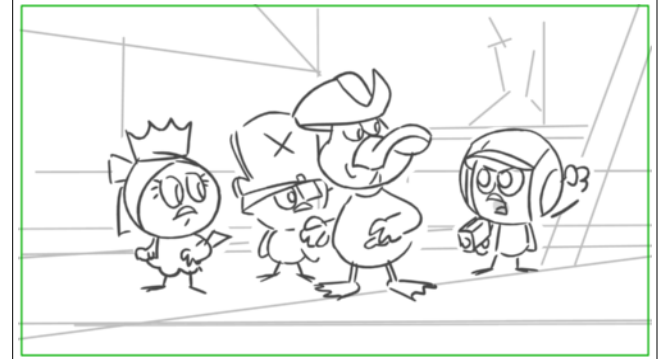

Dialogue

41. VALERIANO MODIF
! Venez!

| Scene | Duration | Panel | Duration |
|-------|----------|-------|----------|
| 52 | 12:02 | 6 | 01:00 |

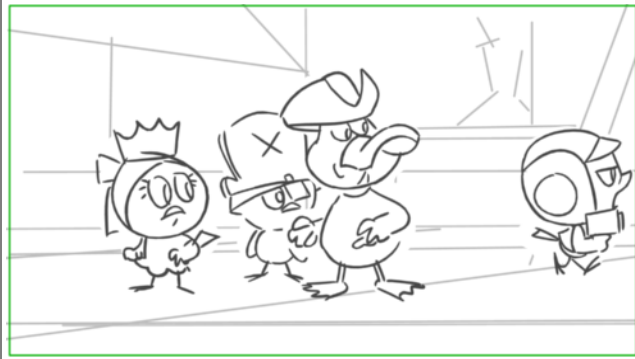

Dialogue

41. VALERIANO
on va tourner le grand duel du
Capitaine corsaire

| Scene | Duration | Panel | Duration |
|-------|----------|-------|----------|
| 52 | 12:02 | 7 | 01:03 |

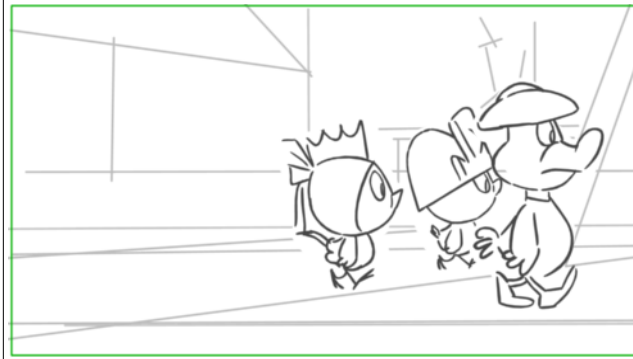

Dialogue

41. VALERIANO
et de son équipière flibustière contre
le méchant pirate !

| Scene | Duration | Panel | Duration |
|-------|----------|-------|----------|
| 52 | 12:02 | 8 | 01:14 |

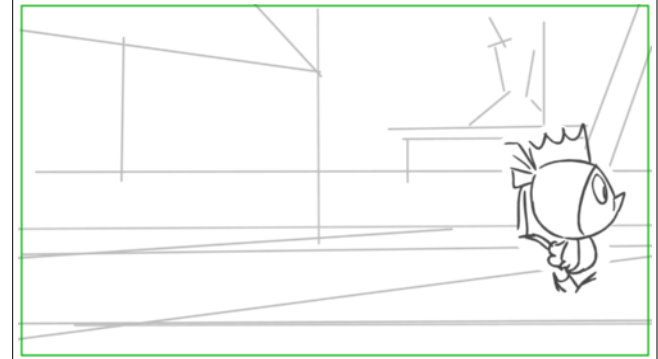

Dialogue

41. VALERIANO
et de son équipière flibustière contre
le méchant pirate !

| Scene | Duration | Panel | Duration |
|-------|----------|-------|----------|
| 53 | 02:19 | 1 | 02:19 |

| Scene | Duration | Panel | Duration |
|-------|----------|-------|----------|
| 54 | 04:00 | 1 | 00:10 |

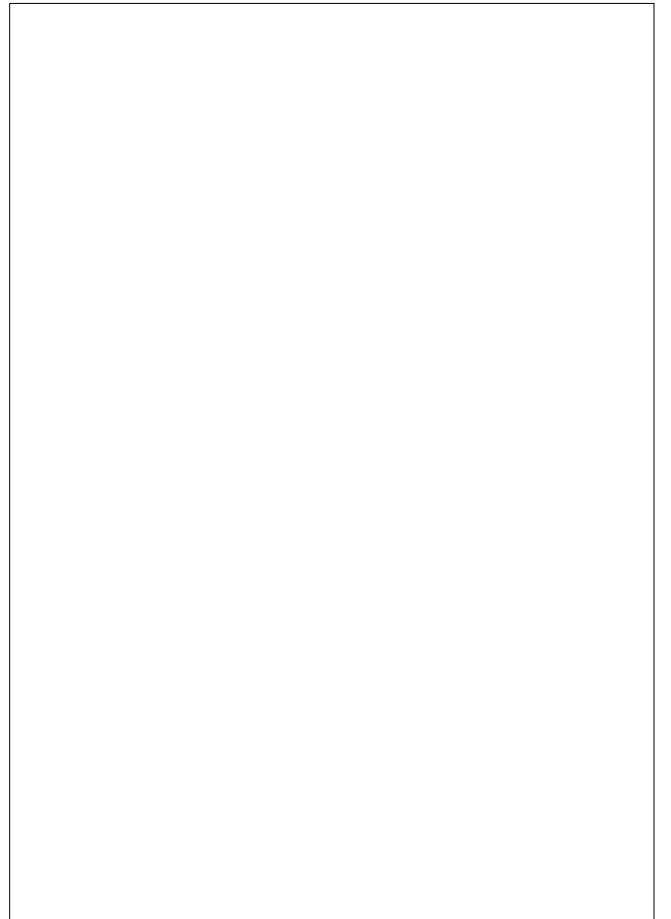
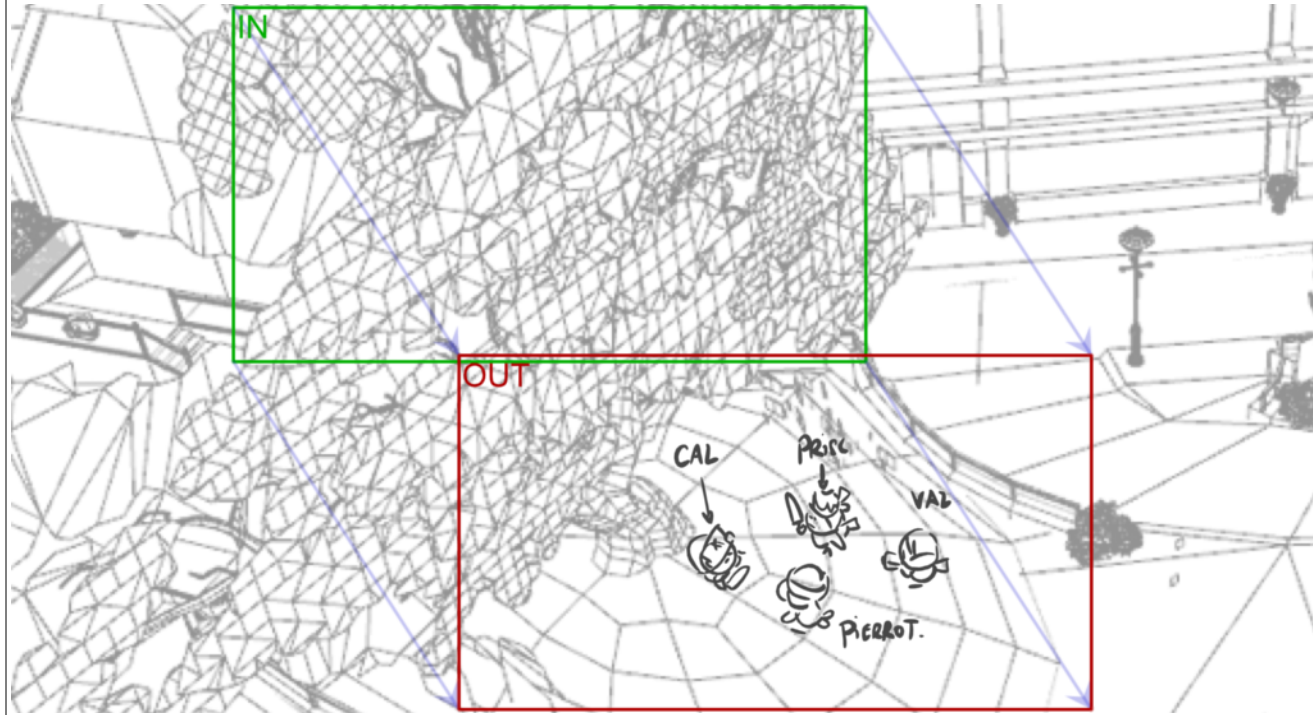

Dialogue
 42. VALERIANO (l'œil rivé à la caméra)
 Ça tourne ! Action !

Action Notes
 6. PARC ? PRES DU CERISIER / EXT. JOUR / SCENE 3 DU FILM DE VALERIANO

| Scene | Duration | Panel | Duration |
|-------|----------|-------|----------|
| 54 | 04:00 | 2 | 00:24 |

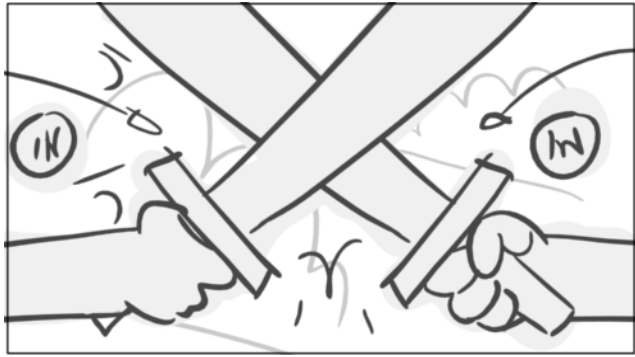

| Scene | Duration | Panel | Duration |
|-------|----------|-------|----------|
| 54 | 04:00 | 3 | 00:10 |



| Scene | Duration | Panel | Duration |
|-------|----------|-------|----------|
| 54 | 04:00 | 4 | 01:00 |

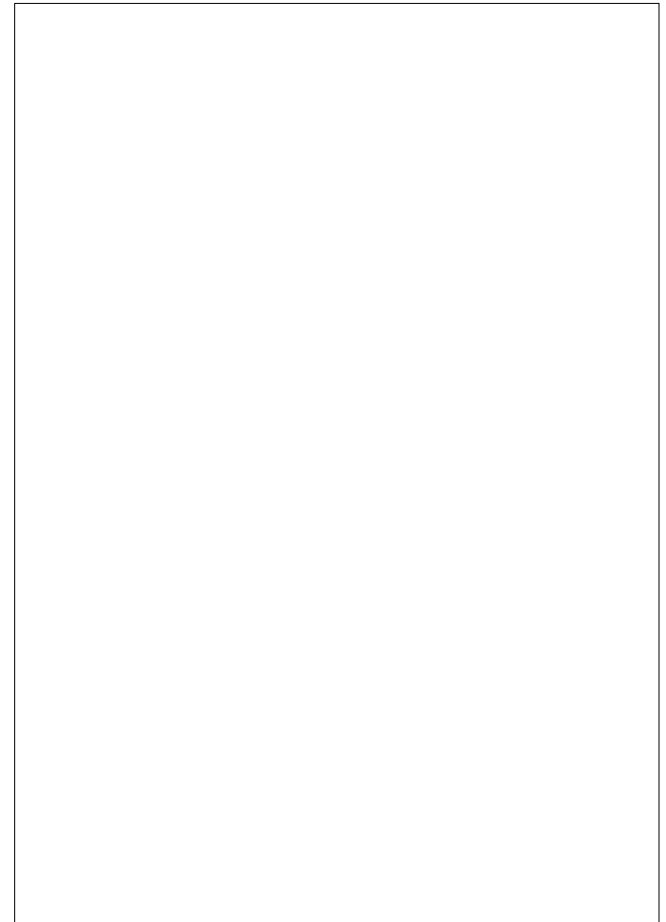
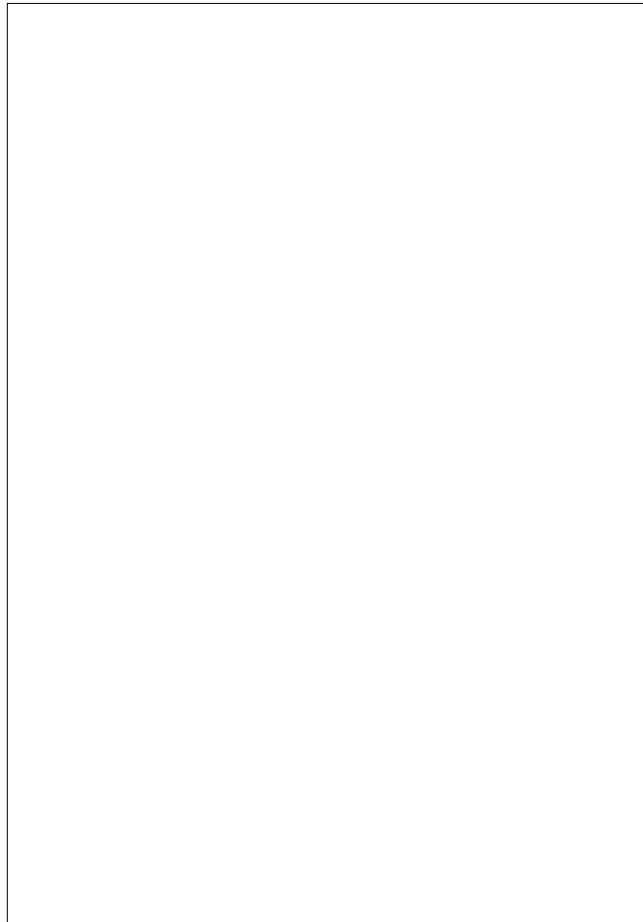
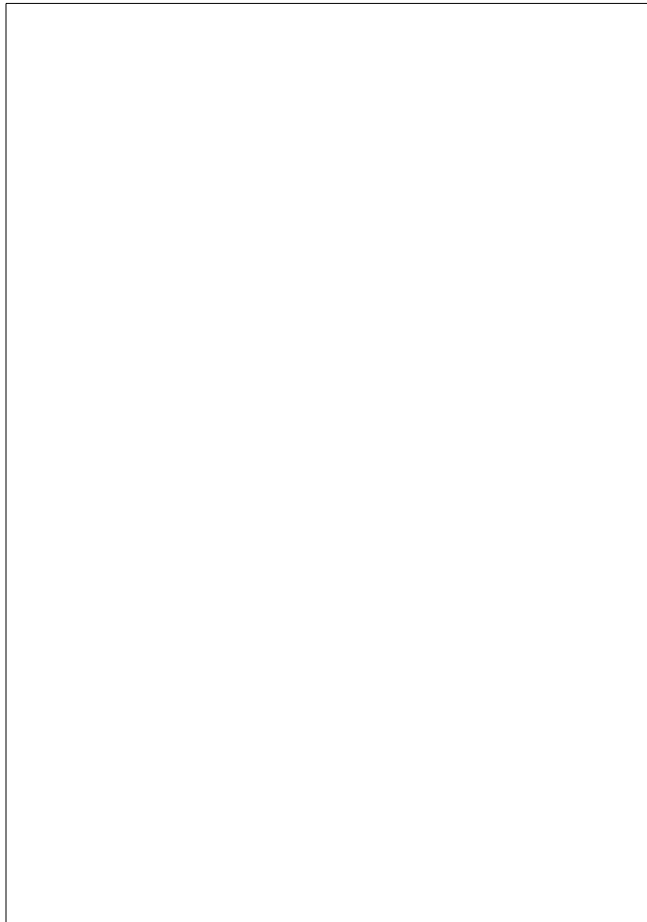

| Scene | Duration | Panel | Duration |
|-------|----------|-------|----------|
| 54 | 04:00 | 5 | 00:09 |



Dialogue

)

| Scene | Duration | Panel | Duration |
|-------|----------|-------|----------|
| 54 | 04:00 | 6 | 00:11 |



Dialogue

43. PRISCILLA (brandissant son sabre
jouet, à Caliméro)
Tu es fait, Blanc-bec !

| Scene | Duration | Panel | Duration |
|-------|----------|-------|----------|
| 54 | 04:00 | 7 | 00:11 |



Dialogue

43. PRISCILLA (brandissant son sabre
jouet, à Caliméro)
Tu es fait, Blanc-bec !

| Scene | Duration | Panel | Duration |
|-------|----------|-------|----------|
| 55 | 07:01 | 1 | 00:10 |

| Scene | Duration | Panel | Duration |
|-------|----------|-------|----------|
| 55 | 07:01 | 2 | 00:09 |

| Scene | Duration | Panel | Duration |
|-------|----------|-------|----------|
| 55 | 07:01 | 3 | 01:00 |

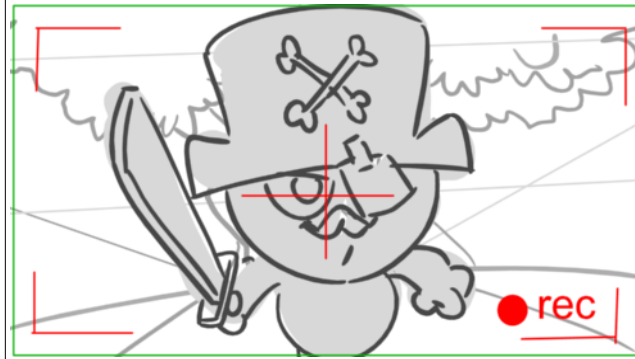
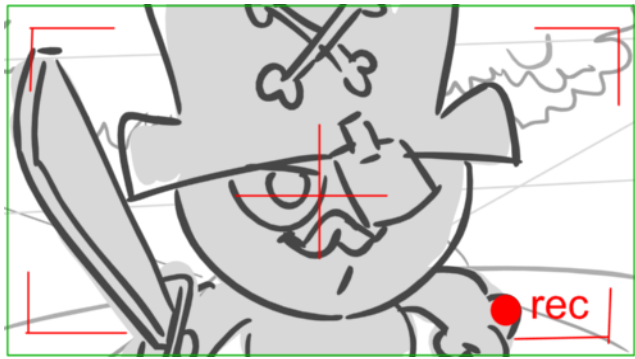

Dialogue
 43. PRISCILLA (brandissant son sabre jouet, à Caliméro)
 Rends-toi !

| Scene | Duration | Panel | Duration |
|-------|----------|-------|----------|
| 55 | 07:01 | 4 | 00:09 |

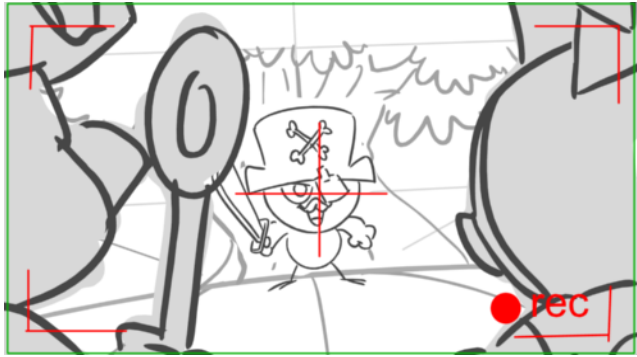

Dialogue
 45. CALIMERO (jouant le pirate perfide)
 Ah Aaah !

| Scene | Duration | Panel | Duration |
|-------|----------|-------|----------|
| 55 | 07:01 | 5 | 01:02 |

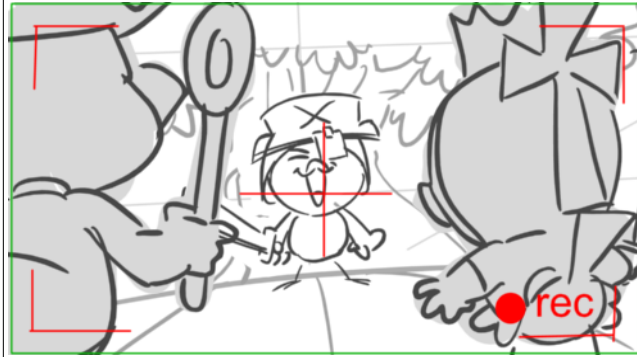

Dialogue
 45. CALIMERO (jouant le pirate perfide)
 Ah Aaah !

| Scene | Duration | Panel | Duration |
|-------|----------|-------|----------|
| 55 | 07:01 | 6 | 03:21 |

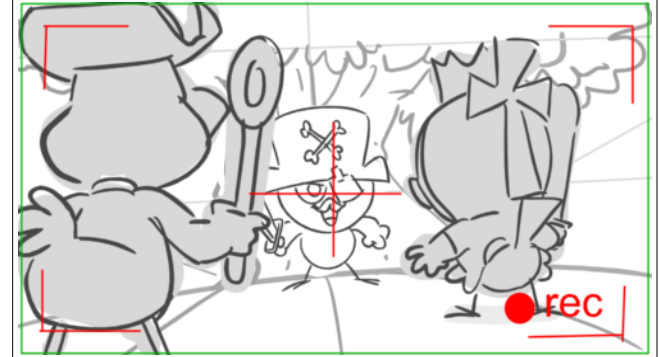

Dialogue
 45. CALIMERO (jouant le pirate perfide)
 Pauvres mollusques d'eau douce !

| Scene | Duration | Panel | Duration |
|-------|----------|-------|----------|
| 56 | 06:08 | 1 | 01:24 |



Dialogue

45. CALIMERO (jouant le pirate perfide)
Venez tâtez de mon sabre d'abord !

| Scene | Duration | Panel | Duration |
|-------|----------|-------|----------|
| 56 | 06:08 | 2 | 01:17 |



Dialogue

45. CALIMERO (jouant le pirate perfide)
Venez tâtez de mon sabre d'abord !

Action Notes

Les lapinets passent en douce derrière Valeriano

| Scene | Duration | Panel | Duration |
|-------|----------|-------|----------|
| 56 | 06:08 | 3 | 01:00 |



Dialogue

44. PIERROT (brandissant une cuillère en bois, à Caliméro)
Espèce de pirate moisi du mât !

| Scene | Duration | Panel | Duration |
|-------|----------|-------|----------|
| 56 | 06:08 | 4 | 01:17 |



Dialogue

44. PIERROT (brandissant une cuillère en bois, à Caliméro)
Espèce de pirate moisi du mât !

| Scene | Duration | Panel | Duration |
|-------|----------|-------|----------|
| 57 | 13:18 | 1 | 00:24 |

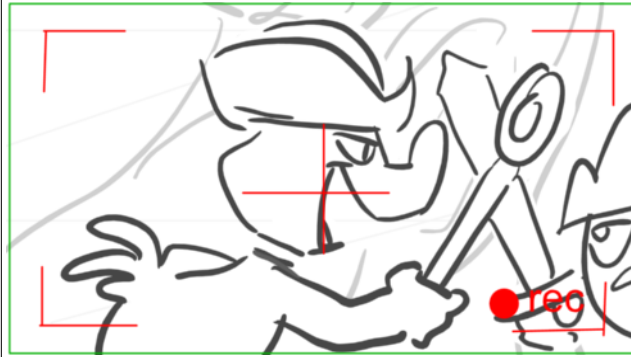

Dialogue

44. PIERROT (brandissant une cuillère en bois, à Caliméro)
Tu vas payer pour avoir pillé tous les bonbons du Pacifique !

| Scene | Duration | Panel | Duration |
|-------|----------|-------|----------|
| 57 | 13:18 | 2 | 01:00 |

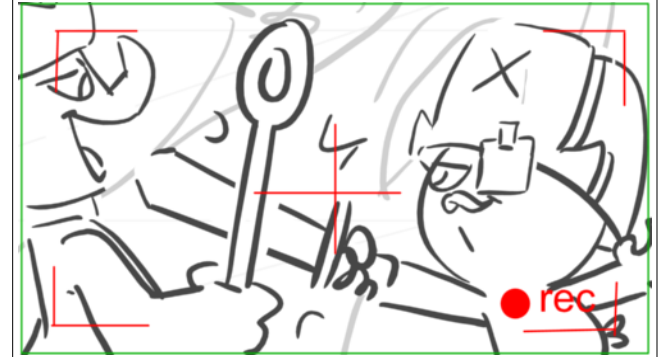

Dialogue

44. PIERROT (brandissant une cuillère en bois, à Caliméro)
Tu vas payer pour avoir pillé tous les bonbons du Pacifique !

| Scene | Duration | Panel | Duration |
|-------|----------|-------|----------|
| 57 | 13:18 | 3 | 00:24 |

| Scene | Duration | Panel | Duration |
|-------|----------|-------|----------|
| 57 | 13:18 | 4 | 00:10 |

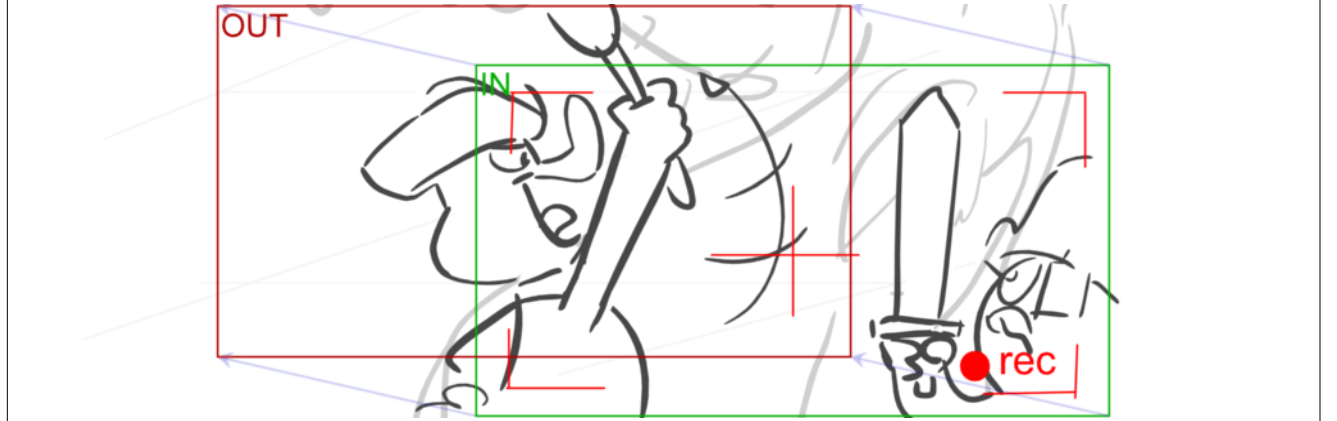
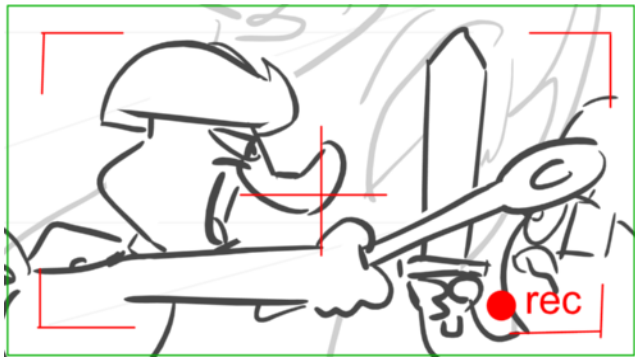

Dialogue

44. PIERROT (brandissant une cuillère en bois, à Caliméro)
 Tu vas payer pour avoir pillé tous les bonbons du Pacifique !

| Scene | Duration | Panel | Duration |
|-------|----------|-------|----------|
| 57 | 13:18 | 5 | 00:07 |

| Scene | Duration | Panel | Duration |
|-------|----------|-------|----------|
| 57 | 13:18 | 6 | 00:07 |

| Scene | Duration | Panel | Duration |
|-------|----------|-------|----------|
| 57 | 13:18 | 7 | 00:15 |

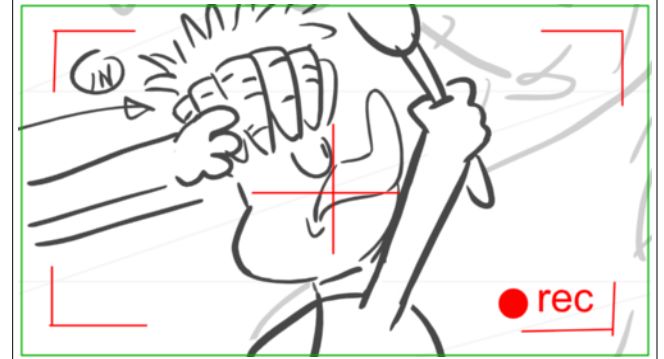
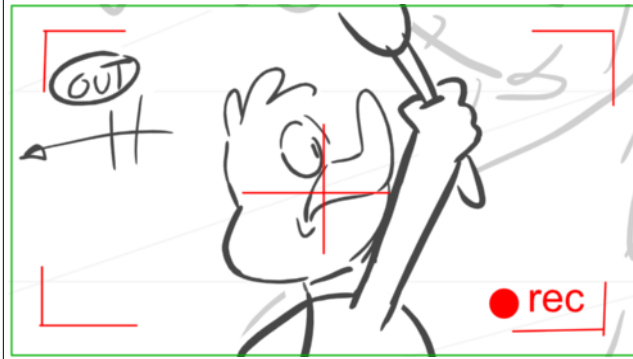
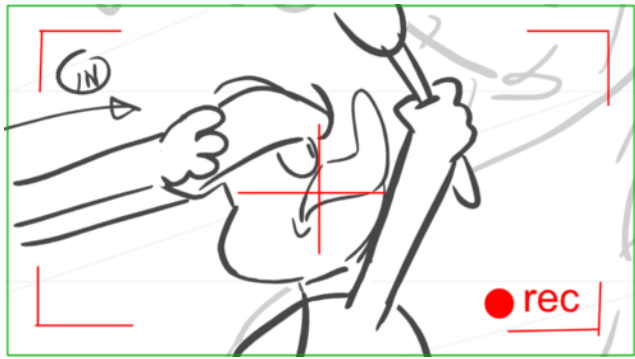

Action Notes

Cot , chipe le tricorne de Pierrot et le remplace furtivement par une couronne de carottes.

| Scene | Duration | Panel | Duration |
|-------|----------|-------|----------|
| 57 | 13:18 | 8 | 01:05 |

| Scene | Duration | Panel | Duration |
|-------|----------|-------|----------|
| 57 | 13:18 | 9 | 01:00 |

NO PANEL

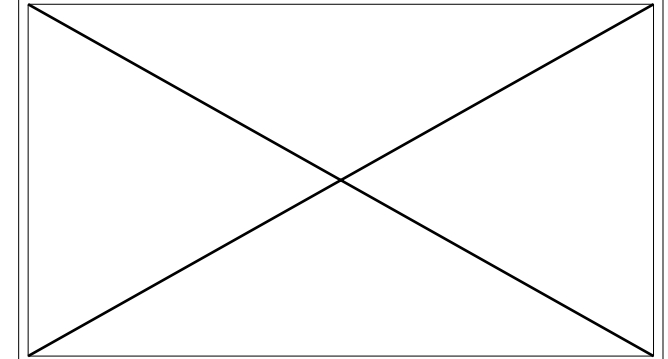
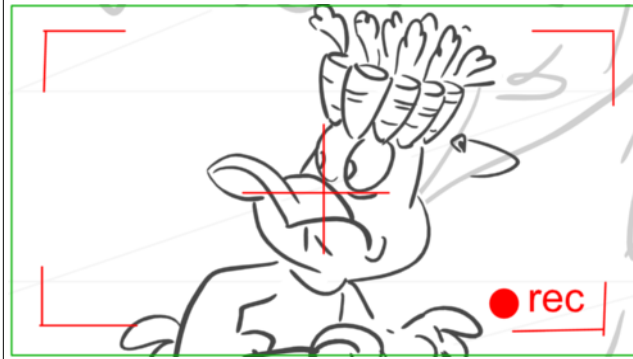
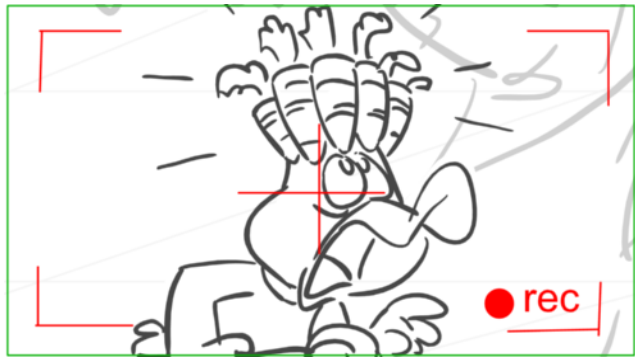

Dialogue
 46. PIERROT (excédé par les Lapinet)
 Hééé !

Dialogue
 47. VALERIANO (criant, hors de lui)
 Coupeeeeez !!!

| Scene | Duration | Panel | Duration |
|-------|----------|-------|----------|
| 57 | 13:18 | 10 | 01:00 |

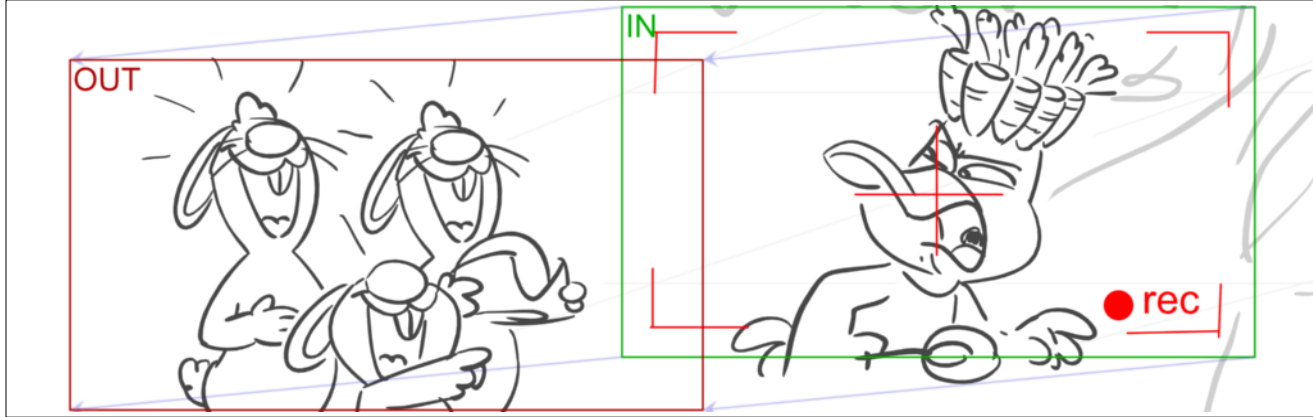

Dialogue

47. PIERROT MODIF (criant, hors de lui)
Grrrr

| Scene | Duration | Panel | Duration |
|-------|----------|-------|----------|
| 57 | 13:18 | 11 | 01:11 |

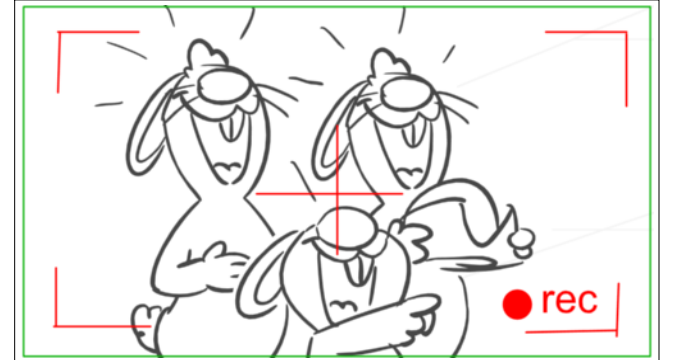

Dialogue

48. POT/COT/MOT (ricanant tout en courant)
Arf ! Arf ! Arf !

| Scene | Duration | Panel | Duration |
|-------|----------|-------|----------|
| 57 | 13:18 | 12 | 01:15 |

| Scene | Duration | Panel | Duration |
|-------|----------|-------|----------|
| 57 | 13:18 | 13 | 01:00 |

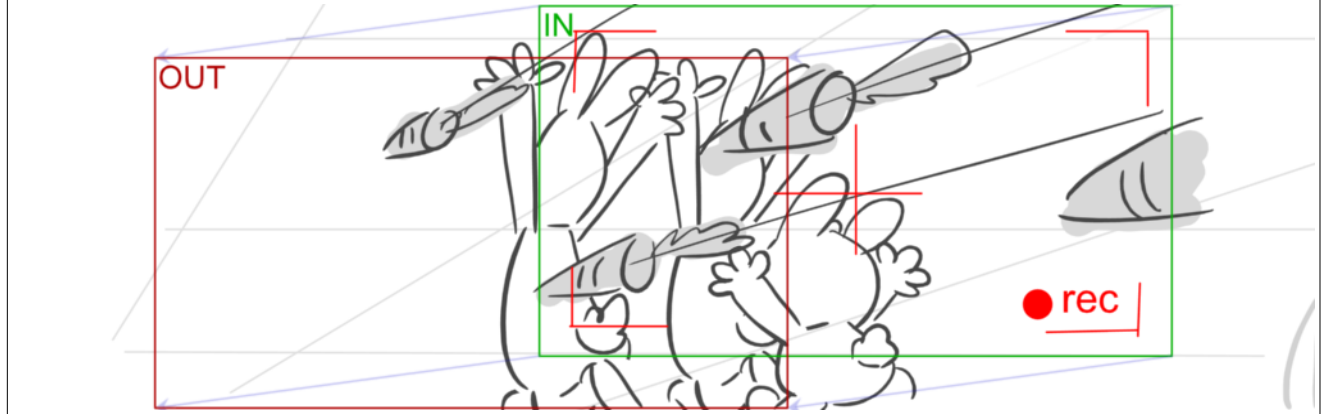
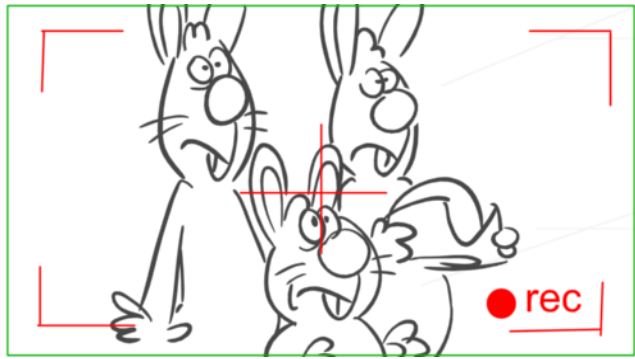

Dialogue
 47. PIERROT (criant, hors de lui)
 vous allez voir ce que vous allez voir !

Dialogue
 49. PIERROT (lançant des carottes en courant)
 Prenez ça !

| Scene | Duration | Panel | Duration |
|-------|----------|-------|----------|
| 57 | 13:18 | 14 | 01:00 |

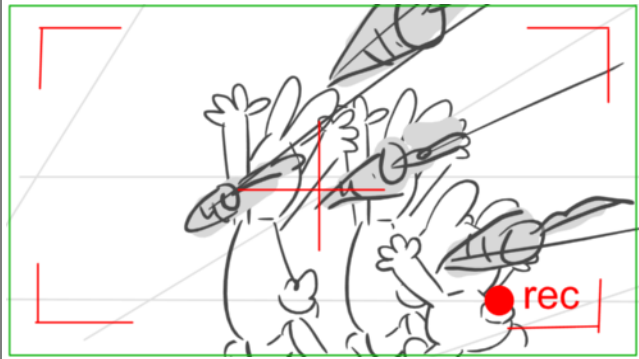

Dialogue

49. PIERROT (lançant des carottes en courant)
Et ça !

| Scene | Duration | Panel | Duration |
|-------|----------|-------|----------|
| 57 | 13:18 | 15 | 01:00 |

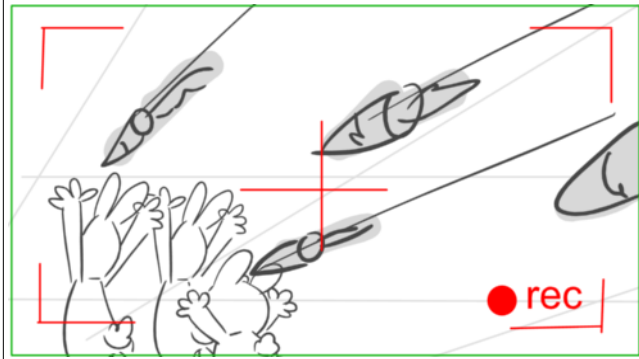

Dialogue

49. PIERROT (lançant des carottes en courant)
Et ça !

| Scene | Duration | Panel | Duration |
|-------|----------|-------|----------|
| 58 | 01:17 | 1 | 00:12 |

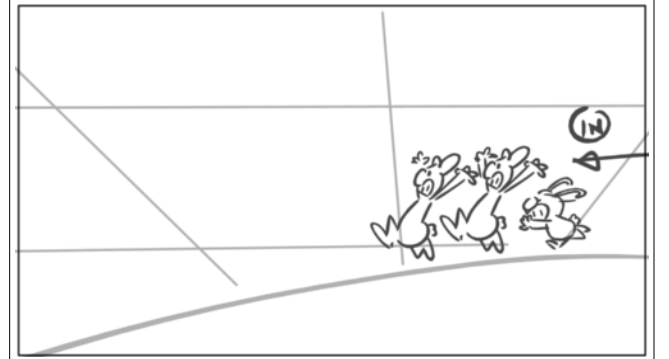

Dialogue

50. POT (sautillant en tendant ses mains en l'air)
Han ! Han !... Héé ! Attendez-moi les cousins !

Action Notes

Les Lapinet sont poursuivis par PIERROT balancant des carottes et Valériano furieux tenant sa caméra (tournant toujours).



| Scene | Duration | Panel | Duration |
|-------|----------|-------|----------|
| 58 | 01:17 | 2 | 00:09 |

| Scene | Duration | Panel | Duration |
|-------|----------|-------|----------|
| 58 | 01:17 | 3 | 00:12 |

| Scene | Duration | Panel | Duration |
|-------|----------|-------|----------|
| 58 | 01:17 | 4 | 00:09 |

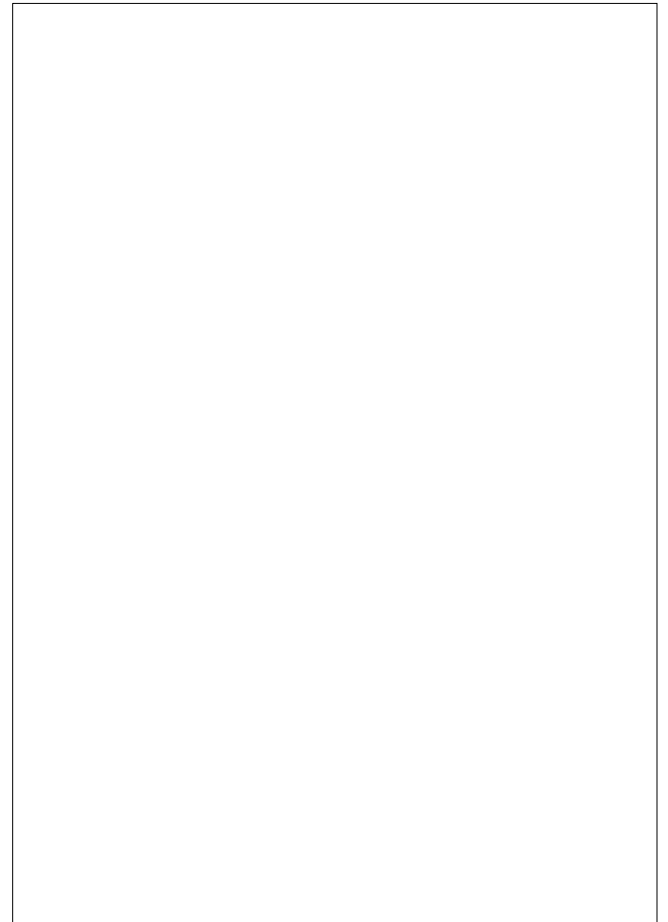
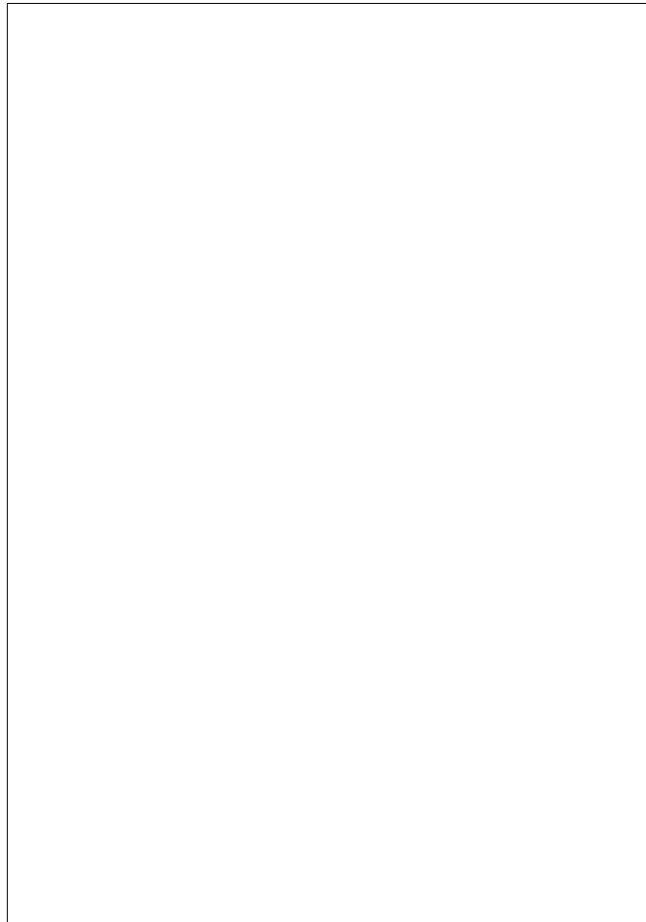
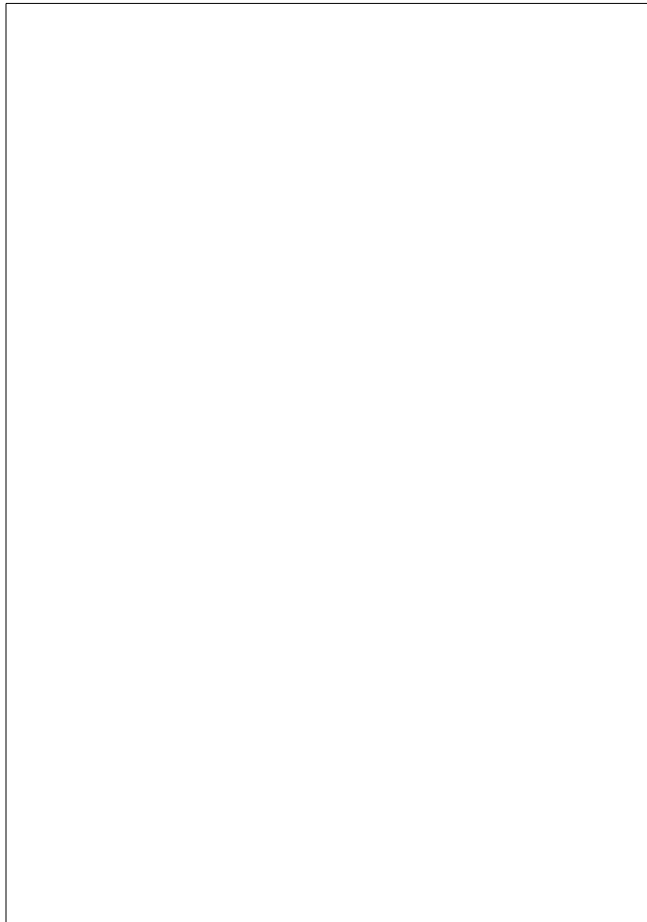
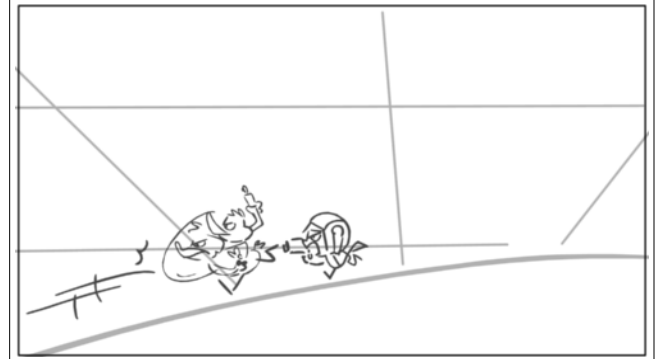
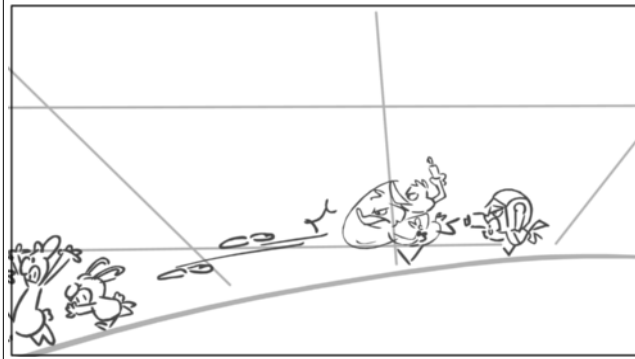
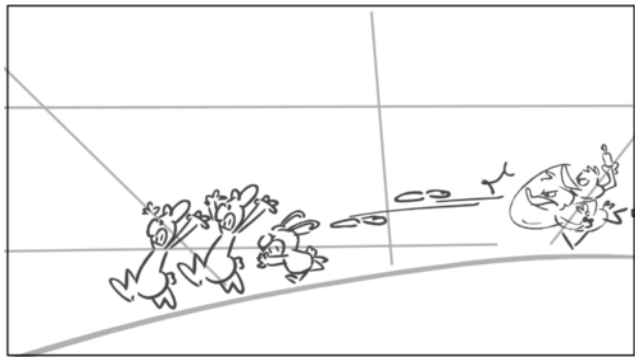

| Scene | Duration | Panel | Duration |
|-------|----------|-------|----------|
| 59 | 05:14 | 1 | 00:13 |



Dialogue

53. PIERROT (jetant ses dernières carottes par-dessus la haie)
Z?êtes les plus moisis des nazbroks-tout-moisiss que j'ai jamais vu !

| Scene | Duration | Panel | Duration |
|-------|----------|-------|----------|
| 59 | 05:14 | 2 | 00:13 |



Dialogue

53. PIERROT (jetant ses dernières carottes par-dessus la haie)
Z?êtes les plus moisis des nazbroks-tout-moisiss que j'ai jamais vu !

| Scene | Duration | Panel | Duration |
|-------|----------|-------|----------|
| 59 | 05:14 | 3 | 00:17 |



Dialogue

53. PIERROT (jetant ses dernières carottes par-dessus la haie)
Z?êtes les plus moisis des nazbroks-tout-moisiss que j'ai jamais vu !

| Scene | Duration | Panel | Duration |
|-------|----------|-------|----------|
| 59 | 05:14 | 4 | 00:11 |



| Scene | Duration | Panel | Duration |
|-------|----------|-------|----------|
| 59 | 05:14 | 5 | 00:16 |



| Scene | Duration | Panel | Duration |
|-------|----------|-------|----------|
| 59 | 05:14 | 6 | 00:16 |



| | | | |
|-------|----------|-------|----------|
| Scene | Duration | Panel | Duration |
| 59 | 05:14 | 7 | 02:03 |

NO PANEL

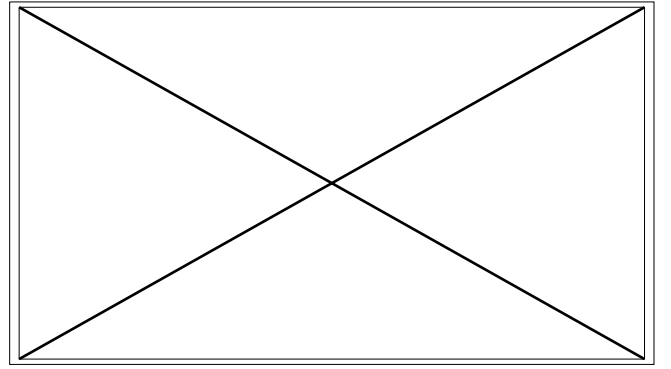
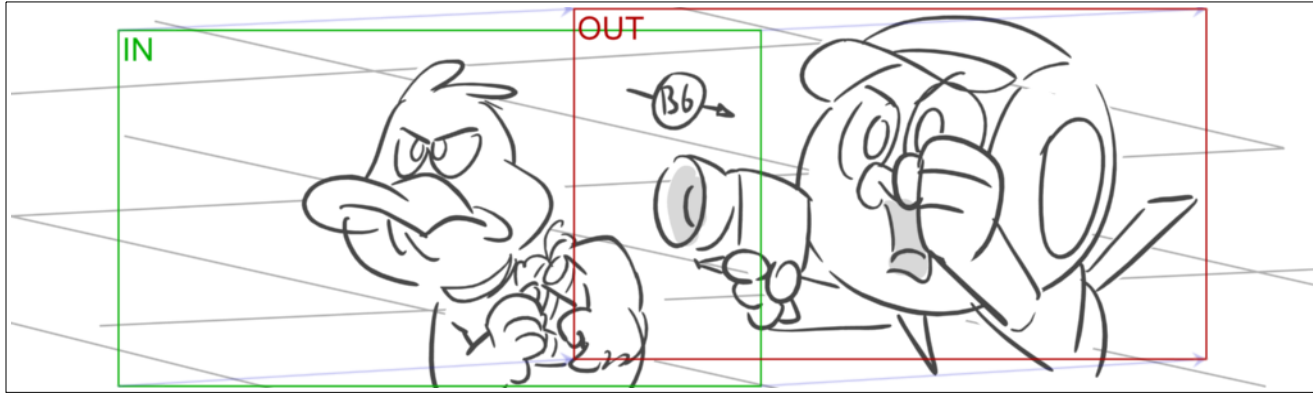

Dialogue
PICK UP VALERIANO
Ca va barder pour vos oreilles les Lapinet!

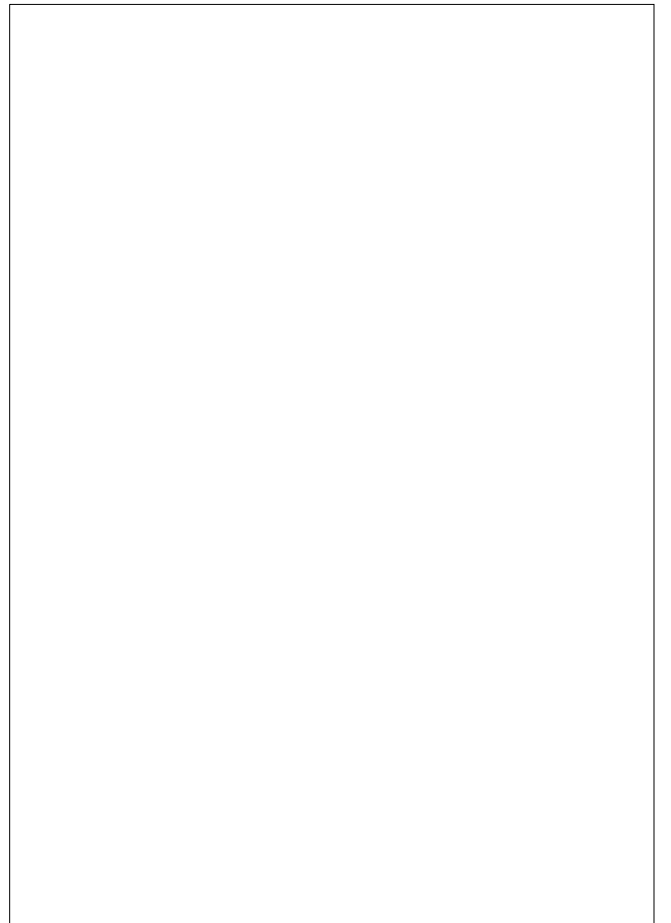



| | | | |
|-------|----------|-------|----------|
| Scene | Duration | Panel | Duration |
| 60 | 07:01 | 1 | 01:01 |

NO PANEL

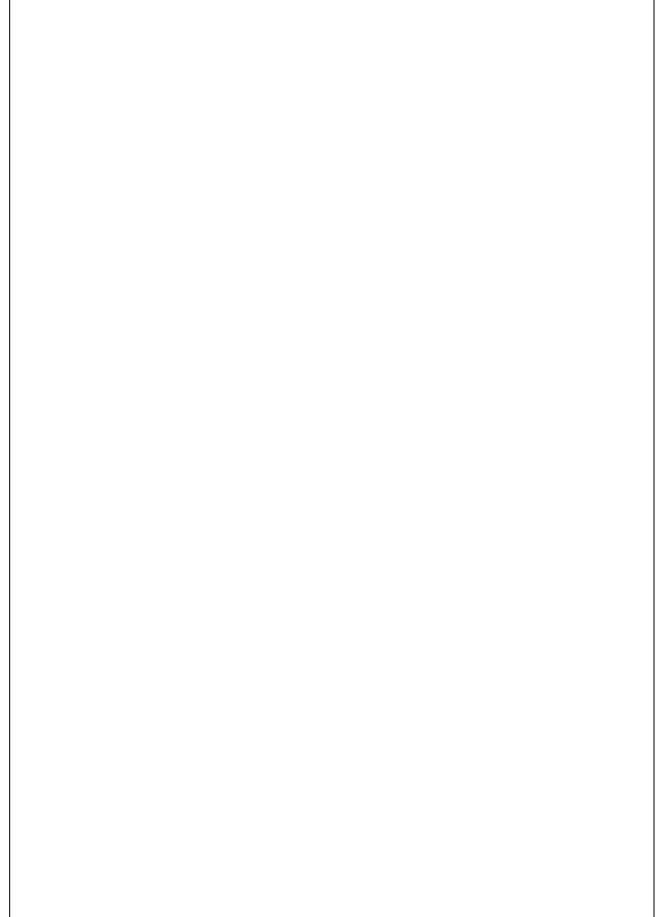
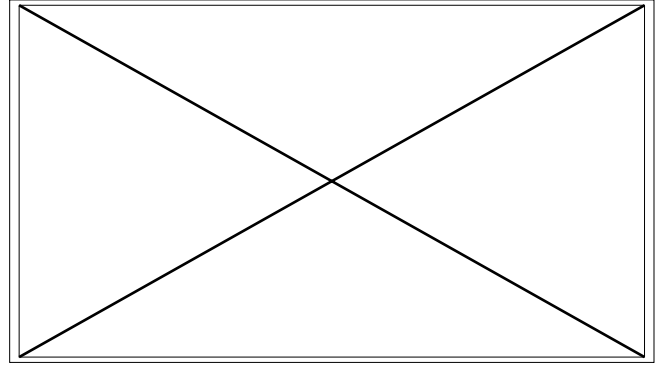
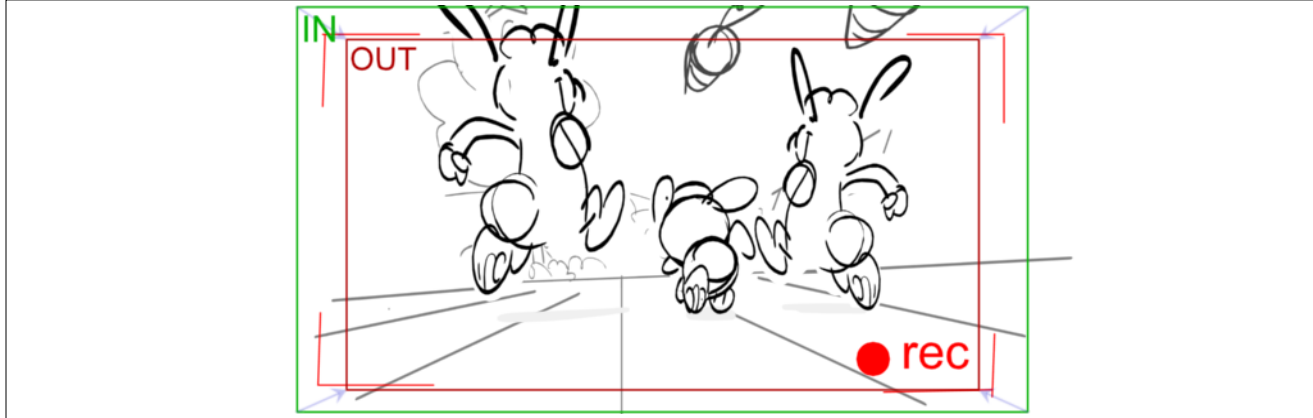



| | | | |
|-------|----------|-------|----------|
| Scene | Duration | Panel | Duration |
| 60 | 07:01 | 2 | 01:07 |

NO PANEL

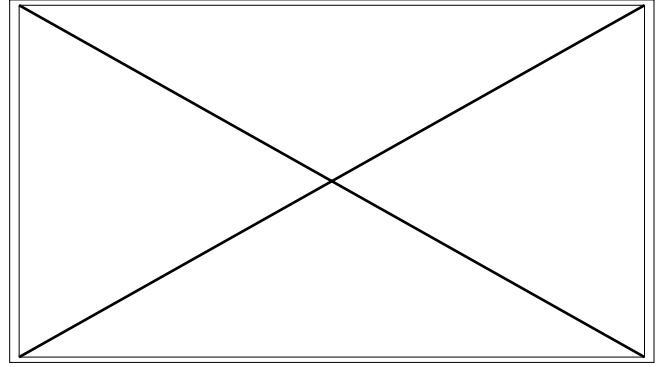
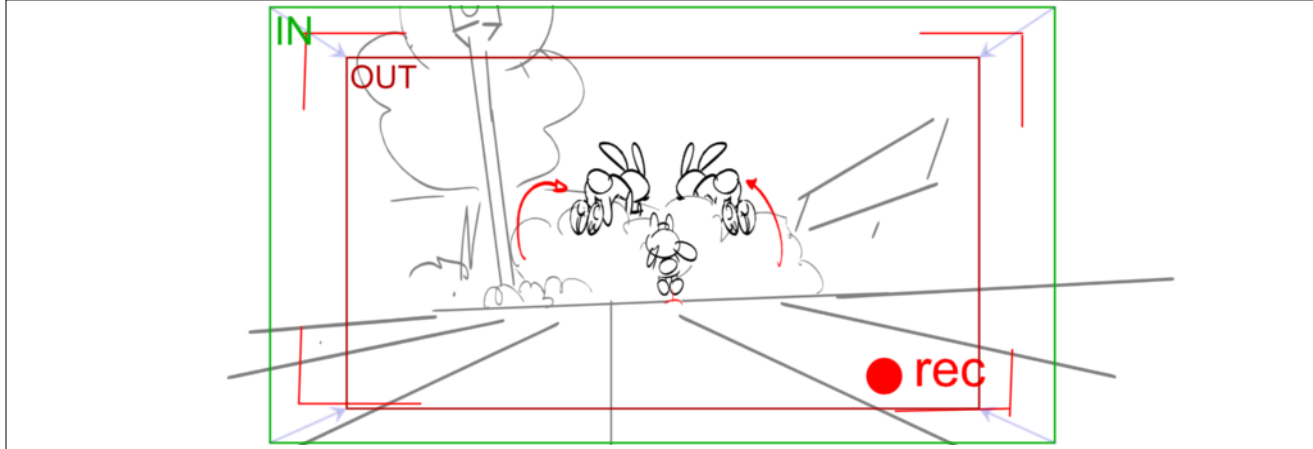

Action Notes

[Cot et Mot sautent par-dessus une rangée de haie touffue pour s'y réfugier et éviter les tirs de carottes.

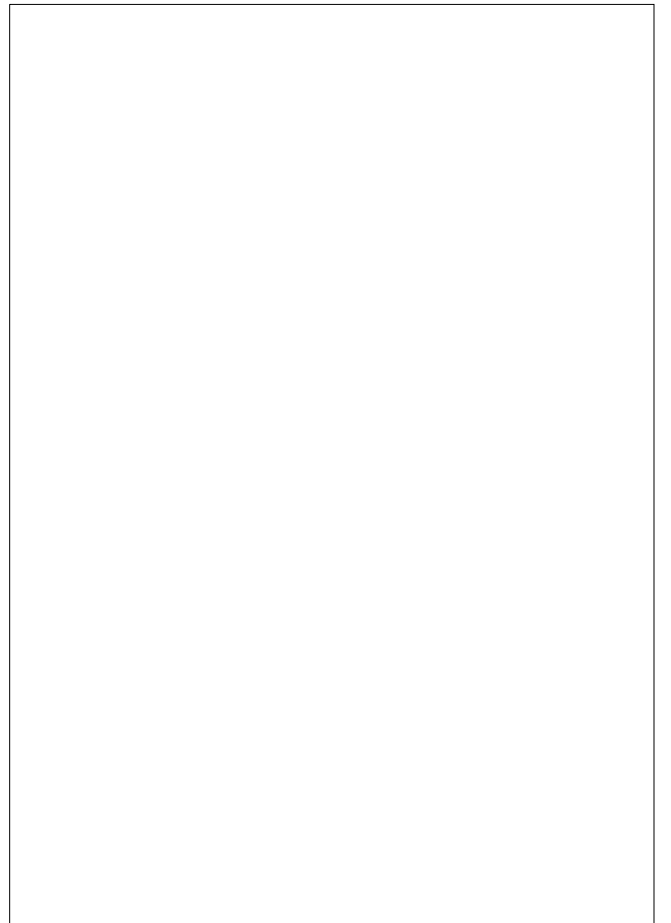

| | | | |
|-------|----------|-------|----------|
| Scene | Duration | Panel | Duration |
| 60 | 07:01 | 3 | 00:16 |

NO PANEL

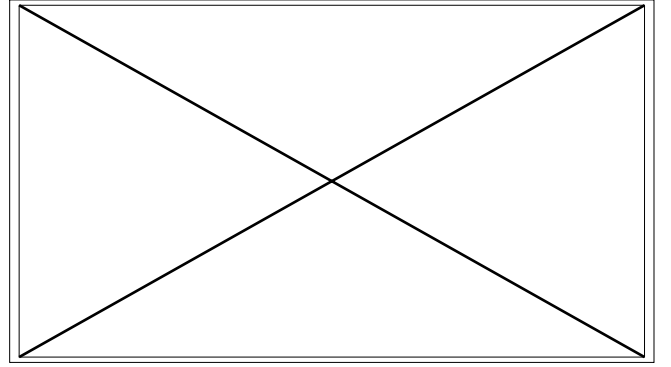
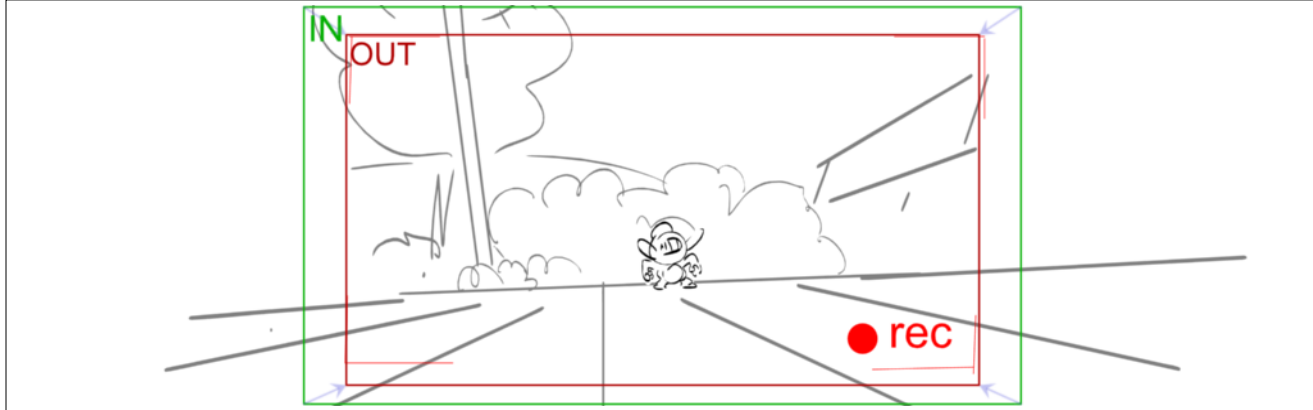

Dialogue
50. POT (sautillant en tendant ses mains en l'air)
Han ! Han !... Héé ! Attendez-moi les cousins !

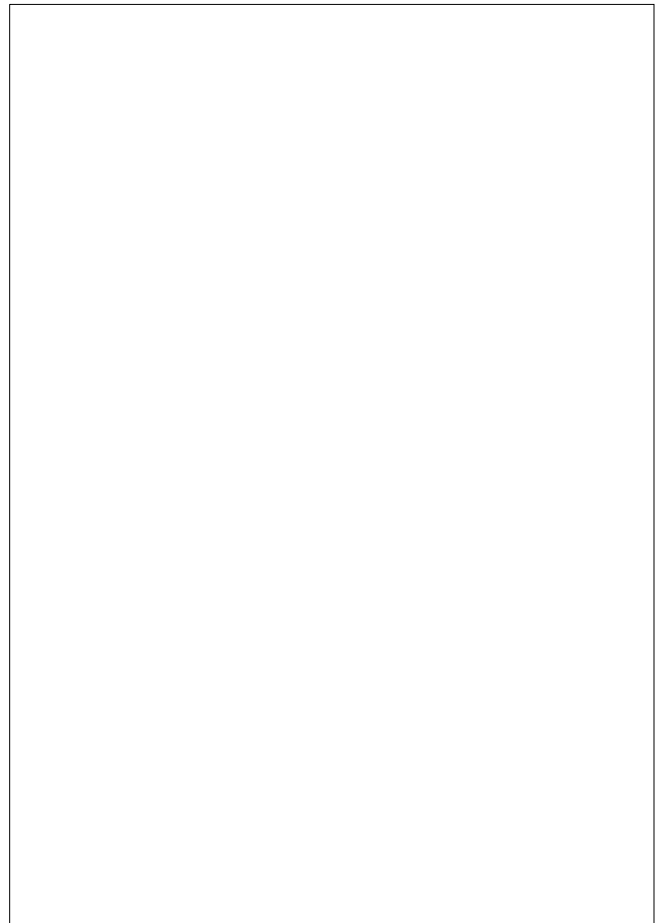



| | | | |
|-------|----------|-------|----------|
| Scene | Duration | Panel | Duration |
| 60 | 07:01 | 4 | 00:21 |

NO PANEL

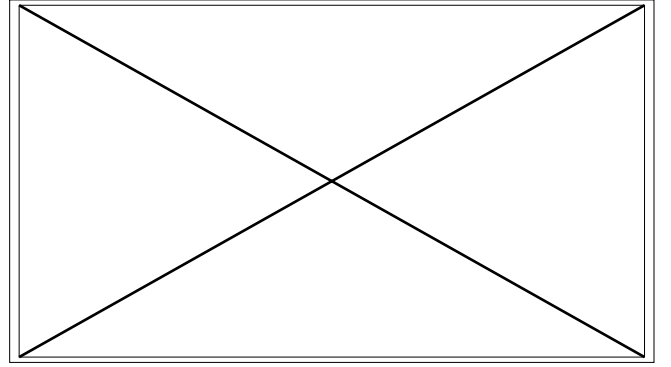
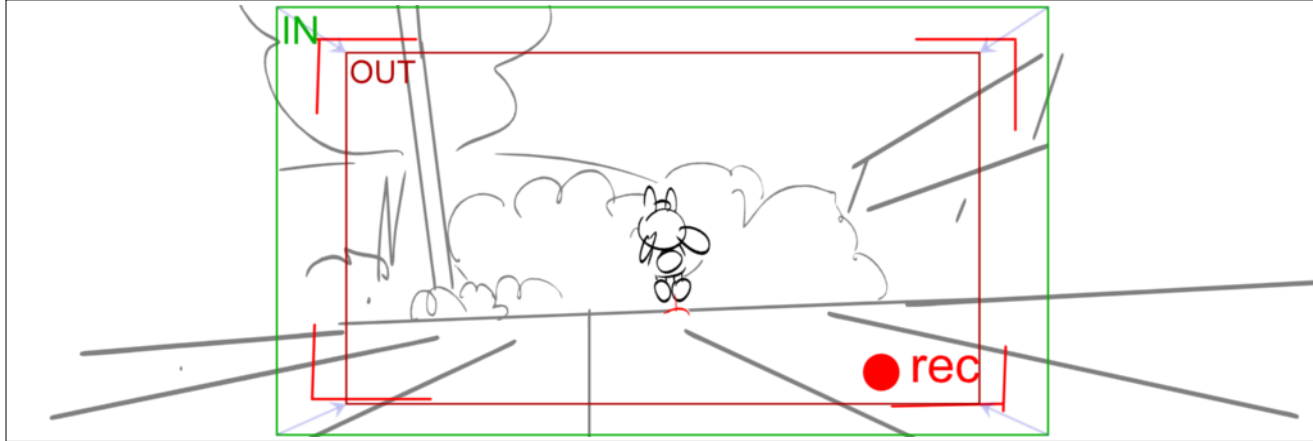

Action Notes

Pot n?arrive pas à sauter par-dessus la haie car il est trop petit.

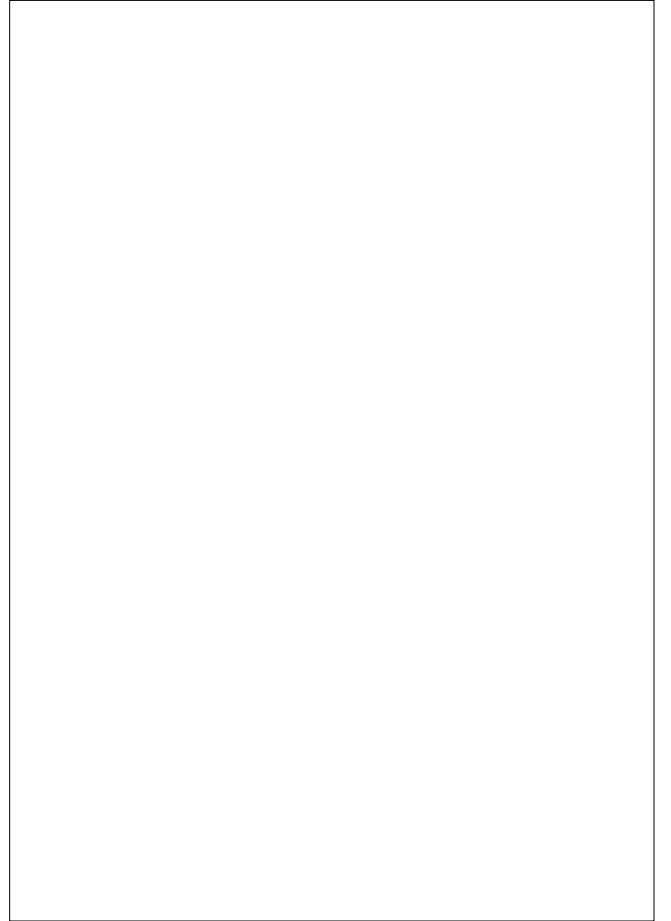



| | | | |
|-------|----------|-------|----------|
| Scene | Duration | Panel | Duration |
| 60 | 07:01 | 5 | 00:21 |

NO PANEL

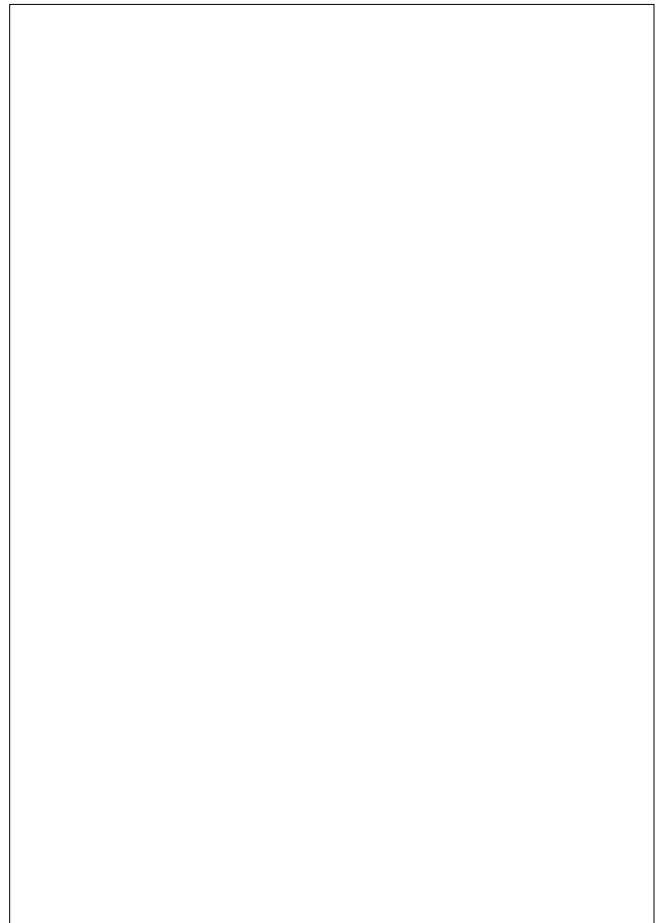
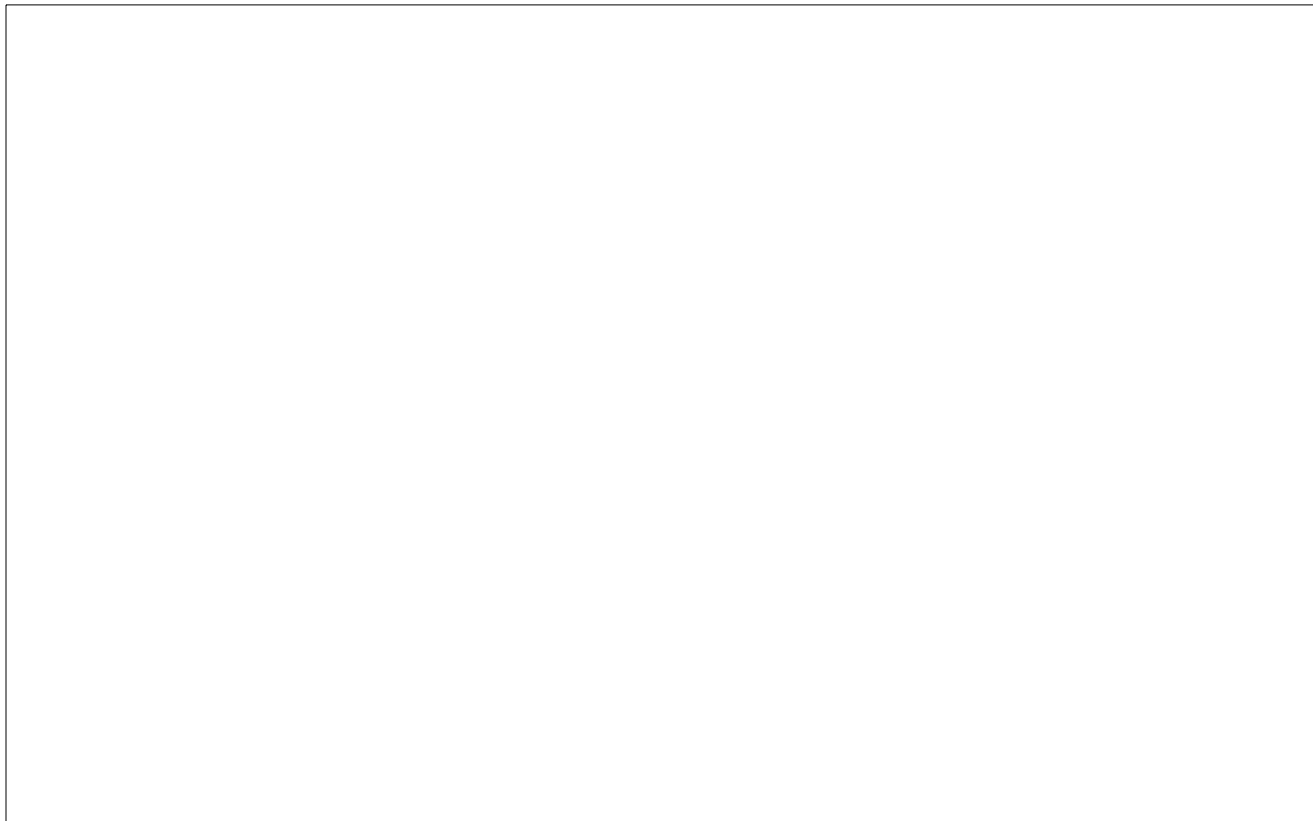
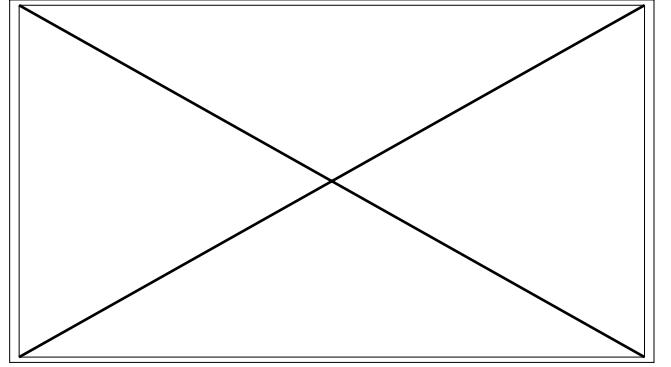
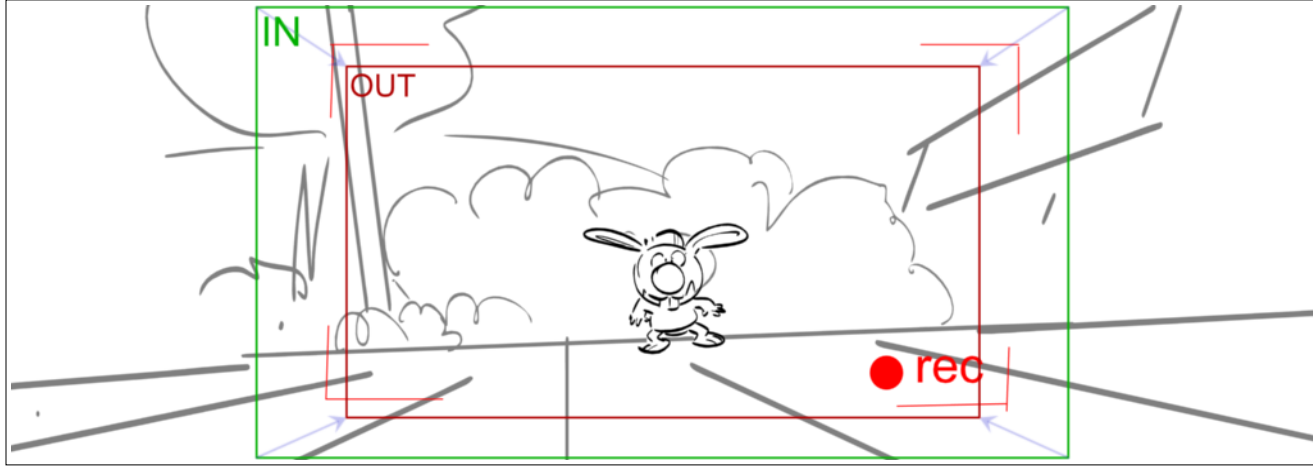



| | | | |
|-------|----------|-------|----------|
| Scene | Duration | Panel | Duration |
| 60 | 07:01 | 6 | 00:21 |

NO PANEL

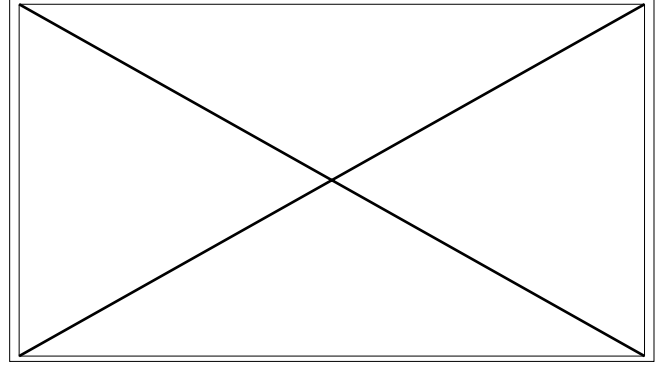
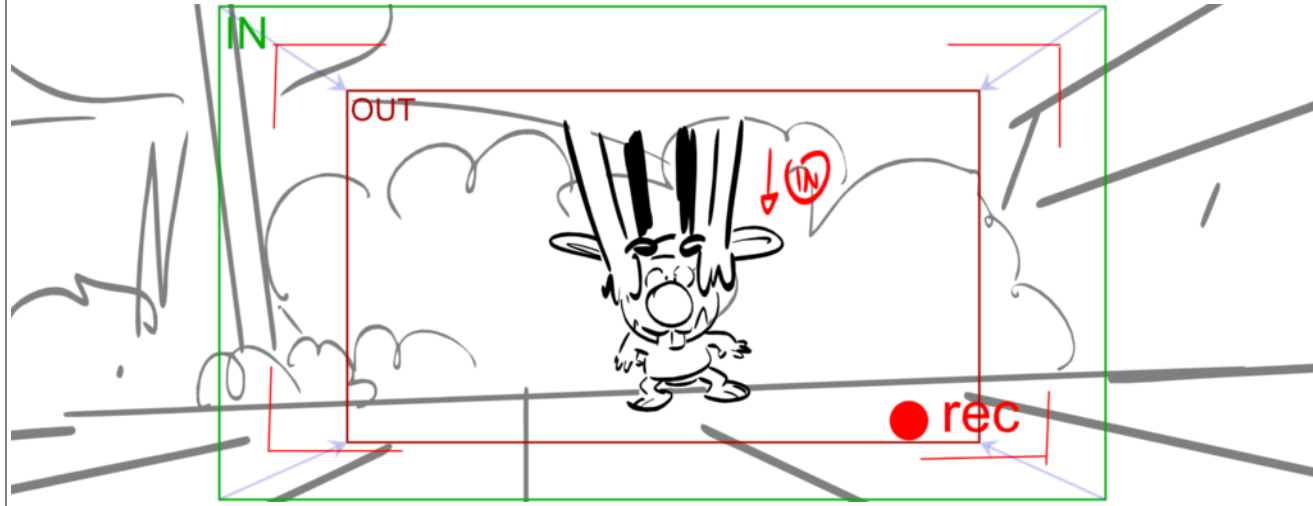

Action Notes

Le petit Lapinet est soulevé du sol pile au moment où Valériano allait l'attraper

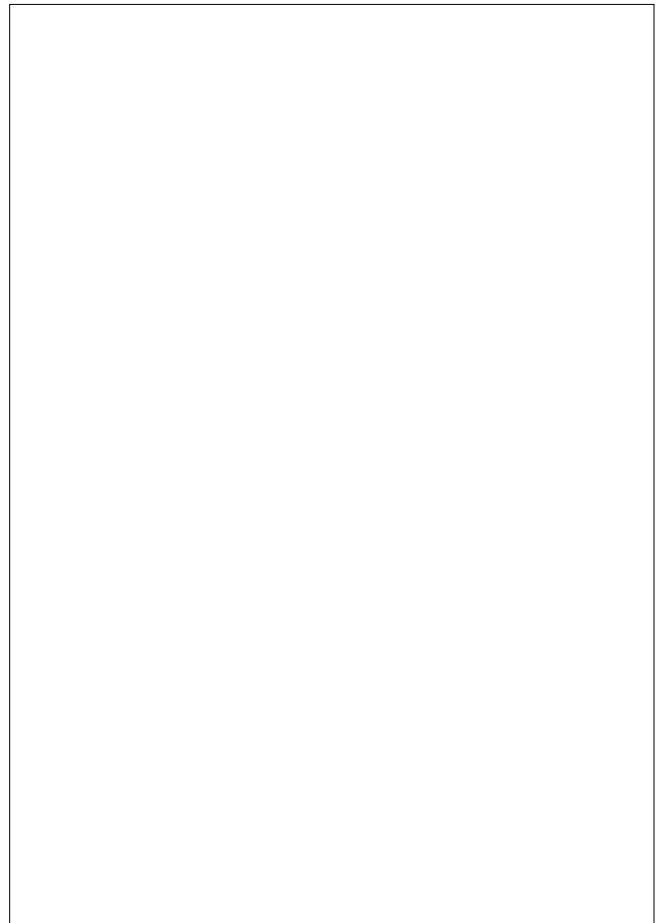

| Scene | Duration | Panel | Duration |
|-------|----------|-------|----------|
| 60 | 07:01 | 7 | 00:21 |

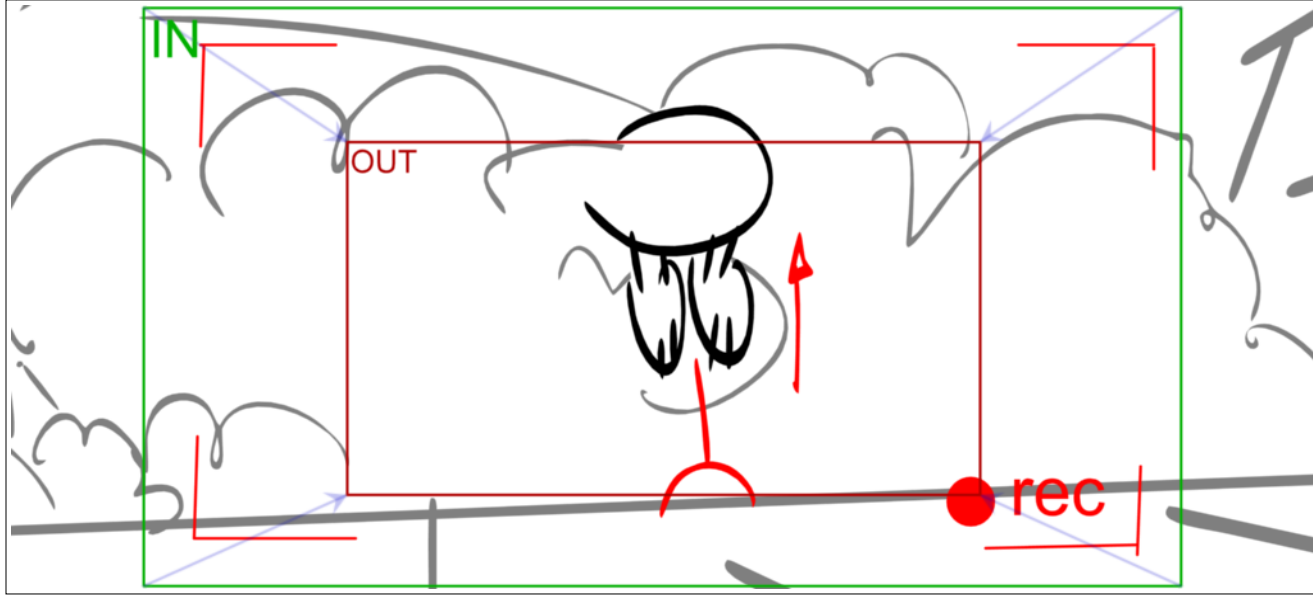

| Scene | Duration | Panel | Duration |
|-------|----------|-------|----------|
| 60 | 07:01 | 8 | 00:18 |

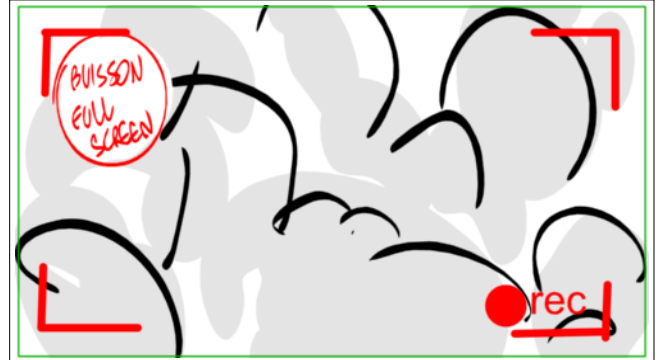

Dialogue

POUFF !

Action Notes

Valériano atterrit la tête la première dans la haie.]



| Scene | Duration | Panel | Duration |
|-------|----------|-------|----------|
| 61 | 01:08 | 1 | 00:05 |

| Scene | Duration | Panel | Duration |
|-------|----------|-------|----------|
| 61 | 01:08 | 2 | 00:08 |

| Scene | Duration | Panel | Duration |
|-------|----------|-------|----------|
| 61 | 01:08 | 3 | 00:07 |

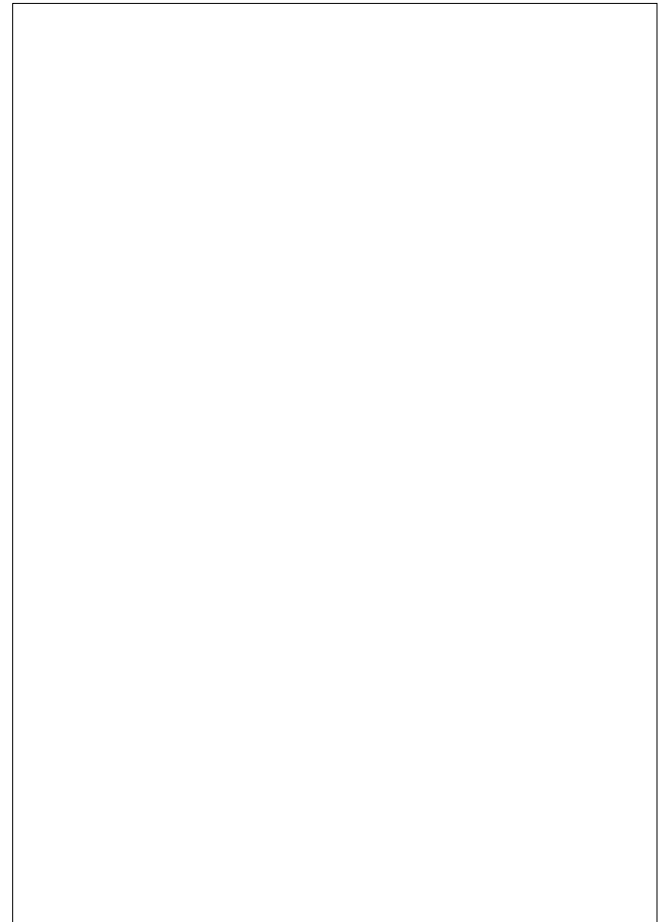
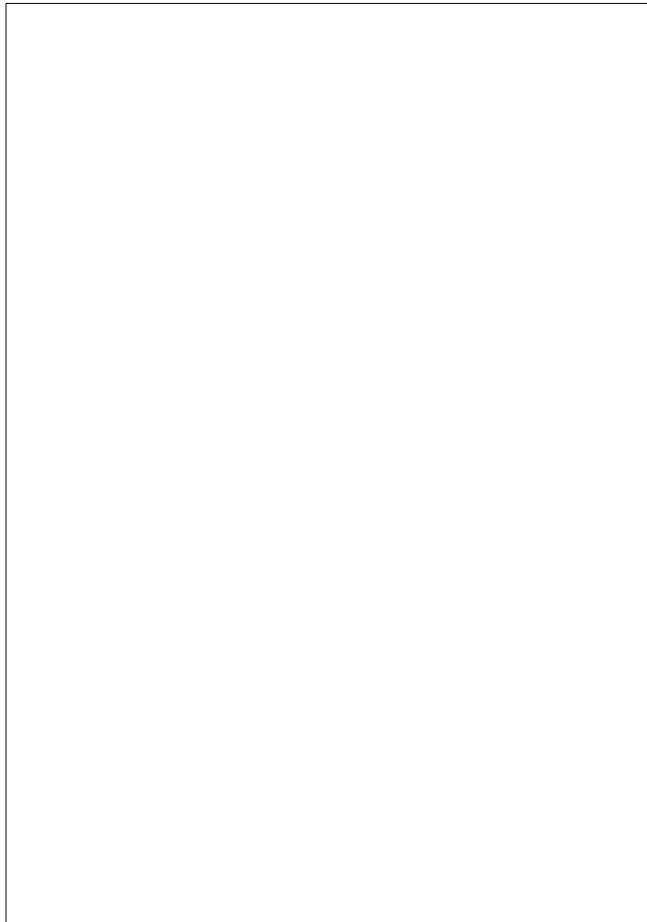



| Scene | Duration | Panel | Duration |
|-------|----------|-------|----------|
| 61 | 01:08 | 4 | 00:08 |



| Scene | Duration | Panel | Duration |
|-------|----------|-------|----------|
| 61 | 01:08 | 5 | 00:05 |



| Scene | Duration | Panel | Duration |
|-------|----------|-------|----------|
| 62 | 07:10 | 1 | 00:04 |

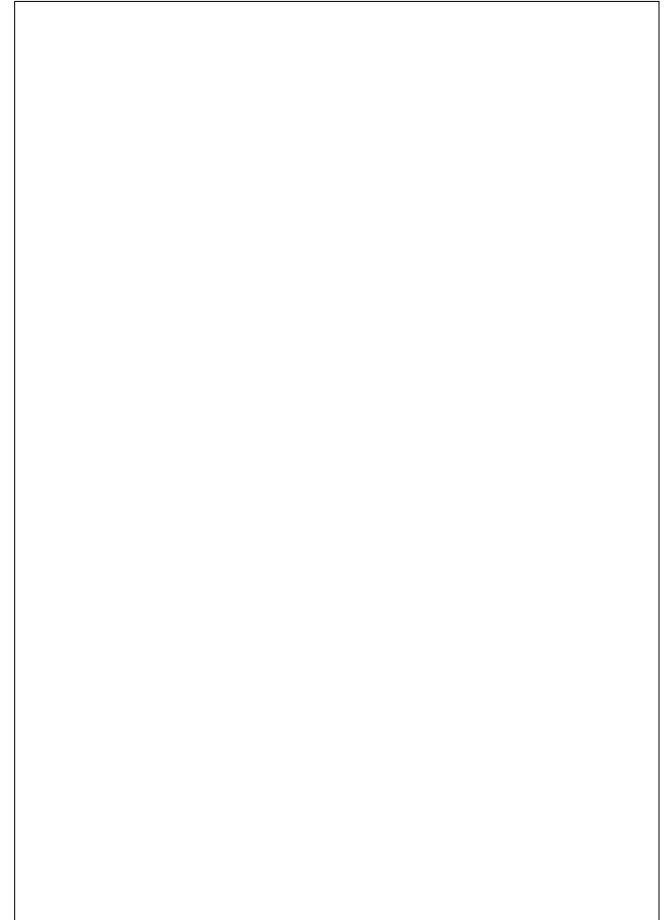
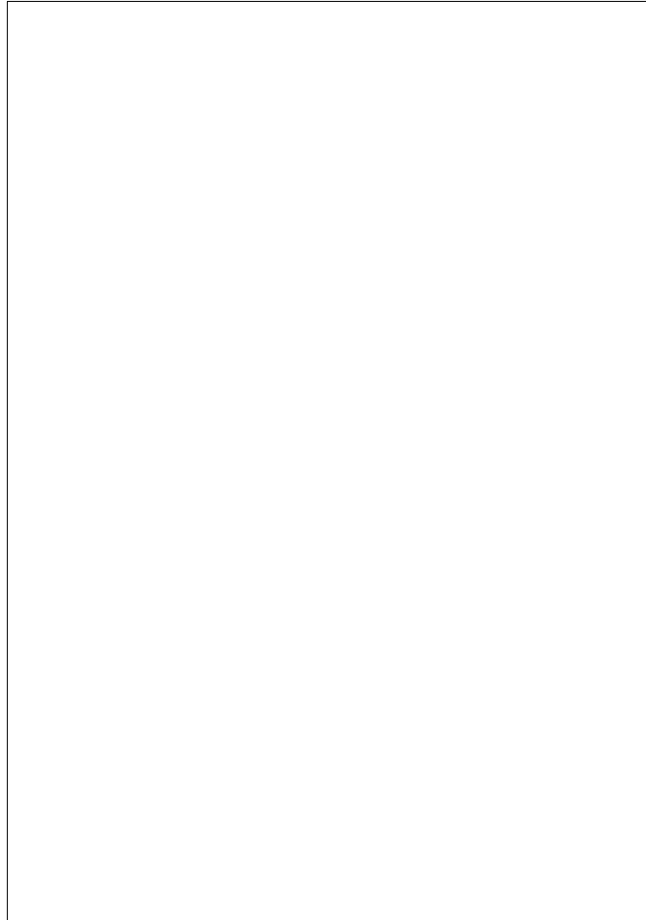
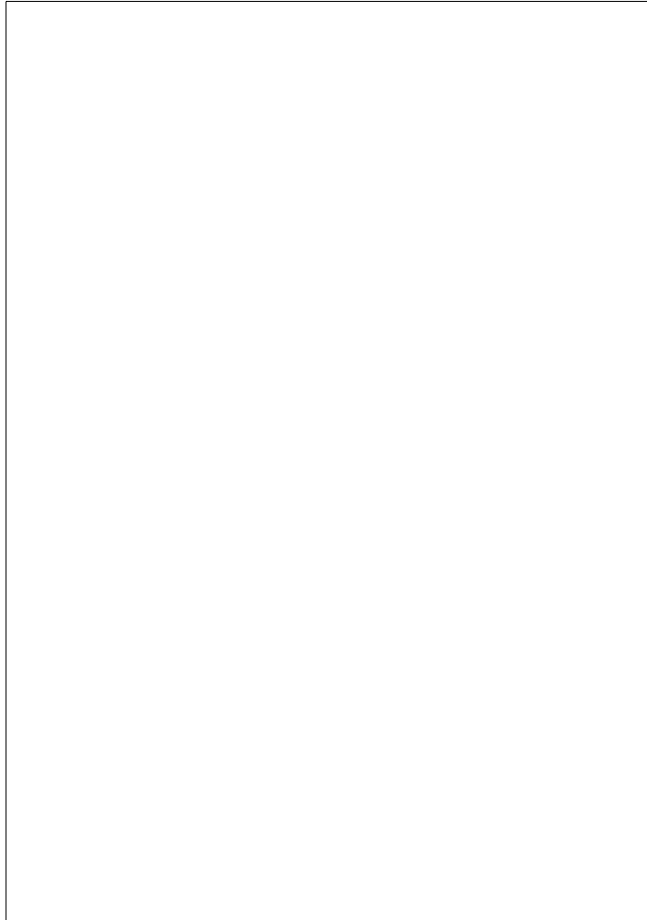

| Scene | Duration | Panel | Duration |
|-------|----------|-------|----------|
| 62 | 07:10 | 2 | 00:10 |



| Scene | Duration | Panel | Duration |
|-------|----------|-------|----------|
| 62 | 07:10 | 3 | 00:10 |



| Scene | Duration | Panel | Duration |
|-------|----------|-------|----------|
| 62 | 07:10 | 4 | 00:08 |

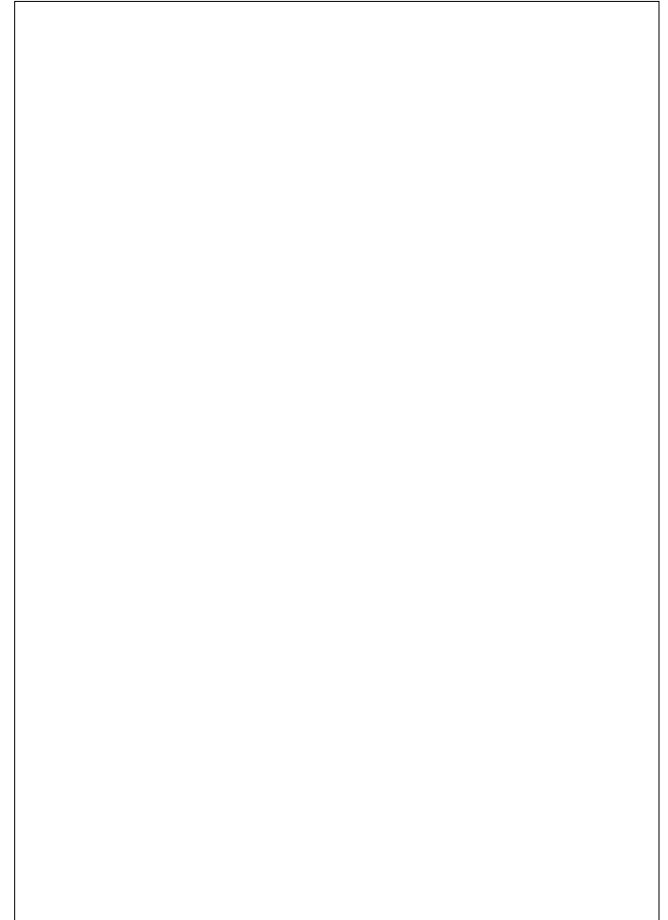
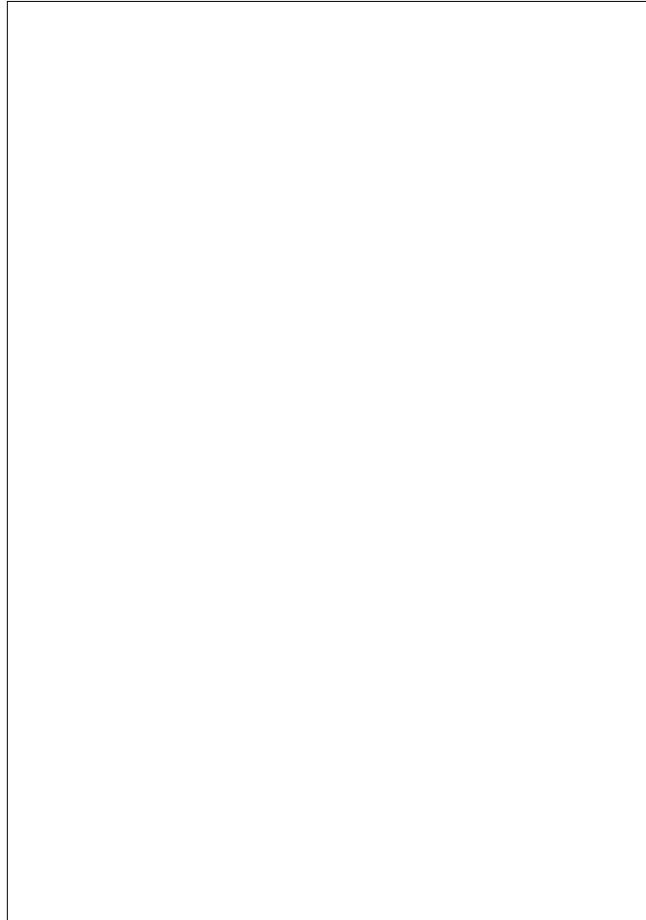
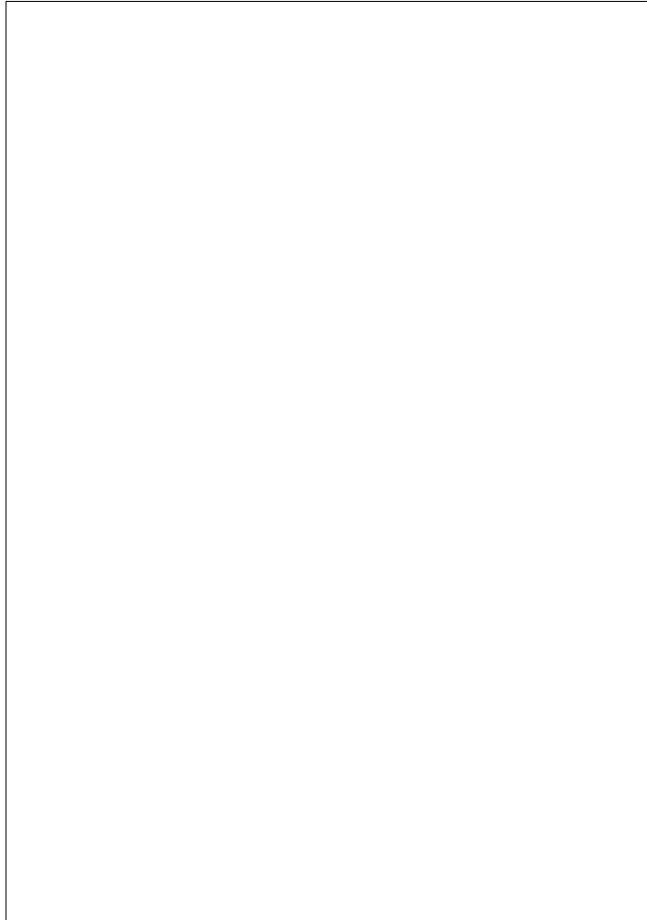
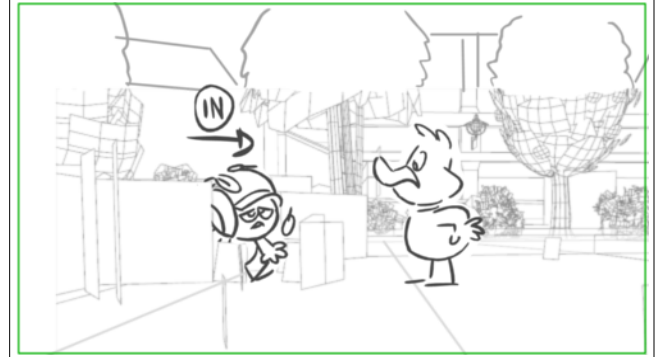

| Scene | Duration | Panel | Duration |
|-------|----------|-------|----------|
| 62 | 07:10 | 5 | 00:09 |

| Scene | Duration | Panel | Duration |
|-------|----------|-------|----------|
| 62 | 07:10 | 6 | 01:01 |

NO PANEL

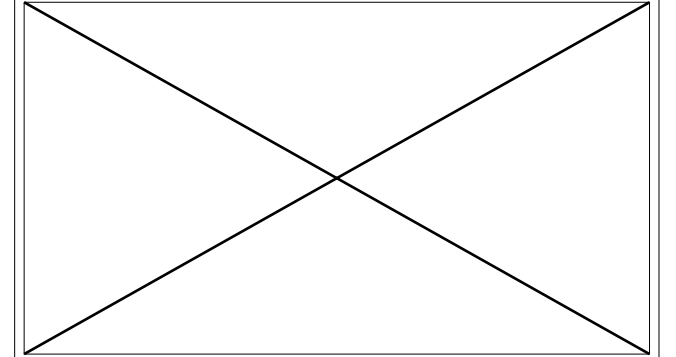
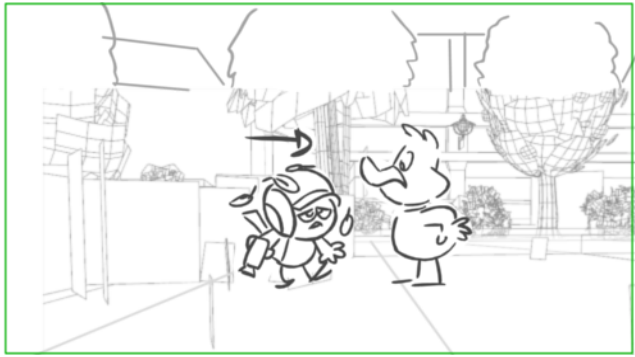

Action Notes
 Valeriano sort des buissons groggy

Dialogue
 PICK UP VALERIANO
 Si jamais je les attrappe ceux là!!

| Scene | Duration | Panel | Duration |
|-------|----------|-------|----------|
| 62 | 07:10 | 7 | 01:01 |

| Scene | Duration | Panel | Duration |
|-------|----------|-------|----------|
| 62 | 07:10 | 8 | 01:10 |

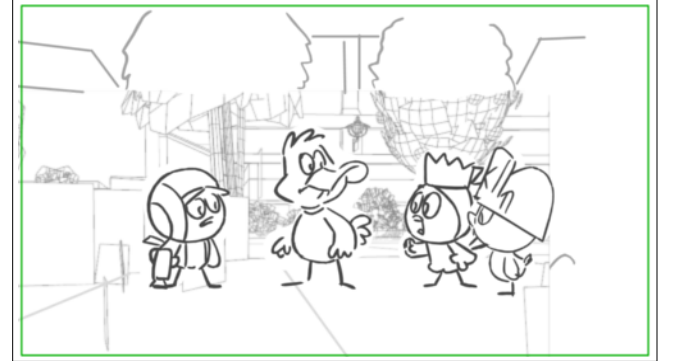

Dialogue

54. PRISCILLA
Allez les garçons!

| Scene | Duration | Panel | Duration |
|-------|----------|-------|----------|
| 62 | 07:10 | 9 | 01:07 |



Dialogue

54. PRISCILLA

Laissez les! On a un film a finir

| Scene | Duration | Panel | Duration |
|-------|----------|-------|----------|
| 62 | 07:10 | 10 | 01:00 |

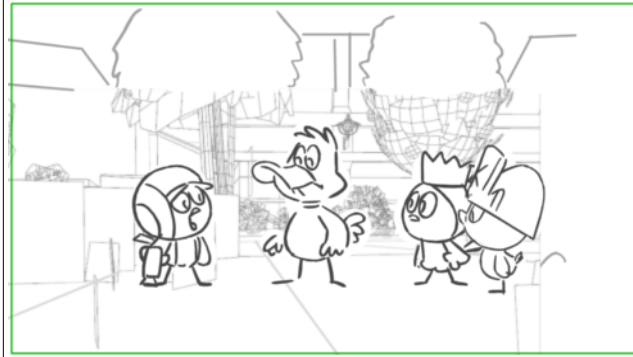

Dialogue

55. VALERIANO

On va la refaire, les amis...

| Scene | Duration | Panel | Duration |
|-------|----------|-------|----------|
| 63 | 03:04 | 1 | 00:12 |



Dialogue

55. VALERIANO

BOn d'accord!

| Scene | Duration | Panel | Duration |
|-------|----------|-------|----------|
| 63 | 03:04 | 2 | 01:17 |



Dialogue
 55. VALERIANO
 On va la refaire, les amis...

| Scene | Duration | Panel | Duration |
|-------|----------|-------|----------|
| 63 | 03:04 | 3 | 01:00 |



Dialogue
 55. VALERIANO
 Oh nonn !

| Scene | Duration | Panel | Duration |
|-------|----------|-------|----------|
| 64 | 03:01 | 1 | 00:08 |

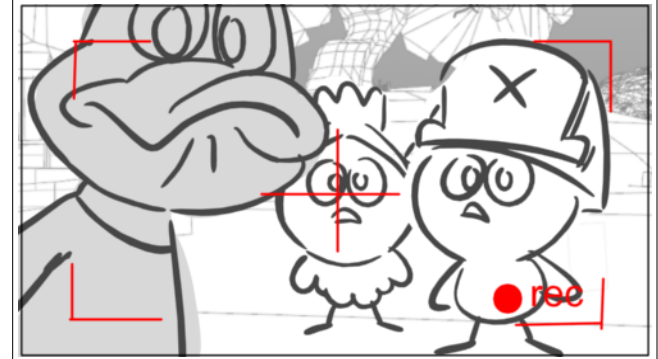

Dialogue
 55. VALERIANO
 Y?a plus de batterie !

| Scene | Duration | Panel | Duration |
|-------|----------|-------|----------|
| 64 | 03:01 | 2 | 00:08 |

| Scene | Duration | Panel | Duration |
|-------|----------|-------|----------|
| 64 | 03:01 | 3 | 00:08 |

| Scene | Duration | Panel | Duration |
|-------|----------|-------|----------|
| 64 | 03:01 | 4 | 00:09 |

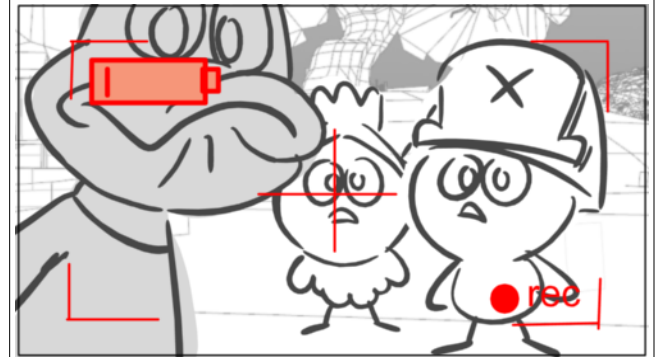
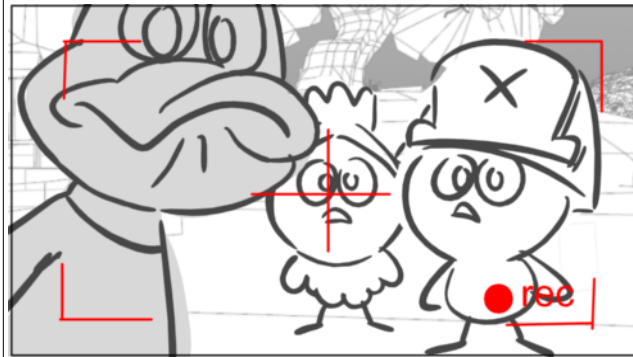
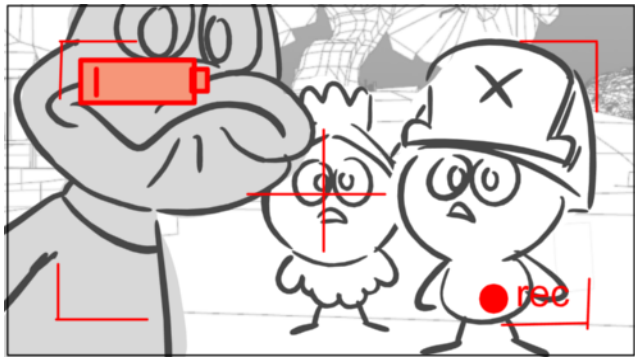

Dialogue
 55. VALERIANO
 Y?a plus de batterie !

Dialogue
 55. VALERIANO
 Y?a plus de batterie !

Dialogue
 55. VALERIANO
 Y?a plus de batterie !

Action Notes
 Le voyant indique que la batterie est vide

| Scene | Duration | Panel | Duration |
|-------|----------|-------|----------|
| 64 | 03:01 | 5 | 00:08 |

| Scene | Duration | Panel | Duration |
|-------|----------|-------|----------|
| 64 | 03:01 | 6 | 00:09 |

| Scene | Duration | Panel | Duration |
|-------|----------|-------|----------|
| 64 | 03:01 | 7 | 00:09 |

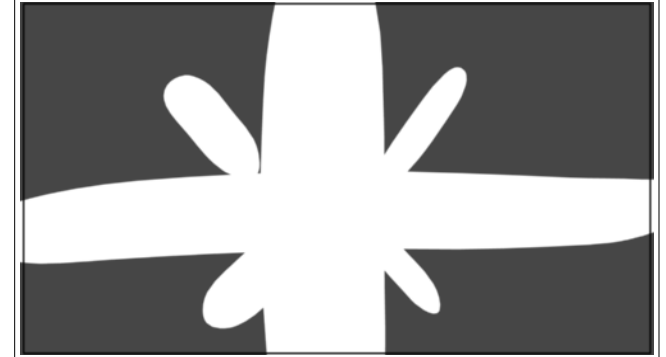
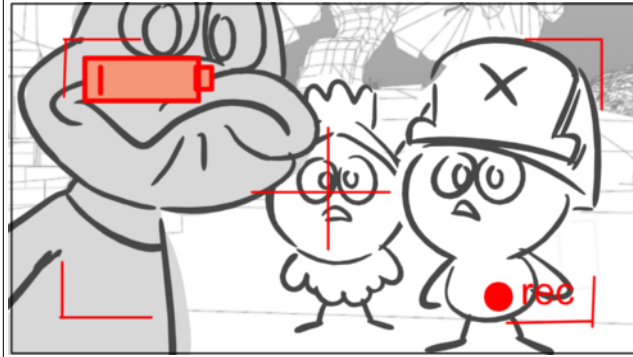
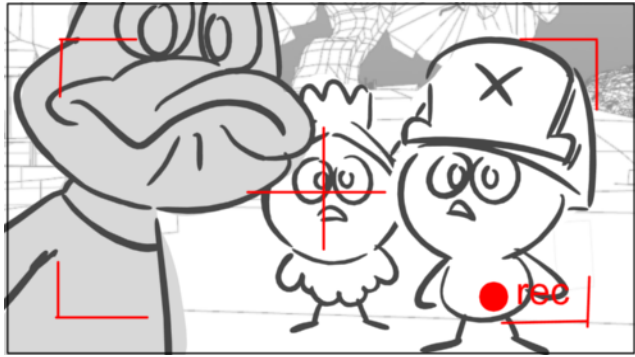

Dialogue
 55. VALERIANO
 Y?a plus de batterie !

Dialogue
 55. VALERIANO
 Y?a plus de batterie !

Action Notes
 La CAM s' teint

| Scene | Duration | Panel | Duration |
|-------|----------|-------|----------|
| 64 | 03:01 | 8 | 00:17 |



| Scene | Duration | Panel | Duration |
|-------|----------|-------|----------|
| 65 | 09:08 | 1 | 01:00 |

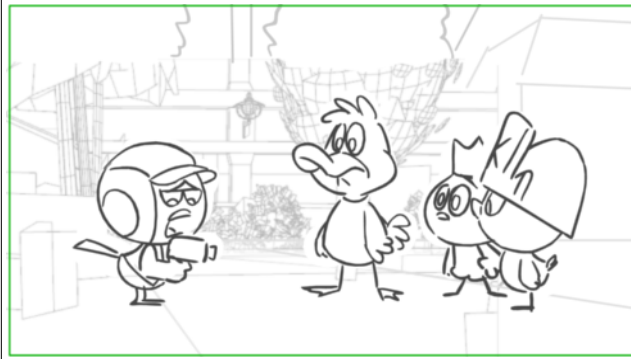

Dialogue

55. VALERIANO

J'ai même pas tourné une seule bonne scène !

| Scene | Duration | Panel | Duration |
|-------|----------|-------|----------|
| 65 | 09:08 | 2 | 01:20 |

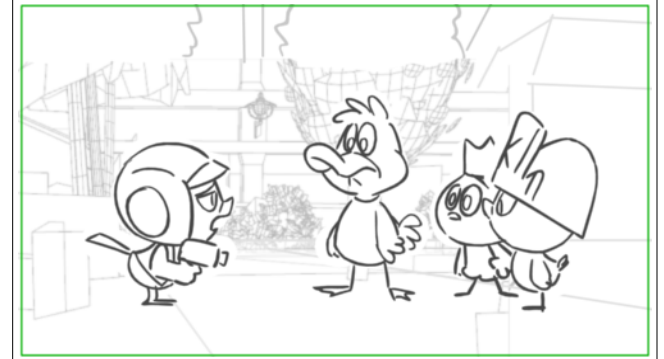

Dialogue

55. VALERIANO

J'ai même pas tourné une seule bonne scène !

| Scene | Duration | Panel | Duration |
|-------|----------|-------|----------|
| 65 | 09:08 | 3 | 02:12 |

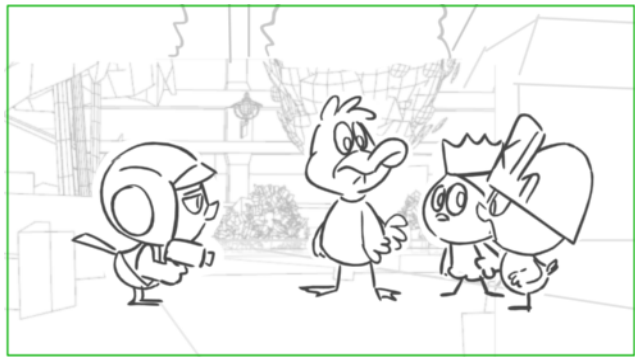

Dialogue

56. CALIMERO
Allons recharger la batterie chez moi !

| Scene | Duration | Panel | Duration |
|-------|----------|-------|----------|
| 65 | 09:08 | 4 | 00:24 |

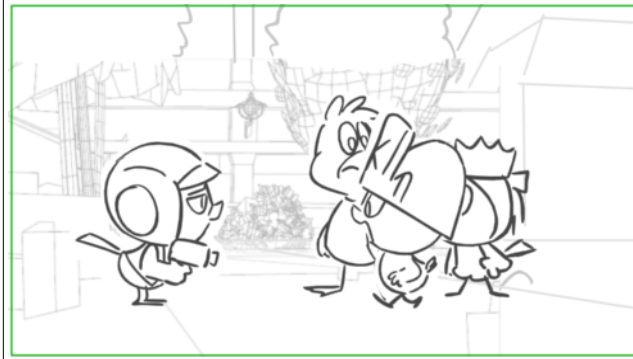

Dialogue

56. CALIMERO
On regardera ce qu'on a filmé.

| Scene | Duration | Panel | Duration |
|-------|----------|-------|----------|
| 65 | 09:08 | 5 | 01:01 |

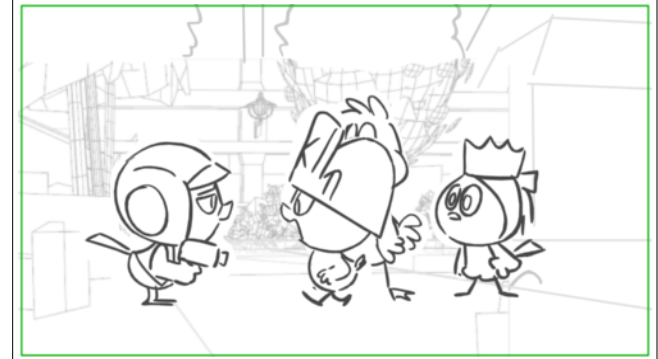

Dialogue

56. CALIMERO
On regardera ce qu'on a filmé.

| Scene | Duration | Panel | Duration |
|-------|----------|-------|----------|
| 65 | 09:08 | 6 | 02:01 |

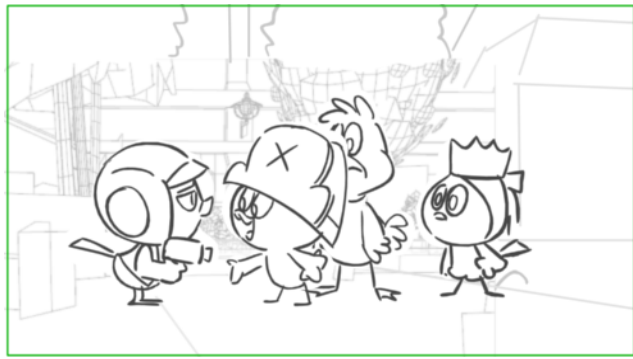

Dialogue

56. CALIMERO

Peut-être que tout n'est pas raté ??

| Scene | Duration | Panel | Duration |
|-------|----------|-------|----------|
| 66 | 02:05 | 1 | 02:05 |

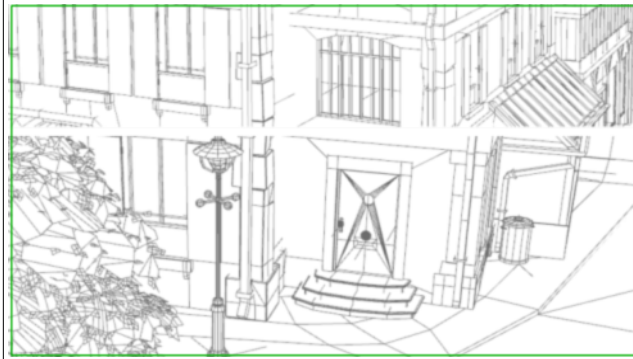

Dialogue

57. VALERIANO (dépité)

Peuh ! Tout le film est raté à cause des Lapinet?

Action Notes

EXT devant chez CAL jjour

| Scene | Duration | Panel | Duration |
|-------|----------|-------|----------|
| 67 | 04:17 | 1 | 00:19 |



Dialogue

57. VALERIANO (dépité)

Tout le film est raté à cause des Lapinet?

Action Notes

7. CUISINE CALIMERO / INT. JOUR

| Scene | Duration | Panel | Duration |
|-------|----------|-------|----------|
| 67 | 04:17 | 2 | 00:18 |

| Scene | Duration | Panel | Duration |
|-------|----------|-------|----------|
| 67 | 04:17 | 3 | 00:17 |

| Scene | Duration | Panel | Duration |
|-------|----------|-------|----------|
| 67 | 04:17 | 4 | 00:17 |

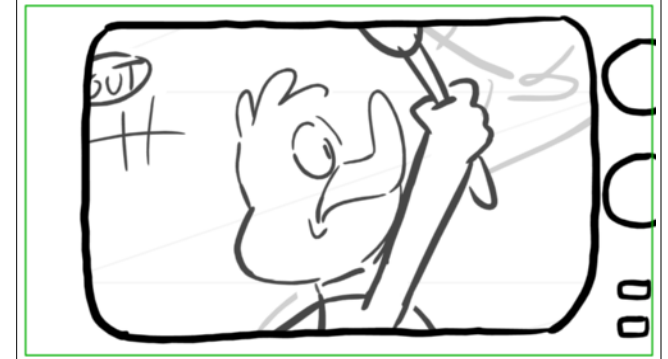
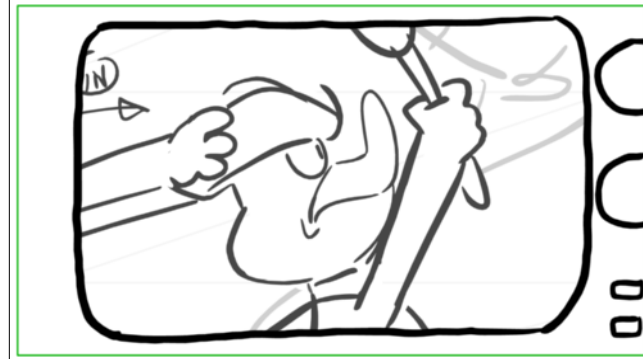
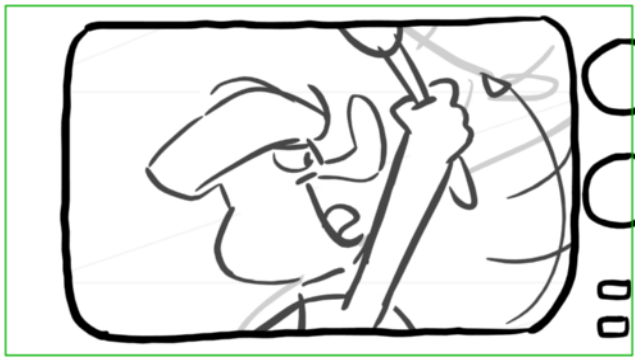

Dialogue

57. VALERIANO (dépité)
C'est fini pour le concours?

| Scene | Duration | Panel | Duration |
|-------|----------|-------|----------|
| 67 | 04:17 | 5 | 00:17 |



| Scene | Duration | Panel | Duration |
|-------|----------|-------|----------|
| 67 | 04:17 | 6 | 01:04 |

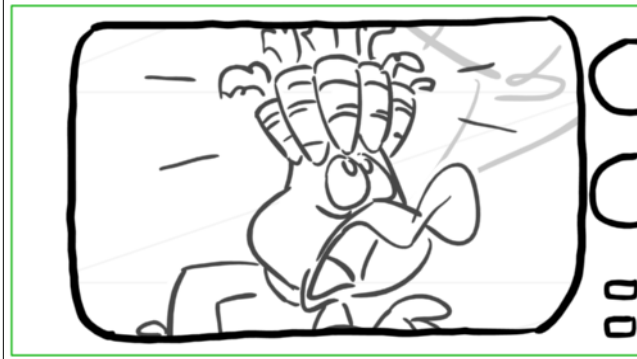

| Scene | Duration | Panel | Duration |
|-------|----------|-------|----------|
| 68 | 12:15 | 1 | 01:06 |



Dialogue

58. CALIMERO (outré)
C'est vraiment trop injuste !

| Scene | Duration | Panel | Duration |
|-------|----------|-------|----------|
| 68 | 12:15 | 2 | 01:04 |



Dialogue

58. CALIMERO (outré)
C'est vraiment trop injuste !

| Scene | Duration | Panel | Duration |
|-------|----------|-------|----------|
| 68 | 12:15 | 3 | 02:17 |



Dialogue

59. PIERROT
Peuh, ces nazbroks de Lapinet ! Ils nous fatiguent avec leurs carottes !

| Scene | Duration | Panel | Duration |
|-------|----------|-------|----------|
| 68 | 12:15 | 4 | 02:09 |



Dialogue

59. PIERROT
Peuh, ces nazbroks de Lapinet ! Ils nous fatiguent avec leurs carottes !

| Scene | Duration | Panel | Duration |
|-------|----------|-------|----------|
| 68 | 12:15 | 5 | 00:14 |

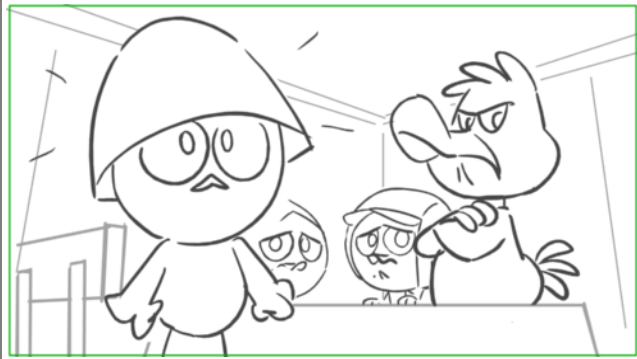

| Scene | Duration | Panel | Duration |
|-------|----------|-------|----------|
| 68 | 12:15 | 6 | 01:24 |

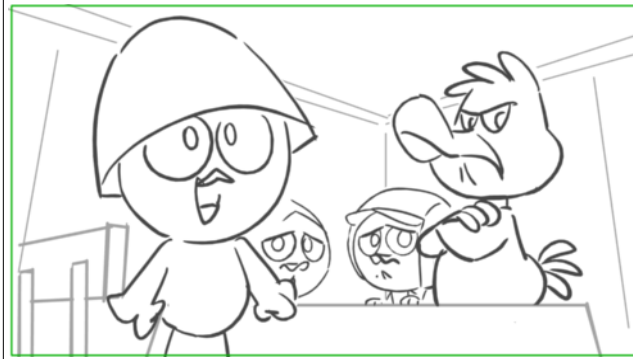

Dialogue

60. CALIMERO (pensif, à lui-même)
Les carottes...

| Scene | Duration | Panel | Duration |
|-------|----------|-------|----------|
| 68 | 12:15 | 7 | 02:16 |

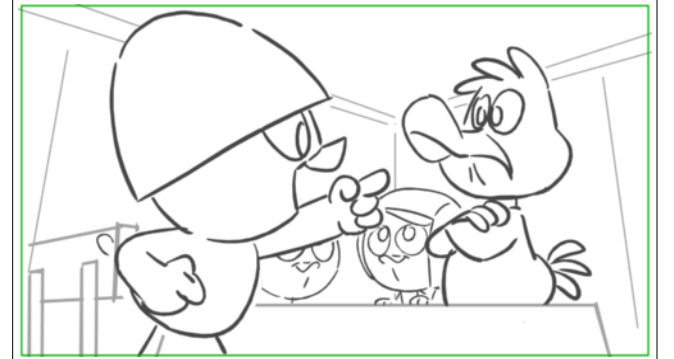

Dialogue

60. CALIMERO (pensif, à lui-même)
C'est ça ! Bravo Pierrot !

| Scene | Duration | Panel | Duration |
|-------|----------|-------|----------|
| 69 | 08:12 | 1 | 01:08 |

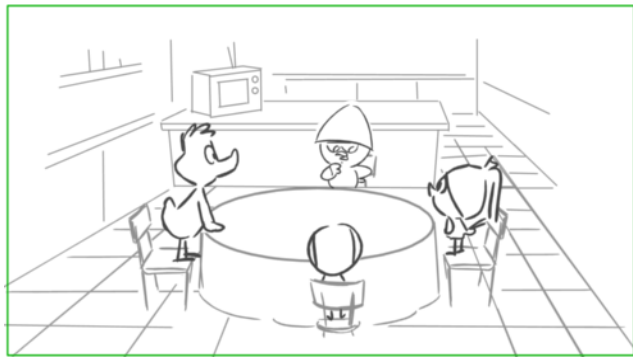

Dialogue

60. CALIMERO (pensif, à lui-même)
Je crois que j'ai une idée pour sauver le film !

| Scene | Duration | Panel | Duration |
|-------|----------|-------|----------|
| 69 | 08:12 | 2 | 01:22 |

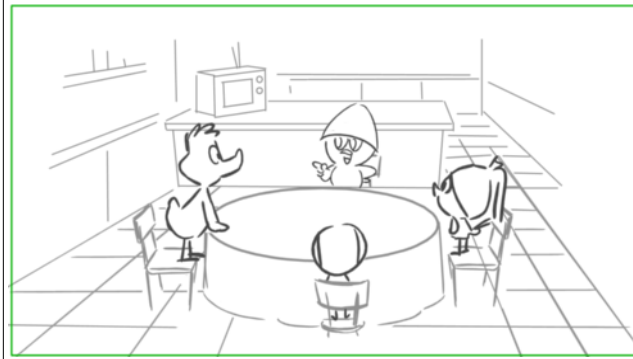

Dialogue

60. CALIMERO (pensif, à lui-même)
Je crois que j'ai une idée pour sauver le film !

| Scene | Duration | Panel | Duration |
|-------|----------|-------|----------|
| 69 | 08:12 | 3 | 02:04 |



Dialogue

61. CALIMERO (explique son plan)
Comme les Lapinet sont partout,

| Scene | Duration | Panel | Duration |
|-------|----------|-------|----------|
| 69 | 08:12 | 4 | 03:03 |

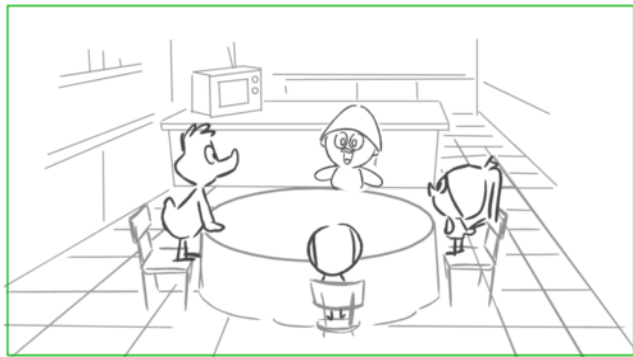

Dialogue

61. CALIMERO (explique son plan)
alors? on va faire un film sur les
Lapinet !

| Scene | Duration | Panel | Duration |
|-------|----------|-------|----------|
| 70 | 01:11 | 1 | 00:12 |



Dialogue

62. VALERIANO / PRISCILLA / PIERROT
(surpris)
Hein ?!!

| Scene | Duration | Panel | Duration |
|-------|----------|-------|----------|
| 70 | 01:11 | 2 | 00:24 |



Dialogue

62. VALERIANO / PRISCILLA / PIERROT
(surpris)
Hein ?!!

| Scene | Duration | Panel | Duration |
|-------|----------|-------|----------|
| 71 | 07:24 | 1 | 03:23 |



Dialogue

63. CALIMERO (malicieux)
 On utilisera des machines de Do Vinci
 pour tourner la suite du film!

| Scene | Duration | Panel | Duration |
|-------|----------|-------|----------|
| 71 | 07:24 | 2 | 00:19 |

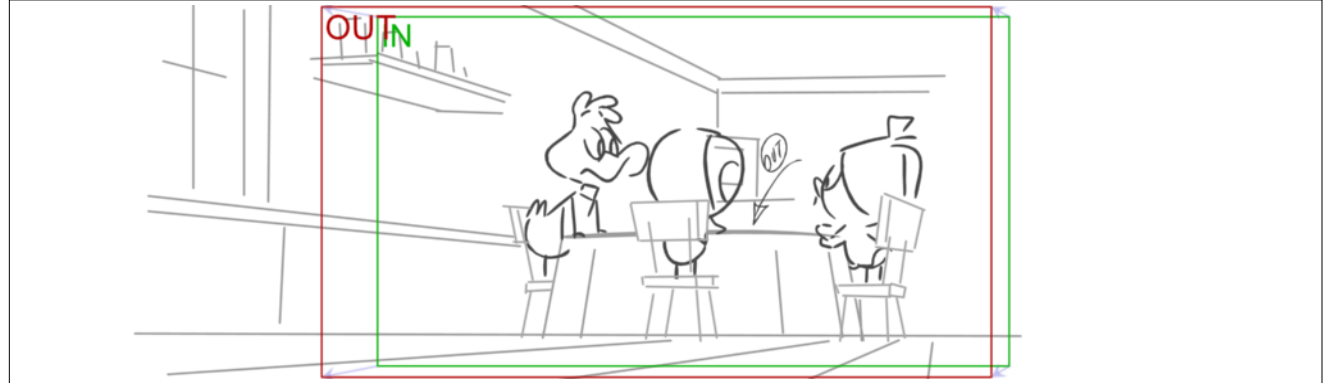

| Scene | Duration | Panel | Duration |
|-------|----------|-------|----------|
| 71 | 07:24 | 3 | 02:07 |

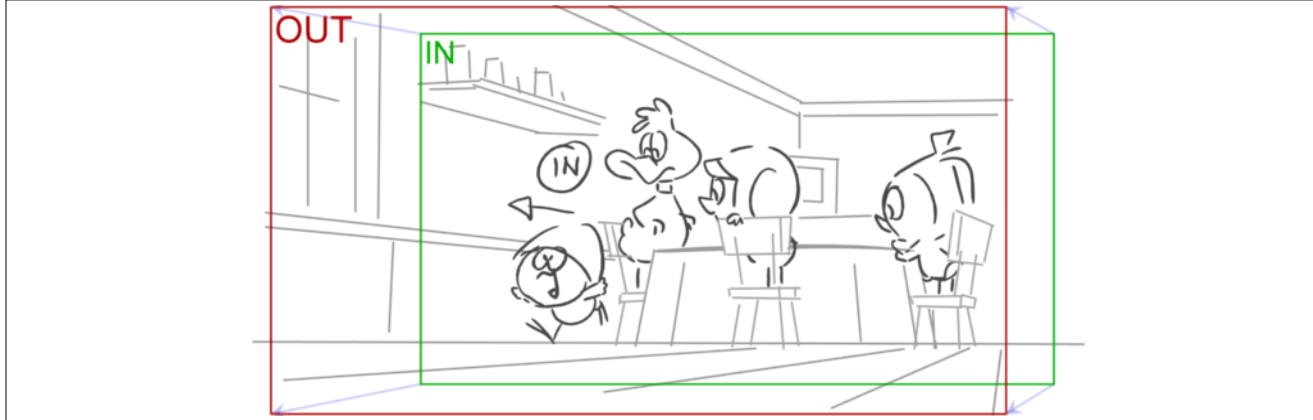

Dialogue

63. CALIMERO (malicieux)
 Il ne nous manque plus que les derniers accessoires?

| Scene | Duration | Panel | Duration |
|-------|----------|-------|----------|
| 71 | 07:24 | 4 | 00:18 |



Dialogue

PICK UP CALIMERO (malicieux)
 Vite !

| Scene | Duration | Panel | Duration |
|-------|----------|-------|----------|
| 71 | 07:24 | 5 | 00:07 |

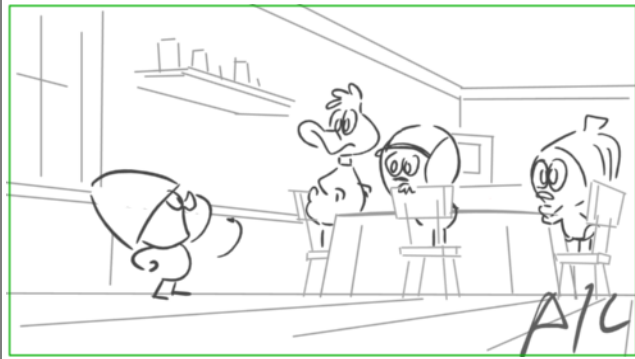

| Scene | Duration | Panel | Duration |
|-------|----------|-------|----------|
| 72 | 01:19 | 1 | 00:19 |

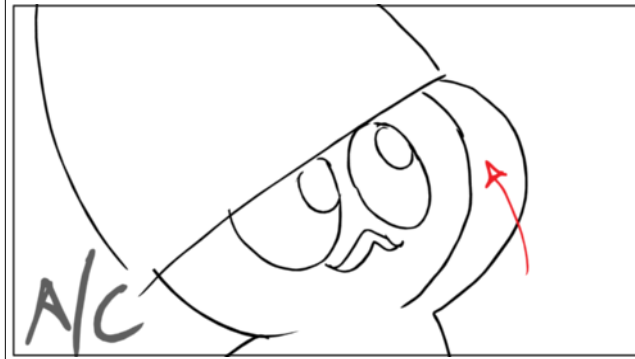

| Scene | Duration | Panel | Duration |
|-------|----------|-------|----------|
| 72 | 01:19 | 2 | 01:00 |

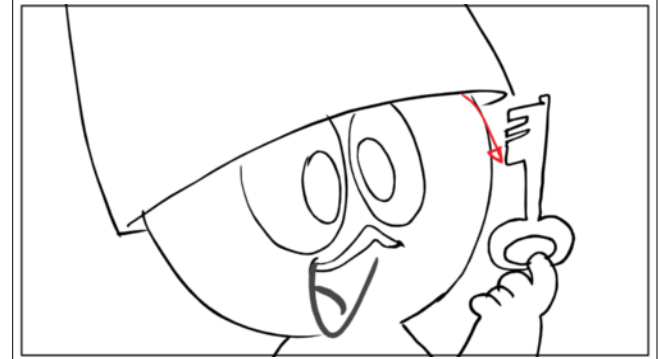

Dialogue

63. CALIMERO (malicieux)
Tous au moulin !

| Scene | Duration | Panel | Duration |
|-------|----------|-------|----------|
| 73 | 01:10 | 1 | 00:04 |

| Scene | Duration | Panel | Duration |
|-------|----------|-------|----------|
| 73 | 01:10 | 2 | 00:09 |

| Scene | Duration | Panel | Duration |
|-------|----------|-------|----------|
| 73 | 01:10 | 3 | 00:06 |

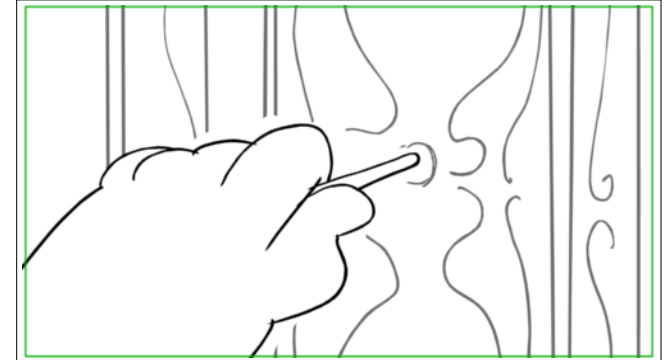
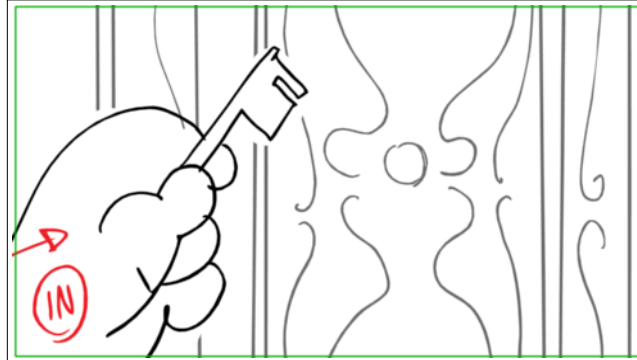
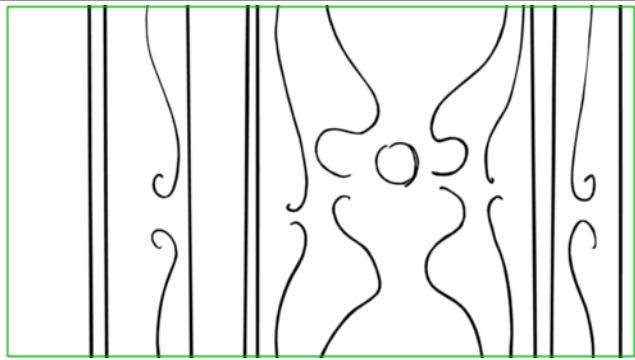

Action Notes
close up on fire place

Action Notes
cali in

Action Notes
put key in

| Scene | Duration | Panel | Duration |
|-------|----------|-------|----------|
| 73 | 01:10 | 4 | 00:16 |

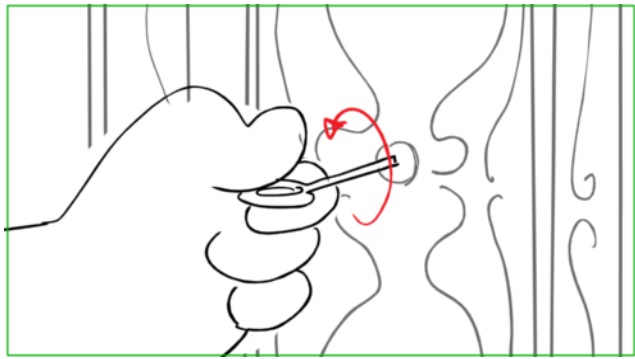

Action Notes
turn

| Scene | Duration | Panel | Duration |
|-------|----------|-------|----------|
| 74 | 01:06 | 1 | 00:06 |

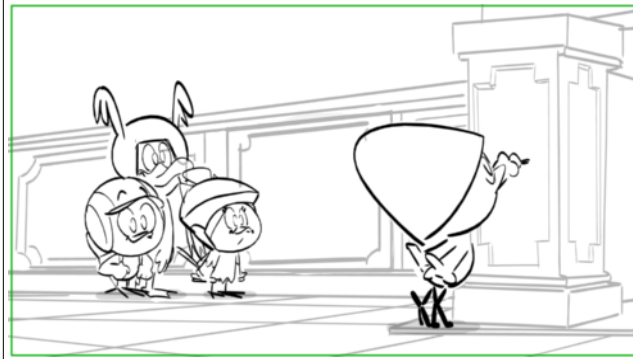

| Scene | Duration | Panel | Duration |
|-------|----------|-------|----------|
| 74 | 01:06 | 2 | 01:00 |

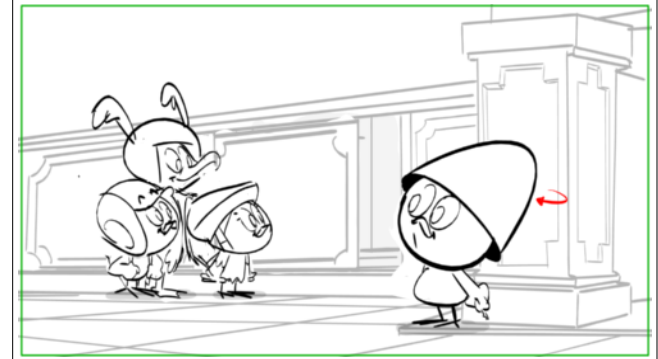

Action Notes
the secret door opens



| Scene | Duration | Panel | Duration |
|-------|----------|-------|----------|
| 75 | 05:23 | 1 | 00:11 |



| Scene | Duration | Panel | Duration |
|-------|----------|-------|----------|
| 75 | 05:23 | 2 | 00:14 |

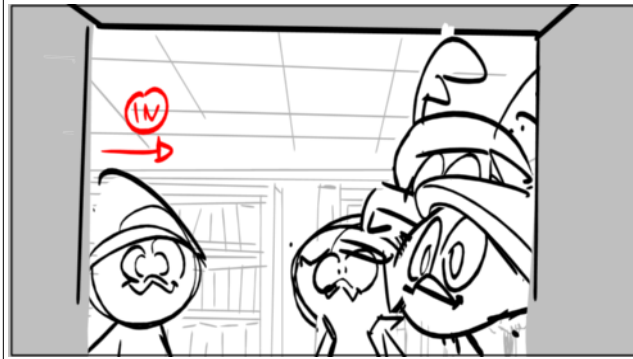

Action Notes
Priscilla jumps in/out

| Scene | Duration | Panel | Duration |
|-------|----------|-------|----------|
| 75 | 05:23 | 3 | 00:07 |

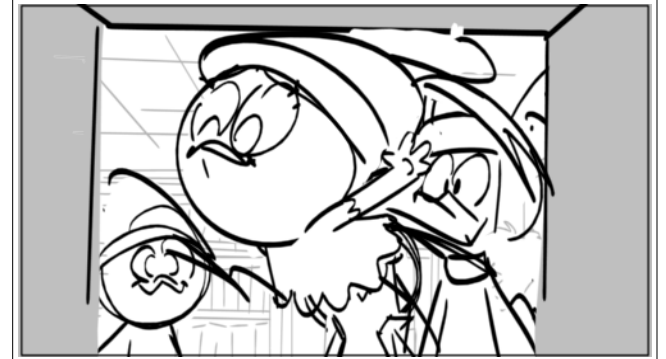

| Scene | Duration | Panel | Duration |
|-------|----------|-------|----------|
| 75 | 05:23 | 4 | 00:04 |

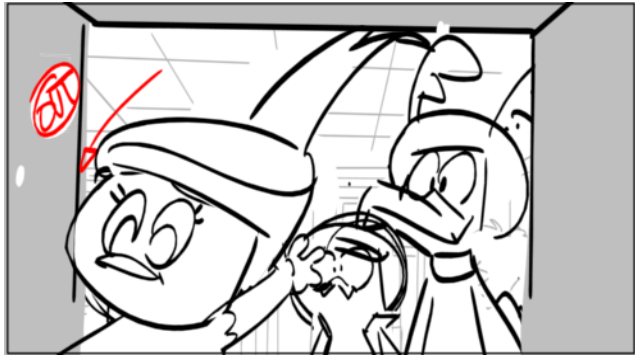

| Scene | Duration | Panel | Duration |
|-------|----------|-------|----------|
| 75 | 05:23 | 5 | 00:08 |

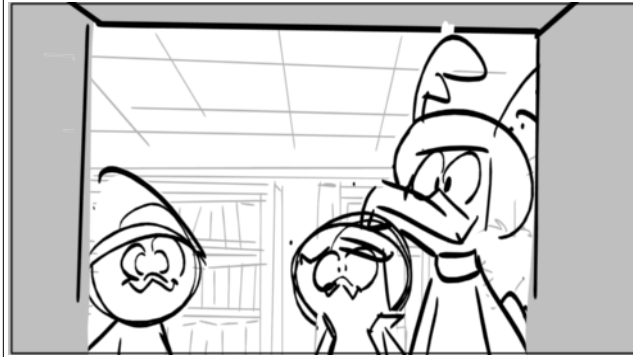

| Scene | Duration | Panel | Duration |
|-------|----------|-------|----------|
| 75 | 05:23 | 6 | 00:08 |



Action Notes

Valeriano jumps in/out

| Scene | Duration | Panel | Duration |
|-------|----------|-------|----------|
| 75 | 05:23 | 7 | 00:06 |

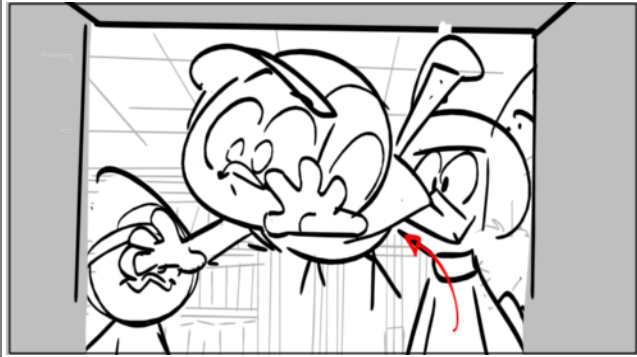

| Scene | Duration | Panel | Duration |
|-------|----------|-------|----------|
| 75 | 05:23 | 8 | 00:06 |



| Scene | Duration | Panel | Duration |
|-------|----------|-------|----------|
| 75 | 05:23 | 9 | 00:08 |





| Scene | Duration | Panel | Duration |
|-------|----------|-------|----------|
| 75 | 05:23 | 10 | 00:08 |

| Scene | Duration | Panel | Duration |
|-------|----------|-------|----------|
| 75 | 05:23 | 11 | 00:05 |

| Scene | Duration | Panel | Duration |
|-------|----------|-------|----------|
| 75 | 05:23 | 12 | 00:09 |

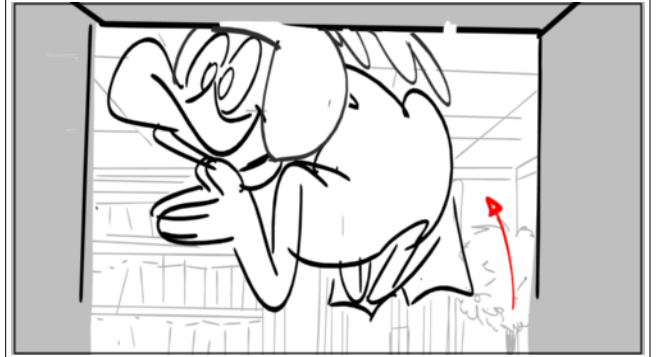
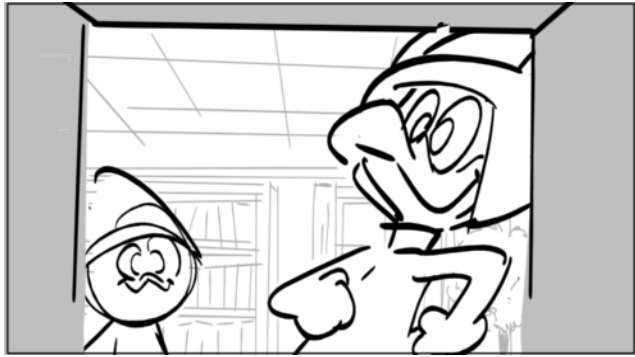

Action Notes

Pierrot jumps in/out

| Scene | Duration | Panel | Duration |
|-------|----------|-------|----------|
| 75 | 05:23 | 13 | 00:06 |

| Scene | Duration | Panel | Duration |
|-------|----------|-------|----------|
| 75 | 05:23 | 14 | 00:08 |

| Scene | Duration | Panel | Duration |
|-------|----------|-------|----------|
| 75 | 05:23 | 15 | 00:08 |



Action Notes

Calimero jumps in/out

| Scene | Duration | Panel | Duration |
|-------|----------|-------|----------|
| 75 | 05:23 | 16 | 00:08 |



| Scene | Duration | Panel | Duration |
|-------|----------|-------|----------|
| 75 | 05:23 | 17 | 00:08 |

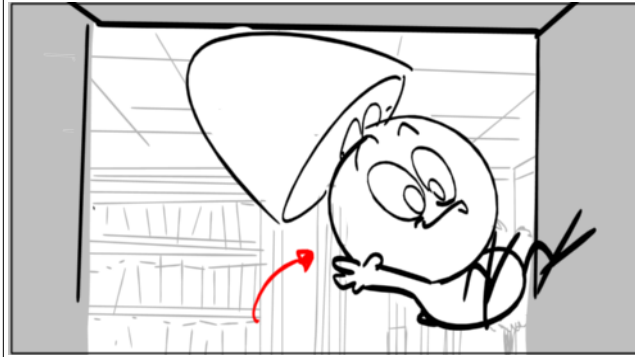

| Scene | Duration | Panel | Duration |
|-------|----------|-------|----------|
| 75 | 05:23 | 18 | 00:08 |

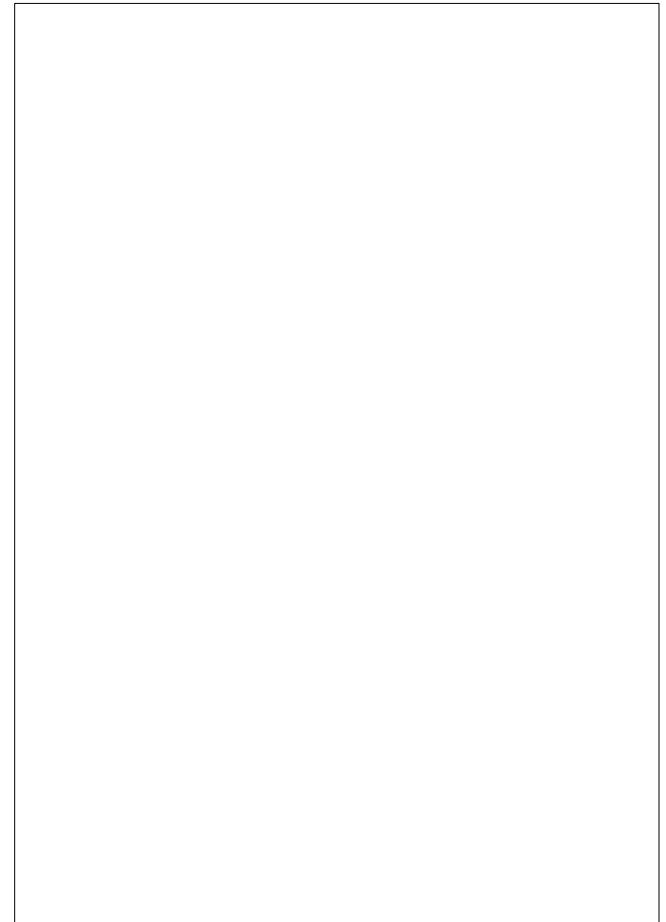
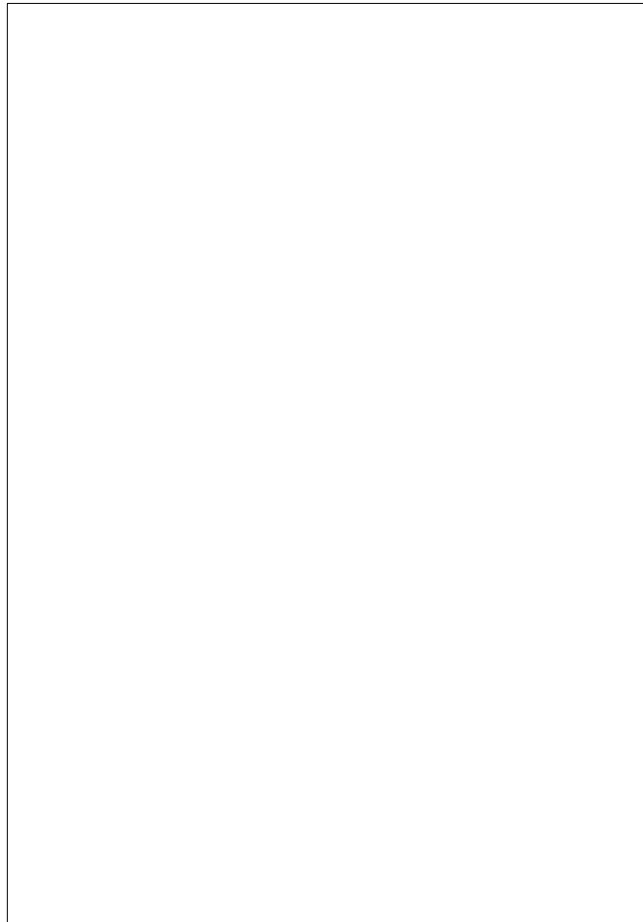
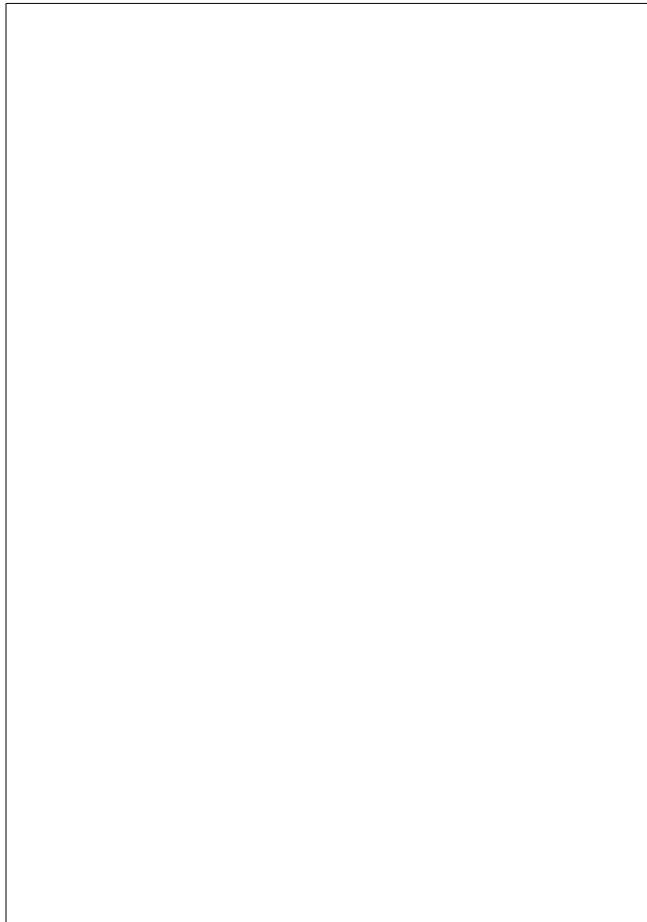



| Scene | Duration | Panel | Duration |
|-------|----------|-------|----------|
| 75 | 05:23 | 19 | 00:08 |

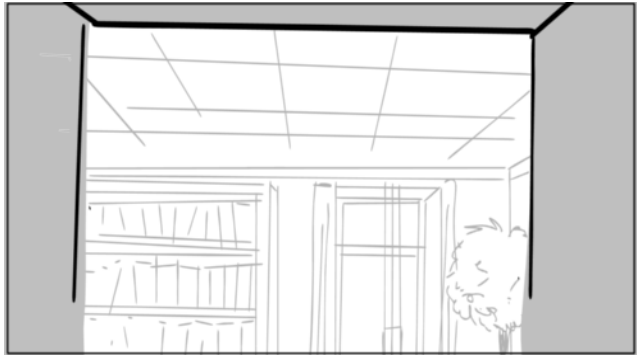

| Scene | Duration | Panel | Duration |
|-------|----------|-------|----------|
| 76 | 03:01 | 1 | 00:07 |

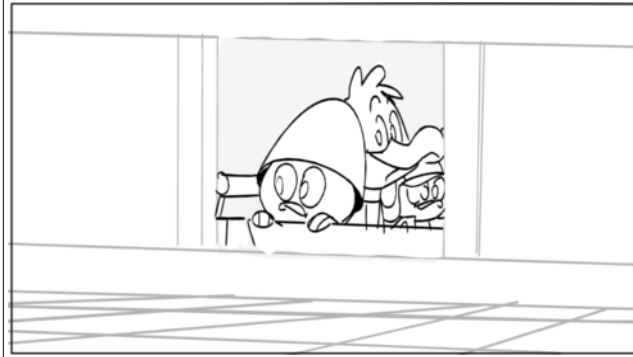

| Scene | Duration | Panel | Duration |
|-------|----------|-------|----------|
| 76 | 03:01 | 2 | 00:11 |

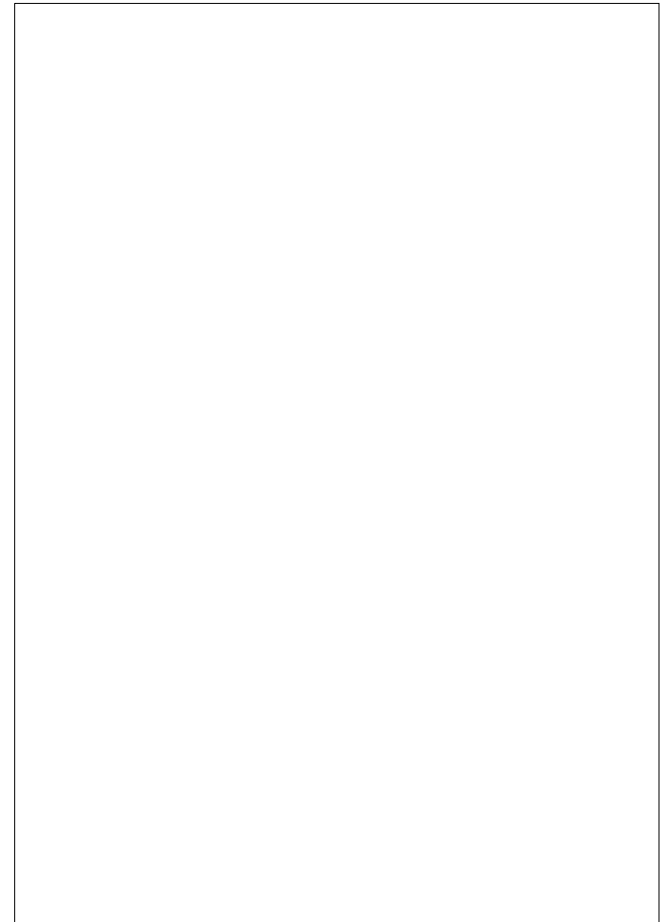
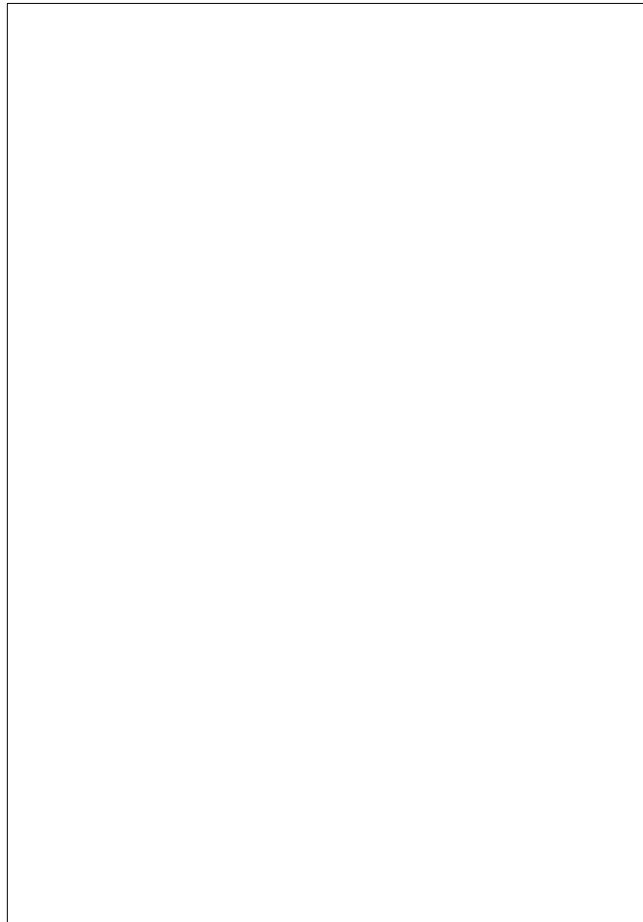
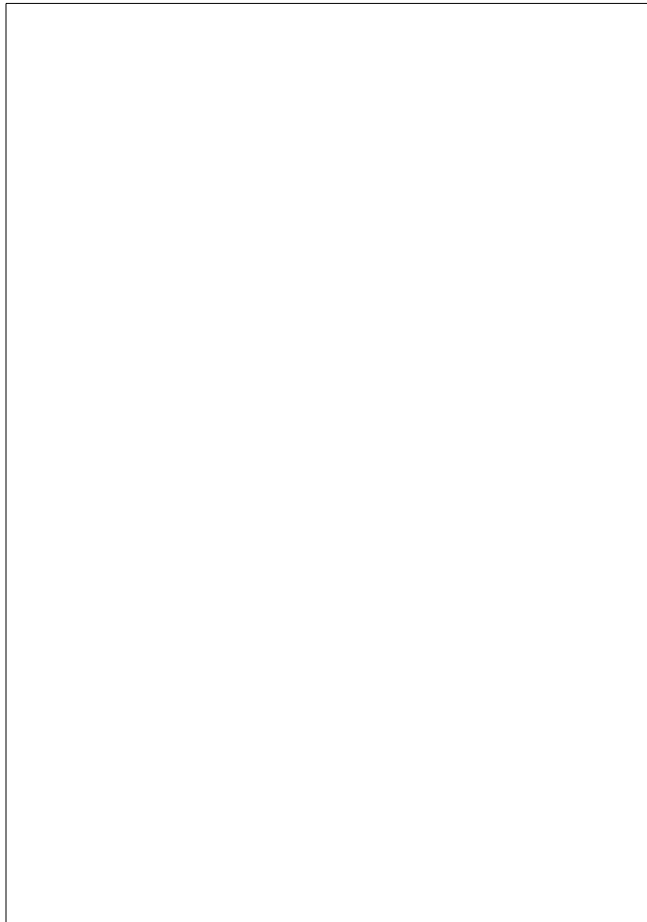
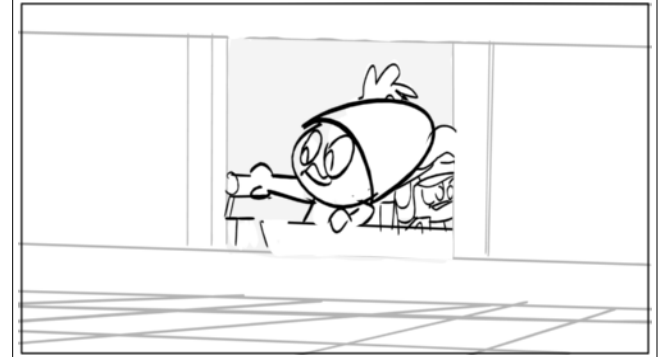



| Scene | Duration | Panel | Duration |
|-------|----------|-------|----------|
| 76 | 03:01 | 3 | 00:08 |

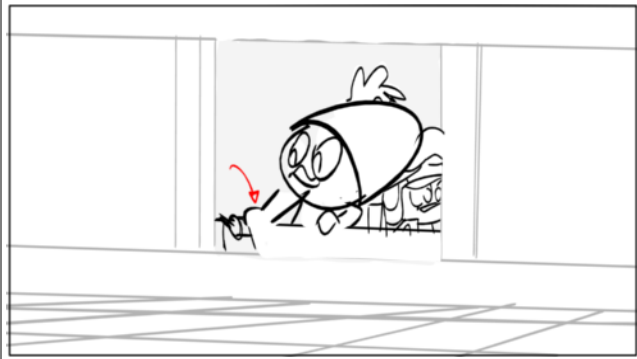

Action Notes

Calimero pushes down the lever

| Scene | Duration | Panel | Duration |
|-------|----------|-------|----------|
| 76 | 03:01 | 4 | 00:14 |

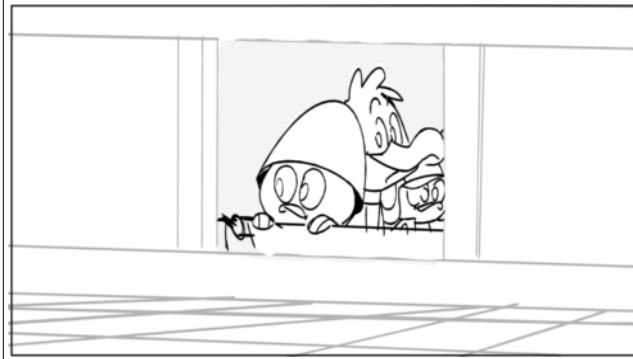

| Scene | Duration | Panel | Duration |
|-------|----------|-------|----------|
| 76 | 03:01 | 5 | 00:09 |

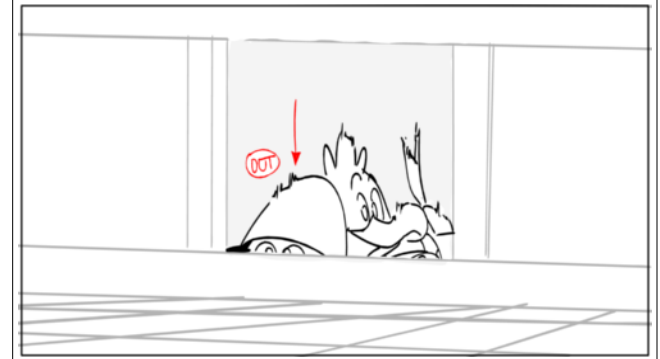

Action Notes

the kids fall out with the wagon



| Scene | Duration | Panel | Duration |
|-------|----------|-------|----------|
| 76 | 03:01 | 6 | 00:09 |

| Scene | Duration | Panel | Duration |
|-------|----------|-------|----------|
| 76 | 03:01 | 7 | 00:09 |

| Scene | Duration | Panel | Duration |
|-------|----------|-------|----------|
| 76 | 03:01 | 8 | 00:09 |

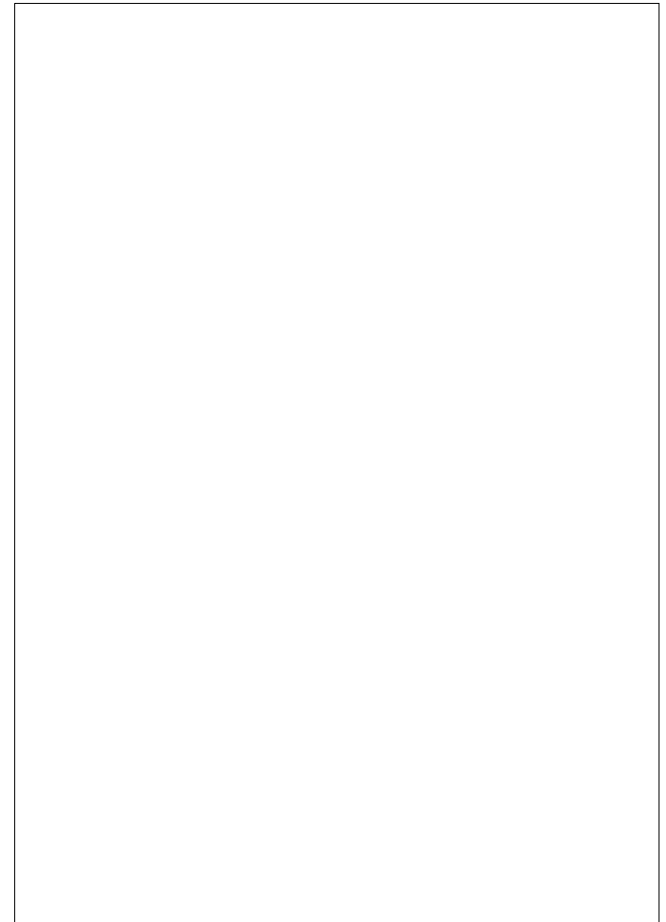
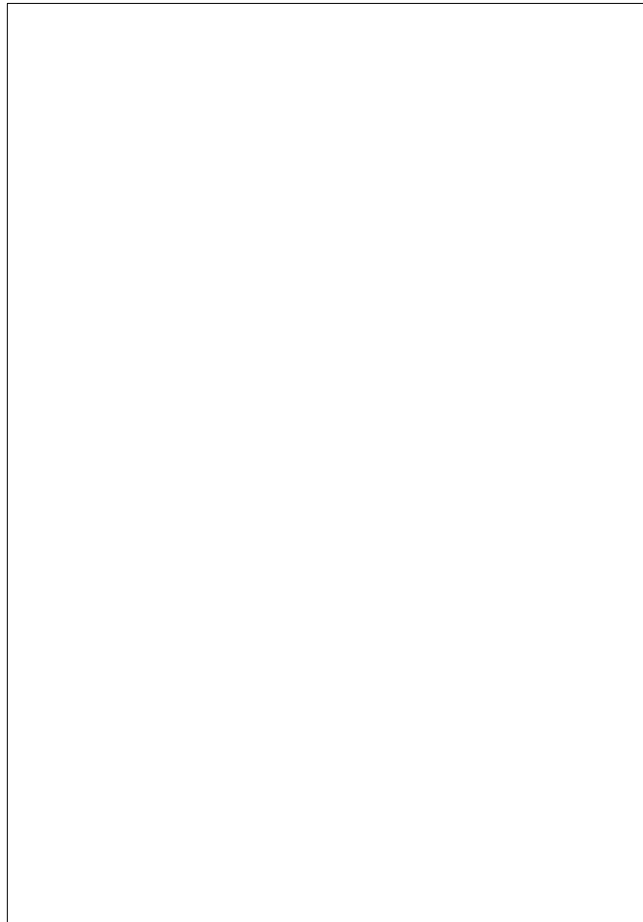
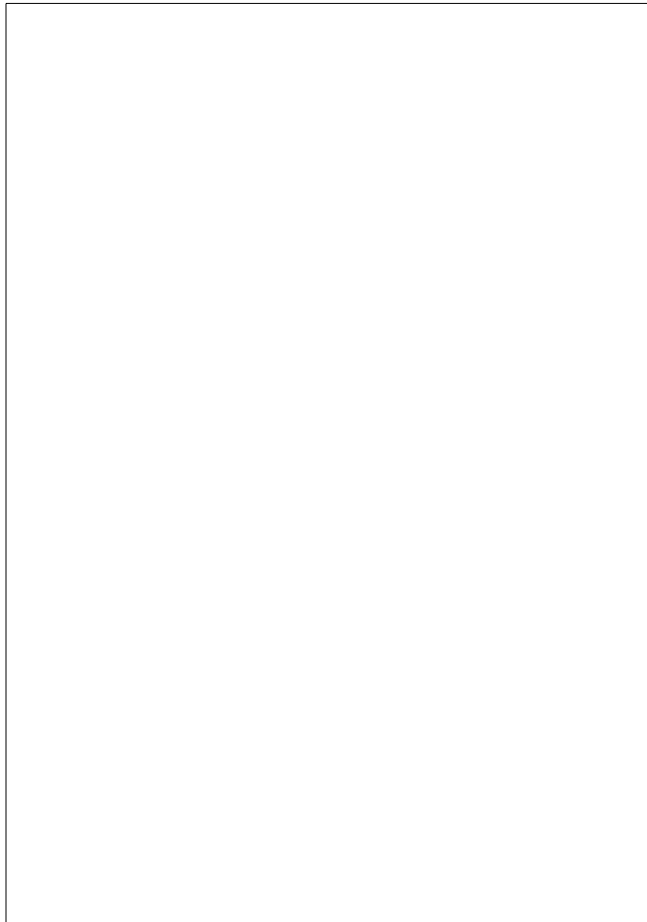
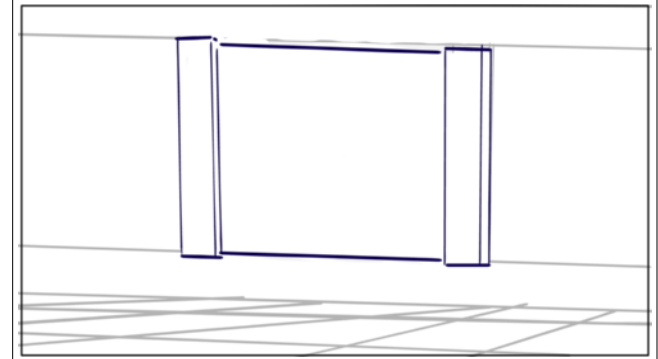
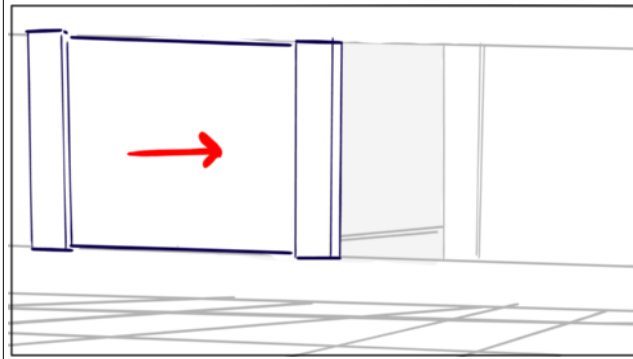
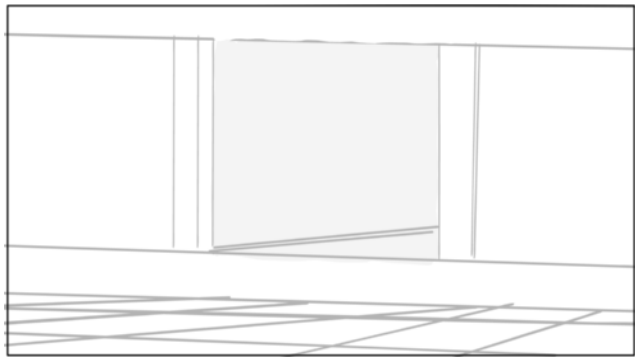



| | | | |
|-------|----------|-------|----------|
| Scene | Duration | Panel | Duration |
| 77 | 08:04 | 1 | 00:12 |

NO PANEL

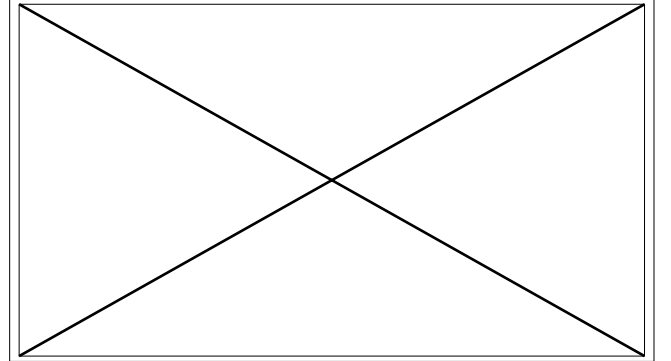
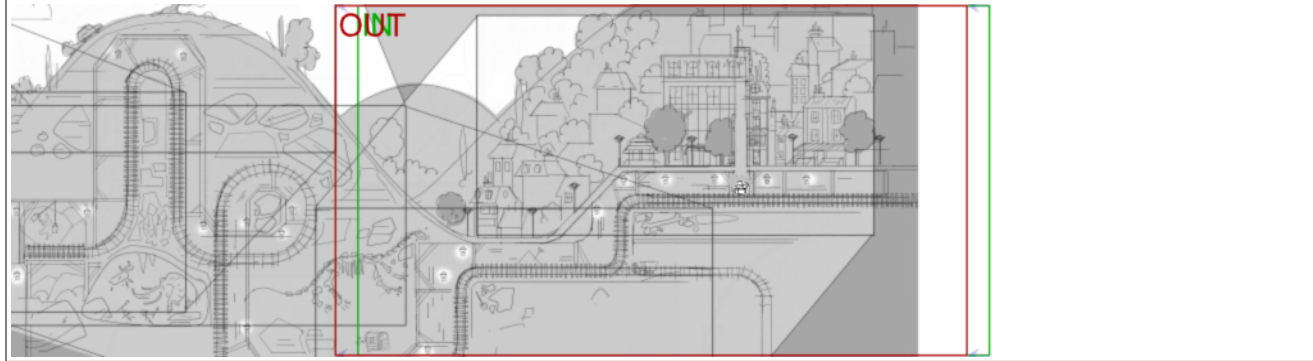

Action Notes

reut sequence
follow on kids on trackgoing from home to mill

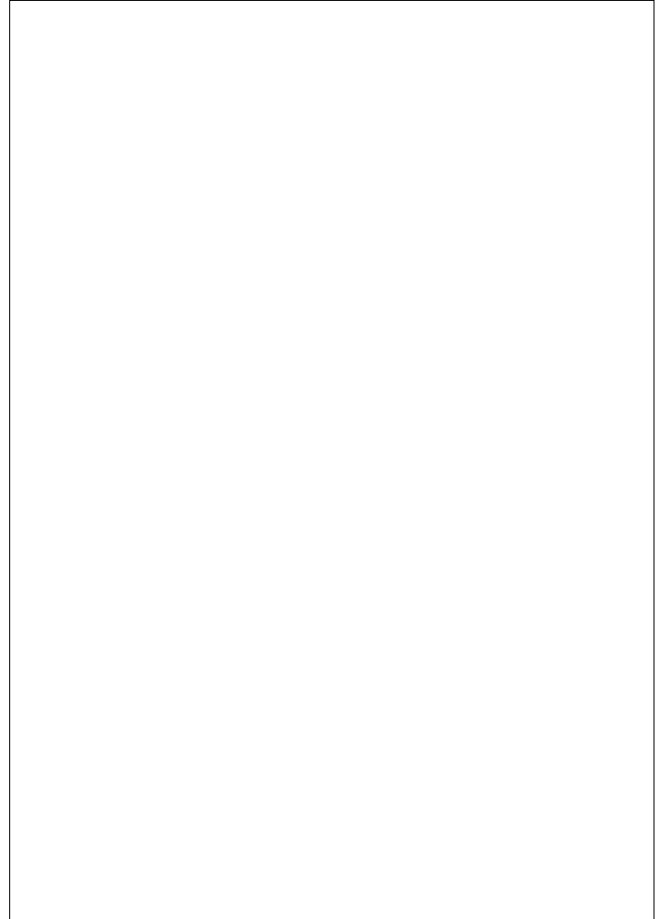



| | | | |
|-------|----------|-------|----------|
| Scene | Duration | Panel | Duration |
| 77 | 08:04 | 2 | 00:12 |

NO PANEL

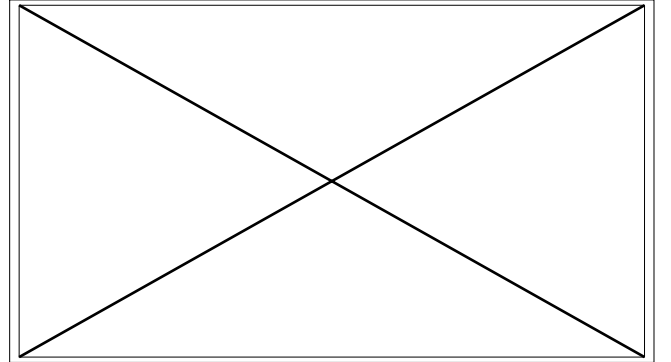
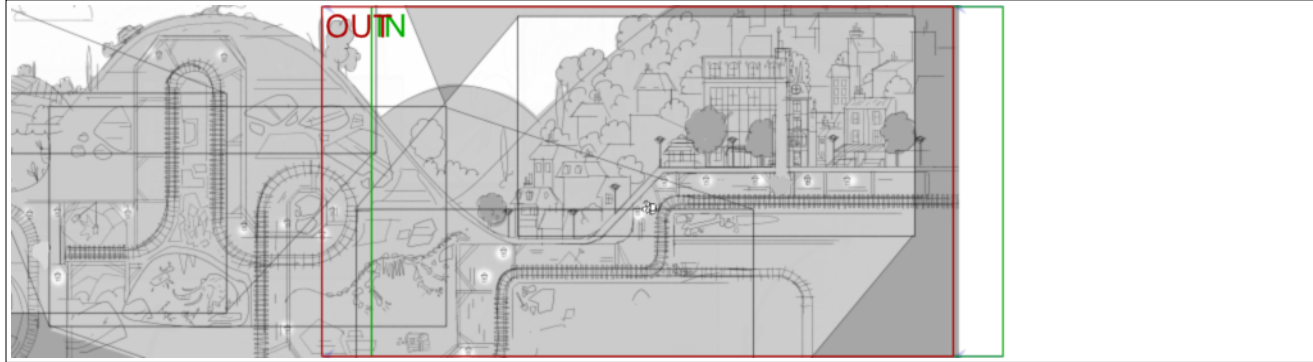

Action Notes

reut sequence
follow on kids on trackgoing from home to mill

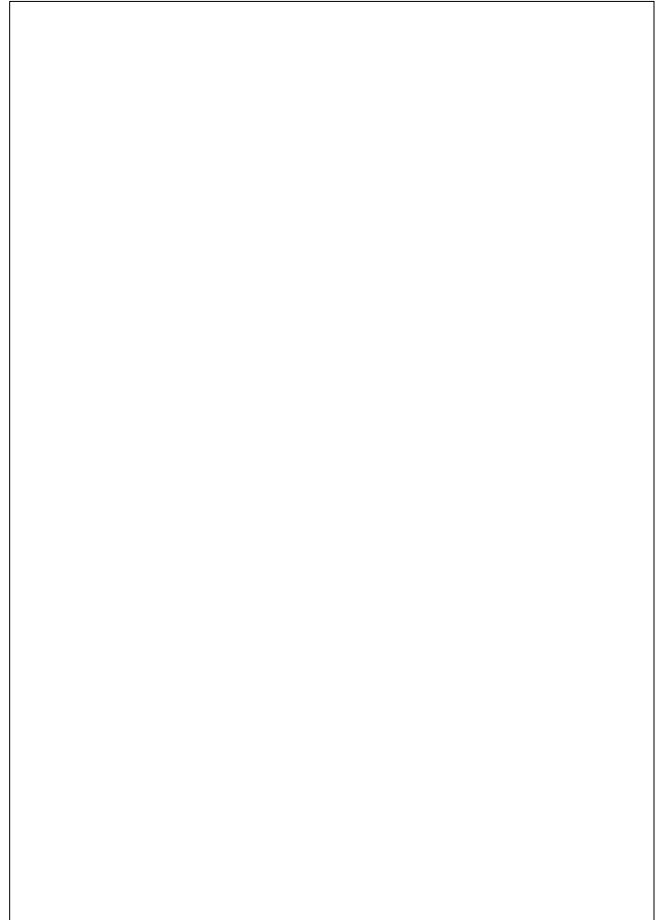



| | | | |
|-------|----------|-------|----------|
| Scene | Duration | Panel | Duration |
| 77 | 08:04 | 3 | 00:12 |

NO PANEL

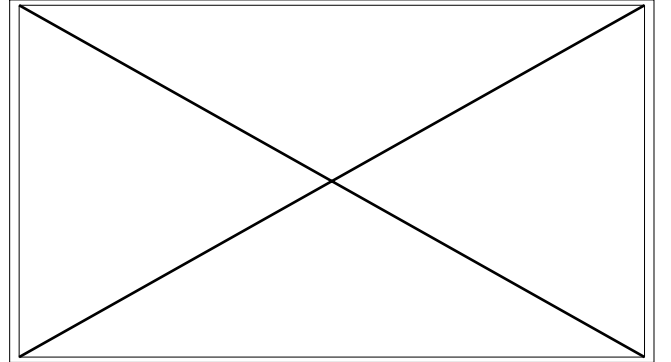
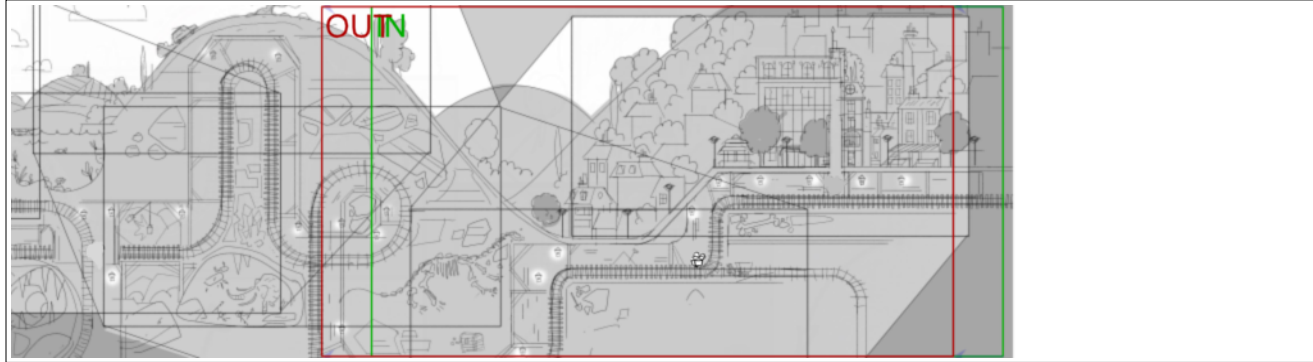

Action Notes

reut sequence
follow on kids on trackgoing from home to mill

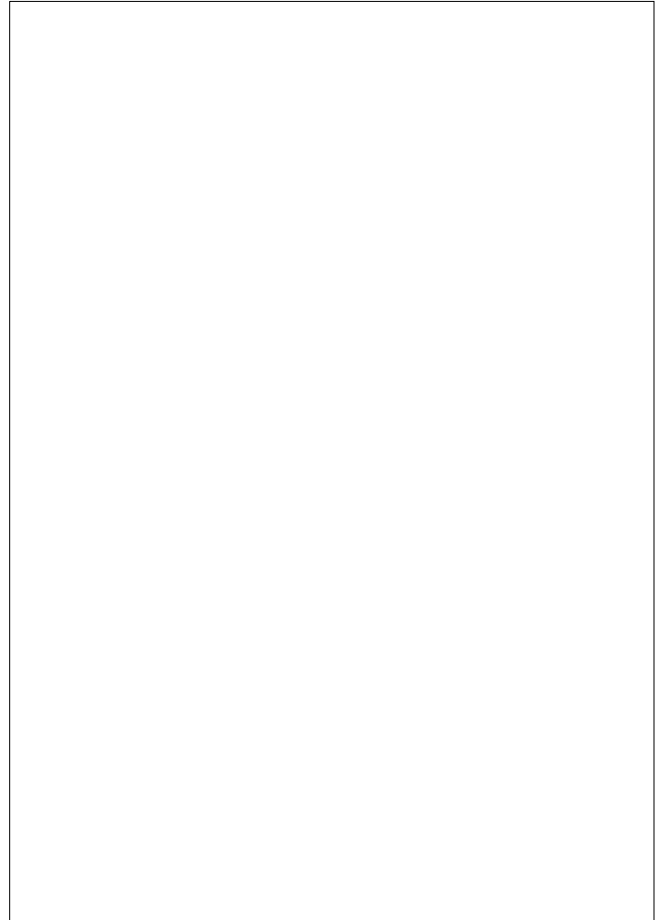



| | | | |
|-------|----------|-------|----------|
| Scene | Duration | Panel | Duration |
| 77 | 08:04 | 4 | 00:12 |

NO PANEL

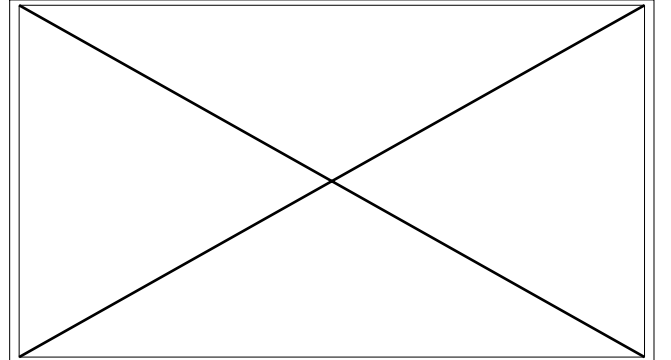
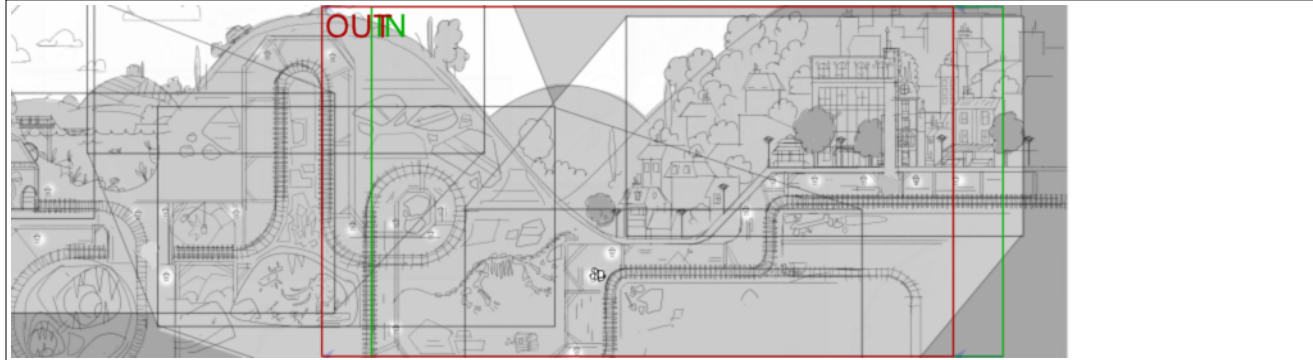

Action Notes

reut sequence
follow on kids on trackgoing from home to mill

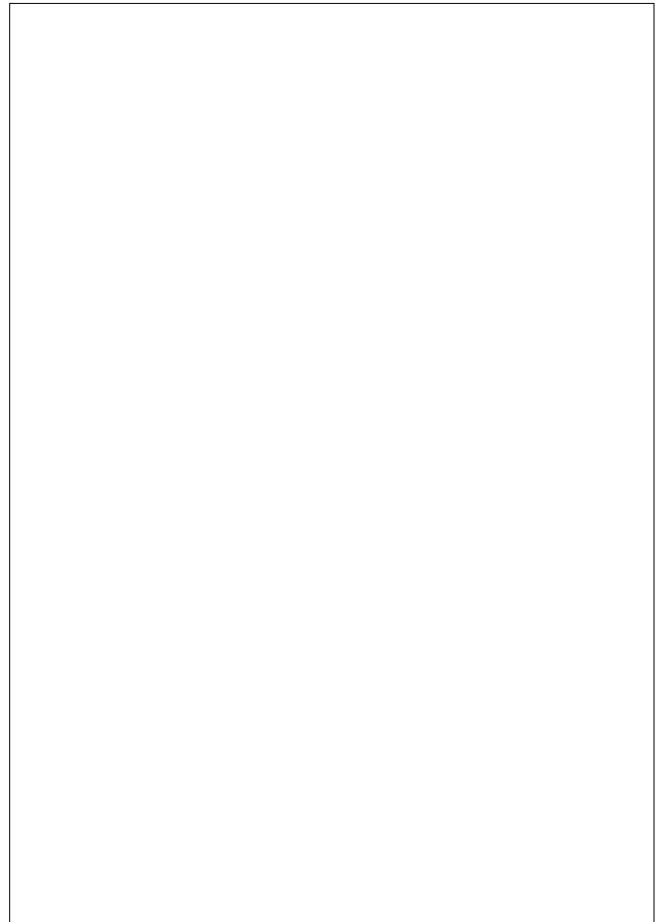



| | | | |
|-------|----------|-------|----------|
| Scene | Duration | Panel | Duration |
| 77 | 08:04 | 5 | 00:12 |

NO PANEL

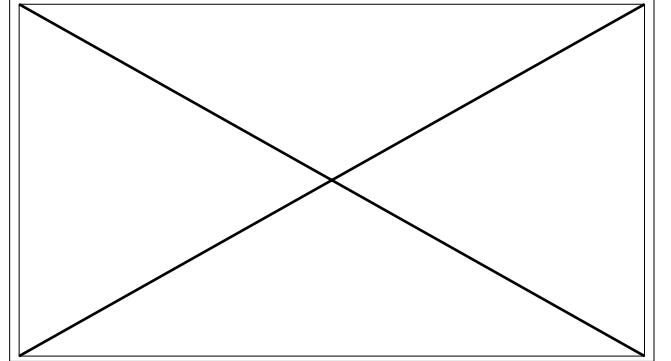
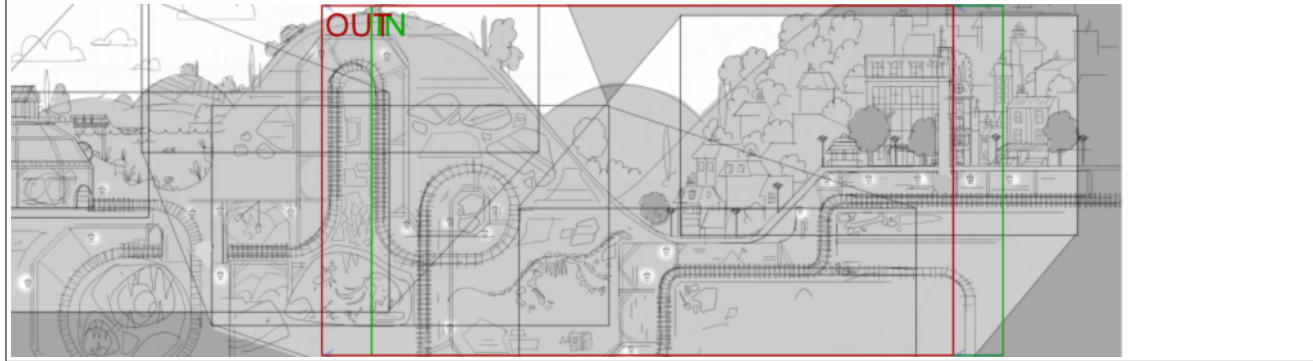

Action Notes

reut sequence
follow on kids on trackgoing from home to mill

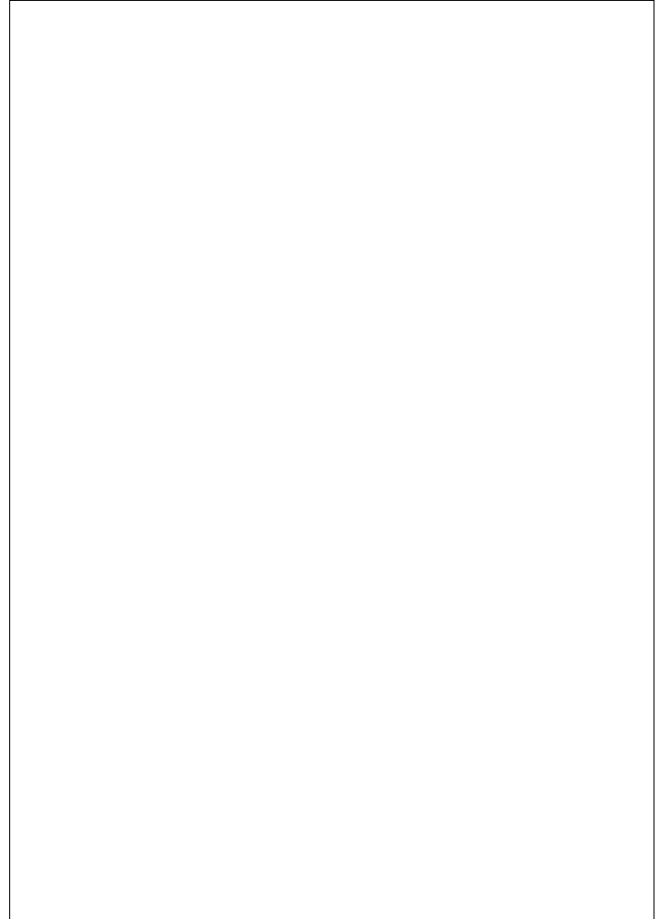



| | | | |
|-------|----------|-------|----------|
| Scene | Duration | Panel | Duration |
| 77 | 08:04 | 6 | 00:12 |

NO PANEL

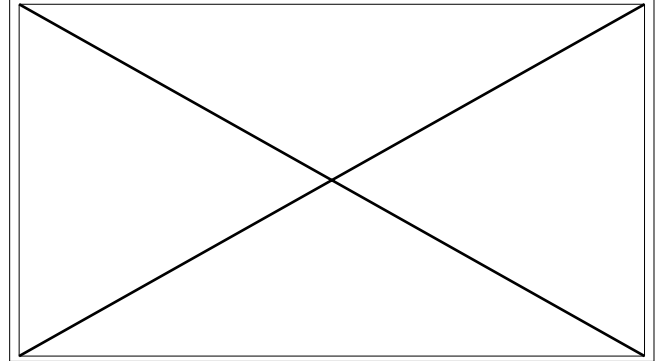
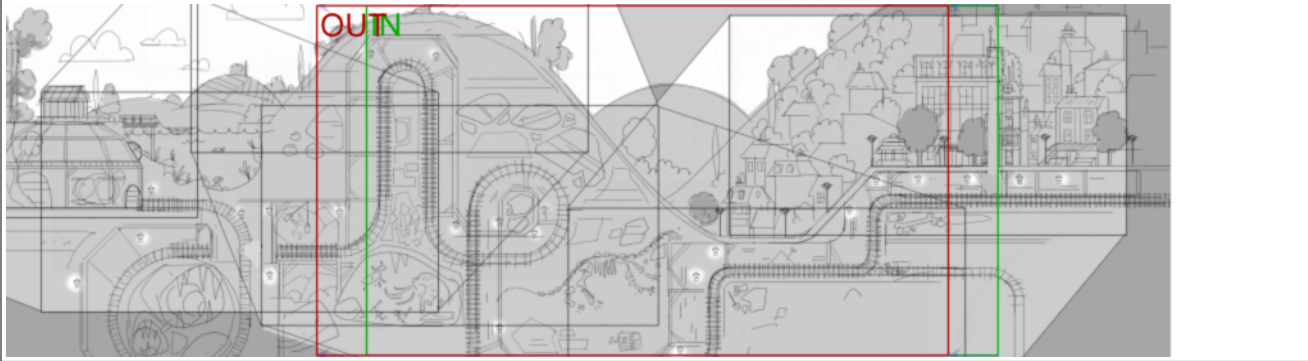

Action Notes

reut sequence
follow on kids on trackgoing from home to mill

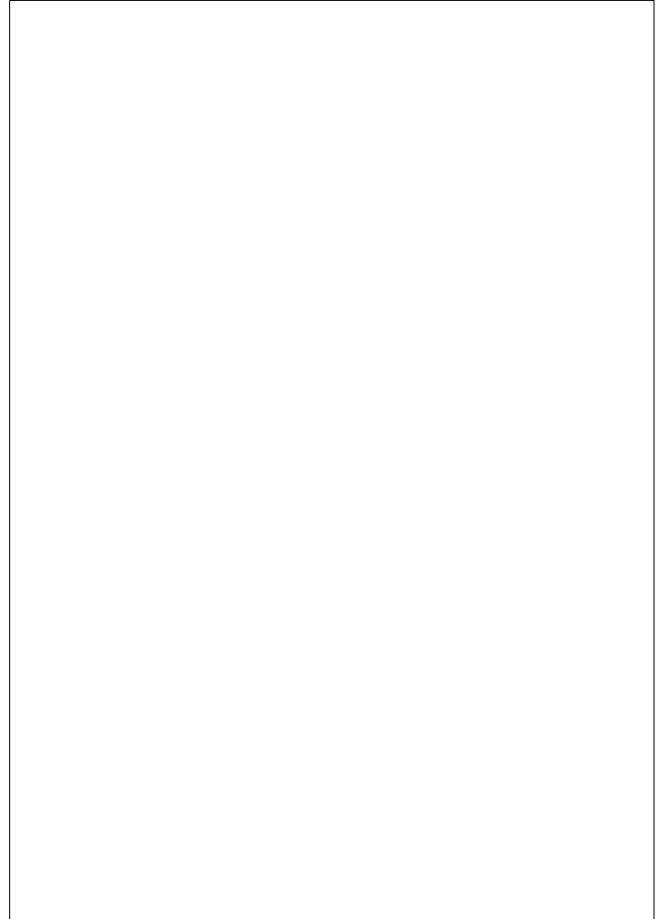



| | | | |
|-------|----------|-------|----------|
| Scene | Duration | Panel | Duration |
| 77 | 08:04 | 7 | 00:12 |

NO PANEL

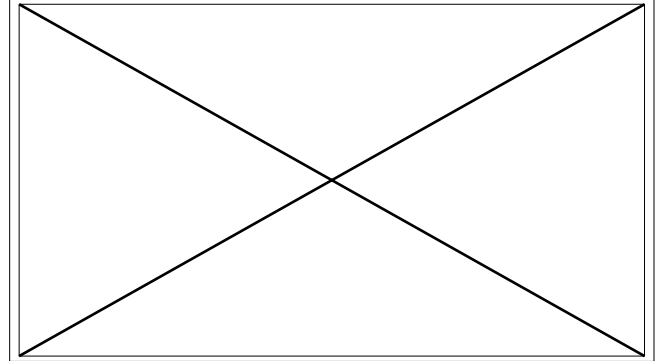
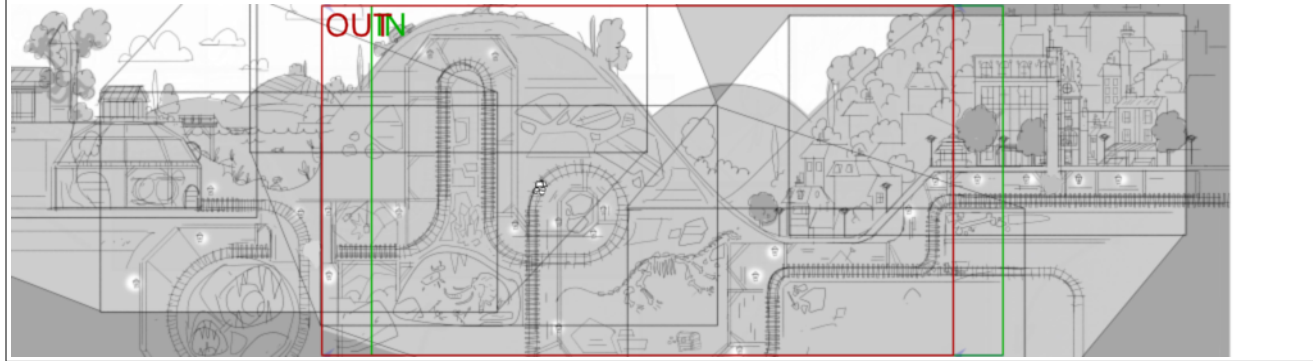

Action Notes

reut sequence
follow on kids on trackgoing from home to mill

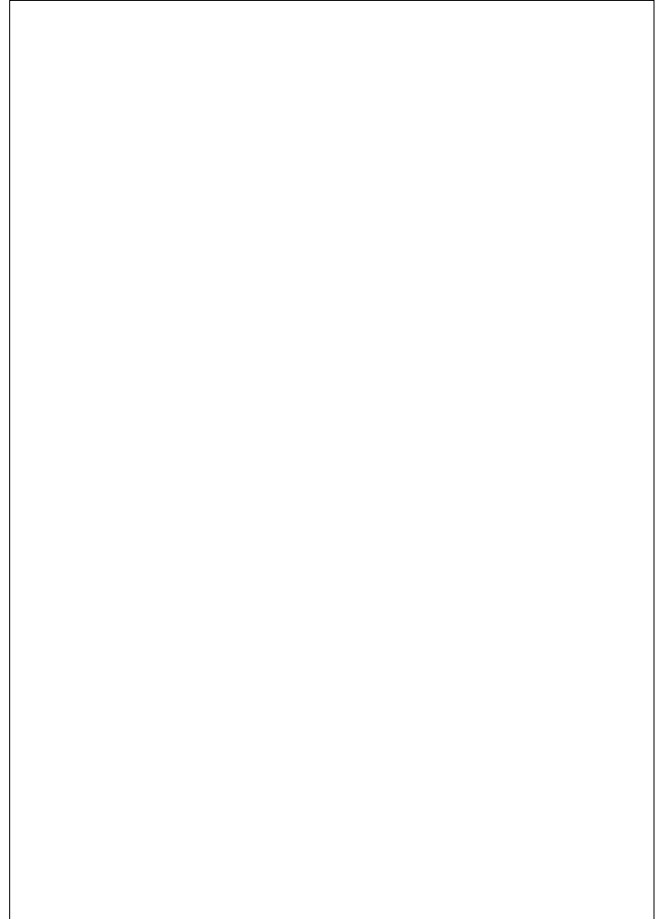



| | | | |
|-------|----------|-------|----------|
| Scene | Duration | Panel | Duration |
| 77 | 08:04 | 8 | 00:12 |

NO PANEL

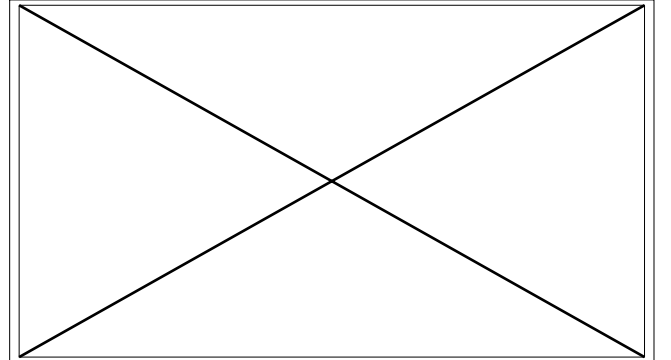
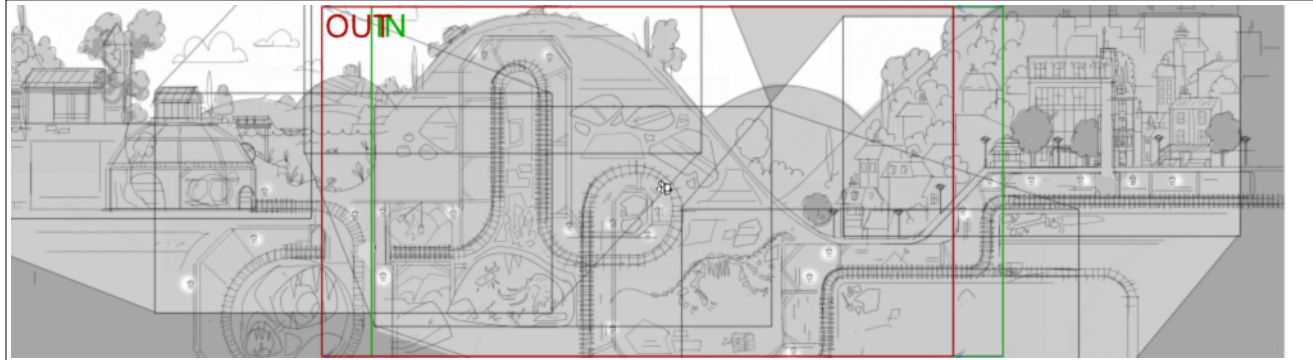

Action Notes

reut sequence
follow on kids on trackgoing from home to mill

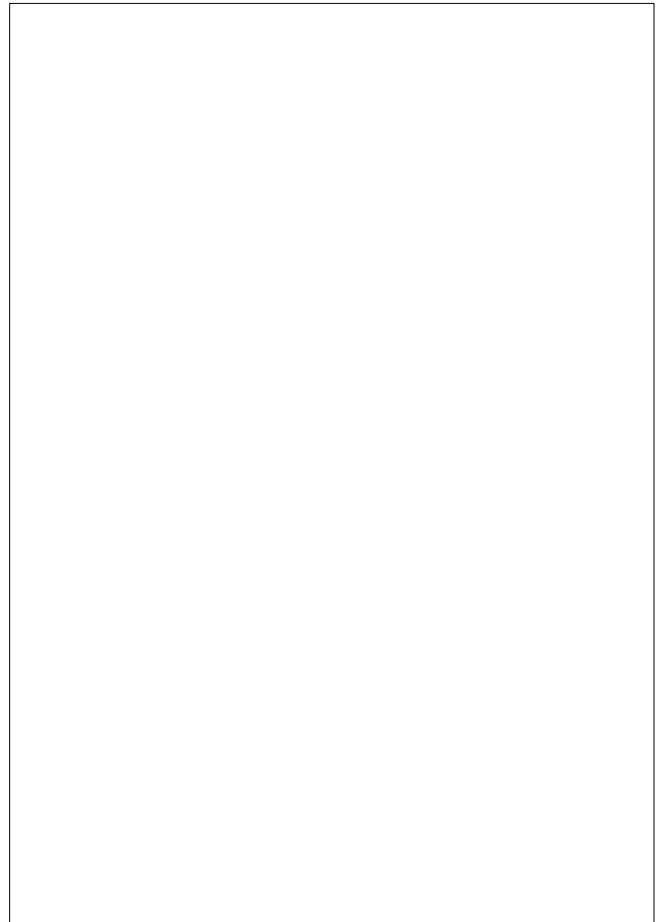



| | | | |
|-------|----------|-------|----------|
| Scene | Duration | Panel | Duration |
| 77 | 08:04 | 9 | 00:12 |

NO PANEL

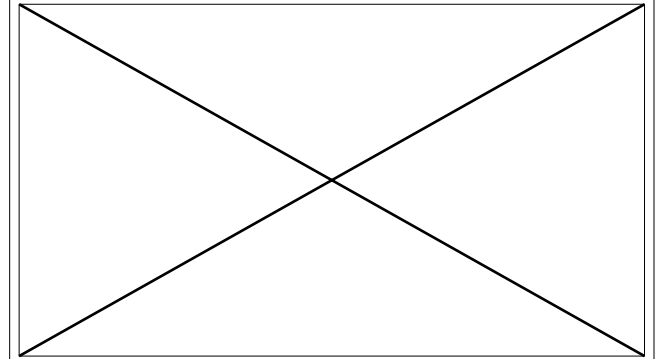
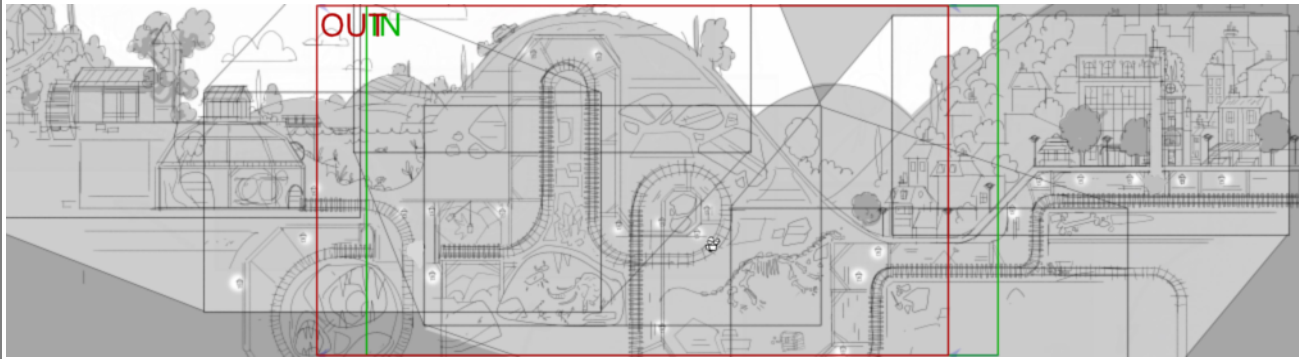

Action Notes

reut sequence
follow on kids on trackgoing from home to mill

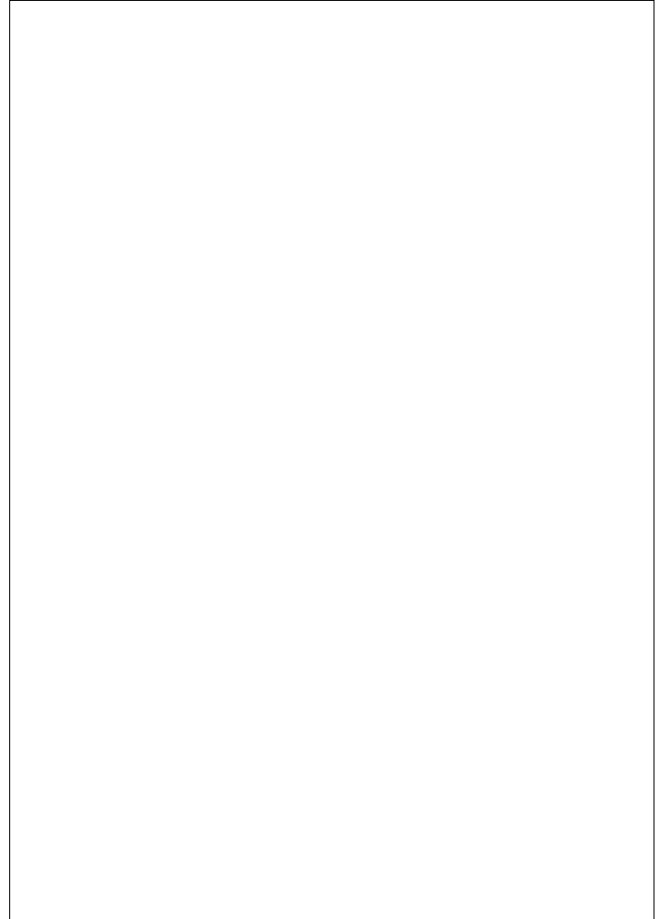



| | | | |
|-------|----------|-------|----------|
| Scene | Duration | Panel | Duration |
| 77 | 08:04 | 10 | 00:12 |

NO PANEL

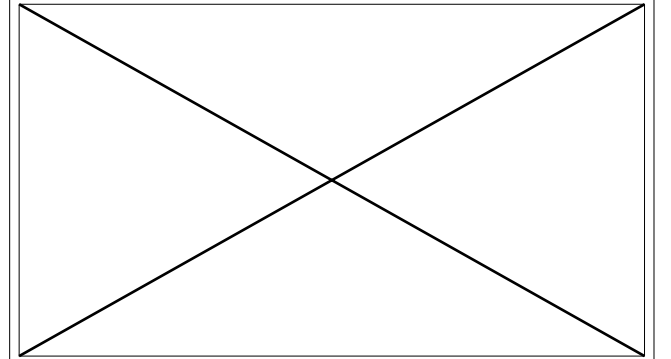
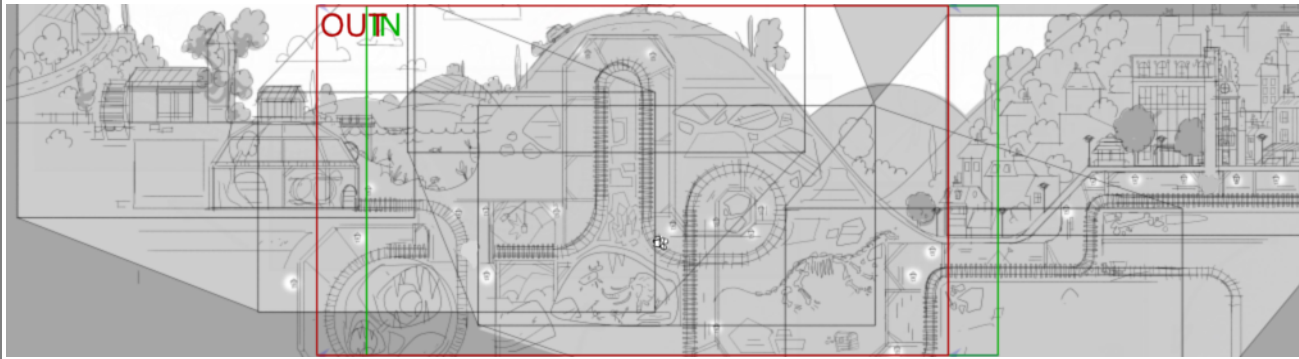

Action Notes

reut sequence
follow on kids on trackgoing from home to mill

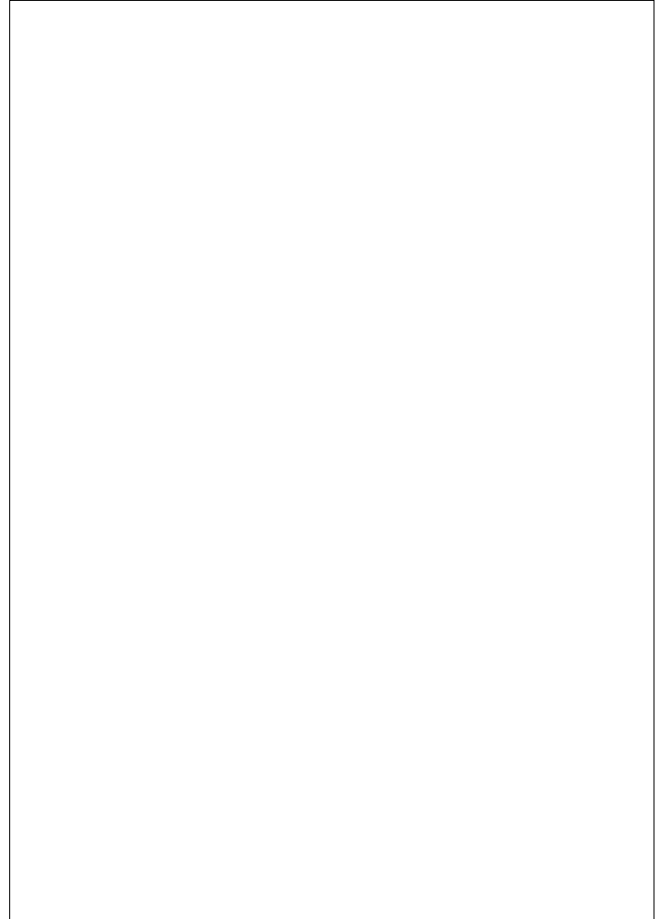



| | | | |
|-------|----------|-------|----------|
| Scene | Duration | Panel | Duration |
| 77 | 08:04 | 11 | 00:12 |

NO PANEL

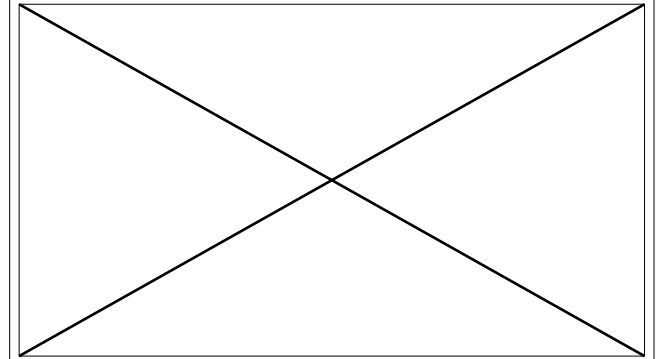
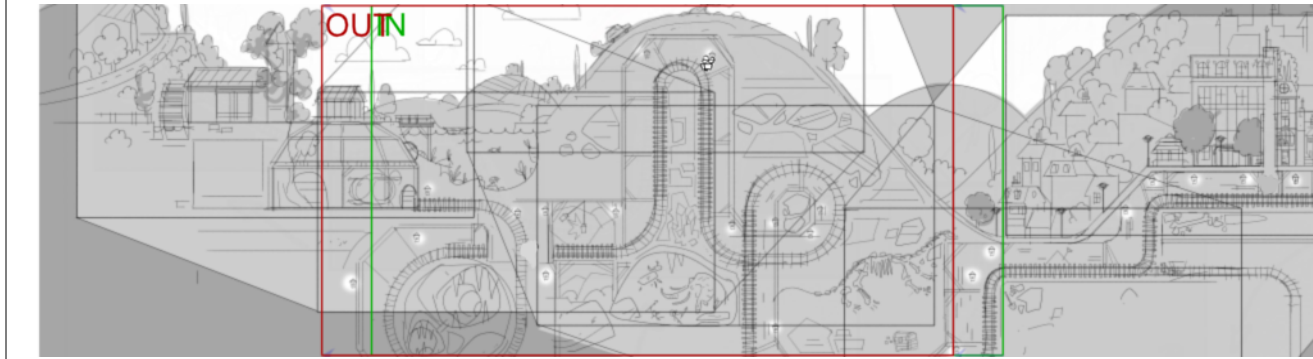

Action Notes

reut sequence
follow on kids on trackgoing from home to mill

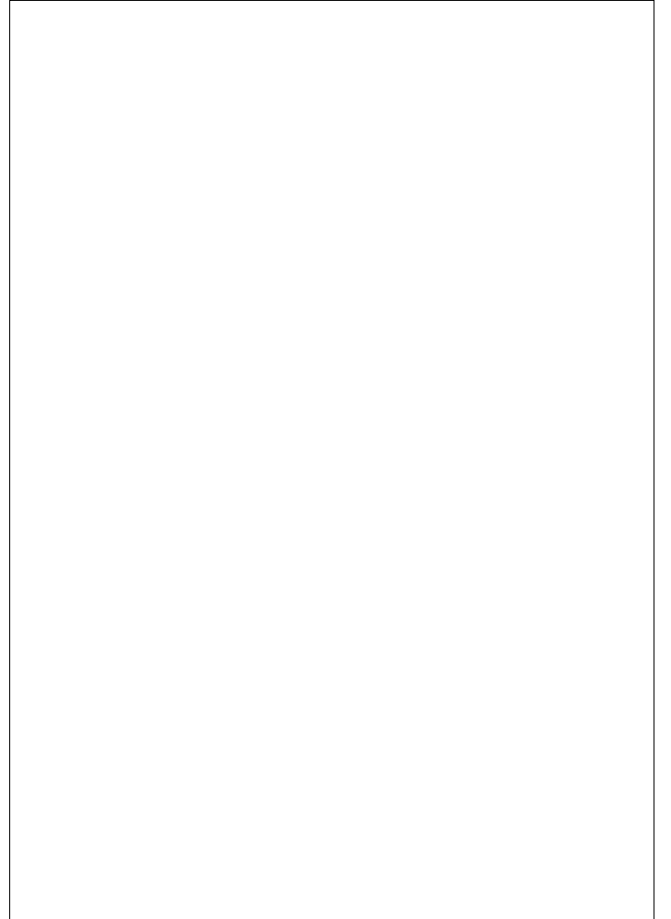



| | | | |
|-------|----------|-------|----------|
| Scene | Duration | Panel | Duration |
| 77 | 08:04 | 12 | 00:12 |

NO PANEL

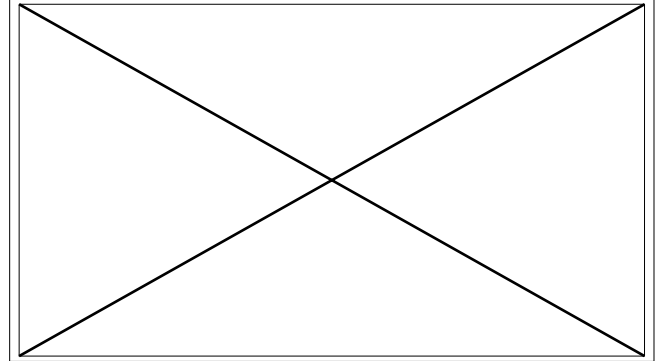
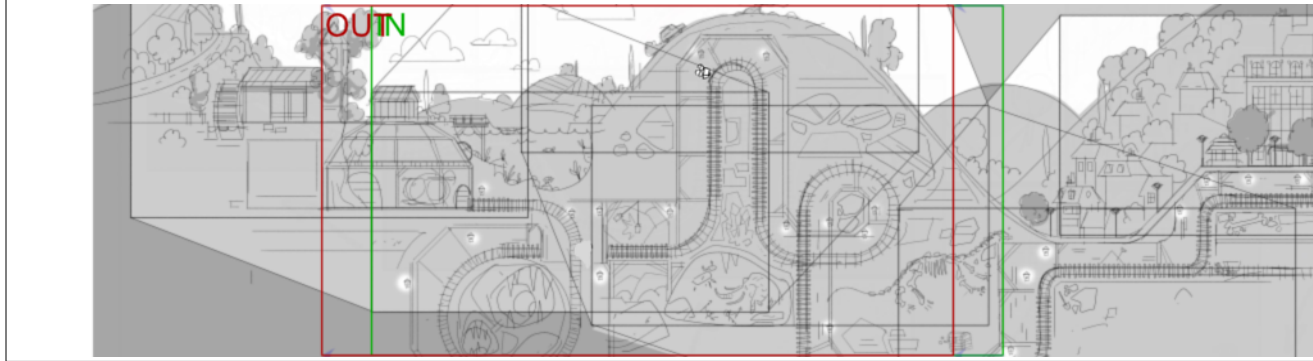

Action Notes

reut sequence
follow on kids on trackgoing from home to mill

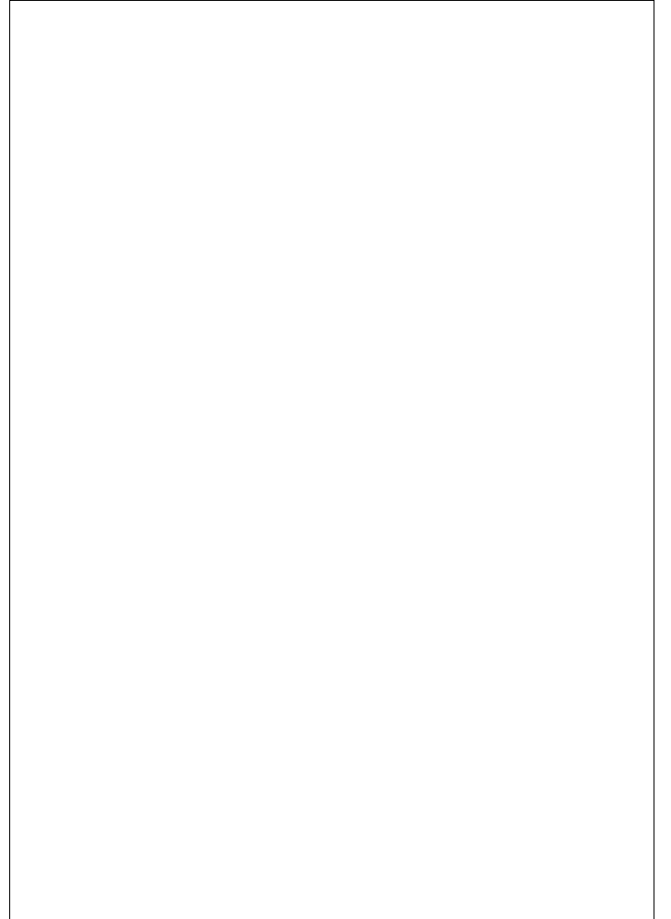



| | | | |
|-------|----------|-------|----------|
| Scene | Duration | Panel | Duration |
| 77 | 08:04 | 13 | 00:12 |

NO PANEL

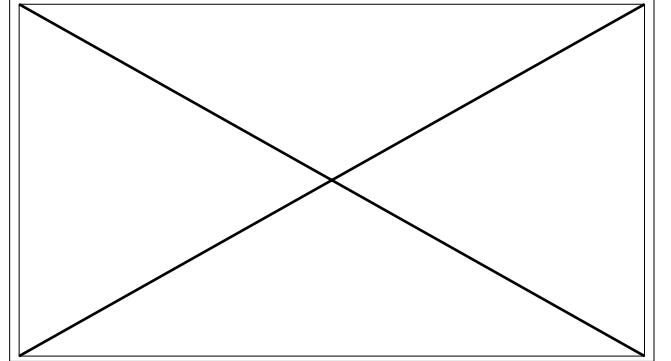
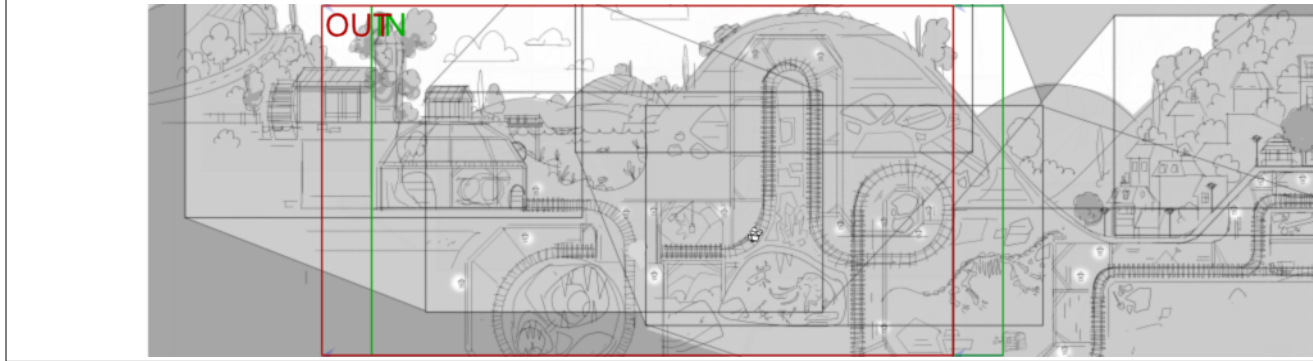

Action Notes
reut sequence
follow on kids on trackgoing from home to mill

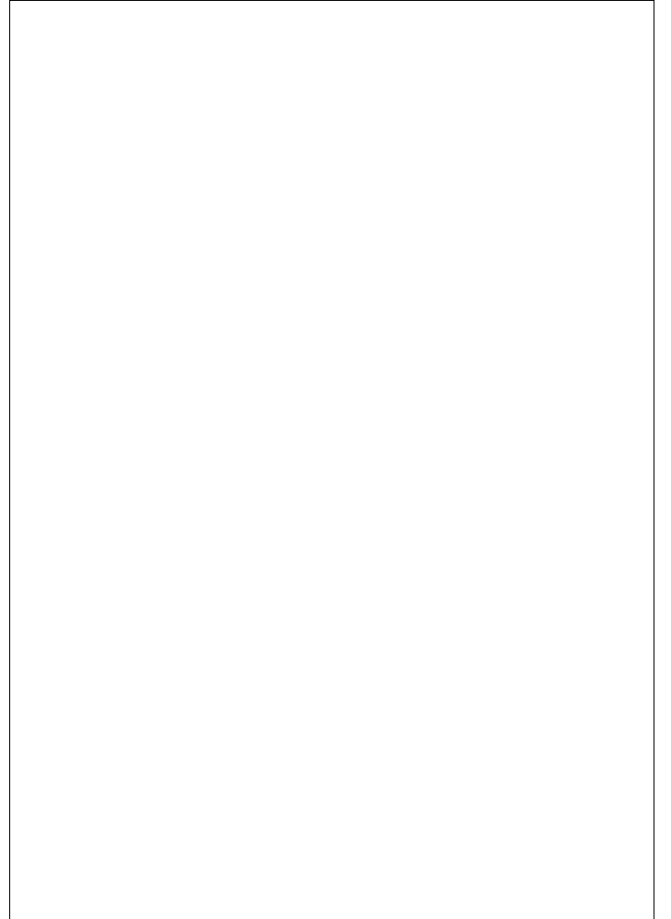



| | | | |
|-------|----------|-------|----------|
| Scene | Duration | Panel | Duration |
| 77 | 08:04 | 14 | 00:12 |

NO PANEL

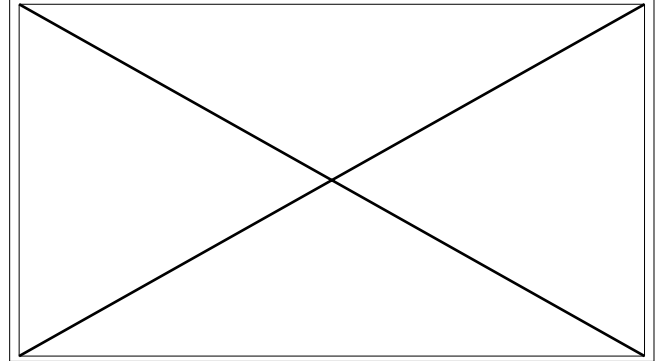
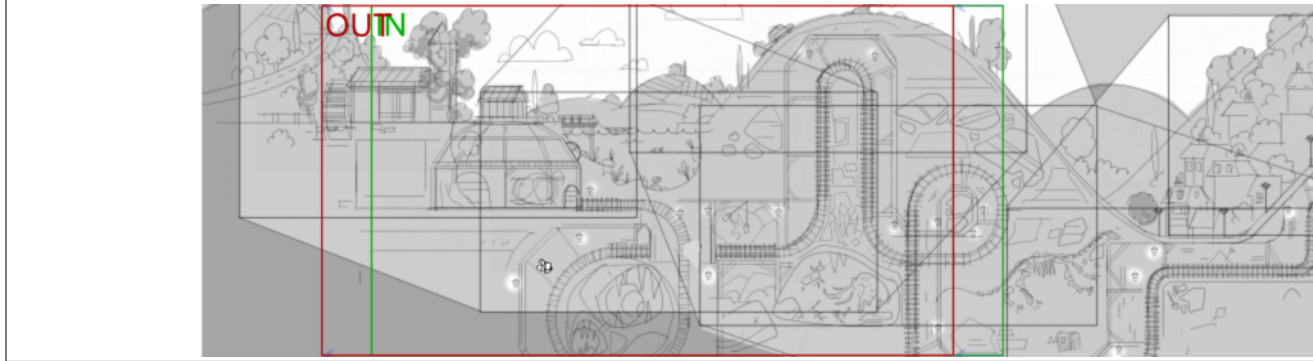

Action Notes

reut sequence
follow on kids on trackgoing from home to mill

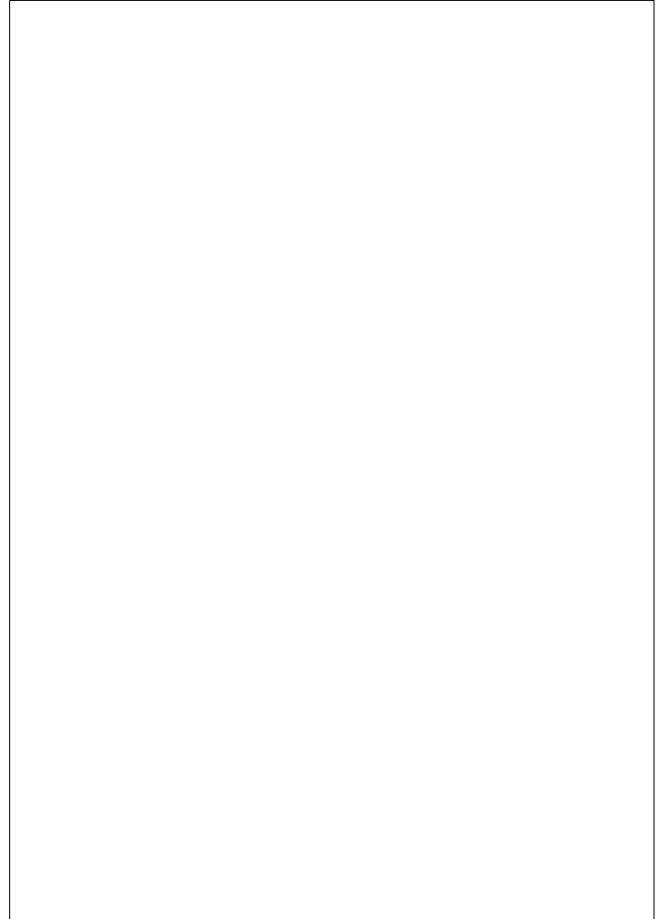



| | | | |
|-------|----------|-------|----------|
| Scene | Duration | Panel | Duration |
| 77 | 08:04 | 15 | 00:12 |

NO PANEL

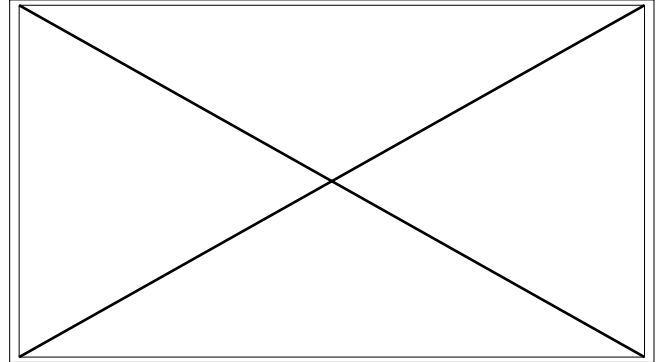
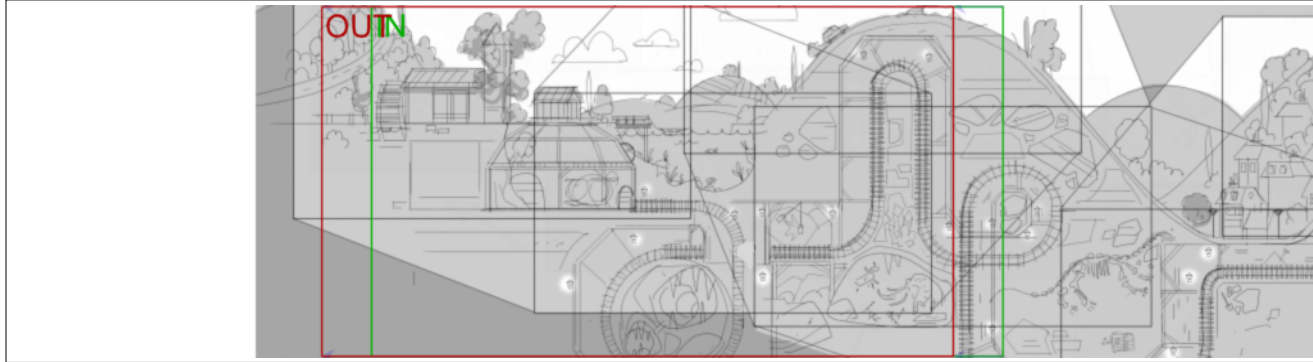

Action Notes

reut sequence
follow on kids on trackgoing from home to mill

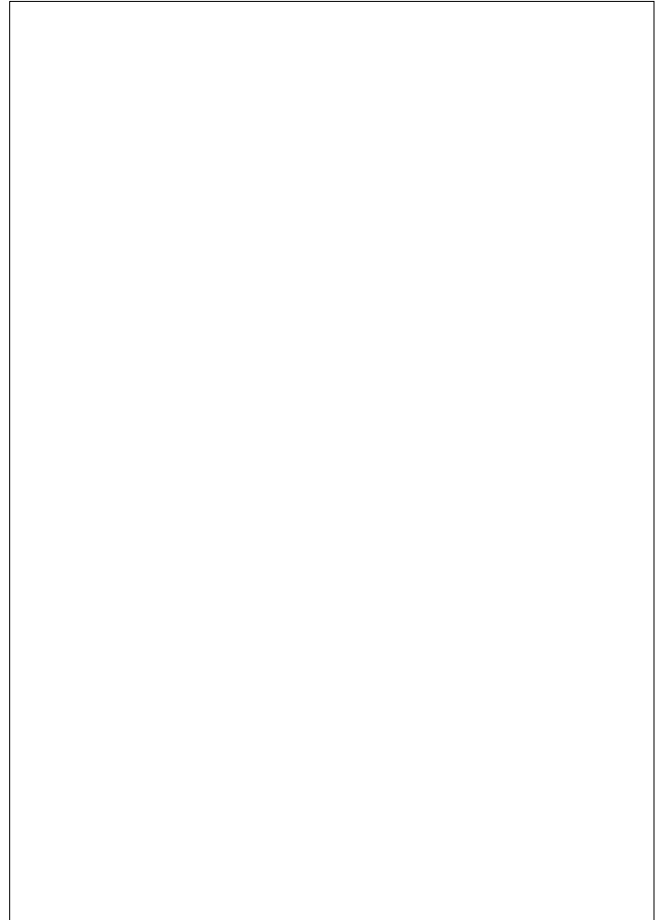



| Scene | Duration | Panel | Duration |
|-------|----------|-------|----------|
| 77 | 08:04 | 16 | 00:12 |

| Scene | Duration | Panel | Duration |
|-------|----------|-------|----------|
| 77 | 08:04 | 17 | 00:12 |

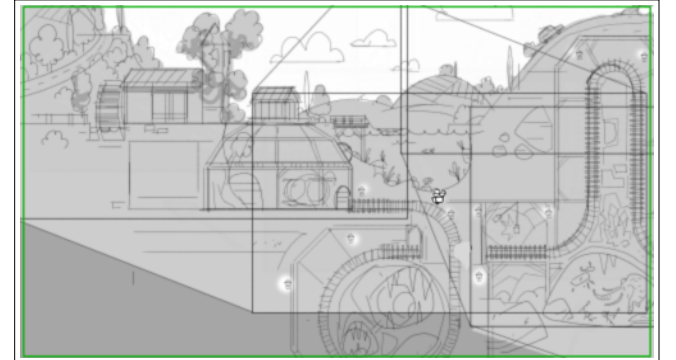
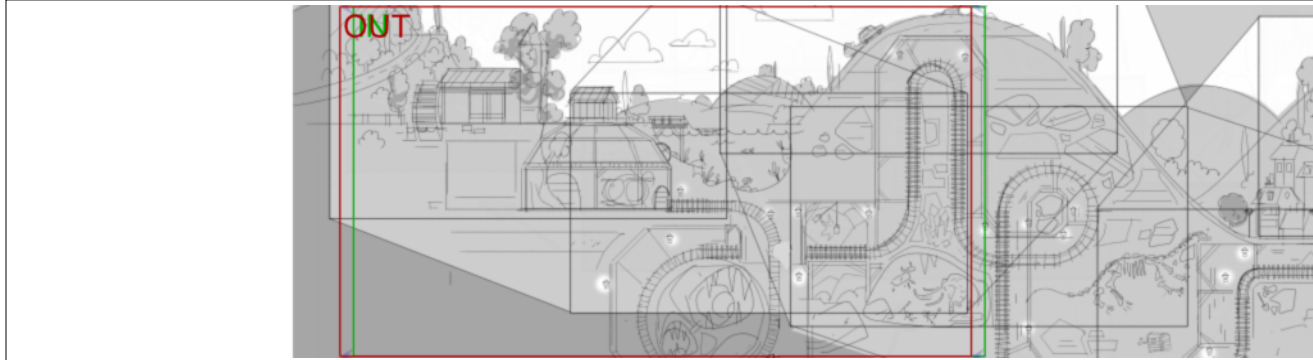

Action Notes

reut sequence
follow on kids on trackgoing from home to mill

Action Notes

reut sequence
follow on kids on trackgoing from home to mill



| Scene | Duration | Panel | Duration |
|-------|----------|-------|----------|
| 78 | 06:19 | 1 | 00:09 |

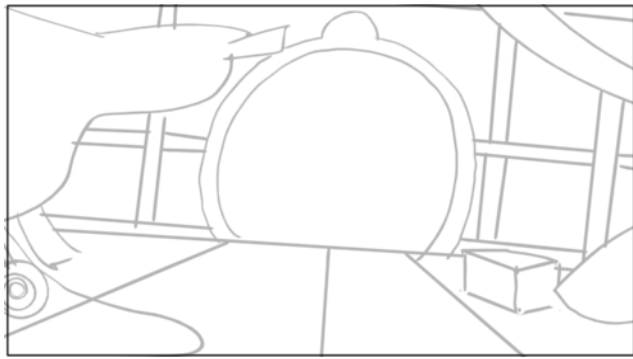

Action Notes

later inside mill day

| Scene | Duration | Panel | Duration |
|-------|----------|-------|----------|
| 78 | 06:19 | 2 | 00:14 |

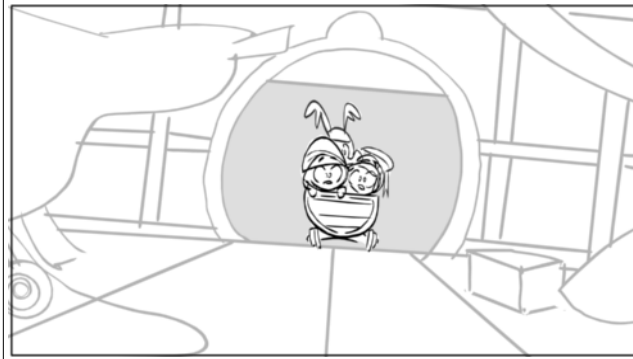

Action Notes

door open
truck in fast

| Scene | Duration | Panel | Duration |
|-------|----------|-------|----------|
| 78 | 06:19 | 3 | 00:09 |

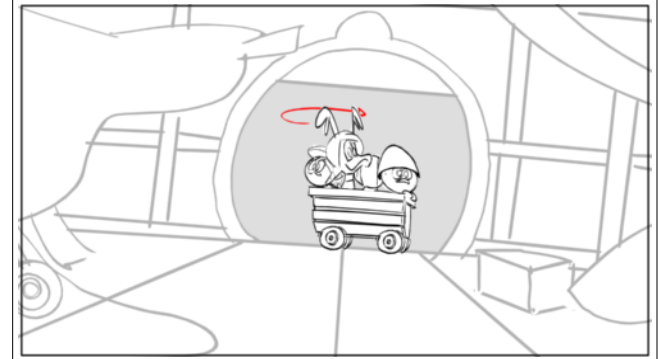

Action Notes

door open
truck in fast

| Scene | Duration | Panel | Duration |
|-------|----------|-------|----------|
| 78 | 06:19 | 4 | 00:11 |

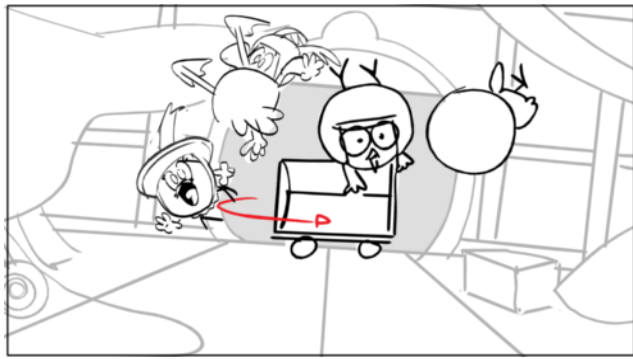

Action Notes

truck u turn
kids busted out of trunk

| Scene | Duration | Panel | Duration |
|-------|----------|-------|----------|
| 78 | 06:19 | 5 | 00:07 |

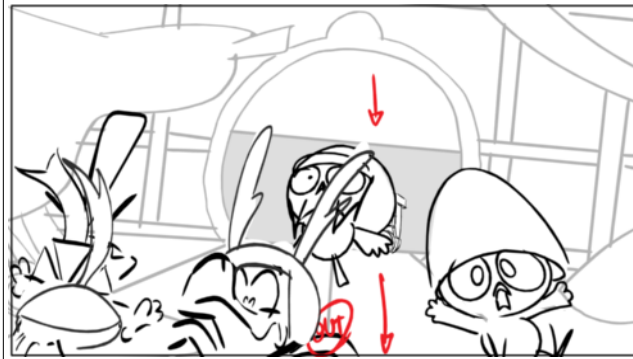

Action Notes

door close
kids fall out

| Scene | Duration | Panel | Duration |
|-------|----------|-------|----------|
| 78 | 06:19 | 6 | 01:00 |

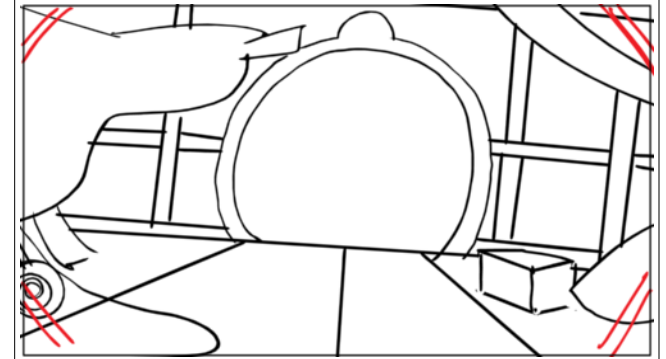

Action Notes

shaje cam
hit floor

| Scene | Duration | Panel | Duration |
|-------|----------|-------|----------|
| 78 | 06:19 | 7 | 00:20 |

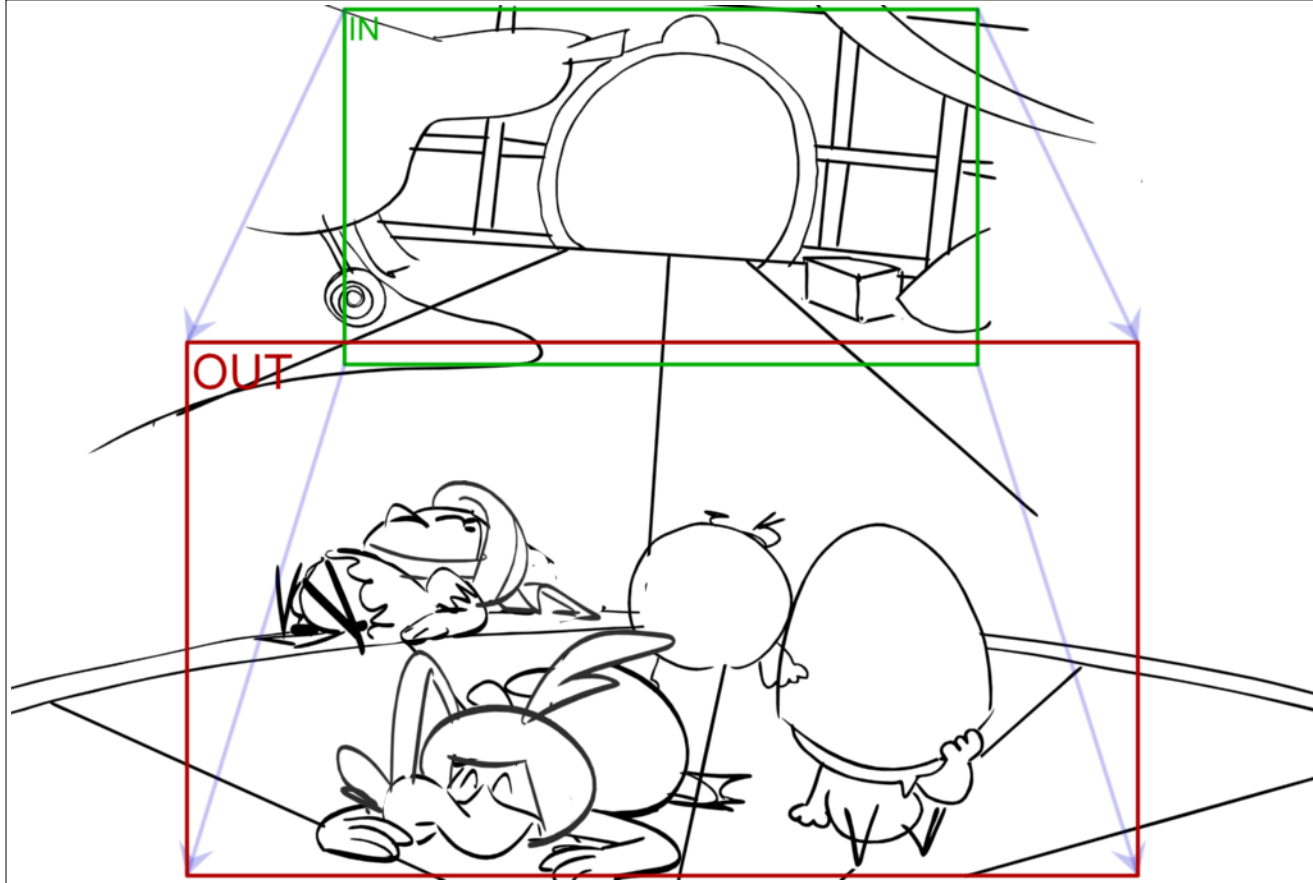

Action Notes

pan down on kids on floor

| Scene | Duration | Panel | Duration |
|-------|----------|-------|----------|
| 78 | 06:19 | 8 | 00:16 |

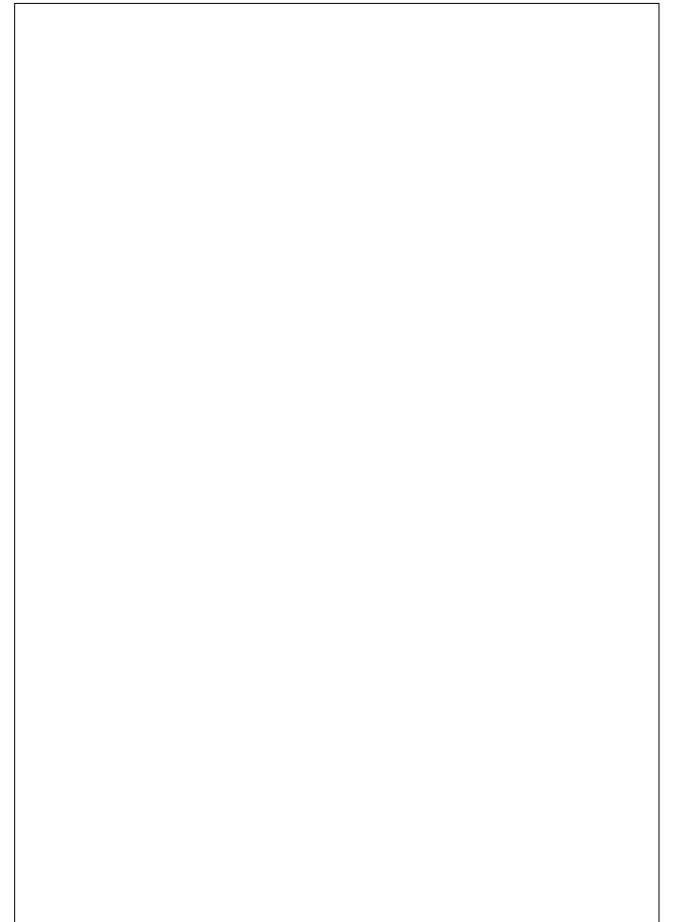
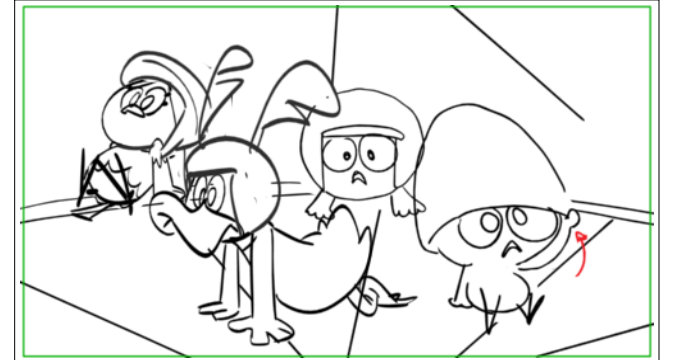

| Scene | Duration | Panel | Duration |
|-------|----------|-------|----------|
| 78 | 06:19 | 9 | 00:06 |

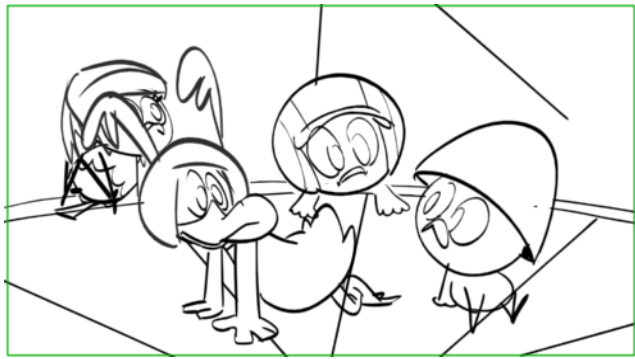

Action Notes

look at each other

| Scene | Duration | Panel | Duration |
|-------|----------|-------|----------|
| 78 | 06:19 | 10 | 02:02 |

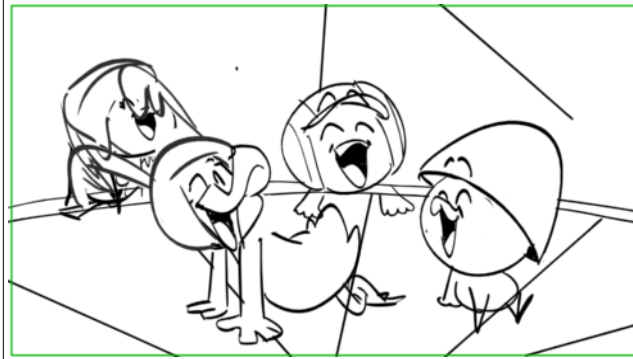

Action Notes

laugh

| Scene | Duration | Panel | Duration |
|-------|----------|-------|----------|
| 79 | 06:11 | 1 | 01:00 |

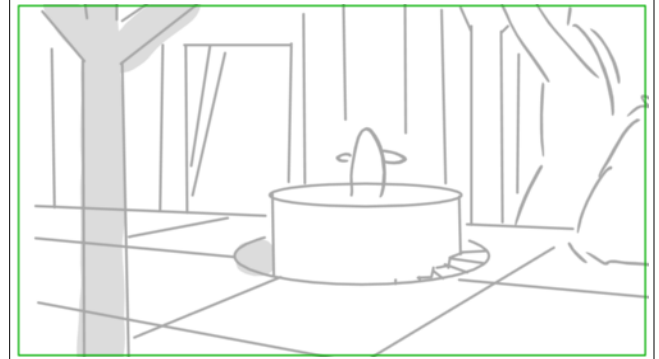

Action Notes

INT GRANGE jour

| Scene | Duration | Panel | Duration |
|-------|----------|-------|----------|
| 79 | 06:11 | 2 | 01:00 |

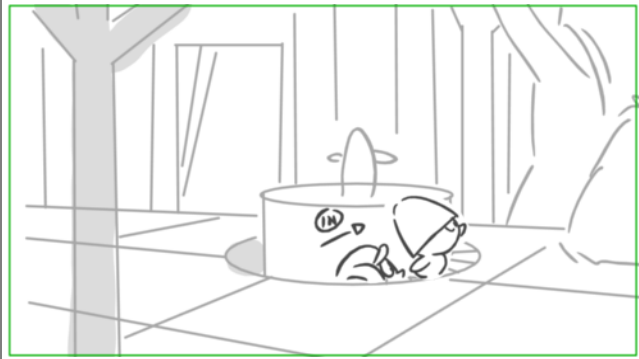

Dialogue
 63. CALIMERO (malicieux)
 Vite !

Action Notes
 les enfants sortent du passage secret

| Scene | Duration | Panel | Duration |
|-------|----------|-------|----------|
| 79 | 06:11 | 3 | 01:00 |

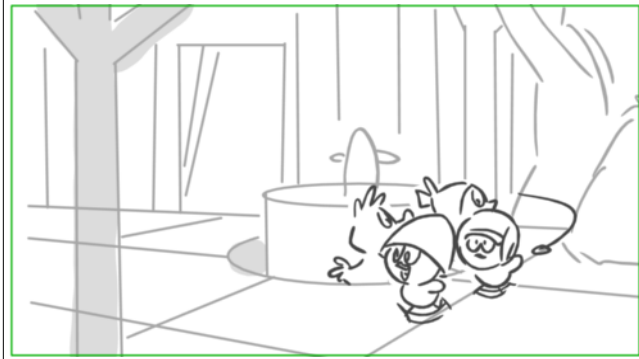

Dialogue
 63. CALIMERO (malicieux)
 au potager de maman !

| Scene | Duration | Panel | Duration |
|-------|----------|-------|----------|
| 79 | 06:11 | 4 | 01:00 |

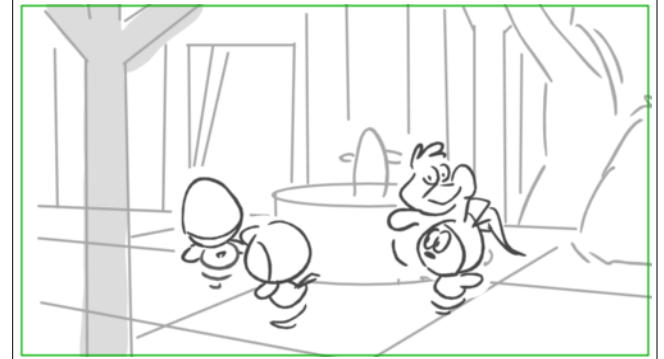



| Scene | Duration | Panel | Duration |
|-------|----------|-------|----------|
| 79 | 06:11 | 5 | 00:19 |

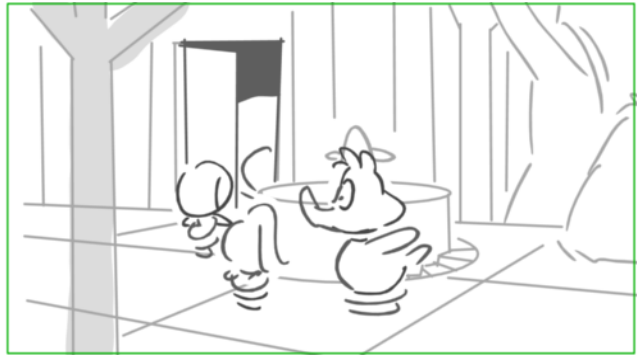

| Scene | Duration | Panel | Duration |
|-------|----------|-------|----------|
| 79 | 06:11 | 6 | 00:17 |

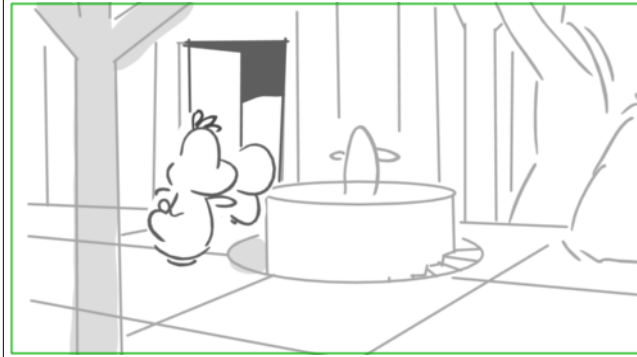

| Scene | Duration | Panel | Duration |
|-------|----------|-------|----------|
| 79 | 06:11 | 7 | 01:00 |

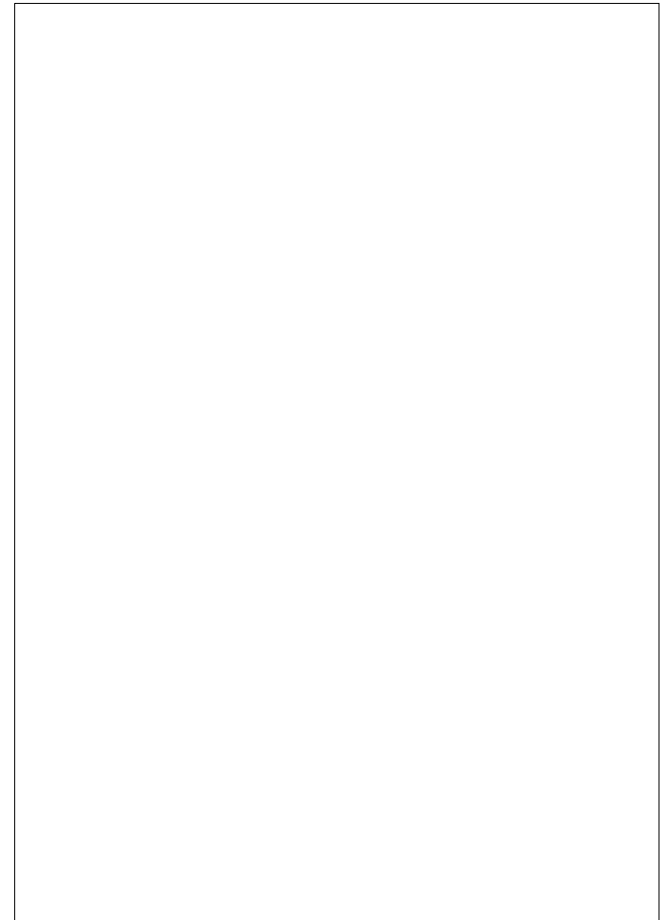
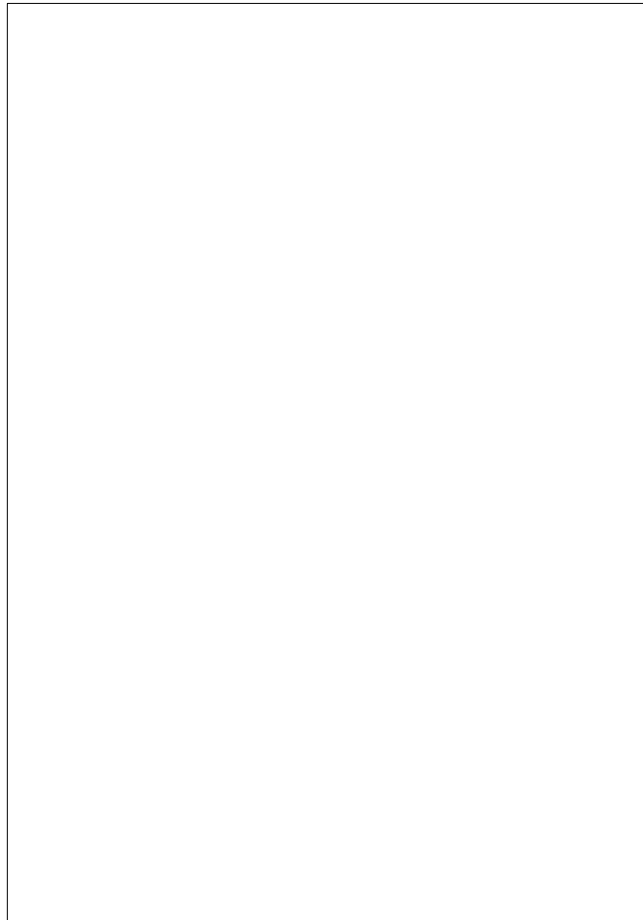
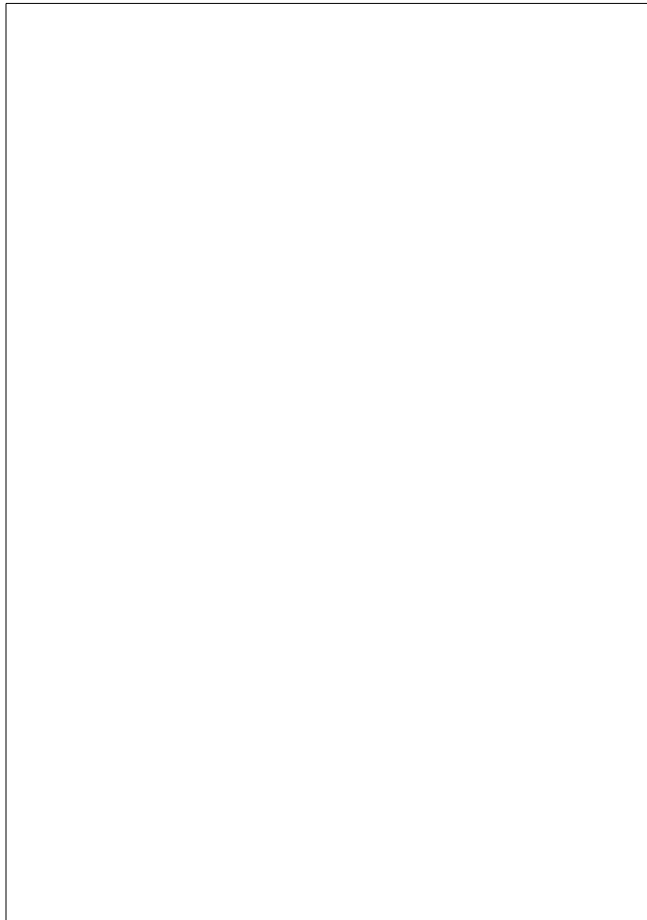
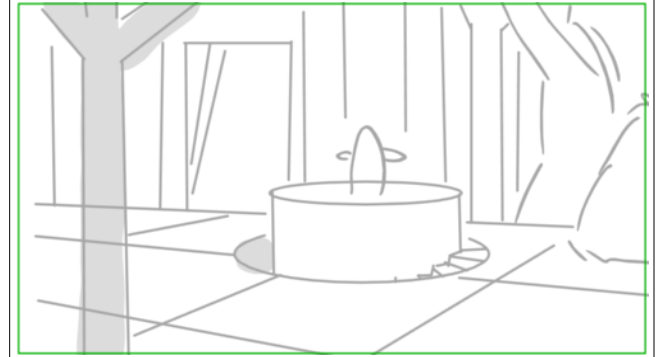

| Scene | Duration | Panel | Duration |
|-------|----------|-------|----------|
| 80 | 06:05 | 1 | 01:00 |

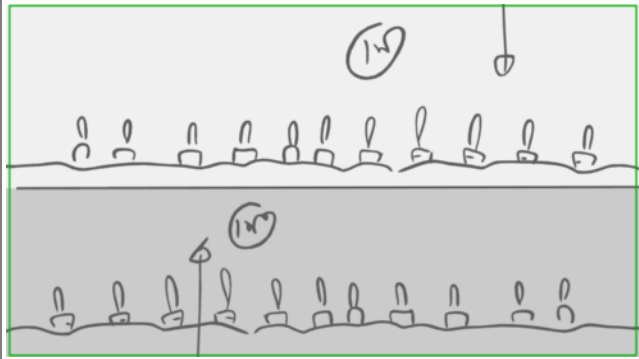

Action Notes

9. POTAGER CESIRA + ATELIER DE DO VINCI
+ AUTOUR DU MOULIN / EXT. + INT. JOUR ?
SEQUENCE CLIPESQUE SANS DIALOGUES

| Scene | Duration | Panel | Duration |
|-------|----------|-------|----------|
| 80 | 06:05 | 2 | 00:10 |

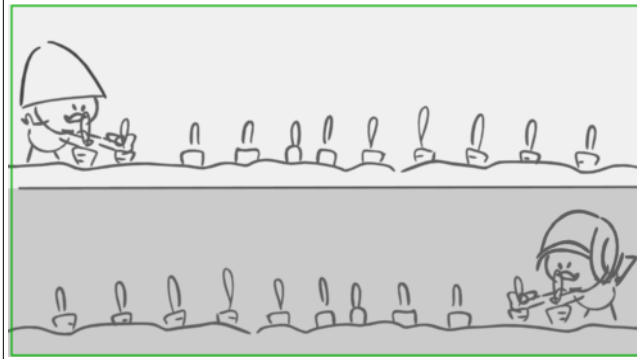

Action Notes

CAL et VAL ramassent des carottes dans
le verger

| Scene | Duration | Panel | Duration |
|-------|----------|-------|----------|
| 80 | 06:05 | 3 | 00:10 |

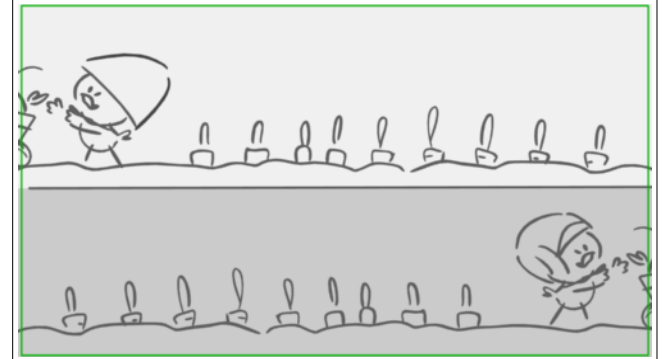



| Scene | Duration | Panel | Duration |
|-------|----------|-------|----------|
| 80 | 06:05 | 4 | 00:10 |

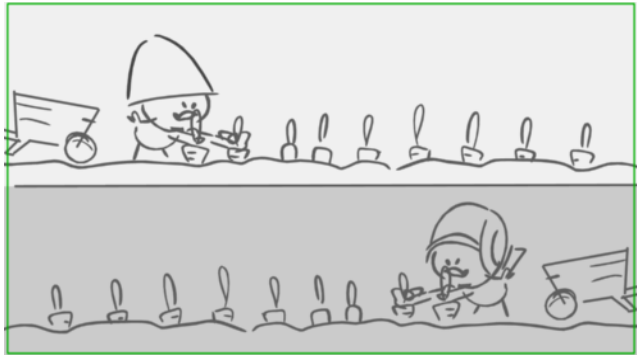

| Scene | Duration | Panel | Duration |
|-------|----------|-------|----------|
| 80 | 06:05 | 5 | 00:10 |

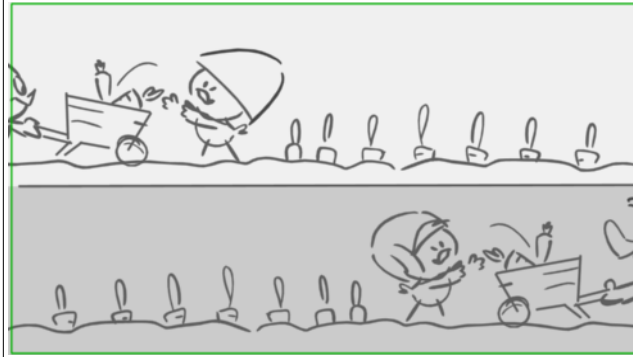

| Scene | Duration | Panel | Duration |
|-------|----------|-------|----------|
| 80 | 06:05 | 6 | 00:10 |

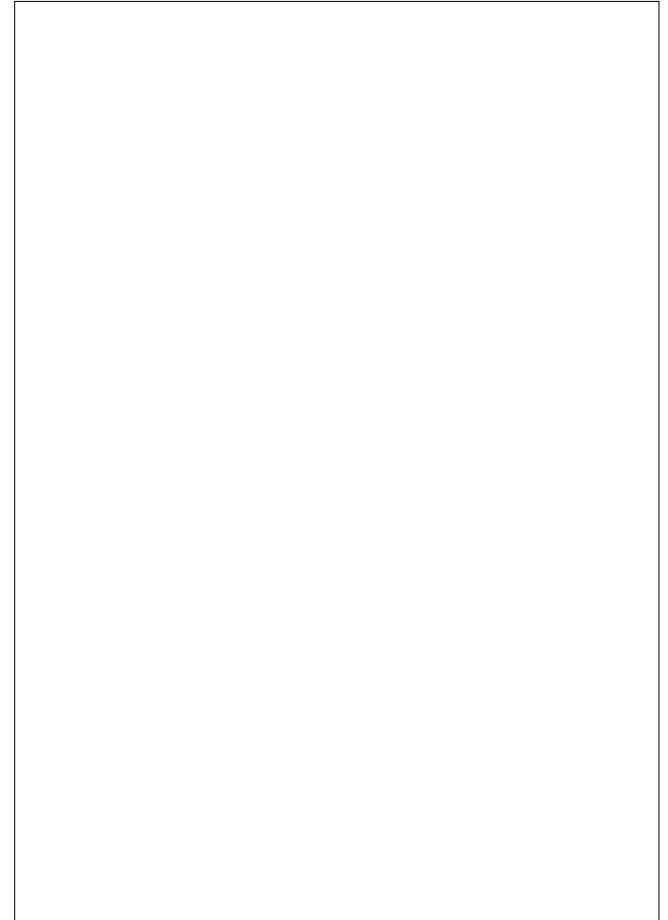
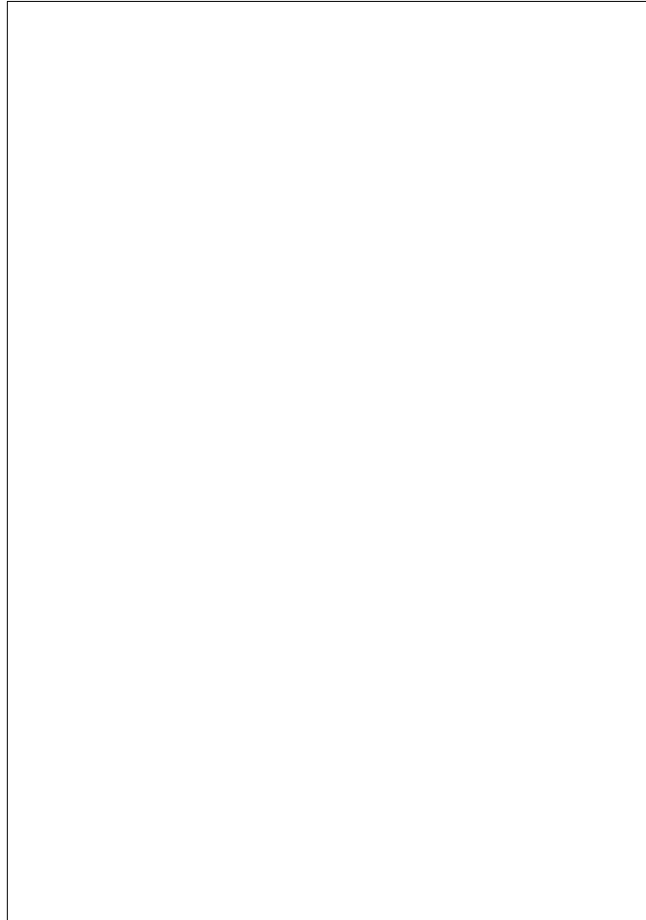
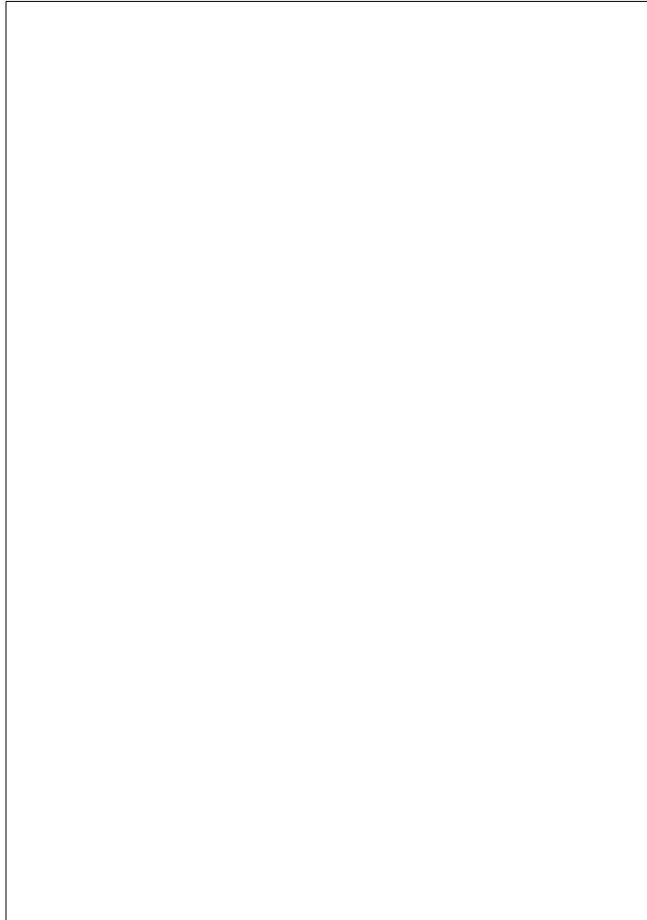
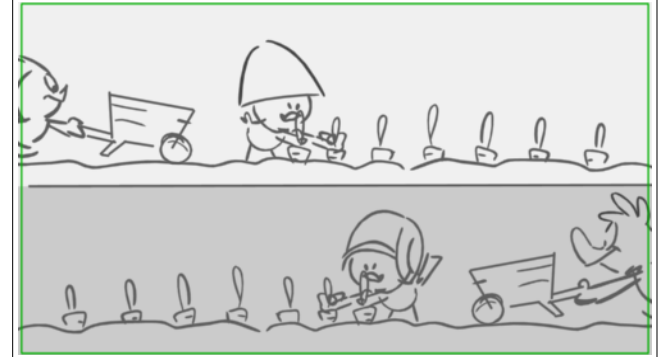

| Scene | Duration | Panel | Duration |
|-------|----------|-------|----------|
| 80 | 06:05 | 7 | 00:10 |

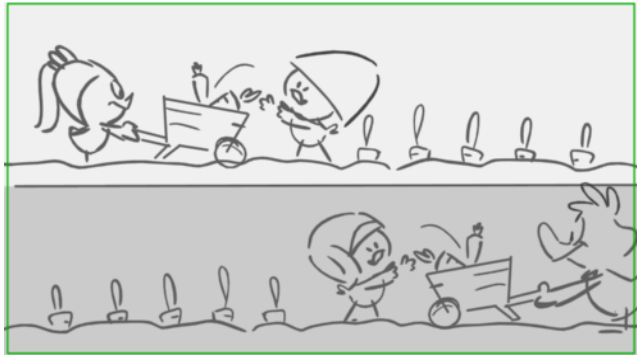

| Scene | Duration | Panel | Duration |
|-------|----------|-------|----------|
| 80 | 06:05 | 8 | 00:10 |



| Scene | Duration | Panel | Duration |
|-------|----------|-------|----------|
| 80 | 06:05 | 9 | 00:10 |

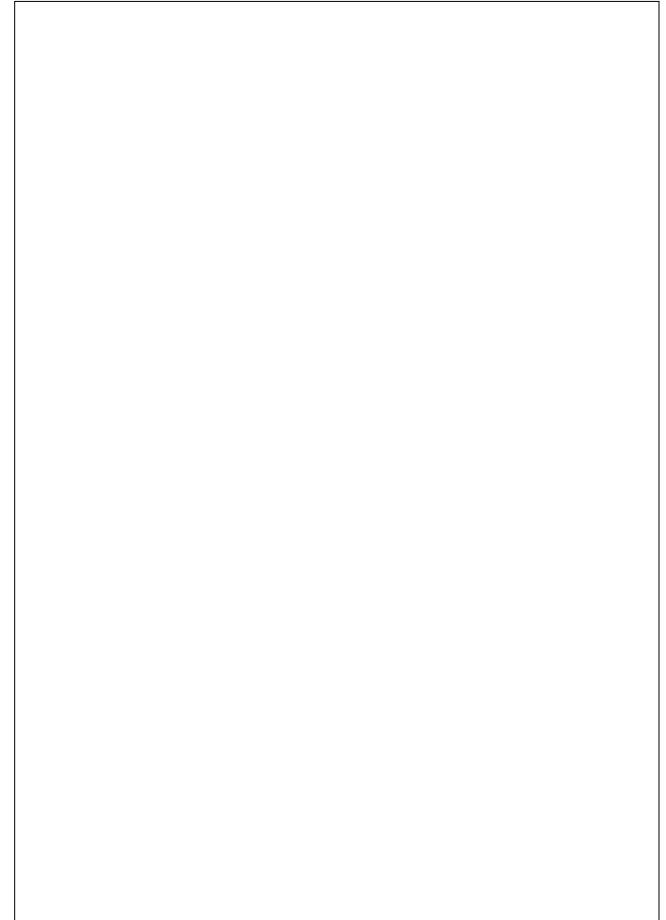
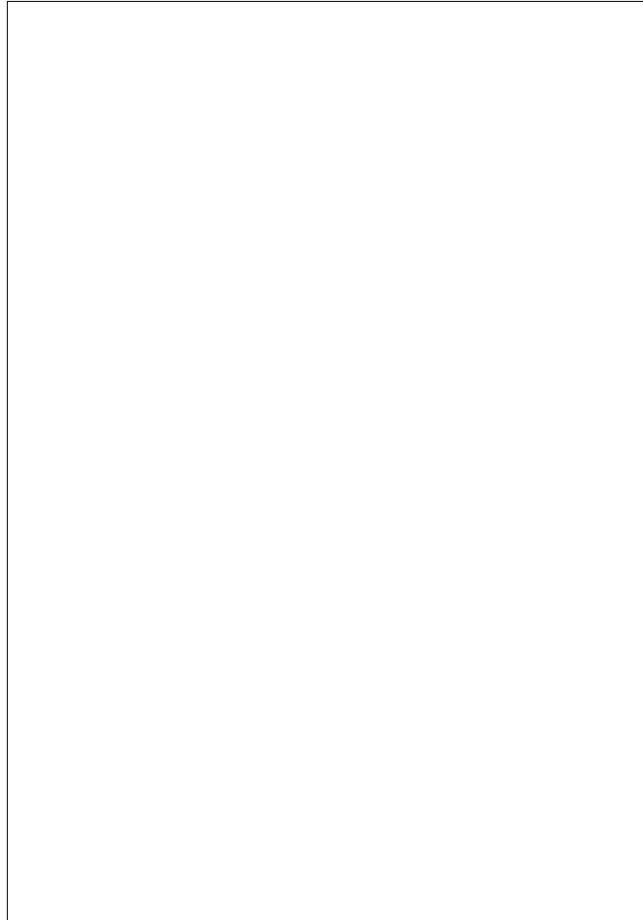
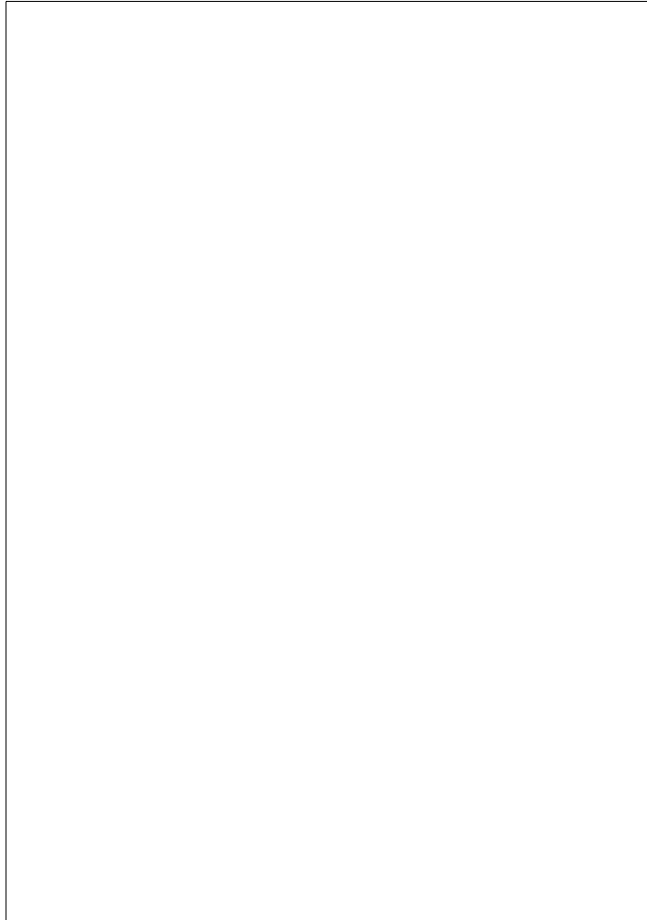
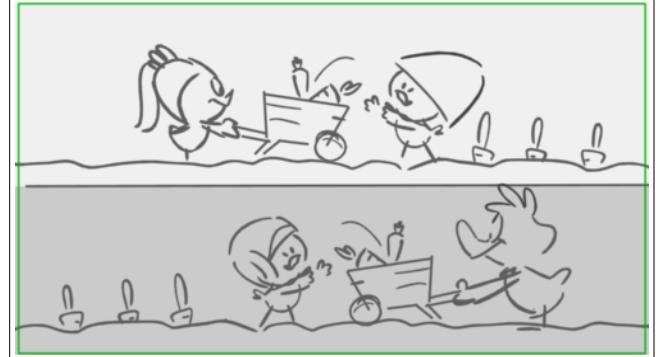



| Scene | Duration | Panel | Duration |
|-------|----------|-------|----------|
| 80 | 06:05 | 10 | 00:10 |



| Scene | Duration | Panel | Duration |
|-------|----------|-------|----------|
| 80 | 06:05 | 11 | 00:10 |

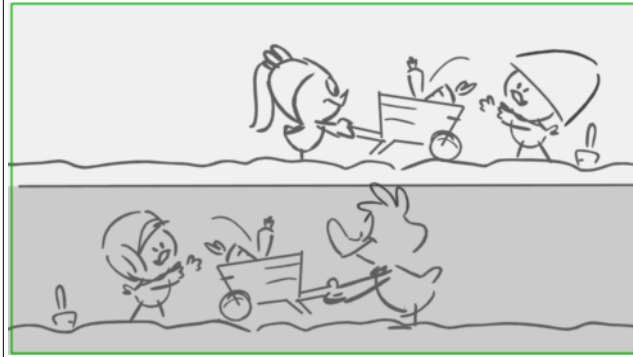

| Scene | Duration | Panel | Duration |
|-------|----------|-------|----------|
| 80 | 06:05 | 12 | 00:10 |

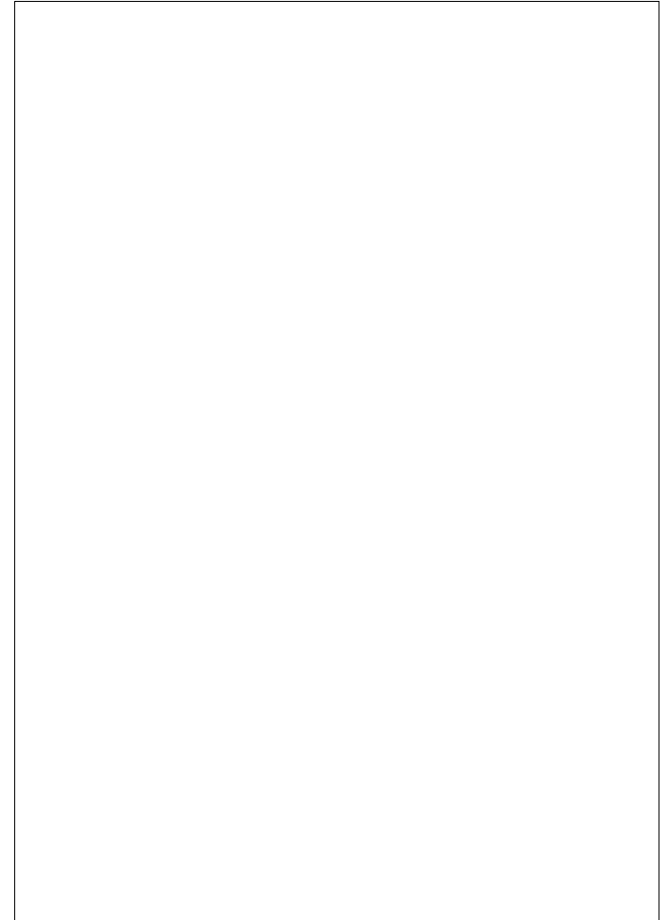
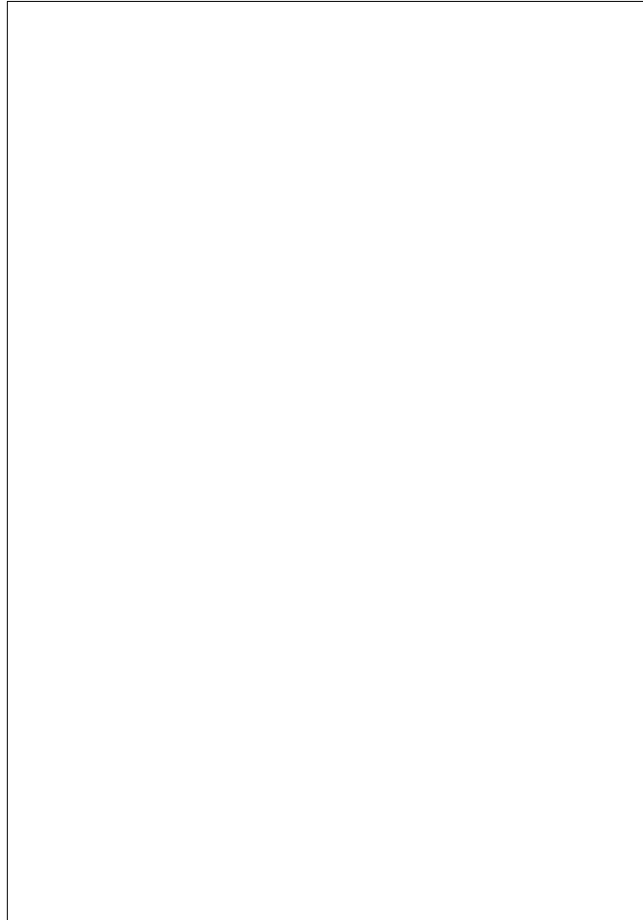
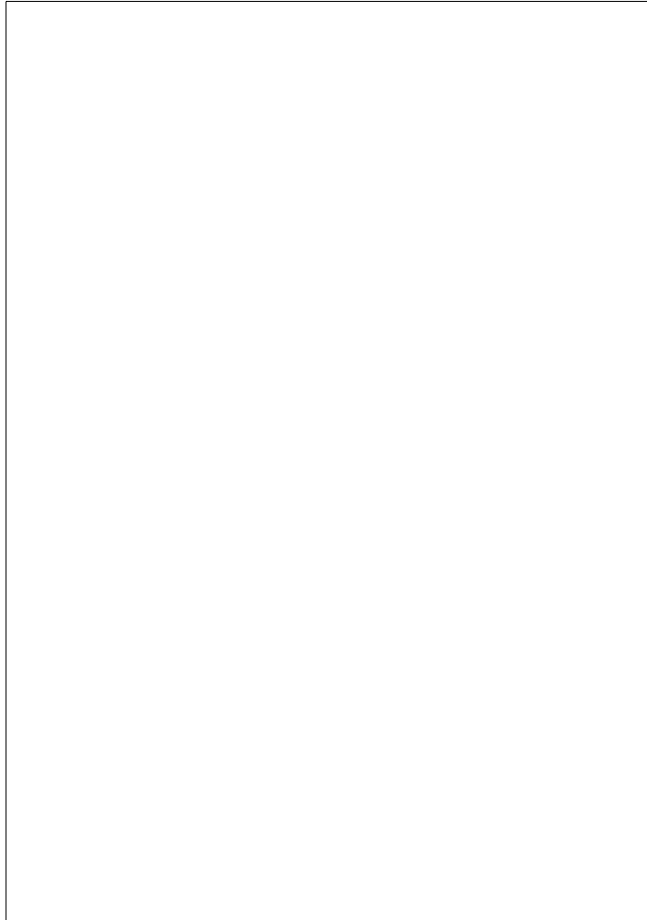
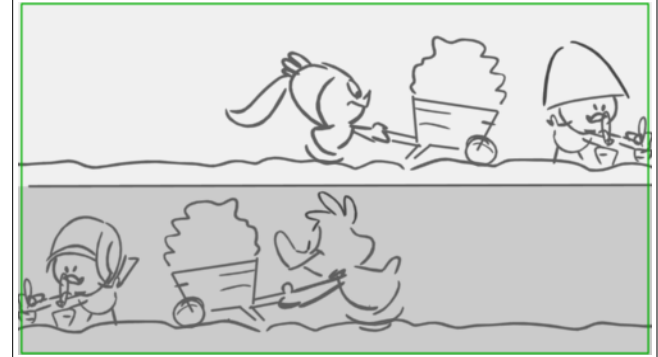

| Scene | Duration | Panel | Duration |
|-------|----------|-------|----------|
| 80 | 06:05 | 13 | 00:10 |

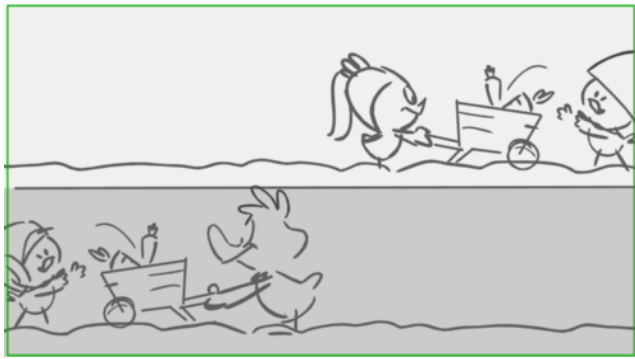

| Scene | Duration | Panel | Duration |
|-------|----------|-------|----------|
| 80 | 06:05 | 14 | 00:10 |

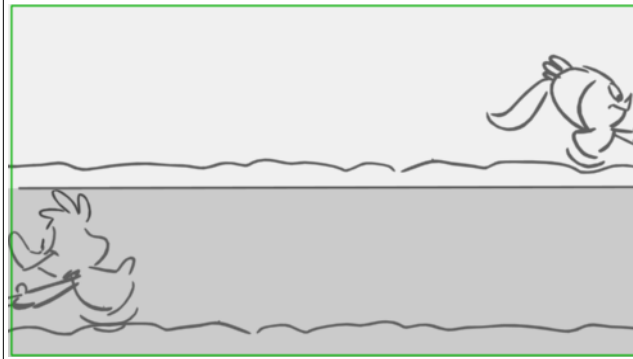

| Scene | Duration | Panel | Duration |
|-------|----------|-------|----------|
| 81 | 09:00 | 1 | 01:00 |

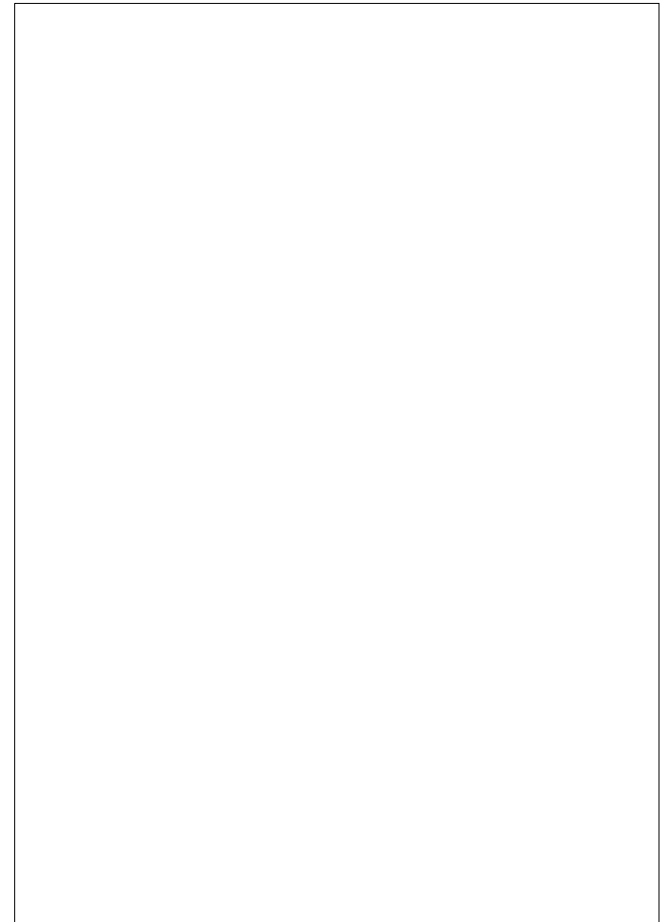
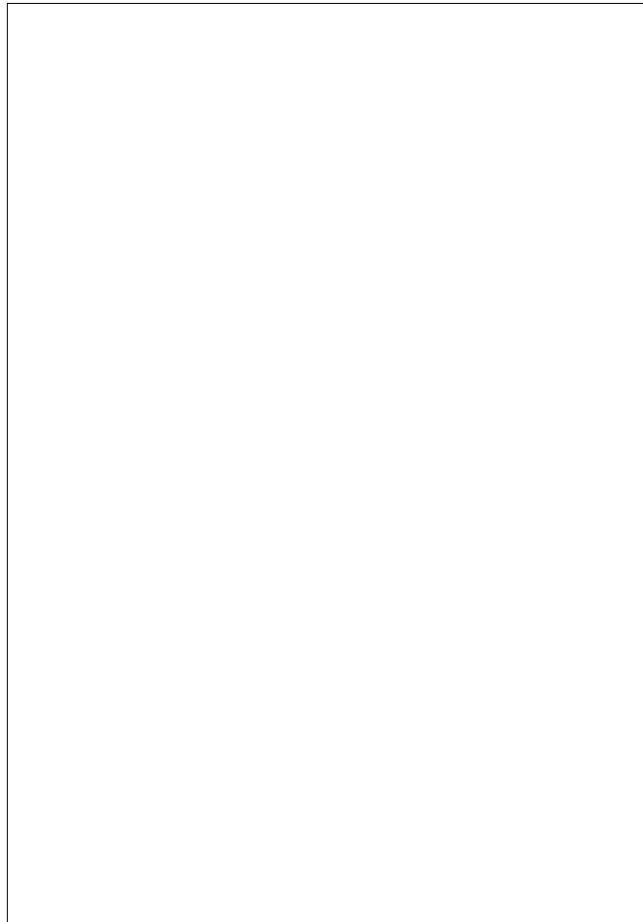
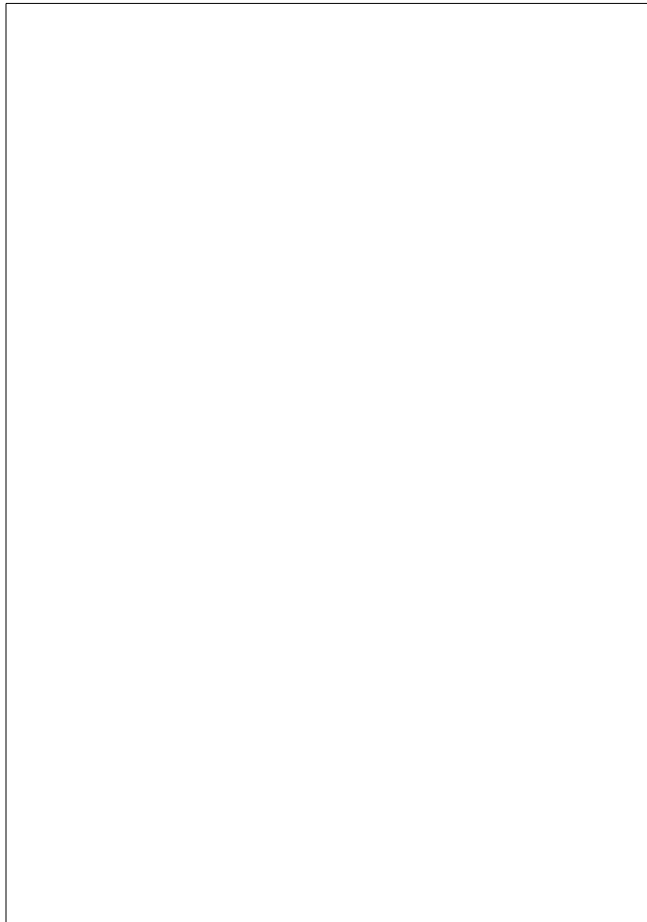
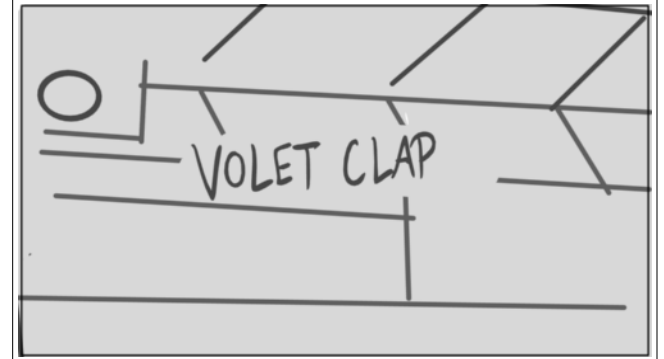

| Scene | Duration | Panel | Duration |
|-------|----------|-------|----------|
| 81 | 09:00 | 2 | 04:00 |

**Action Notes**

CAL dans l'oeuf volant avec plein de cannes a peche au bout desquelles des carottes
Val sur robot aspirateur suit en filmant les carottes



| Scene | Duration | Panel | Duration |
|-------|----------|-------|----------|
| 81 | 09:00 | 2 | 04:00 |

| Scene | Duration | Panel | Duration |
|-------|----------|-------|----------|
| 81 | 09:00 | 3 | 04:00 |

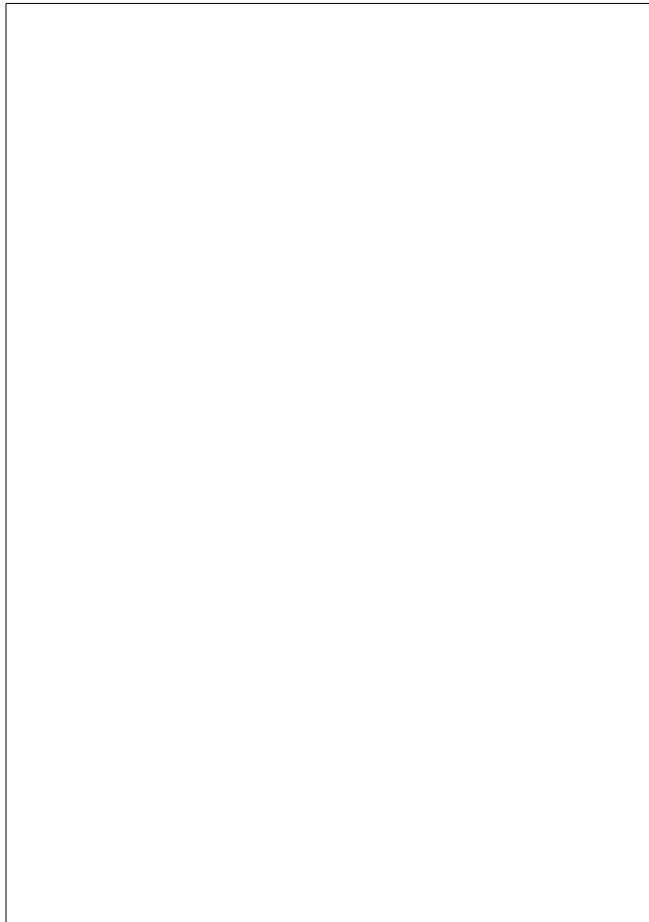
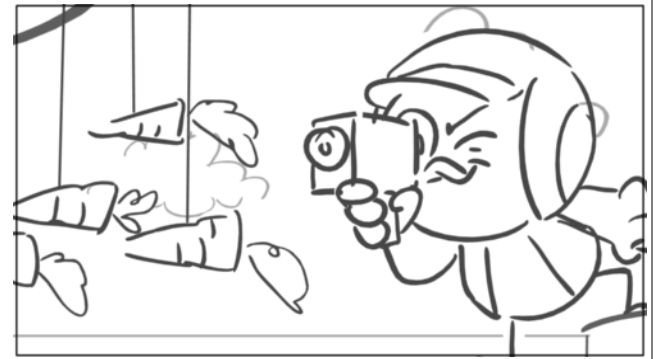
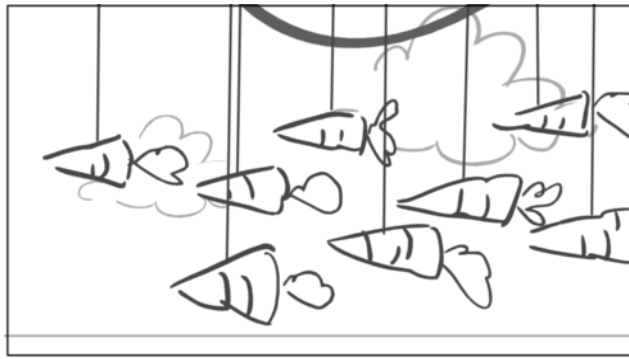



| Scene | Duration | Panel | Duration |
|-------|----------|-------|----------|
| 81 | 09:00 | 3 | 04:00 |



| Scene | Duration | Panel | Duration |
|-------|----------|-------|----------|
| 82 | 04:00 | 1 | 01:00 |

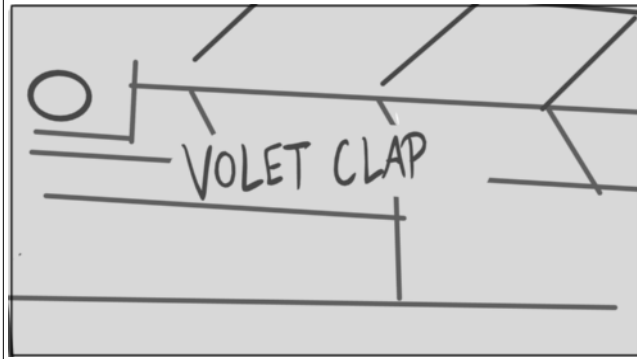

| Scene | Duration | Panel | Duration |
|-------|----------|-------|----------|
| 82 | 04:00 | 2 | 01:00 |

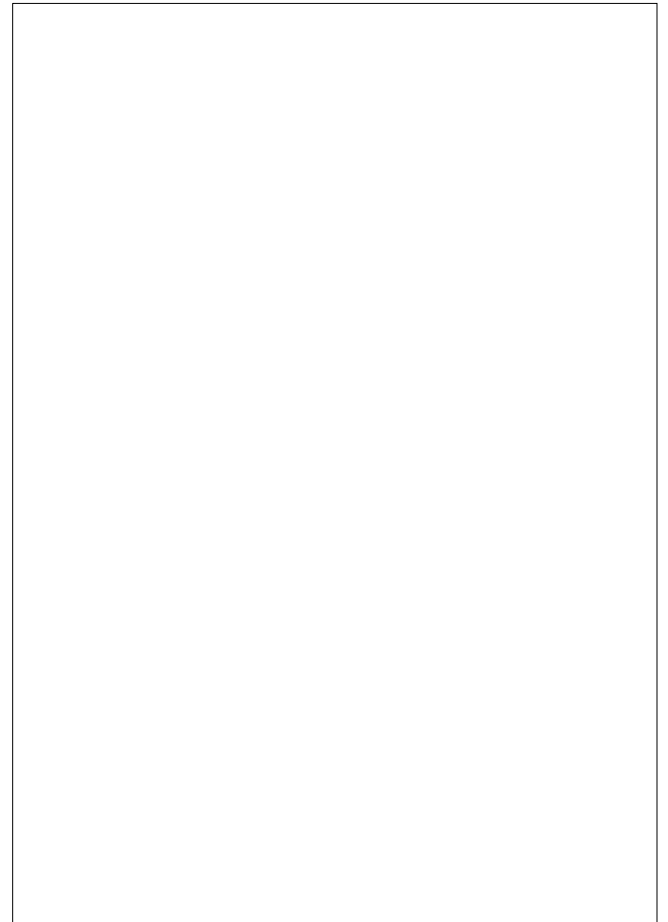
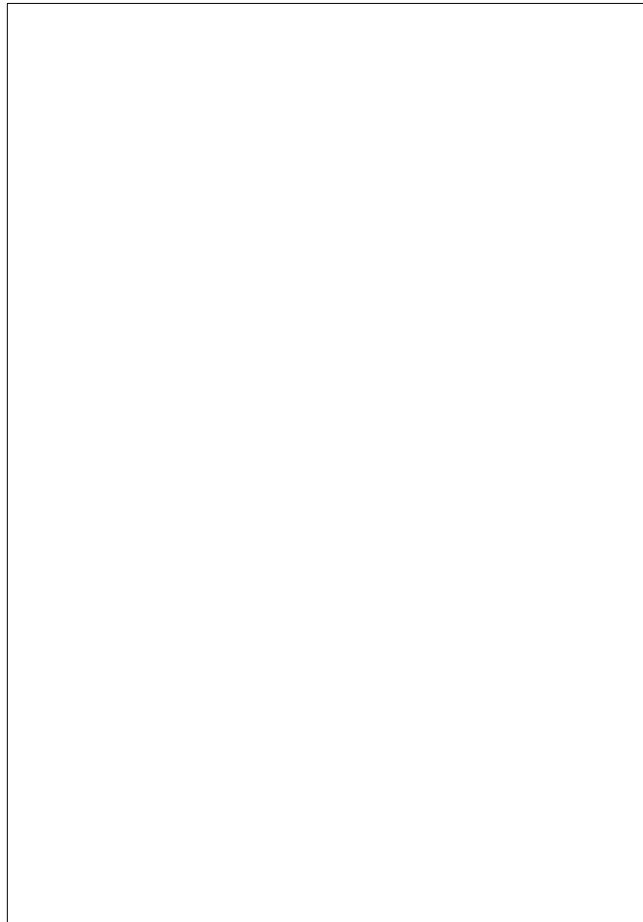
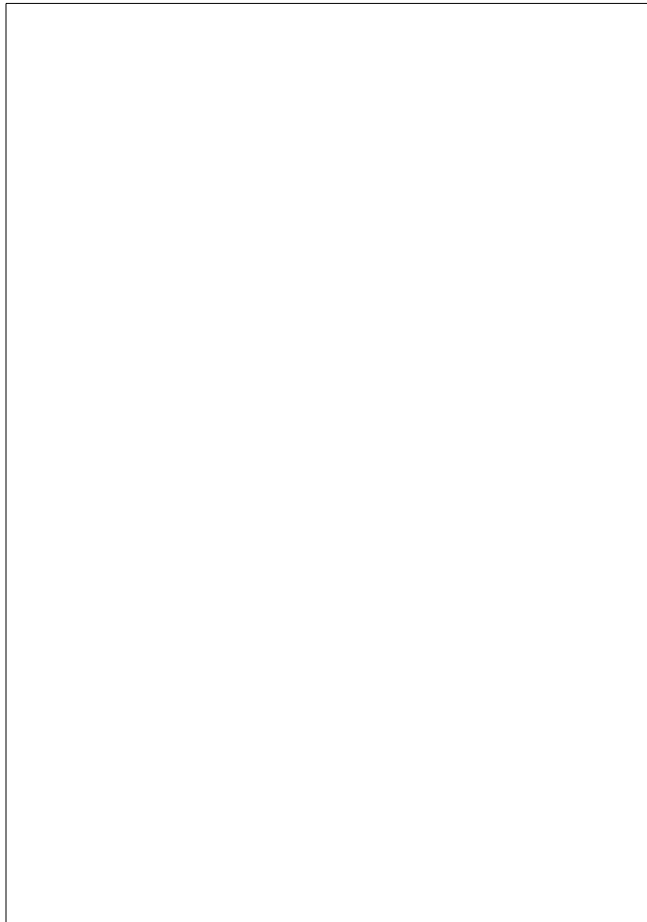
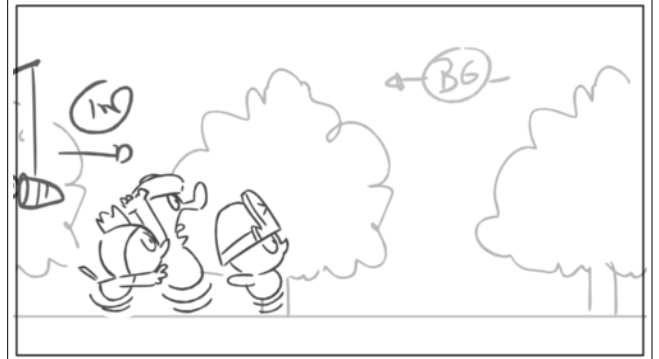



| Scene | Duration | Panel | Duration |
|-------|----------|-------|----------|
| 82 | 04:00 | 3 | 01:00 |

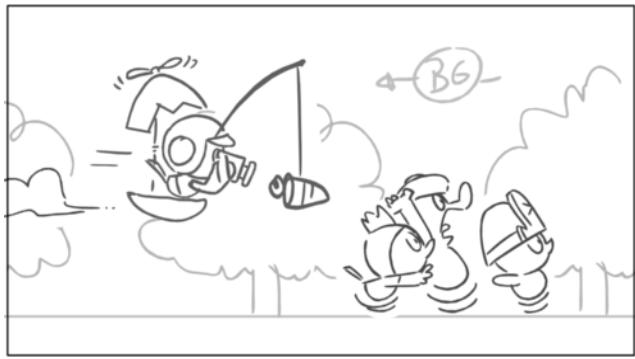

| Scene | Duration | Panel | Duration |
|-------|----------|-------|----------|
| 82 | 04:00 | 4 | 01:00 |

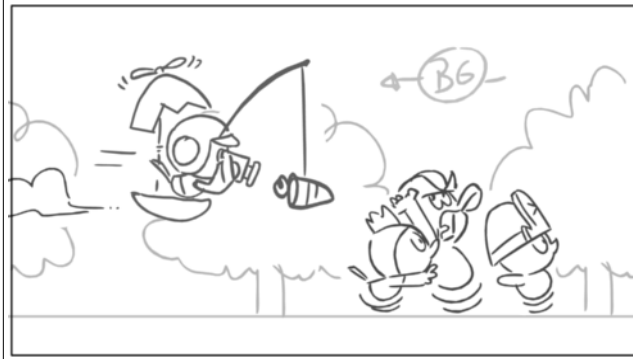

| Scene | Duration | Panel | Duration |
|-------|----------|-------|----------|
| 83 | 02:00 | 1 | 01:00 |

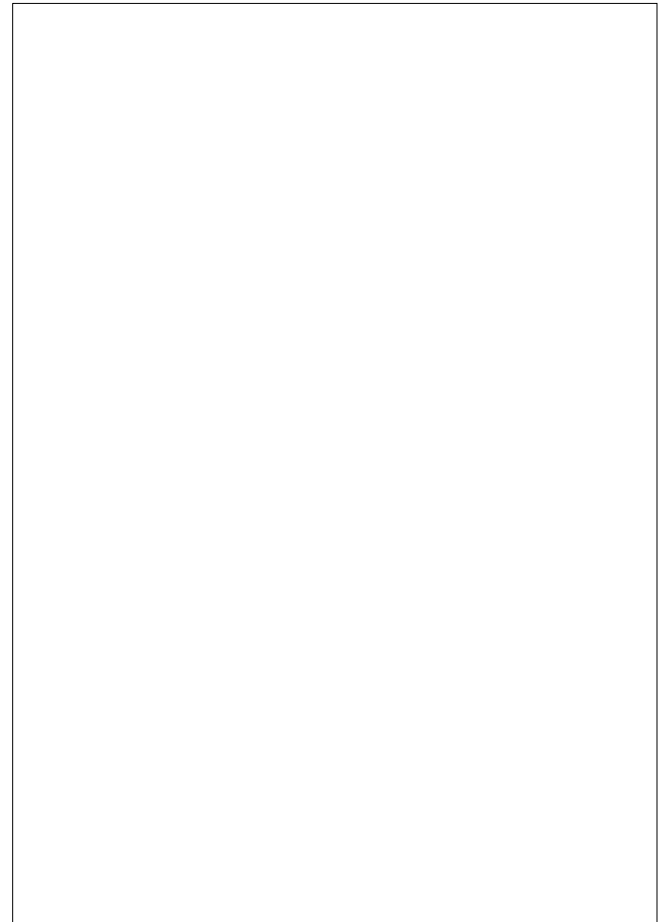
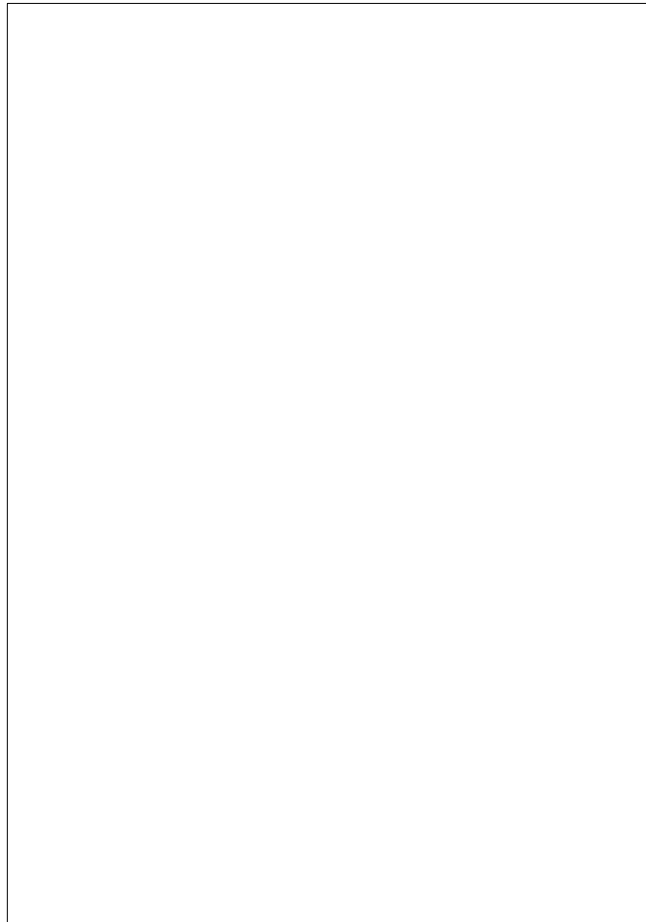
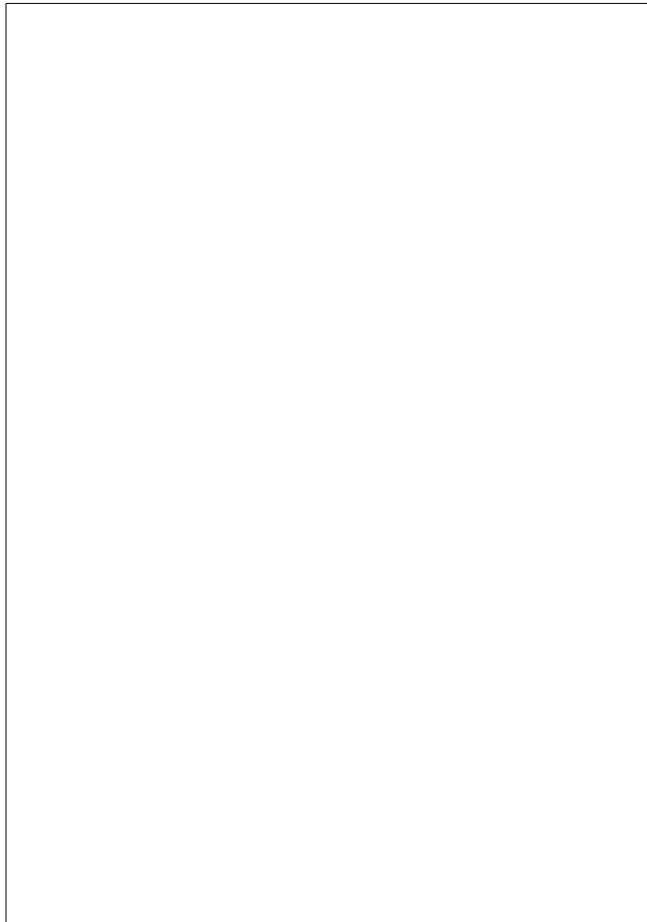
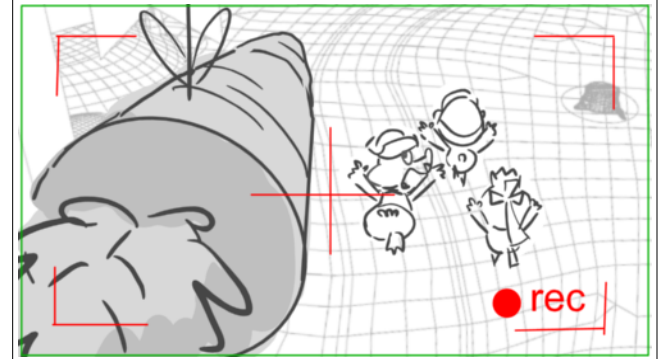

| Scene | Duration | Panel | Duration |
|-------|----------|-------|----------|
| 83 | 02:00 | 2 | 00:10 |

| Scene | Duration | Panel | Duration |
|-------|----------|-------|----------|
| 83 | 02:00 | 3 | 00:15 |

| Scene | Duration | Panel | Duration |
|-------|----------|-------|----------|
| 84 | 03:21 | 1 | 01:00 |

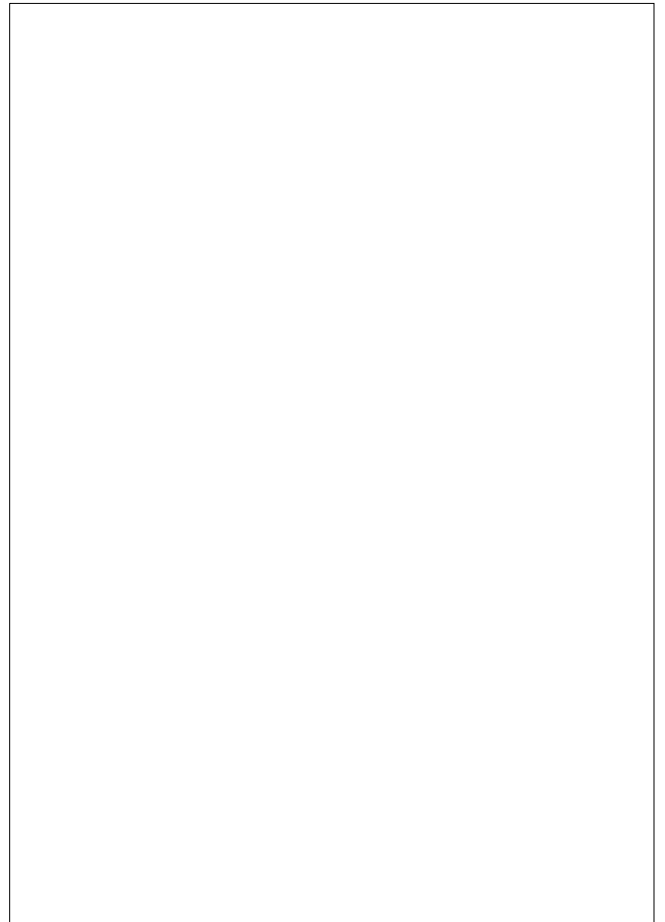
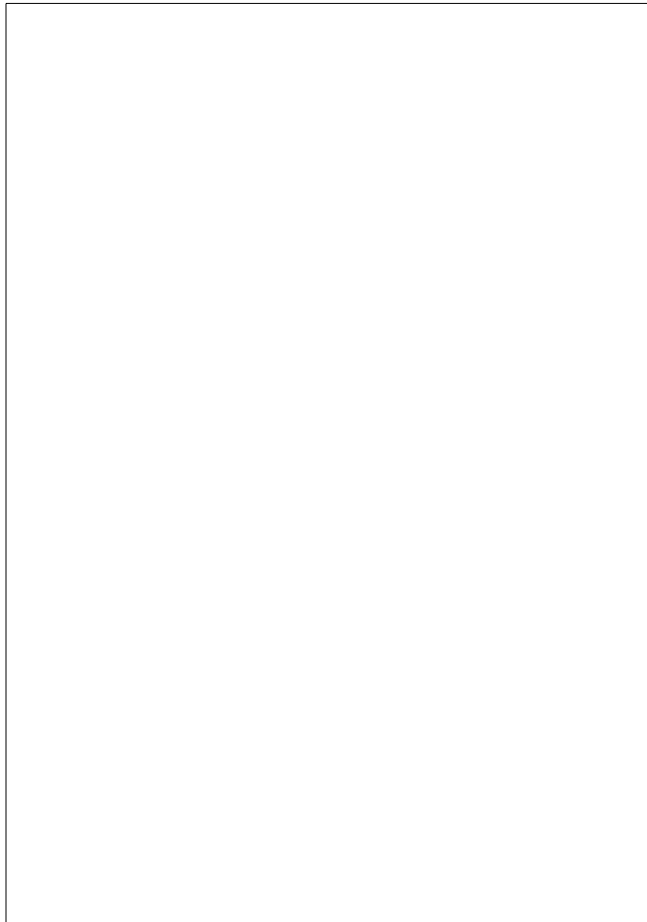
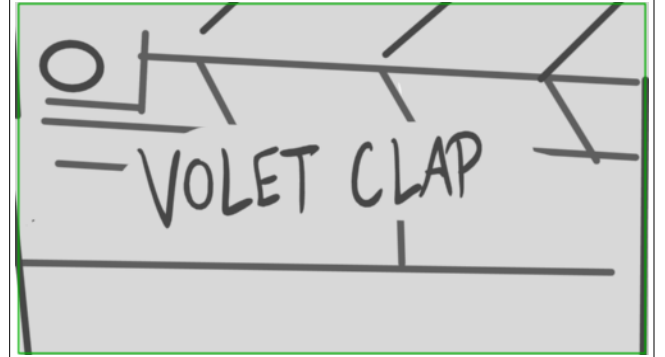
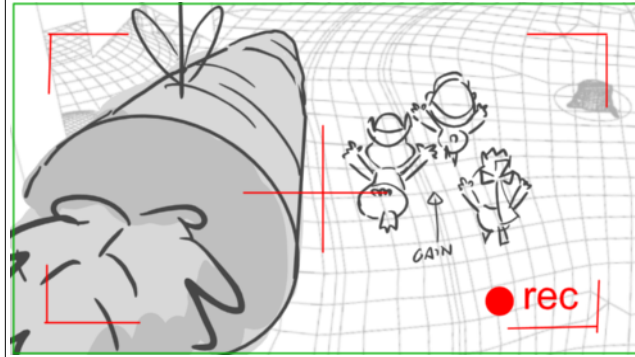
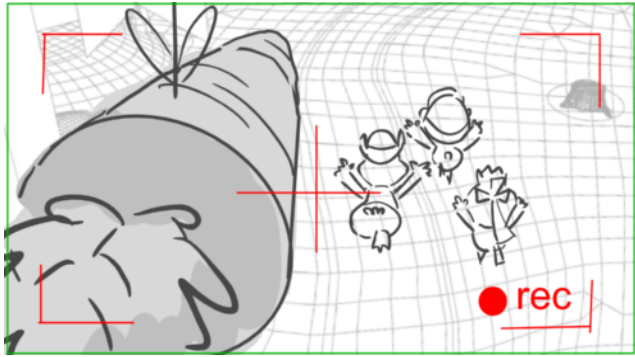

| Scene | Duration | Panel | Duration |
|-------|----------|-------|----------|
| 84 | 03:21 | 2 | 01:21 |

| Scene | Duration | Panel | Duration |
|-------|----------|-------|----------|
| 84 | 03:21 | 3 | 01:00 |

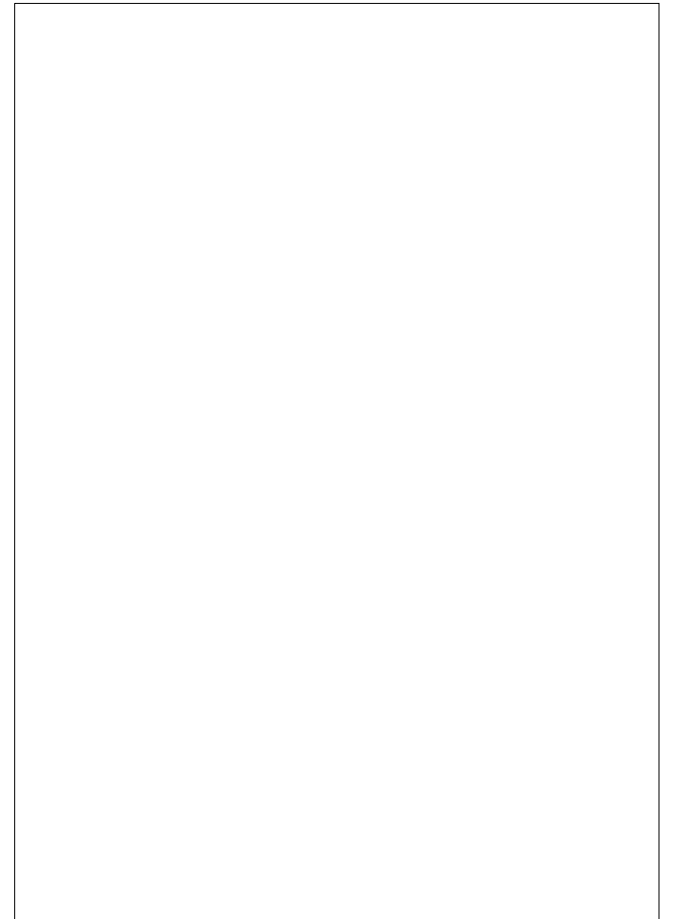
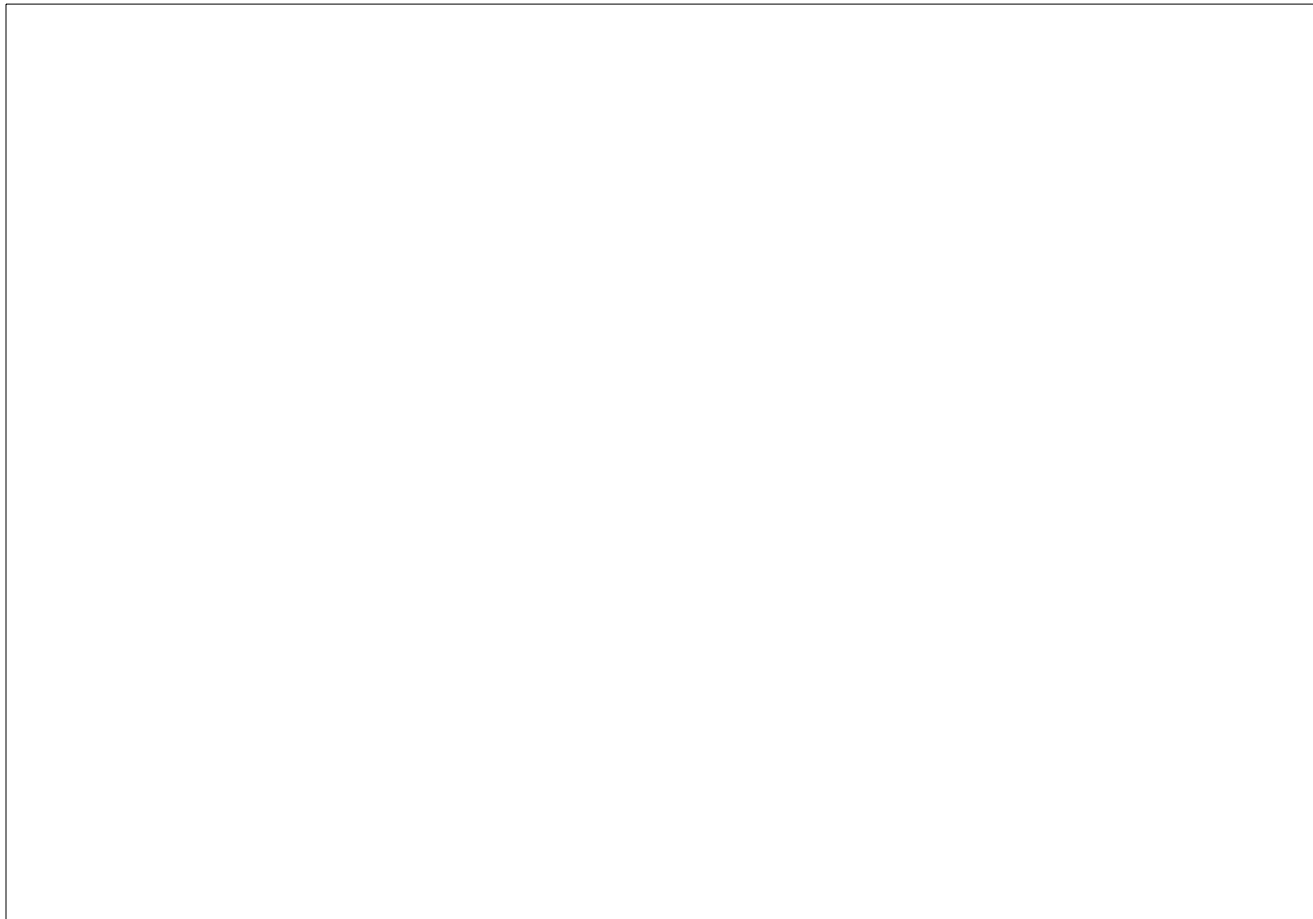
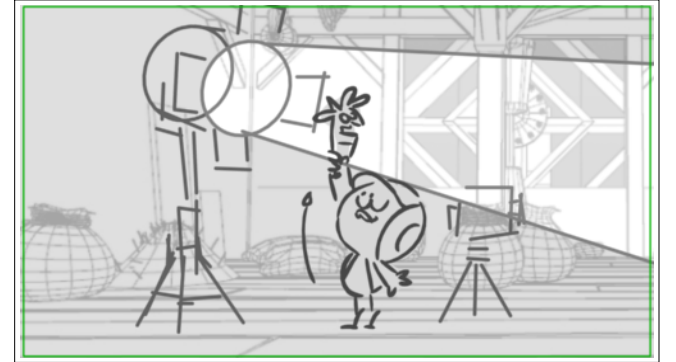
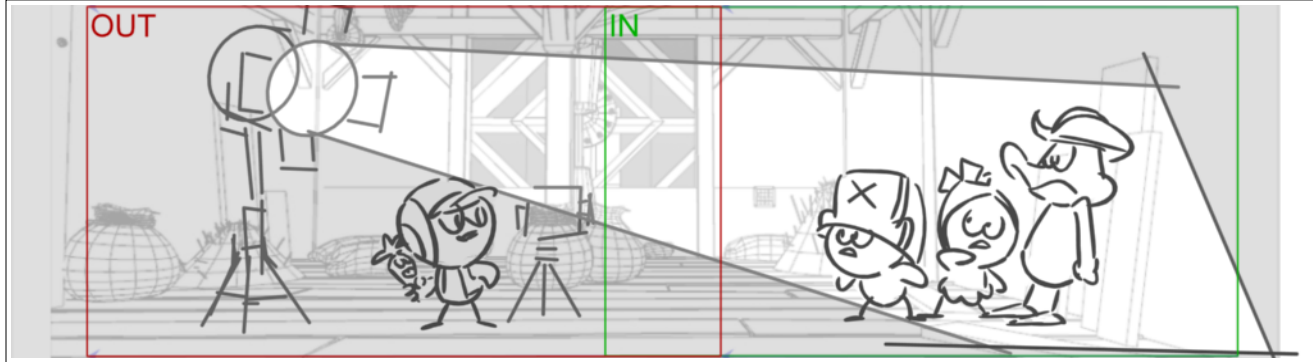

| Scene | Duration | Panel | Duration |
|-------|----------|-------|----------|
| 85 | 01:14 | 1 | 00:13 |

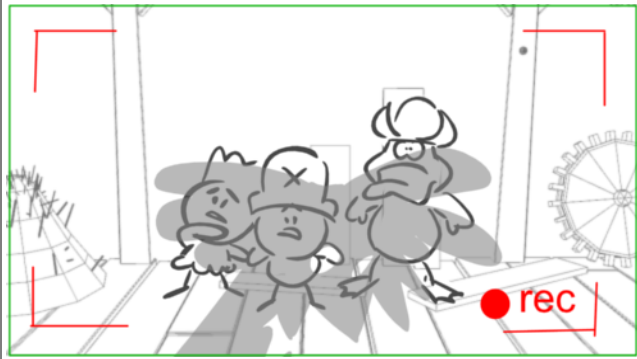

| Scene | Duration | Panel | Duration |
|-------|----------|-------|----------|
| 85 | 01:14 | 2 | 01:01 |

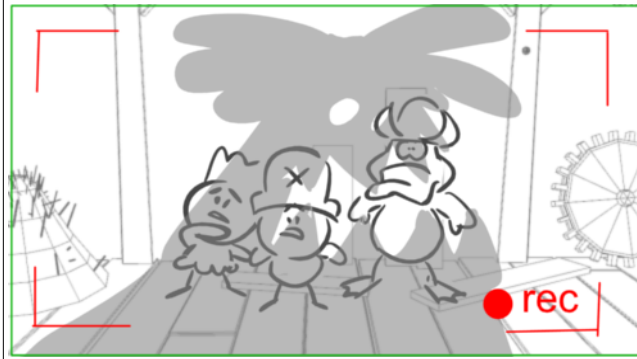

| Scene | Duration | Panel | Duration |
|-------|----------|-------|----------|
| 86 | 03:14 | 1 | 01:00 |

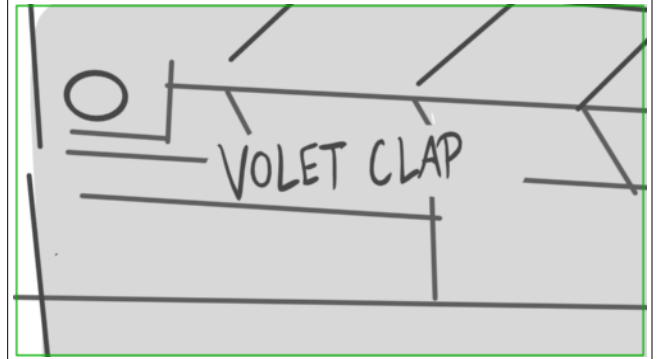

Action Notes

ombre portée de la carotte



| Scene | Duration | Panel | Duration |
|-------|----------|-------|----------|
| 86 | 03:14 | 2 | 00:19 |

| Scene | Duration | Panel | Duration |
|-------|----------|-------|----------|
| 86 | 03:14 | 3 | 00:20 |

NO PANEL

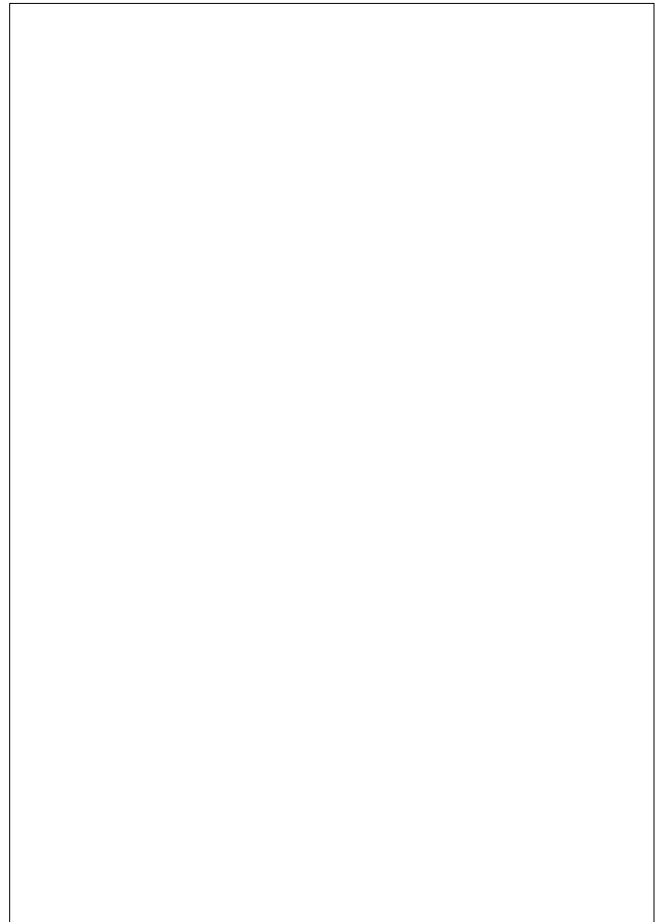
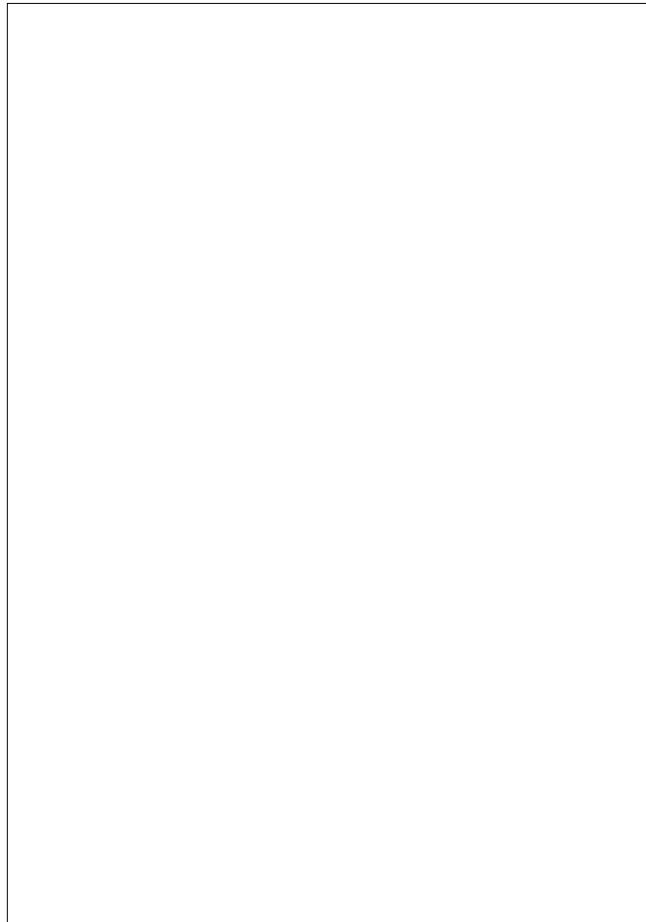
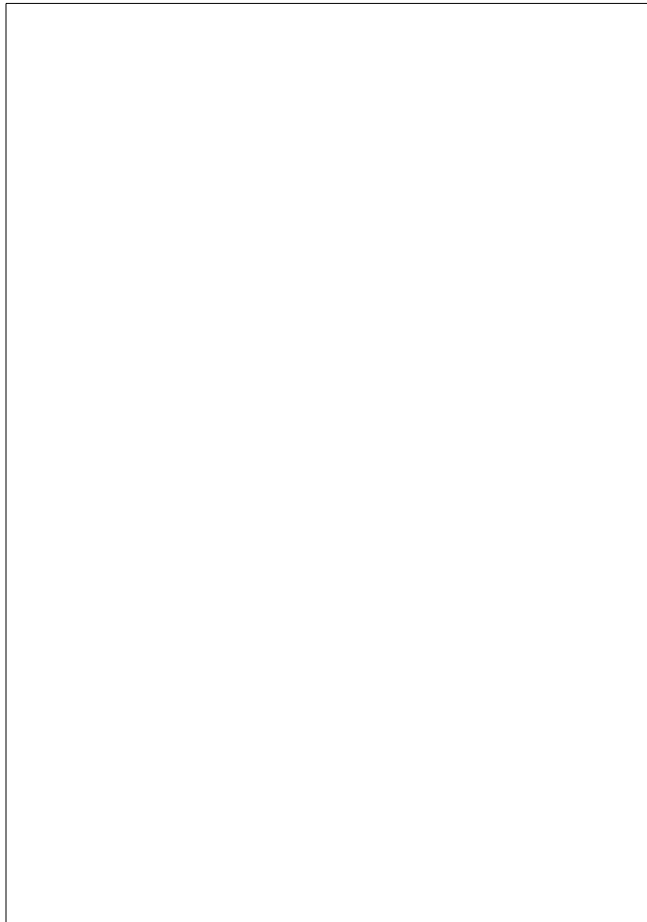
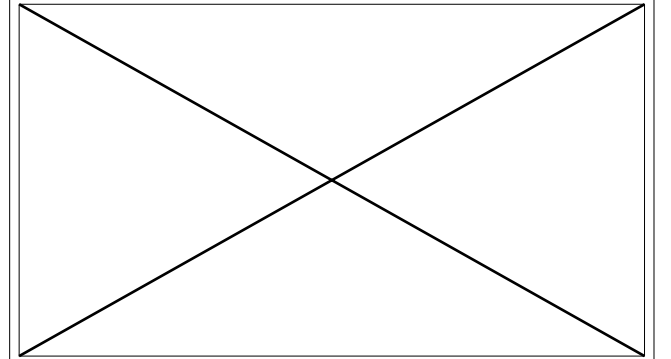

| Scene | Duration | Panel | Duration |
|-------|----------|-------|----------|
| 86 | 03:14 | 4 | 01:00 |

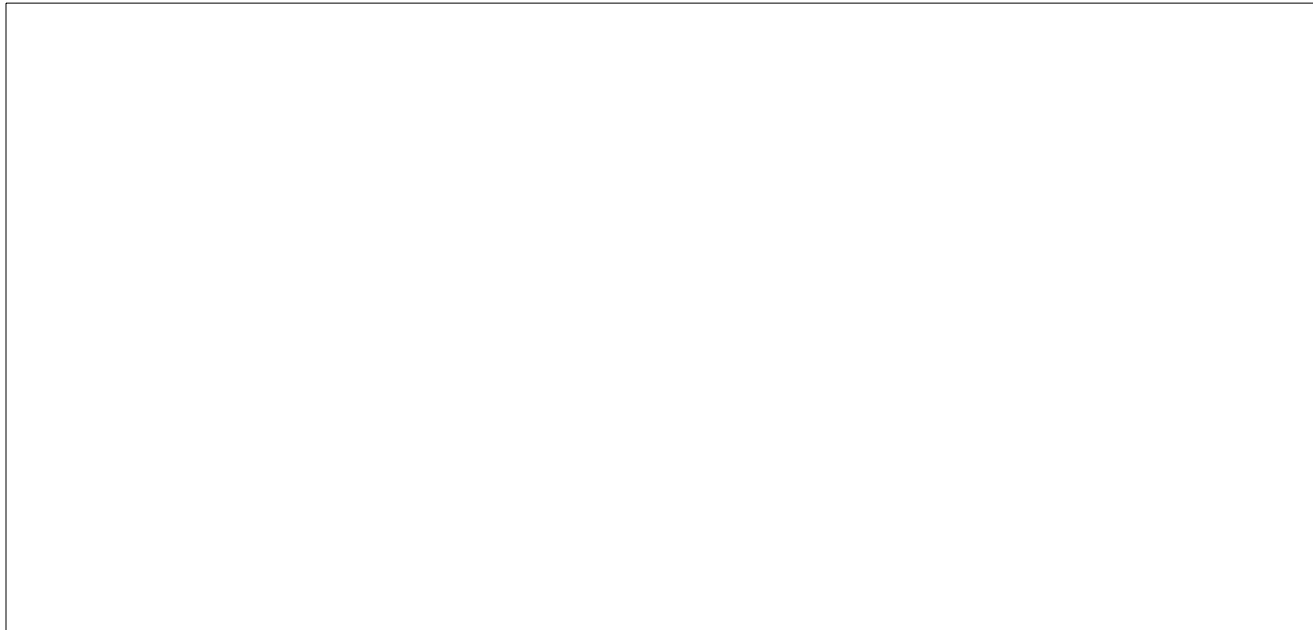
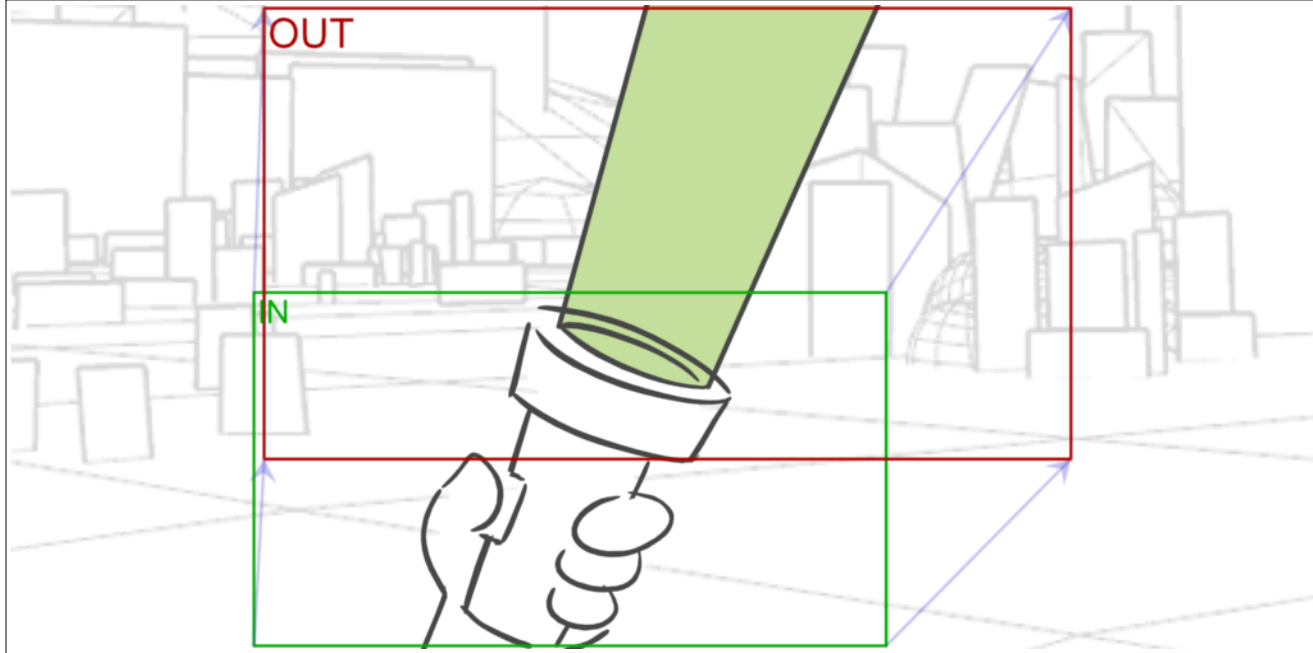

| Scene | Duration | Panel | Duration |
|-------|----------|-------|----------|
| 87 | 06:13 | 1 | 00:11 |

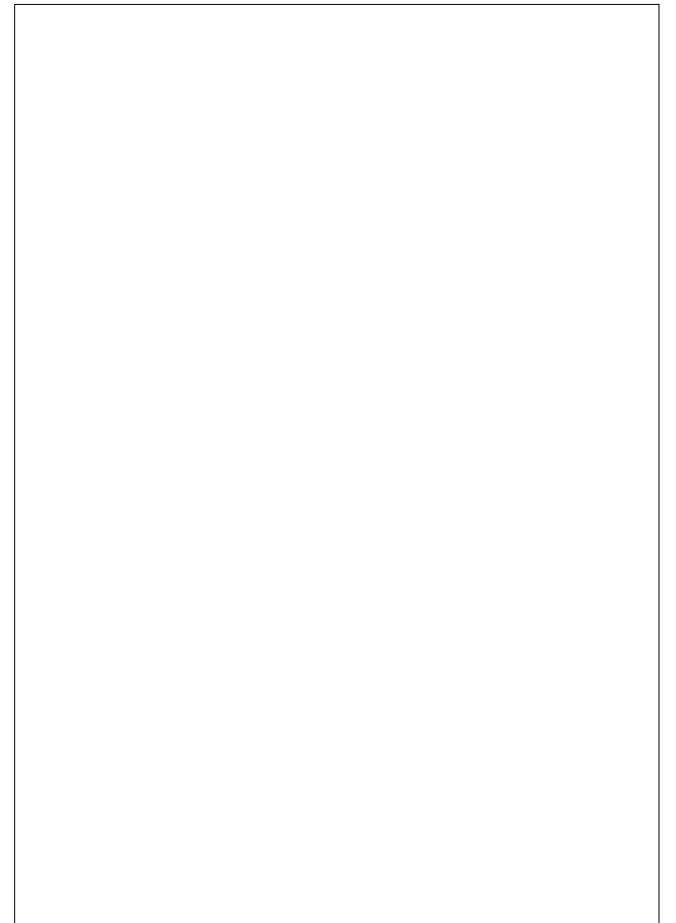

| Scene | Duration | Panel | Duration |
|-------|----------|-------|----------|
| 87 | 06:13 | 2 | 01:00 |



| Scene | Duration | Panel | Duration |
|-------|----------|-------|----------|
| 87 | 06:13 | 3 | 01:00 |

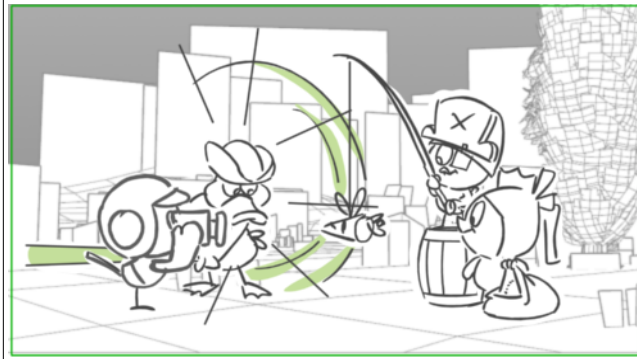

Action Notes

Pierrot passe son laser sur la carotte

| Scene | Duration | Panel | Duration |
|-------|----------|-------|----------|
| 87 | 06:13 | 4 | 00:10 |

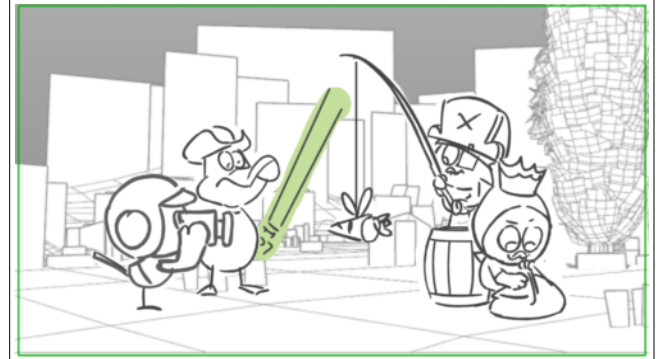

| Scene | Duration | Panel | Duration |
|-------|----------|-------|----------|
| 87 | 06:13 | 5 | 00:19 |

| Scene | Duration | Panel | Duration |
|-------|----------|-------|----------|
| 87 | 06:13 | 6 | 00:20 |

| Scene | Duration | Panel | Duration |
|-------|----------|-------|----------|
| 87 | 06:13 | 7 | 00:18 |



Action Notes

PRISC envoie une poignée de farine

| Scene | Duration | Panel | Duration |
|-------|----------|-------|----------|
| 87 | 06:13 | 8 | 00:18 |

| Scene | Duration | Panel | Duration |
|-------|----------|-------|----------|
| 87 | 06:13 | 9 | 00:17 |

| Scene | Duration | Panel | Duration |
|-------|----------|-------|----------|
| 88 | 01:00 | 1 | 01:00 |

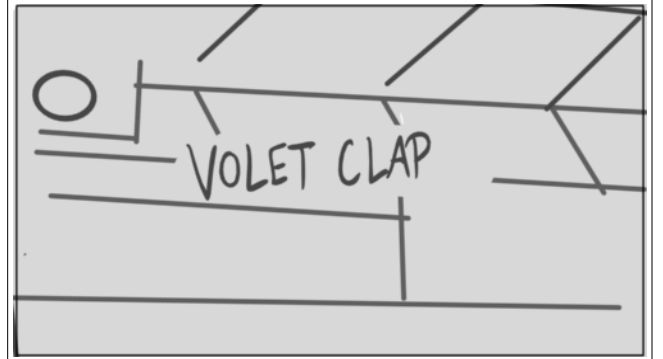
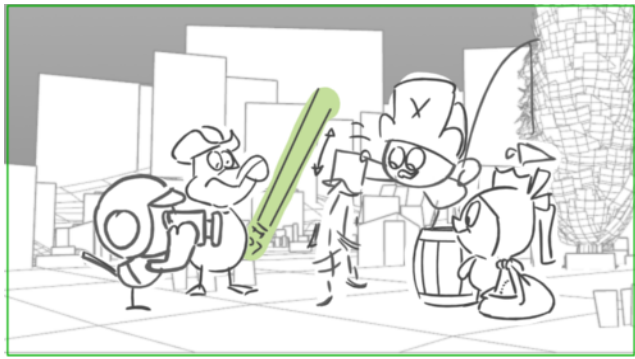

Action Notes

CAL verse un sachet de carottes rapées

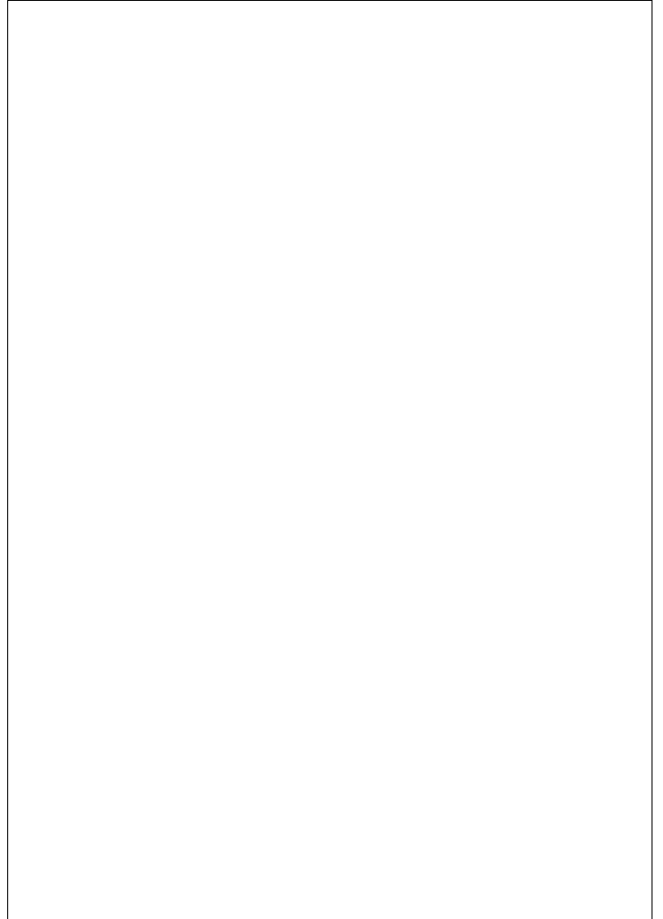
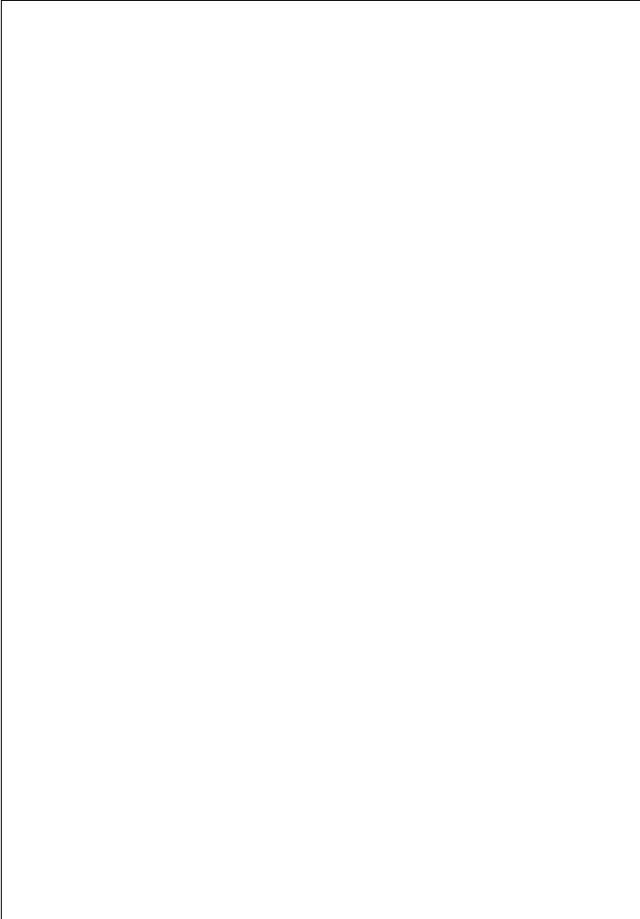

| Scene | Duration | Panel | Duration |
|-------|----------|-------|----------|
| 89 | 01:23 | 1 | 00:24 |

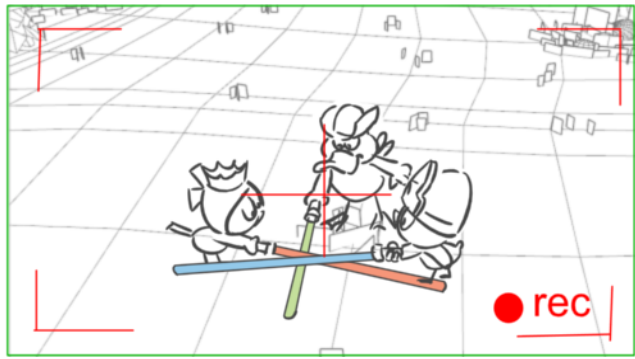

| Scene | Duration | Panel | Duration |
|-------|----------|-------|----------|
| 89 | 01:23 | 2 | 00:24 |

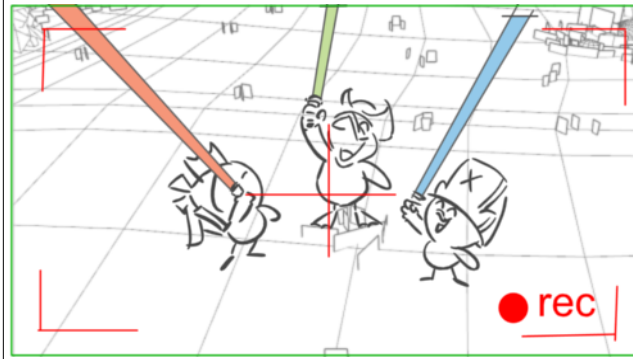

| Scene | Duration | Panel | Duration |
|-------|----------|-------|----------|
| 90 | 02:07 | 1 | 00:18 |

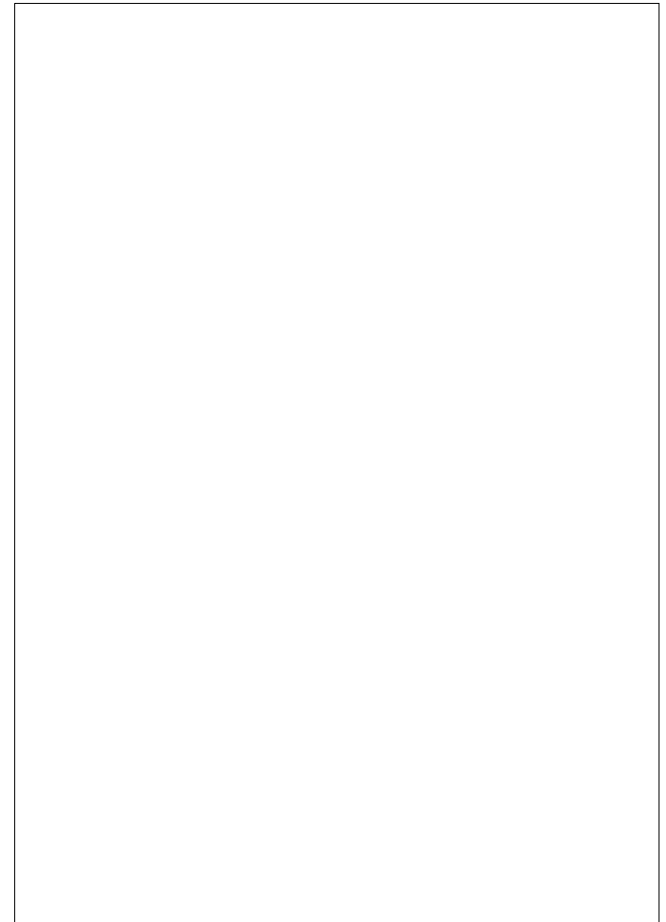
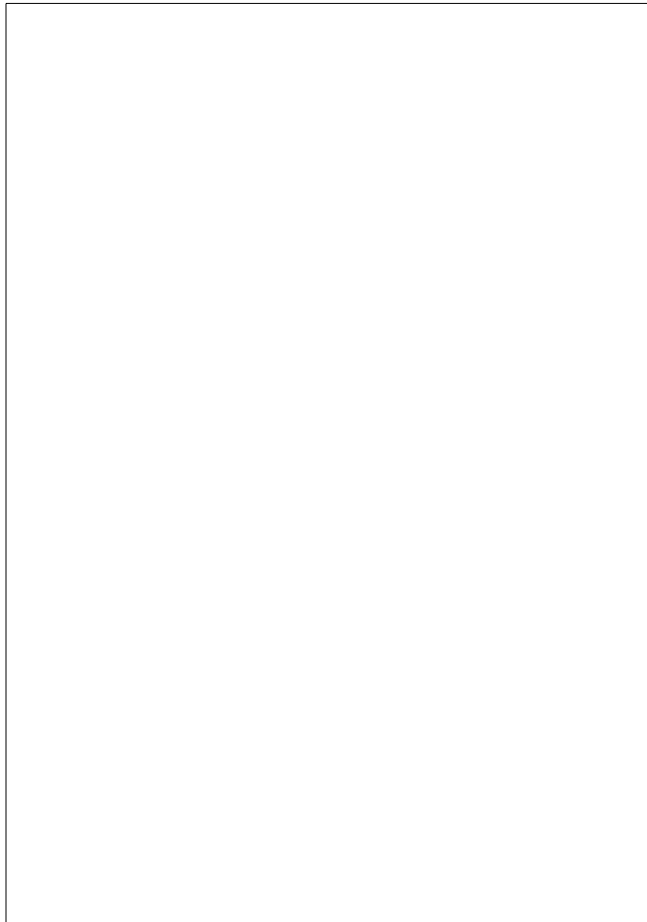

| Scene | Duration | Panel | Duration |
|-------|----------|-------|----------|
| 90 | 02:07 | 2 | 01:14 |



Dialogue
 64. PICK UP VALERIANO (lève le pouce, ravi)
 Ca y est !

| Scene | Duration | Panel | Duration |
|-------|----------|-------|----------|
| 91 | 05:04 | 1 | 01:00 |



Dialogue
 64. VALERIANO
 C'est dans la boîte, les amis !

| Scene | Duration | Panel | Duration |
|-------|----------|-------|----------|
| 91 | 05:04 | 2 | 01:11 |



Dialogue
 PICK UP
 youpi!!!!

| Scene | Duration | Panel | Duration |
|-------|----------|-------|----------|
| 91 | 05:04 | 3 | 01:00 |

| Scene | Duration | Panel | Duration |
|-------|----------|-------|----------|
| 91 | 05:04 | 4 | 01:18 |

NO PANEL

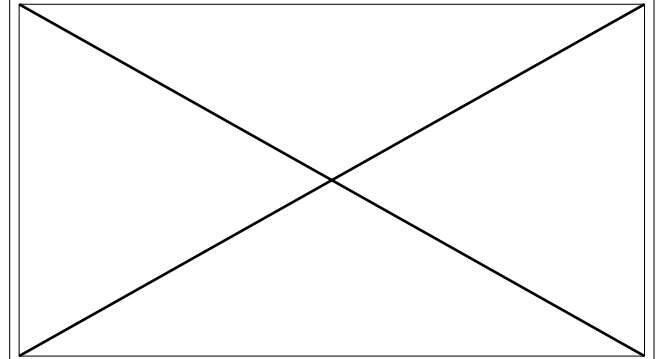
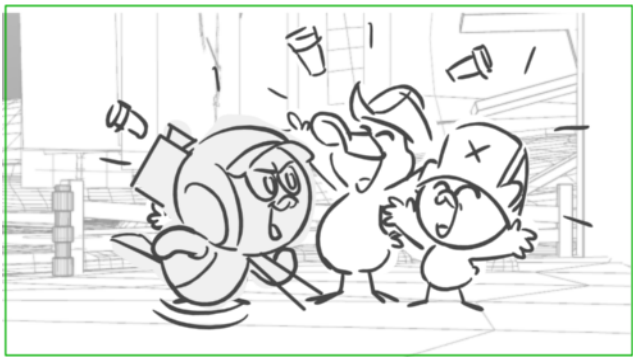

Dialogue
 PICK UP VALERIANO
 Pas de temps à perdre!



| | | | |
|-------|----------|-------|----------|
| Scene | Duration | Panel | Duration |
| 92 | 03:05 | 1 | 03:05 |

NO PANEL

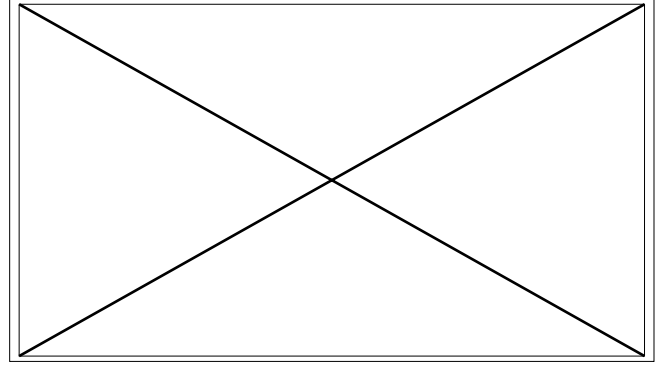
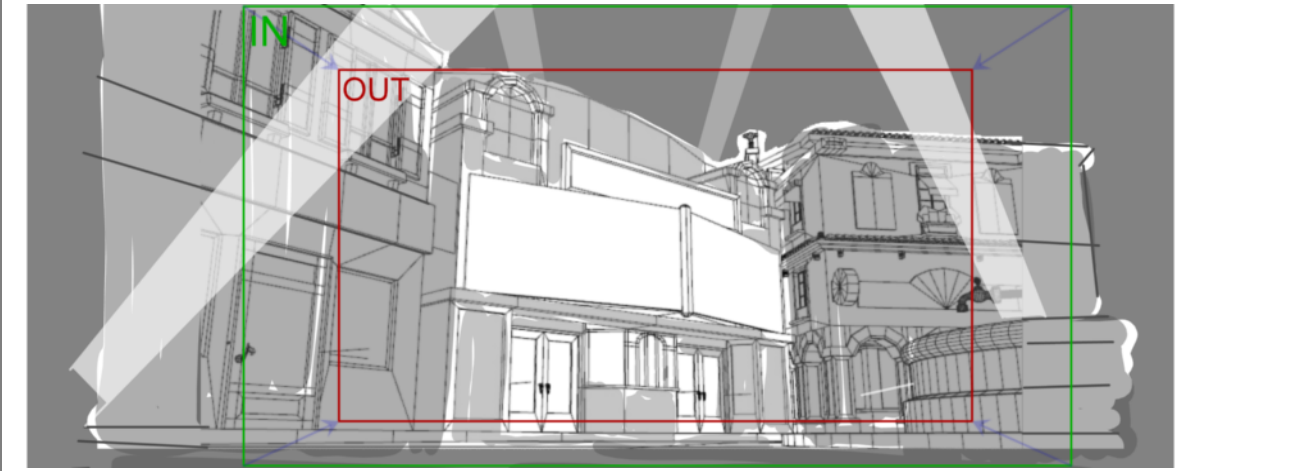

Dialogue
SFX MUSIQUE HOLLYWOODIENNE (style générique 20th century fox)

Action Notes
10. PLACE BASSE - CINEMA / EXT. SOIR

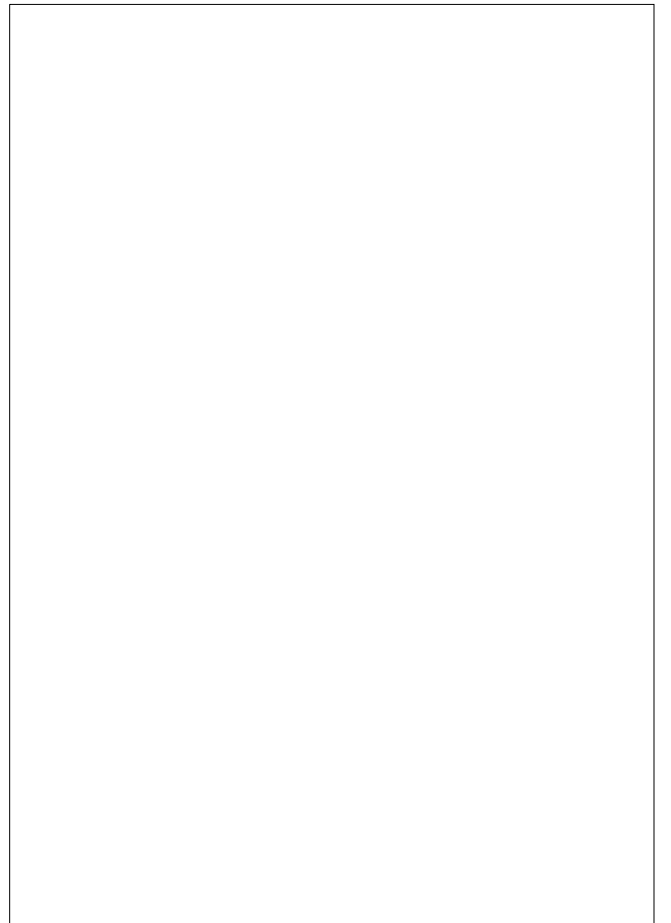

| Scene | Duration | Panel | Duration |
|-------|----------|-------|----------|
| 93 | 01:00 | 1 | 01:00 |

| Scene | Duration | Panel | Duration |
|-------|----------|-------|----------|
| 94 | 06:19 | 1 | 00:12 |

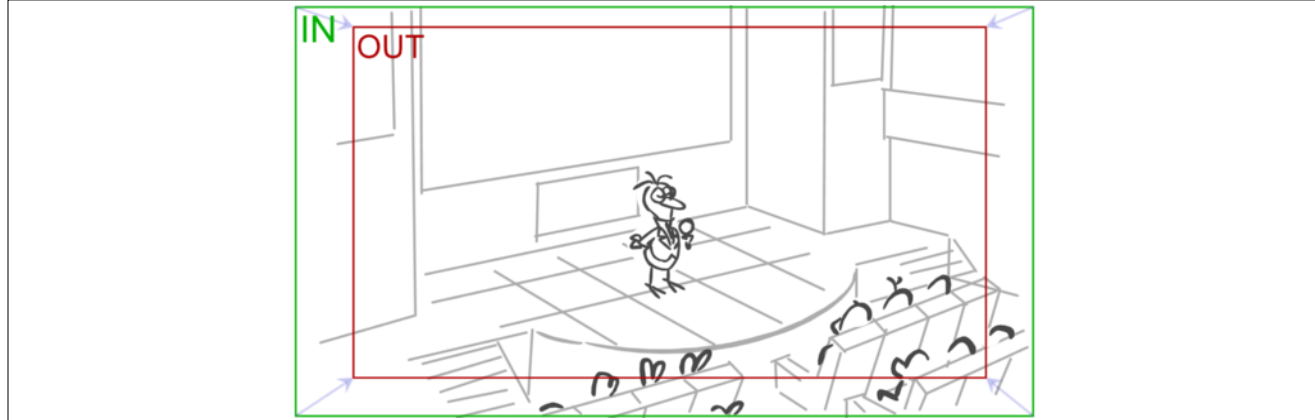

Dialogue
SFX MUSIQUE HOLLYWOODIENNE

Action Notes
11. PLACE BASSE - CINEMA / INT. SOIR

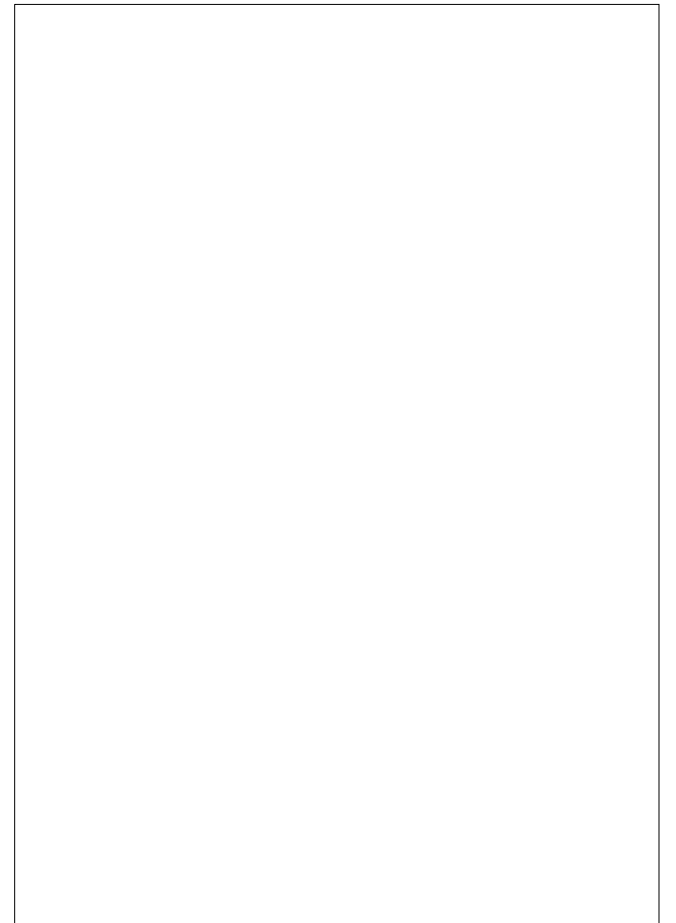

| Scene | Duration | Panel | Duration |
|-------|----------|-------|----------|
| 94 | 06:19 | 2 | 01:14 |



Dialogue
 65. MR KINOS
 Bienvenue à tous

| Scene | Duration | Panel | Duration |
|-------|----------|-------|----------|
| 94 | 06:19 | 3 | 02:08 |



Dialogue
 65. MR KINOS
 pour MON grand concours annuel du «
 Meilleur petit cinéaste » !

| Scene | Duration | Panel | Duration |
|-------|----------|-------|----------|
| 94 | 06:19 | 4 | 01:10 |



Dialogue
 65. MR KINOS
 pour MON grand concours annuel du «
 Meilleur petit cinéaste » !

| Scene | Duration | Panel | Duration |
|-------|----------|-------|----------|
| 94 | 06:19 | 5 | 01:00 |

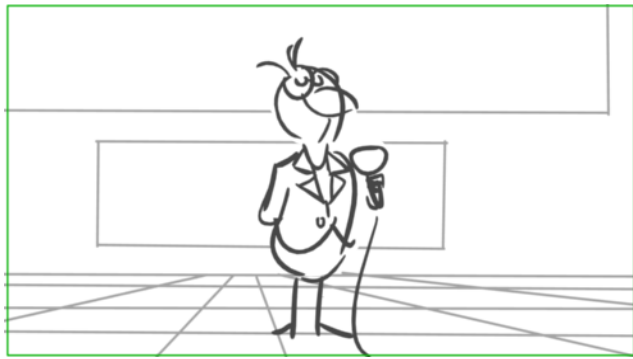

Dialogue
SFX BRAVO

| Scene | Duration | Panel | Duration |
|-------|----------|-------|----------|
| 95 | 01:09 | 1 | 01:09 |



Dialogue
SFX BRAVO

| Scene | Duration | Panel | Duration |
|-------|----------|-------|----------|
| 96 | 05:22 | 1 | 00:13 |



Dialogue
65. MR KINOS
Nous commençons tout de suite avec un premier film?

| Scene | Duration | Panel | Duration |
|-------|----------|-------|----------|
| 96 | 05:22 | 2 | 02:20 |

| Scene | Duration | Panel | Duration |
|-------|----------|-------|----------|
| 96 | 05:22 | 3 | 01:00 |

| Scene | Duration | Panel | Duration |
|-------|----------|-------|----------|
| 96 | 05:22 | 4 | 01:14 |



Dialogue
 65. MR KINOS
 Nous commençons tout de suite avec un premier film?

Dialogue
 65. MR KINOS
 Ah, tiens C'est curieux,

| Scene | Duration | Panel | Duration |
|-------|----------|-------|----------|
| 97 | 09:09 | 1 | 01:01 |

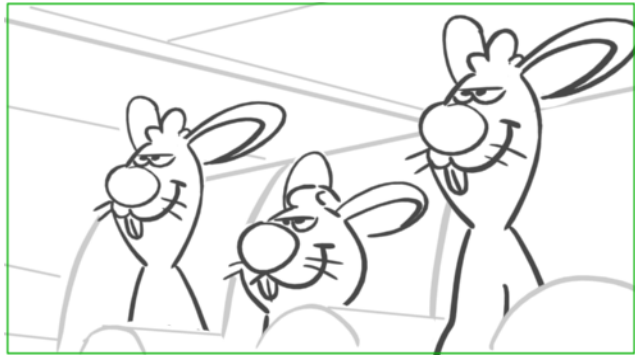

Dialogue

65. MR KINOS
il n'y a qu'un seul film!...

| Scene | Duration | Panel | Duration |
|-------|----------|-------|----------|
| 97 | 09:09 | 2 | 01:14 |



Dialogue

69. POT (odieux)
Arf arf arf !

| Scene | Duration | Panel | Duration |
|-------|----------|-------|----------|
| 97 | 09:09 | 3 | 01:01 |

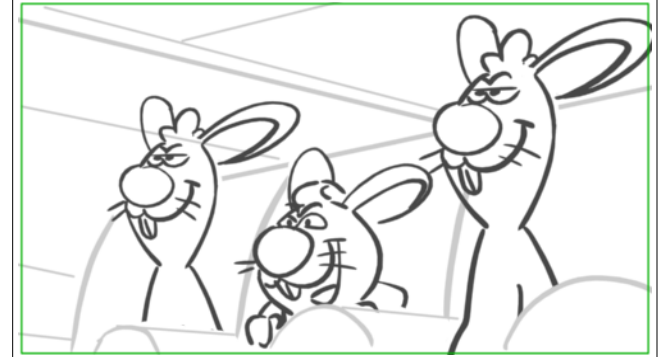

Dialogue

69. POT (odieux)
Pas de chance? Le tournage de Valériano
a été piraté !

| Scene | Duration | Panel | Duration |
|-------|----------|-------|----------|
| 97 | 09:09 | 4 | 02:21 |



Dialogue

69. POT (odieux)
 Pas de chance? Le tournage de Valériano a? été piraté !

| Scene | Duration | Panel | Duration |
|-------|----------|-------|----------|
| 97 | 09:09 | 5 | 01:03 |



Dialogue

69. POT (odieux)
 A nous les places de cinéma gratuites !

| Scene | Duration | Panel | Duration |
|-------|----------|-------|----------|
| 97 | 09:09 | 6 | 00:22 |



Dialogue

69. POT (odieux)
 A nous les places de cinéma gratuites !

| Scene | Duration | Panel | Duration |
|-------|----------|-------|----------|
| 97 | 09:09 | 7 | 00:22 |



Dialogue

69. POT (odieux)
A nous les places de cinéma gratuites !

| Scene | Duration | Panel | Duration |
|-------|----------|-------|----------|
| 98 | 10:08 | 1 | 02:17 |

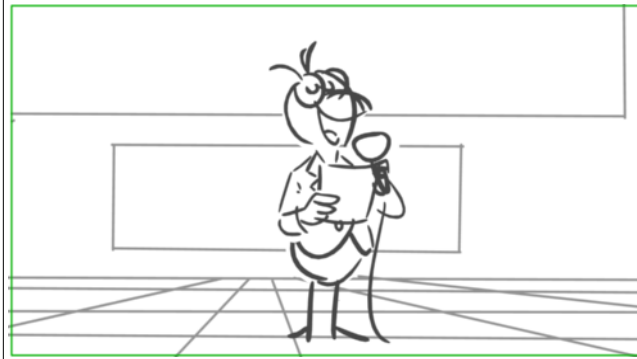

Dialogue

70. MR KINOS
Notre unique film s'intitule : «
L'ANNIVERSAIRE DE POT » de Pot, Cot et
Mot ! » Bonne projection !

| Scene | Duration | Panel | Duration |
|-------|----------|-------|----------|
| 98 | 10:08 | 2 | 01:12 |



Dialogue

70. MR KINOS
« L'ANNIVERSAIRE DE POT » de Pot, Cot
et Mot !

| Scene | Duration | Panel | Duration |
|-------|----------|-------|----------|
| 98 | 10:08 | 3 | 01:16 |

| Scene | Duration | Panel | Duration |
|-------|----------|-------|----------|
| 98 | 10:08 | 4 | 00:22 |

NO PANEL

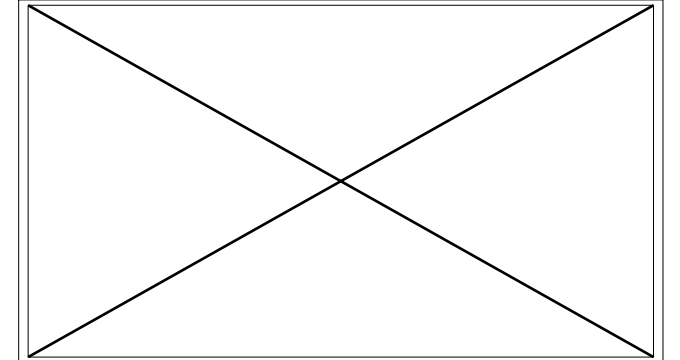

Dialogue
 70. MR KINOS
 « L'ANNIVERSAIRE DE POT » de Pot, Cot
 et Mot !

Dialogue
 70. MR KINOS
 « L'ANNIVERSAIRE DE POT » de Pot, Cot
 et Mot !



| | | | |
|-------|----------|-------|----------|
| Scene | Duration | Panel | Duration |
| 98 | 10:08 | 5 | 01:16 |

NO PANEL

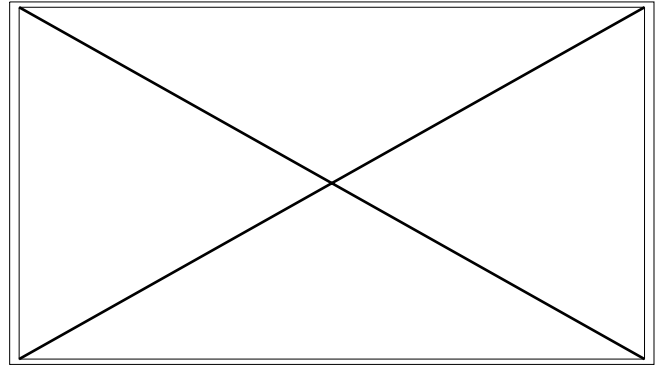
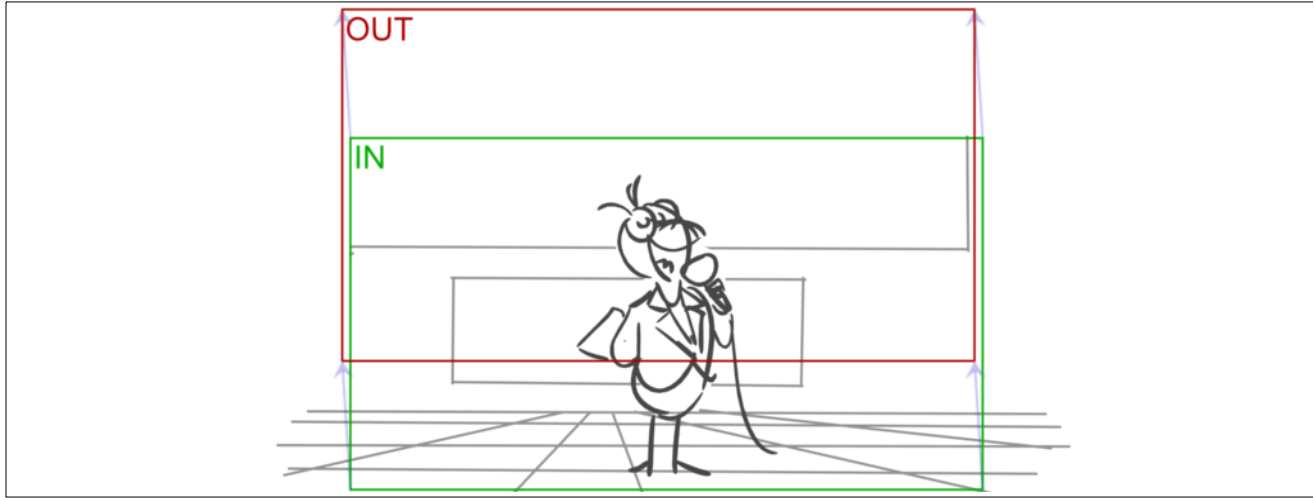

Dialogue
70. MR KINOS
» Bonne projection !

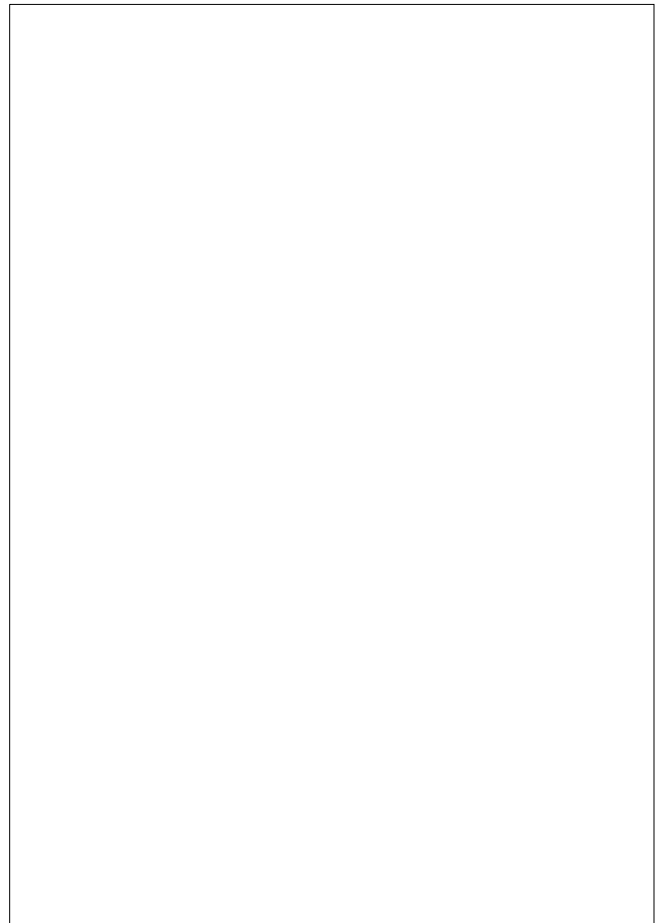



| Scene | Duration | Panel | Duration |
|-------|----------|-------|----------|
| 98 | 10:08 | 6 | 01:00 |



Dialogue
SFX BRAVO

| Scene | Duration | Panel | Duration |
|-------|----------|-------|----------|
| 98 | 10:08 | 7 | 01:00 |

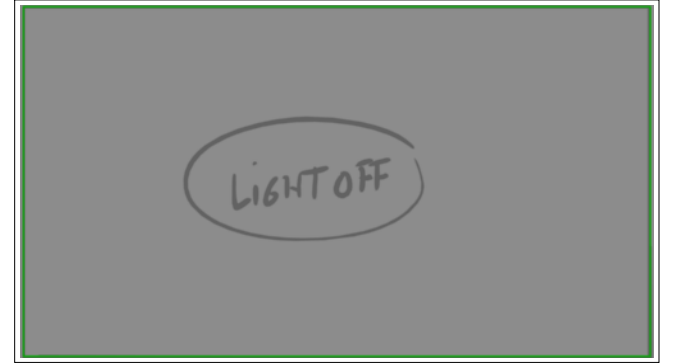

Dialogue
SFX BRAVO

| Scene | Duration | Panel | Duration |
|-------|----------|-------|----------|
| 99 | 12:00 | 1 | 01:00 |



Action Notes

A l'écran, Pot entouré de Cot et de Mot sont au bout d'une table, Un gâteau d'anniversaire à la crème et aux carottes trône au premier plan.

| Scene | Duration | Panel | Duration |
|-------|----------|-------|----------|
| 99 | 12:00 | 2 | 01:08 |



Dialogue

71. COT / MOT (en chœur)
Bon anniversaire Pot !

| Scene | Duration | Panel | Duration |
|-------|----------|-------|----------|
| 99 | 12:00 | 3 | 01:18 |



Dialogue

72. POT (jouant faux)
Ooh merci, les cousins !

| Scene | Duration | Panel | Duration |
|-------|----------|-------|----------|
| 99 | 12:00 | 4 | 01:00 |



Dialogue

72. POT (jouant faux)
Oh là là,

| Scene | Duration | Panel | Duration |
|-------|----------|-------|----------|
| 99 | 12:00 | 5 | 02:02 |



Dialogue

72. POT (jouant faux)
mais vous avez oublié les bougies
?!...

| Scene | Duration | Panel | Duration |
|-------|----------|-------|----------|
| 99 | 12:00 | 6 | 00:21 |



Dialogue

PICK UP MOT
Ciel!

| Scene | Duration | Panel | Duration |
|-------|----------|-------|----------|
| 99 | 12:00 | 7 | 00:19 |



Dialogue
 PICK UP MOT
 Mais ou ai je la tête?

| Scene | Duration | Panel | Duration |
|-------|----------|-------|----------|
| 99 | 12:00 | 8 | 00:17 |



Dialogue
 PICK UP MOT
 Mais ou ai je la tête?

| Scene | Duration | Panel | Duration |
|-------|----------|-------|----------|
| 99 | 12:00 | 9 | 00:01 |



Dialogue
 PICK UP MOT
 Mais ou ai je la tête?



| | | | |
|-------|----------|-------|----------|
| Scene | Duration | Panel | Duration |
| 99 | 12:00 | 10 | 00:09 |

NO PANEL

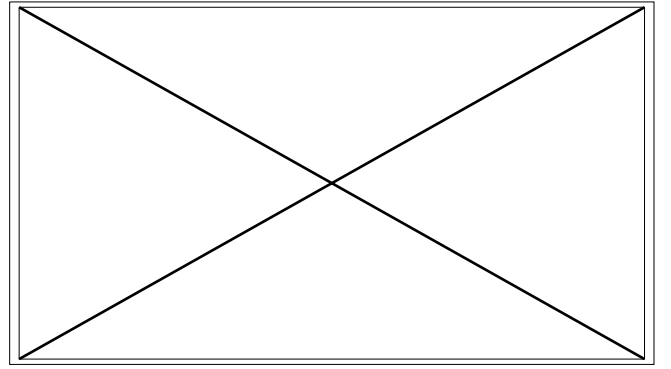
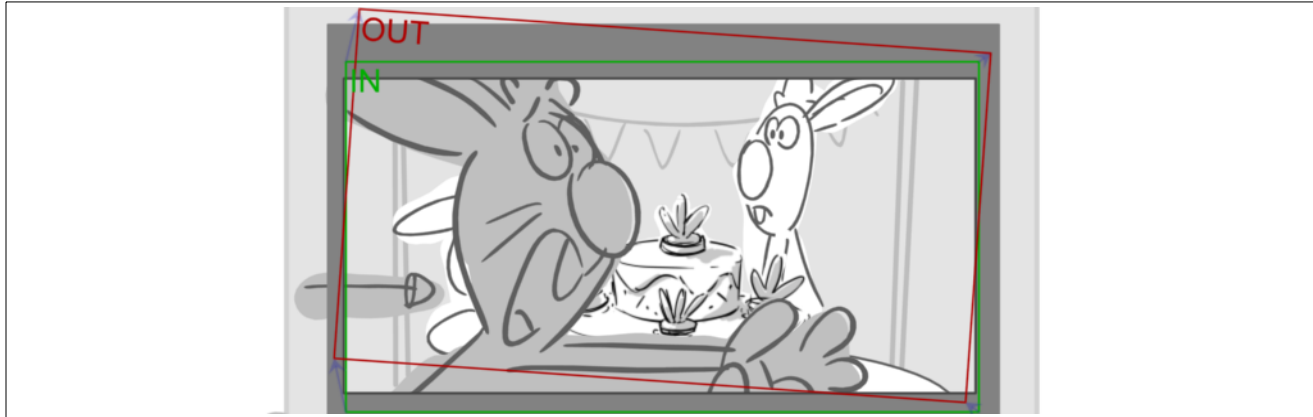

Dialogue
PICK UP MOT
Mais ou ai je la tête?

Action Notes
MOT heurte la CAM
CAM shake

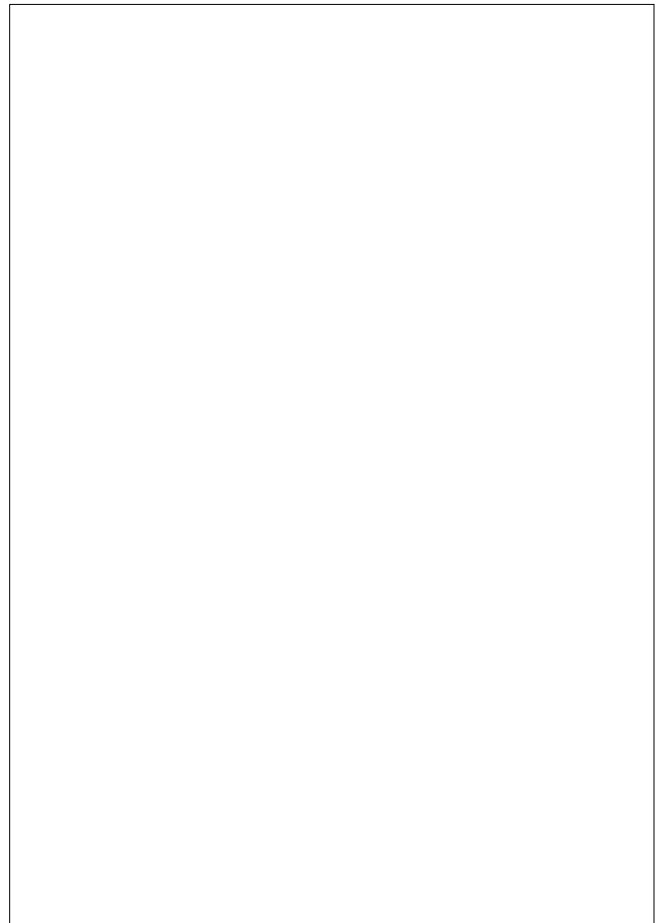



| | | | |
|-------|----------|-------|----------|
| Scene | Duration | Panel | Duration |
| 99 | 12:00 | 11 | 00:08 |

NO PANEL

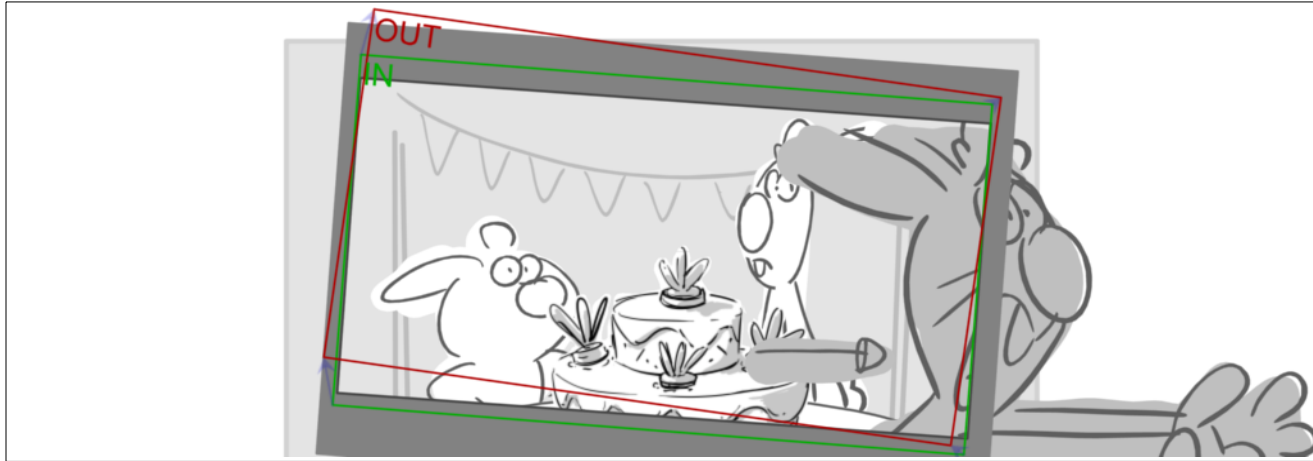

Dialogue
SFX CLANG!

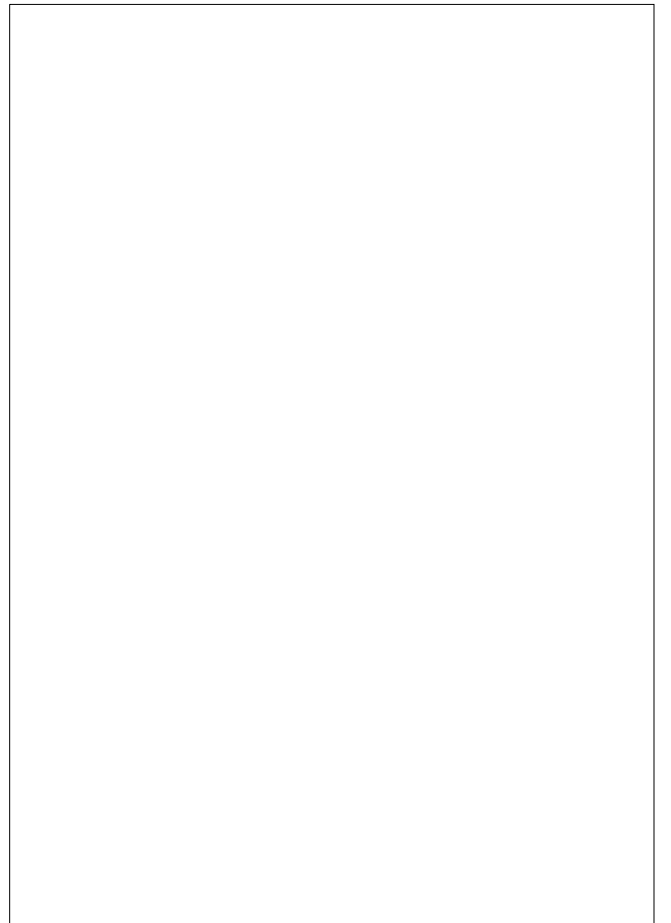
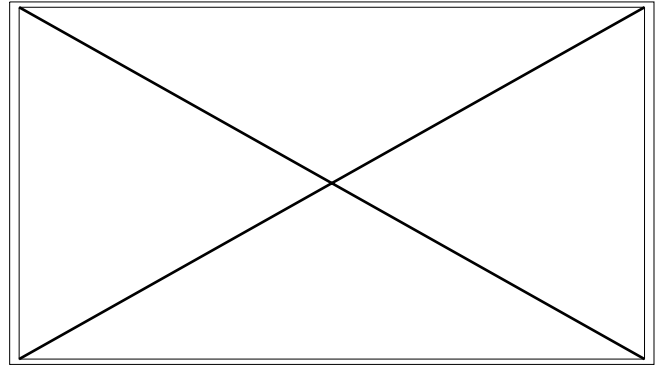



| | | | |
|-------|----------|-------|----------|
| Scene | Duration | Panel | Duration |
| 99 | 12:00 | 12 | 00:10 |

NO PANEL

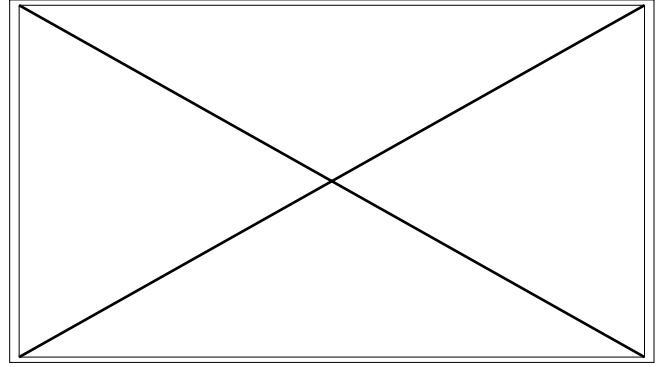
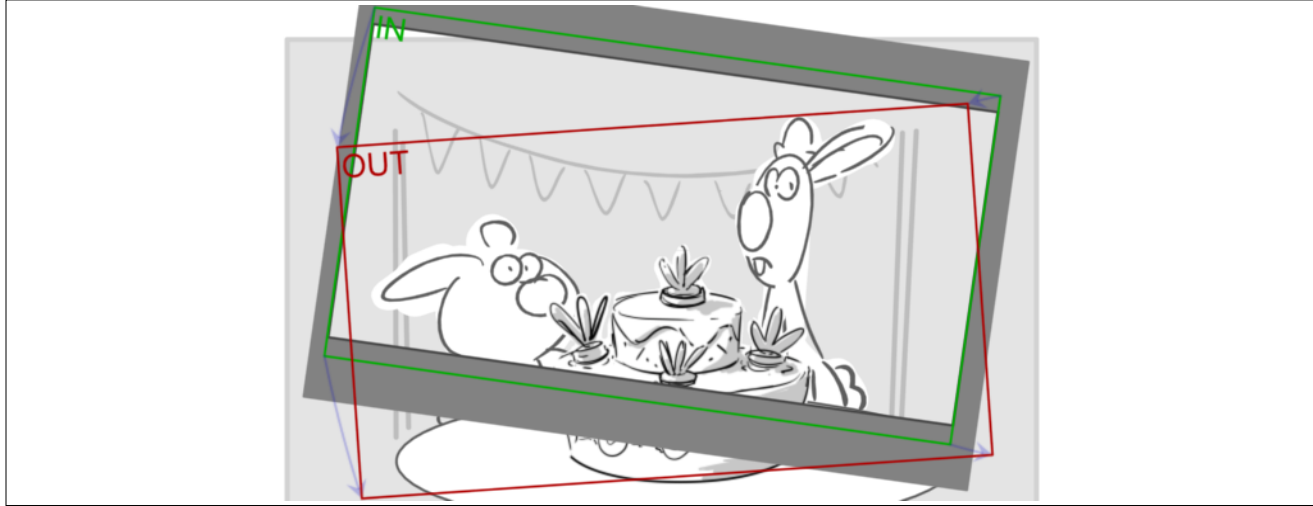

Action Notes
L?image pivote

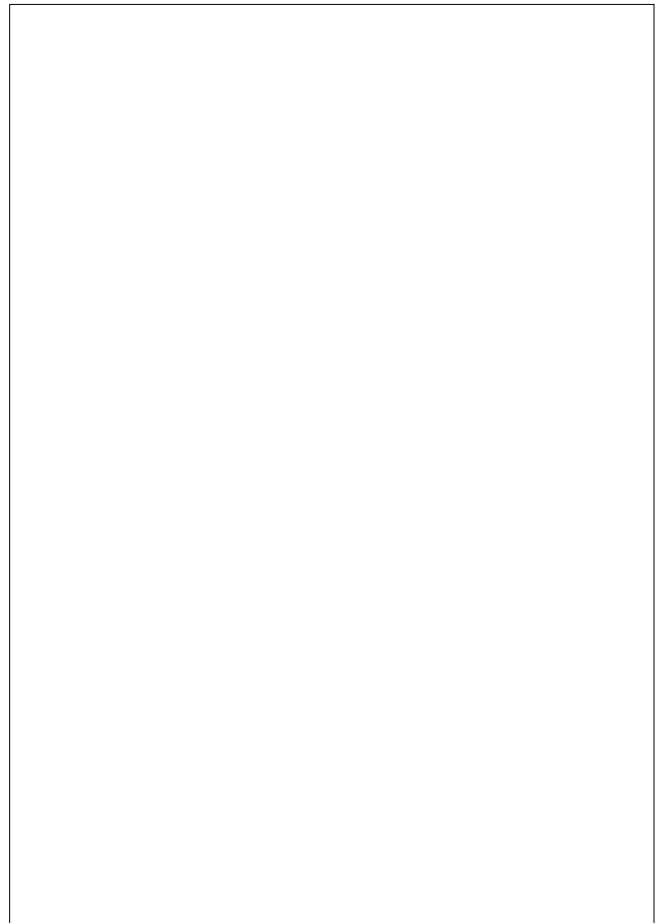

| Scene | Duration | Panel | Duration |
|-------|----------|-------|----------|
| 99 | 12:00 | 13 | 00:12 |

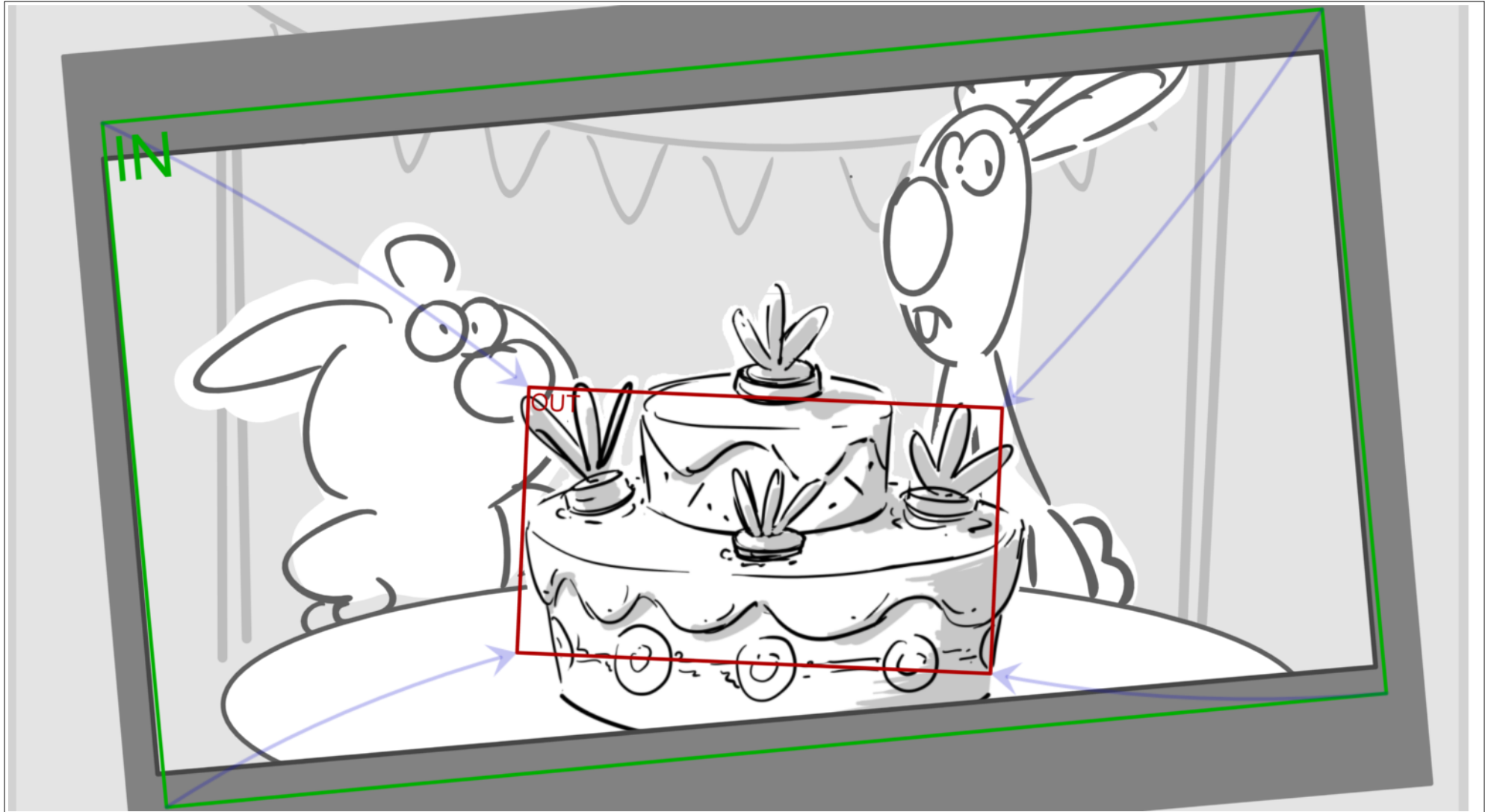



| | | | |
|-------|----------|-------|----------|
| Scene | Duration | Panel | Duration |
| 99 | 12:00 | 14 | 00:12 |

NO PANEL

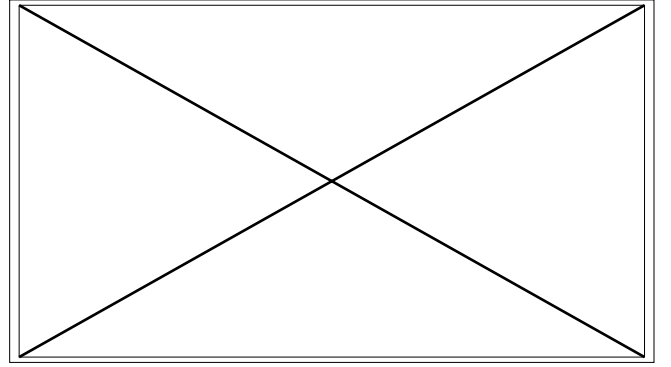
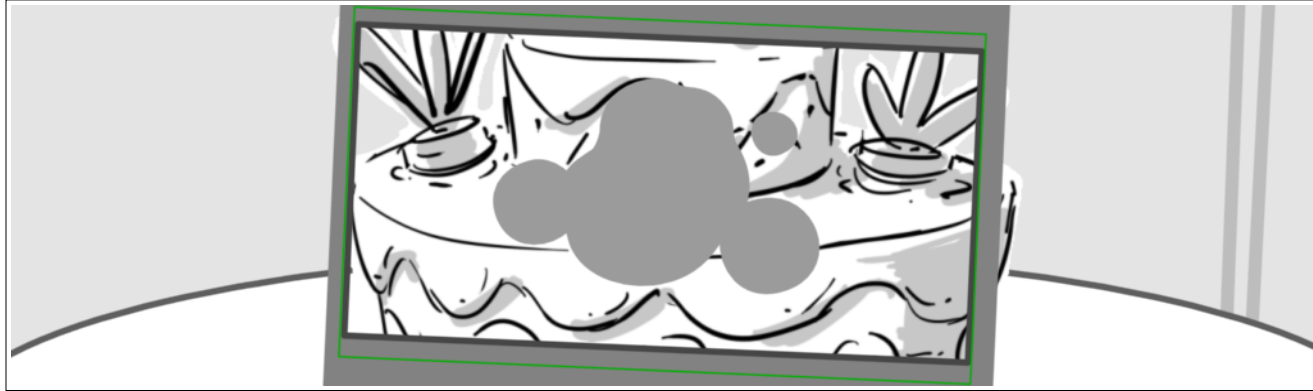

Dialogue
SFX SPLOTCH!

Action Notes
et? tombe dans le gâteau,

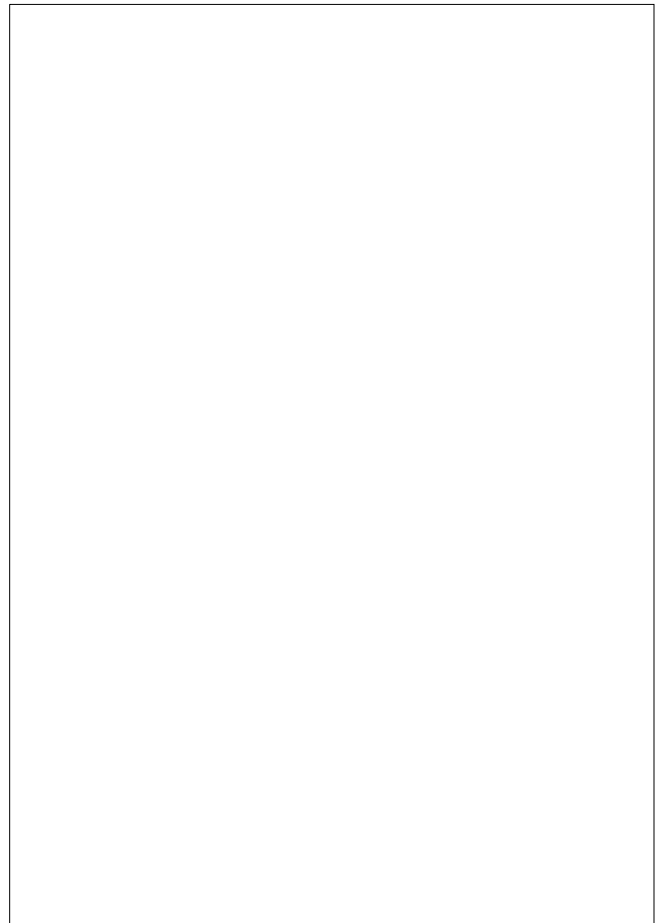



| | | | |
|-------|----------|-------|----------|
| Scene | Duration | Panel | Duration |
| 99 | 12:00 | 15 | 00:05 |

NO PANEL

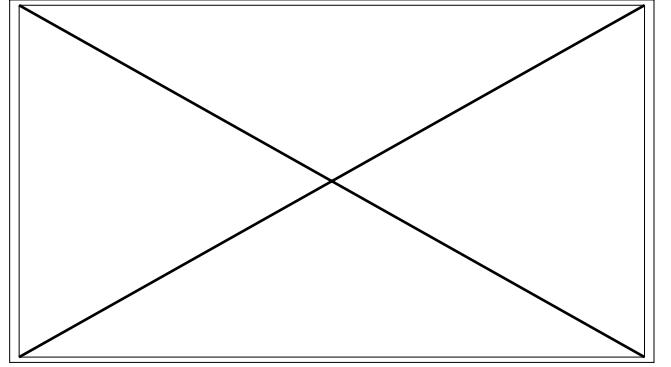
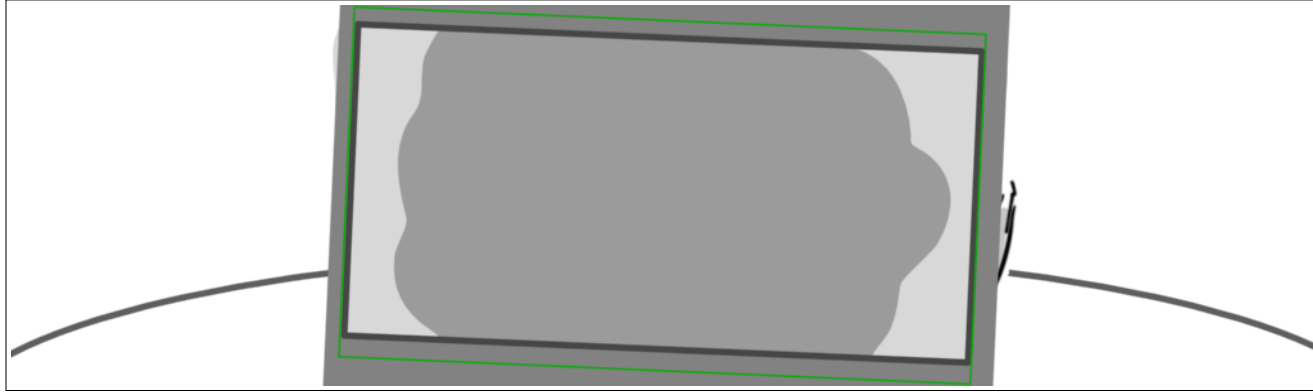

Dialogue
SFX SPLOTCH!

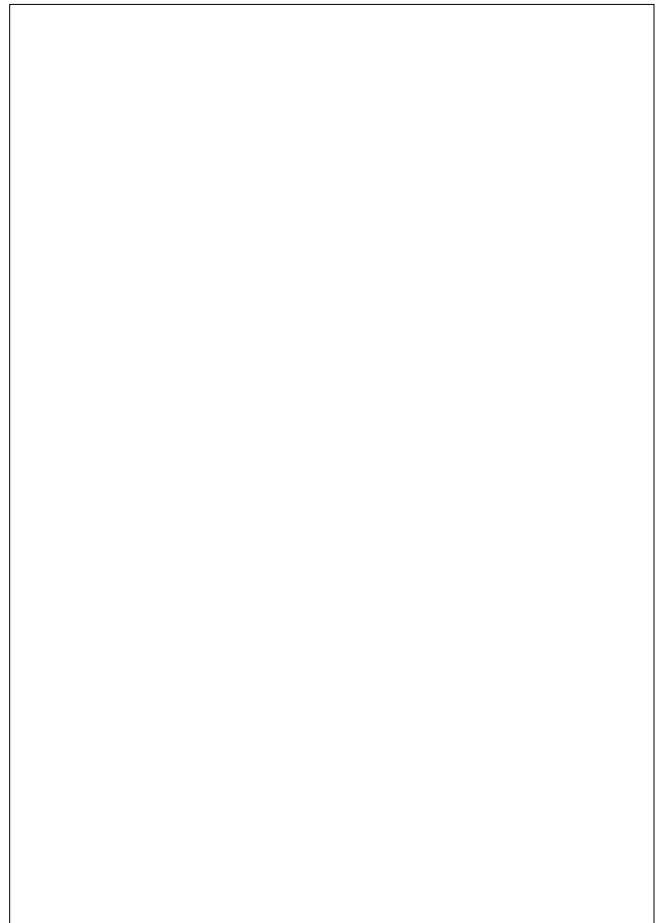



| Scene | Duration | Panel | Duration |
|-------|----------|-------|----------|
| 99 | 12:00 | 16 | 00:08 |

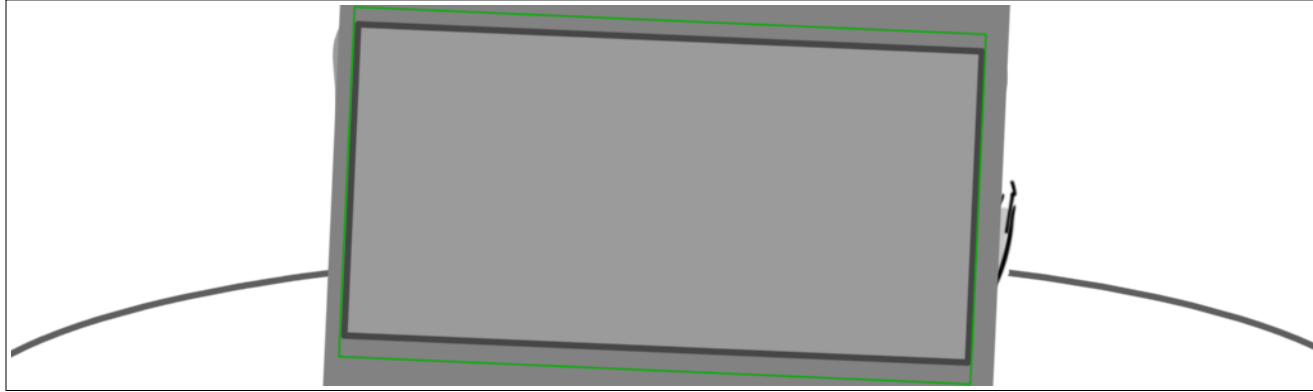

Dialogue
SFX SPLOTCH!

| Scene | Duration | Panel | Duration |
|-------|----------|-------|----------|
| 100 | 02:10 | 1 | 00:10 |



Action Notes
réac public perplexe!

| Scene | Duration | Panel | Duration |
|-------|----------|-------|----------|
| 100 | 02:10 | 2 | 01:00 |

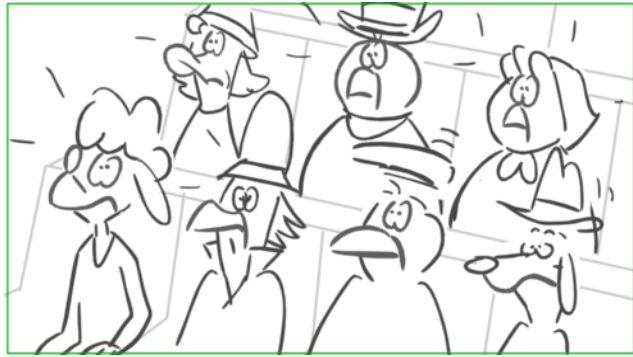

Action Notes

réac public perplexe!

| Scene | Duration | Panel | Duration |
|-------|----------|-------|----------|
| 100 | 02:10 | 3 | 01:00 |



Action Notes

Les spectateurs se regardent avec des mines d'incompréhension.

| Scene | Duration | Panel | Duration |
|-------|----------|-------|----------|
| 101 | 03:17 | 1 | 00:12 |



Dialogue

75. POT (terré dans son siège, grogne après Mot)
Grrr,

| Scene | Duration | Panel | Duration |
|-------|----------|-------|----------|
| 101 | 03:17 | 2 | 00:21 |

| Scene | Duration | Panel | Duration |
|-------|----------|-------|----------|
| 101 | 03:17 | 3 | 02:09 |

| Scene | Duration | Panel | Duration |
|-------|----------|-------|----------|
| 102 | 15:12 | 1 | 00:13 |

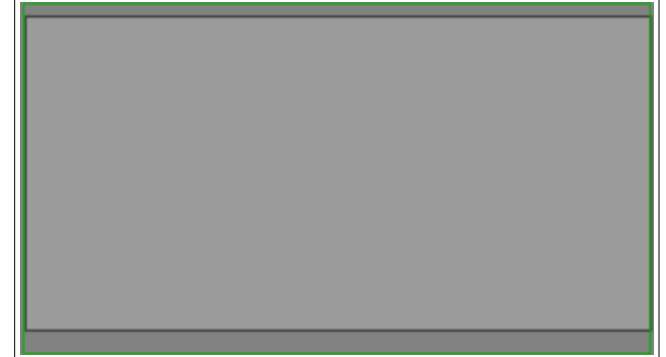
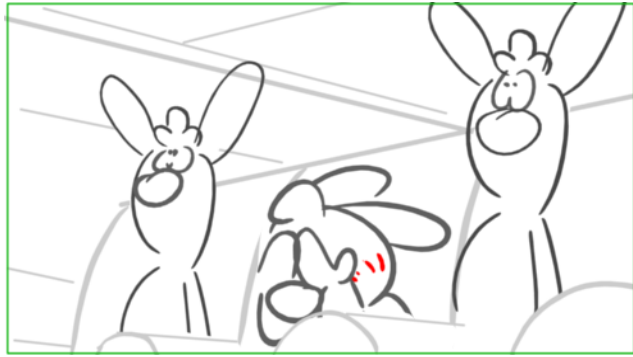

Dialogue

75. POT (terré dans son siège, grogne après Mot)

Grrr,

Dialogue

75. POT (terré dans son siège, grogne après Mot)

tu aurais pu éviter de faire tomber la caméra dans le gâteau !

| Scene | Duration | Panel | Duration |
|-------|----------|-------|----------|
| 102 | 15:12 | 2 | 00:15 |

| Scene | Duration | Panel | Duration |
|-------|----------|-------|----------|
| 102 | 15:12 | 3 | 00:13 |

| Scene | Duration | Panel | Duration |
|-------|----------|-------|----------|
| 102 | 15:12 | 4 | 00:16 |

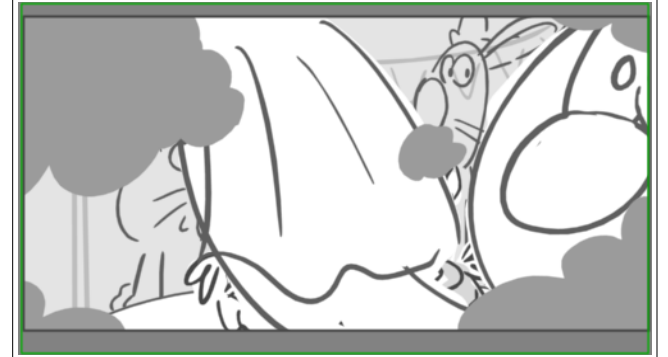
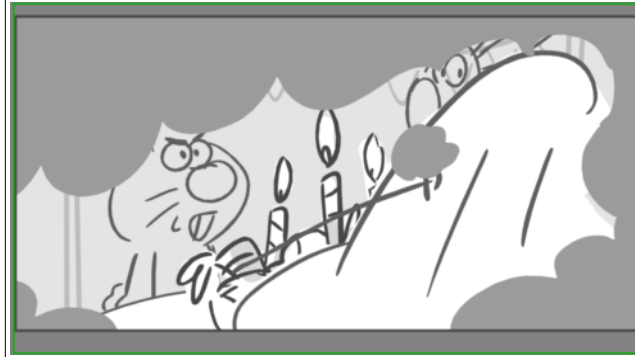

Dialogue
SWICH-WICH-WHICH !

Dialogue
SWICH-WICH-WHICH !

Dialogue
SWICH-WICH-WHICH !

Action Notes
Mot essuie l'objectif avec une serviette.



| Scene | Duration | Panel | Duration |
|-------|----------|-------|----------|
| 102 | 15:12 | 5 | 00:15 |

| Scene | Duration | Panel | Duration |
|-------|----------|-------|----------|
| 102 | 15:12 | 6 | 00:06 |

| Scene | Duration | Panel | Duration |
|-------|----------|-------|----------|
| 102 | 15:12 | 7 | 00:14 |



Dialogue
SWICH-WICH-WHICH !

Dialogue
SWICH-WICH-WHICH !

Action Notes
BLINK

Dialogue
SWICH-WICH-WHICH !

| Scene | Duration | Panel | Duration |
|-------|----------|-------|----------|
| 102 | 15:12 | 8 | 01:00 |



Dialogue

MOT
Ahem!

| Scene | Duration | Panel | Duration |
|-------|----------|-------|----------|
| 102 | 15:12 | 9 | 01:00 |



| Scene | Duration | Panel | Duration |
|-------|----------|-------|----------|
| 102 | 15:12 | 10 | 01:00 |



Dialogue

PICK UP MOTvoix
grésillante/assourdie/passant du grave
à l'aigu)
Vas y! tu peux souffler <tZZRRZZes
bougies!<ZZRRZZ>

| Scene | Duration | Panel | Duration |
|-------|----------|-------|----------|
| 102 | 15:12 | 11 | 01:00 |



| Scene | Duration | Panel | Duration |
|-------|----------|-------|----------|
| 102 | 15:12 | 12 | 01:00 |



| Scene | Duration | Panel | Duration |
|-------|----------|-------|----------|
| 102 | 15:12 | 13 | 01:00 |

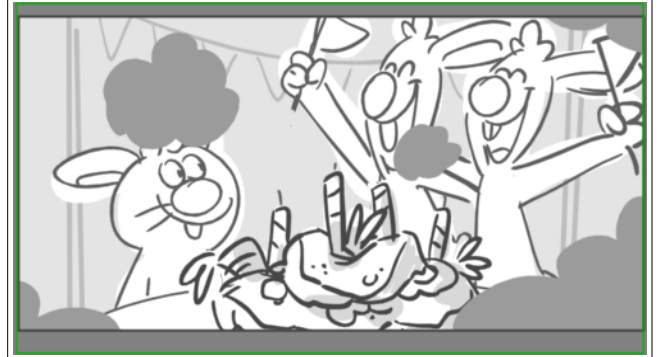

Dialogue

74. COT (voix grésillante/assourdie/passant du grave à l'aigu)
 Bra<ZZRRRZZ>vooo!!! <ZZRRRZZ>..

| Scene | Duration | Panel | Duration |
|-------|----------|-------|----------|
| 102 | 15:12 | 14 | 02:12 |



Dialogue

PICK UP POT (jouant faux)
 Merci les cousins! <ZZRRRZZ> A l'année
 prochaine!

| Scene | Duration | Panel | Duration |
|-------|----------|-------|----------|
| 102 | 15:12 | 15 | 01:08 |

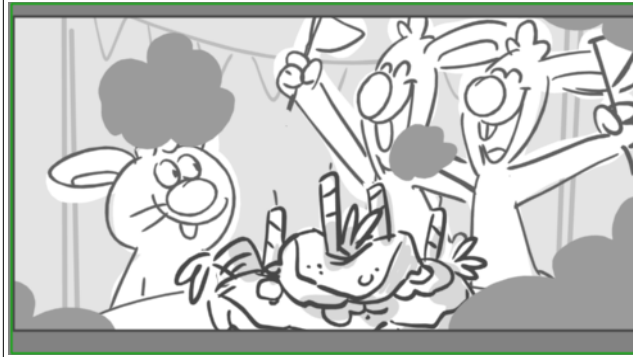

Dialogue

PICK UP COT et MOT (jouant faux)
 A l'année prochaine POT!

| Scene | Duration | Panel | Duration |
|-------|----------|-------|----------|
| 102 | 15:12 | 16 | 01:00 |



Dialogue

PICK UP POT (jouant faux)
 Au revoir les cousins! <ZZRRRZZ> A
 l'année prochaine!

| Scene | Duration | Panel | Duration |
|-------|----------|-------|----------|
| 102 | 15:12 | 17 | 01:00 |

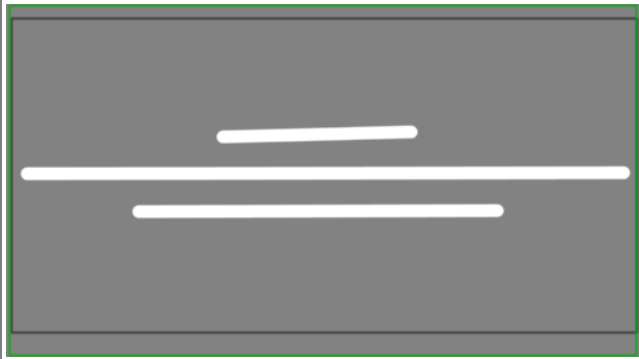

Dialogue

PICK UP POT (jouant faux)
 Au revoir les cousins! <ZZRRRZZ> A
 l'année prochaine!

| Scene | Duration | Panel | Duration |
|-------|----------|-------|----------|
| 103 | 04:07 | 1 | 01:05 |



| Scene | Duration | Panel | Duration |
|-------|----------|-------|----------|
| 103 | 04:07 | 2 | 01:13 |



Action Notes

APPLAUDISSEMENTS timides.

| Scene | Duration | Panel | Duration |
|-------|----------|-------|----------|
| 103 | 04:07 | 3 | 00:11 |



Dialogue
 ARTURO/ MOTHER COT (enthousiastes)
 Bravo!!!!

| Scene | Duration | Panel | Duration |
|-------|----------|-------|----------|
| 103 | 04:07 | 4 | 01:03 |



Dialogue
 SFX Applaudissements marqués (très rapides)

| Scene | Duration | Panel | Duration |
|-------|----------|-------|----------|
| 104 | 03:00 | 1 | 01:08 |



Action Notes
 Les parents des lapinets applaudissent à tout rompre!

| Scene | Duration | Panel | Duration |
|-------|----------|-------|----------|
| 104 | 03:00 | 2 | 01:17 |

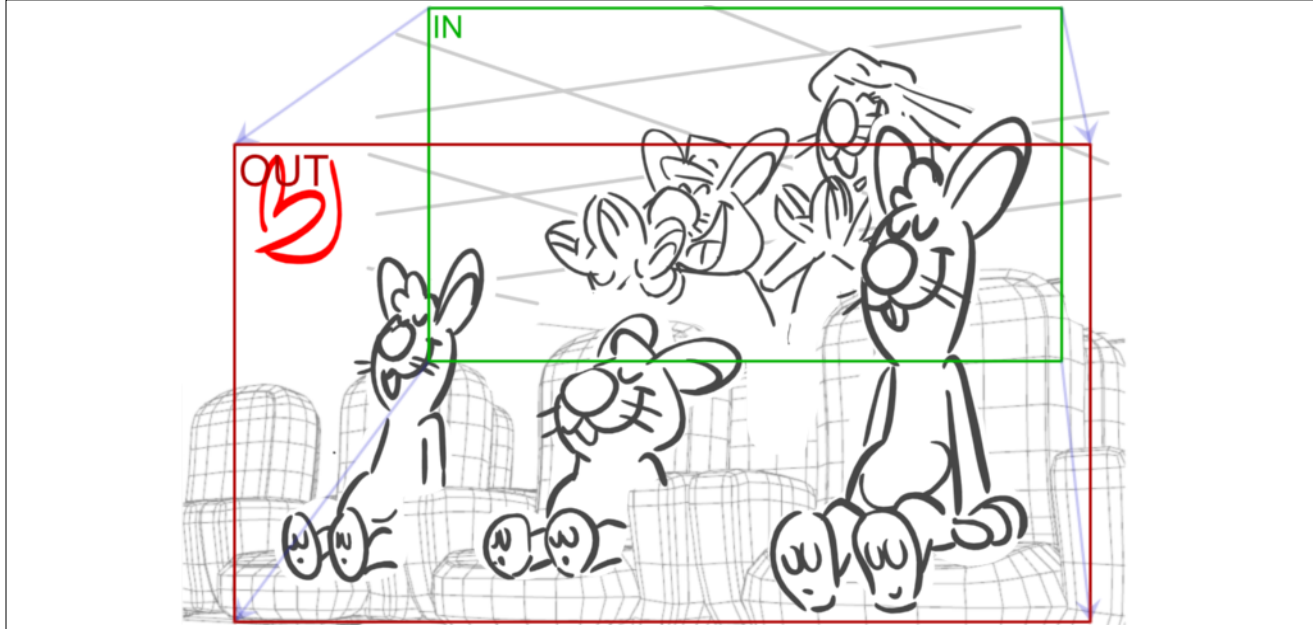

| Scene | Duration | Panel | Duration |
|-------|----------|-------|----------|
| 105 | 15:01 | 1 | 02:13 |



Dialogue

76. MR KINOS (un peu décontenancé, au micro)
 Merci aux cousins Lapinet pour ce film très?

| | | | |
|-------|----------|-------|----------|
| Scene | Duration | Panel | Duration |
| 105 | 15:01 | 2 | 01:00 |

**Dialogue**

76. MR KINOS (un peu décontenancé, au micro)
Hum,

NO PANEL

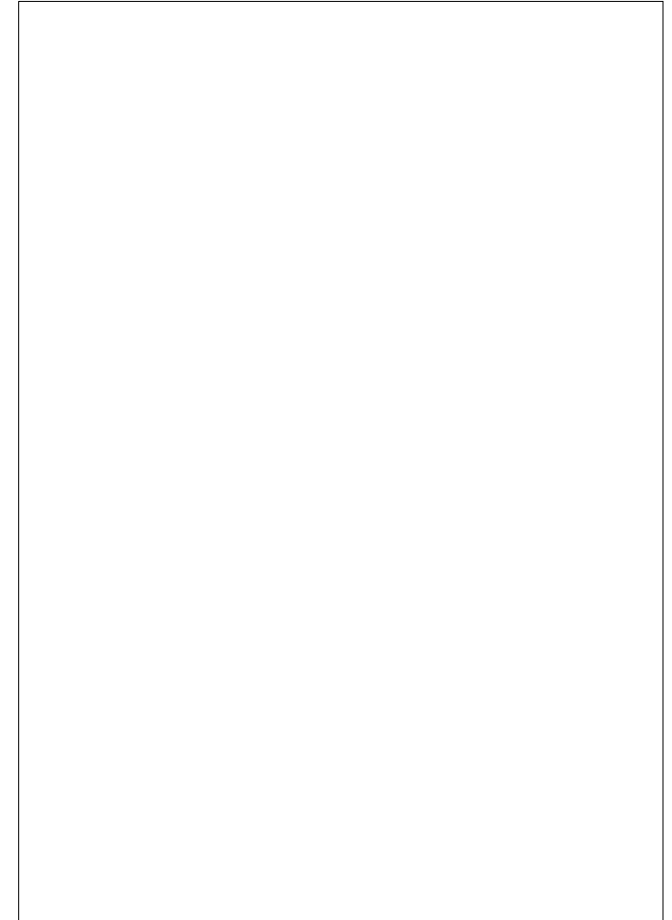
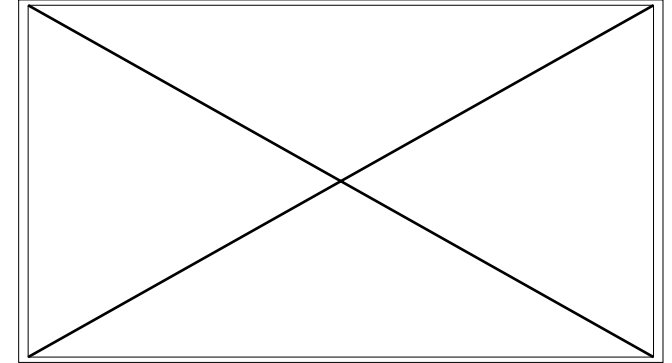

| Scene | Duration | Panel | Duration |
|-------|----------|-------|----------|
| 105 | 15:01 | 3 | 01:09 |

| Scene | Duration | Panel | Duration |
|-------|----------|-------|----------|
| 105 | 15:01 | 4 | 01:00 |

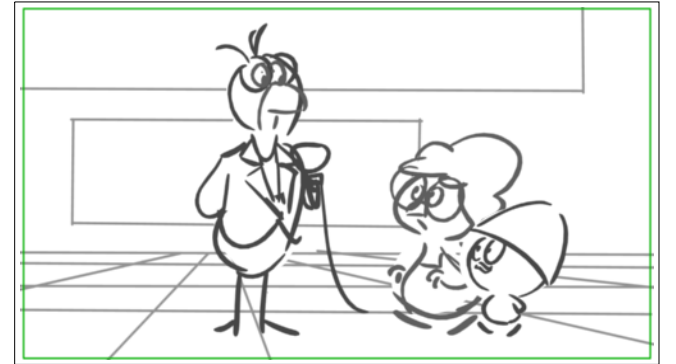

Dialogue

76. MR KINOS (un peu décontenancé, au micro)
 ?très? crémeux !

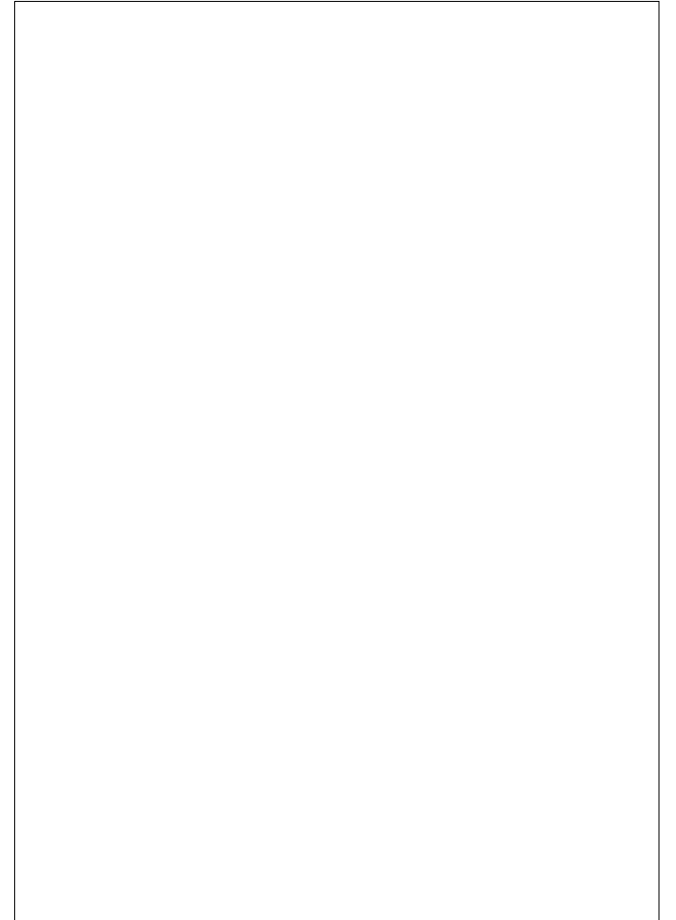

| Scene | Duration | Panel | Duration |
|-------|----------|-------|----------|
| 105 | 15:01 | 5 | 01:00 |

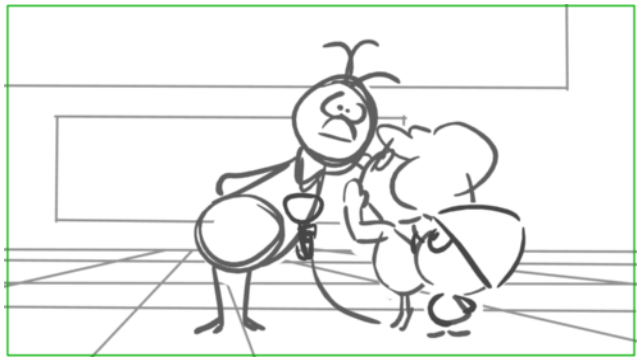

Action Notes

GIGI parle à l'oreille de KINOS

| Scene | Duration | Panel | Duration |
|-------|----------|-------|----------|
| 105 | 15:01 | 6 | 01:00 |

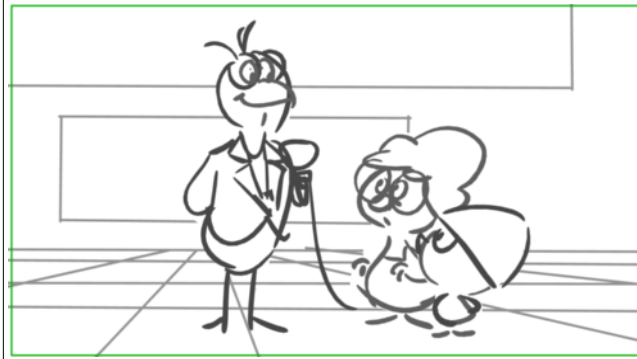

| Scene | Duration | Panel | Duration |
|-------|----------|-------|----------|
| 105 | 15:01 | 7 | 02:16 |

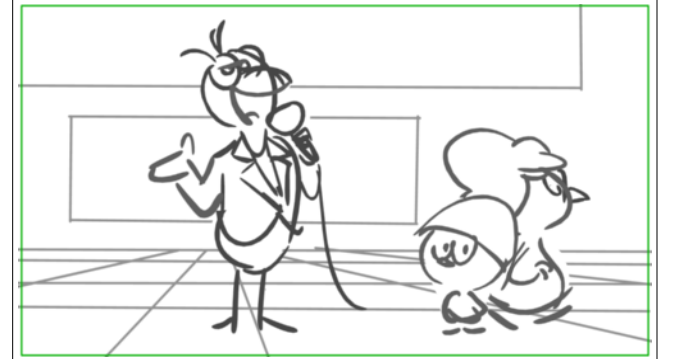

Dialogue

77. MR KINOS (annonçant au micro)
Mesdames et Messieurs,

| Scene | Duration | Panel | Duration |
|-------|----------|-------|----------|
| 105 | 15:01 | 8 | 04:13 |

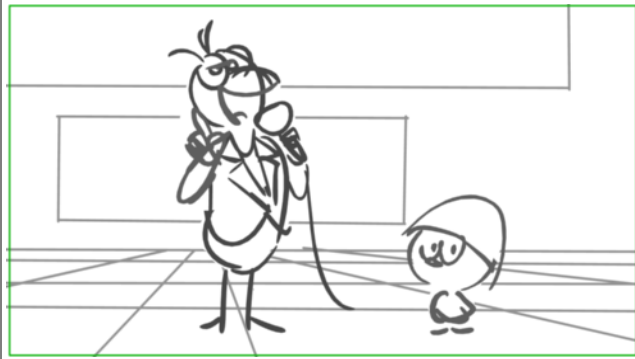

Dialogue

77. MR KINOS (annonçant au micro)
On m'annonce que nous avons reçu un film de dernière minute :

| Scene | Duration | Panel | Duration |
|-------|----------|-------|----------|
| 106 | 03:04 | 1 | 01:00 |

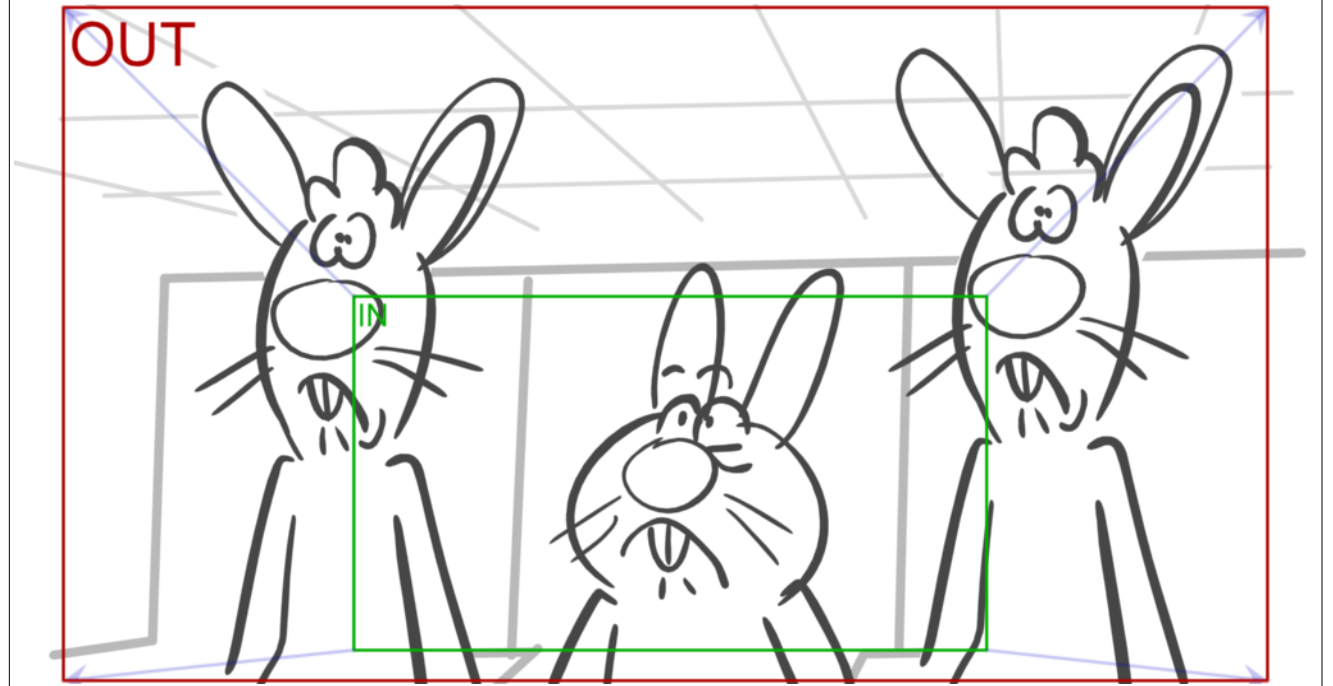

Dialogue

77. MR KINOS (annonçant au micro)
Celui de Valériano !

| Scene | Duration | Panel | Duration |
|-------|----------|-------|----------|
| 106 | 03:04 | 2 | 01:05 |

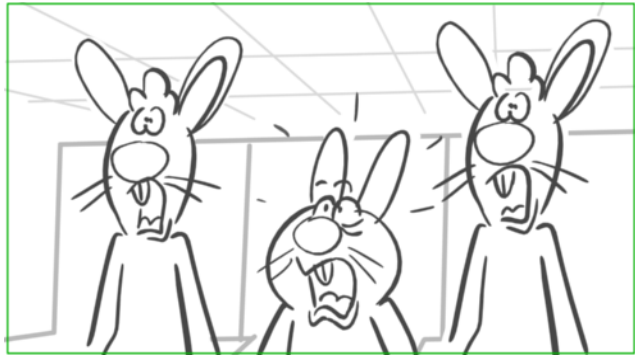

Dialogue

78. POT/COT/MOT (s'arrêtant net de mâchouiller leurs carottes)
HEIIINN ?!!

| Scene | Duration | Panel | Duration |
|-------|----------|-------|----------|
| 106 | 03:04 | 3 | 00:24 |

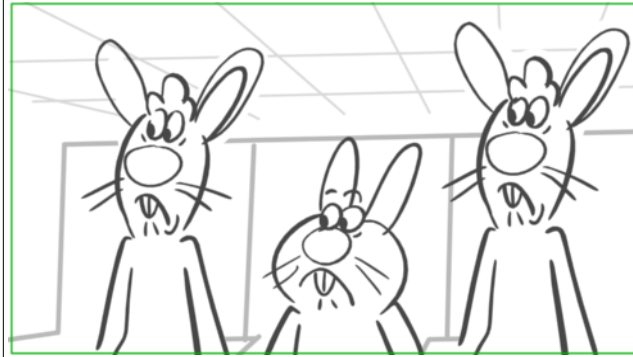

Dialogue

79. CALIMERO (au micro de Mr Kinos)
Oui, c'est Valériano qui l'a fait !

| Scene | Duration | Panel | Duration |
|-------|----------|-------|----------|
| 107 | 02:20 | 1 | 00:12 |

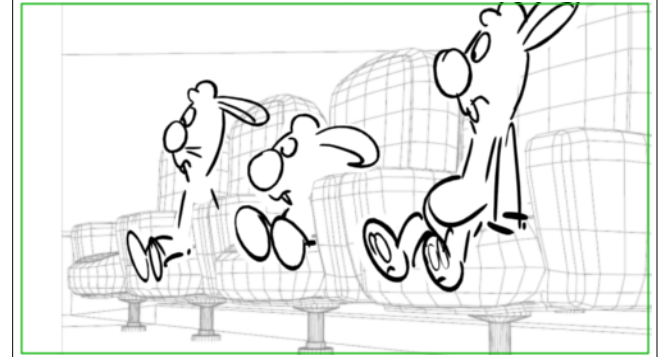

Dialogue

79. CALIMERO (au micro de Mr Kinos)
Oui, c'est Valériano qui l'a fait !

| Scene | Duration | Panel | Duration |
|-------|----------|-------|----------|
| 107 | 02:20 | 2 | 00:21 |

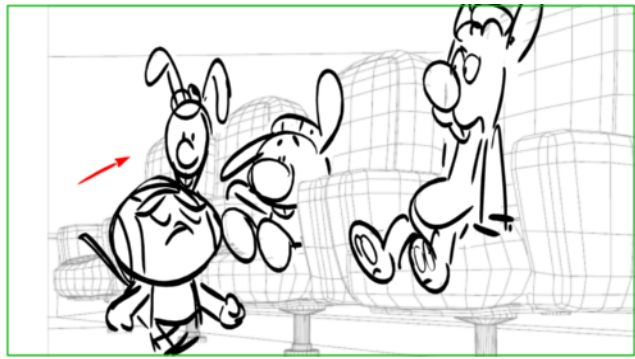

| Scene | Duration | Panel | Duration |
|-------|----------|-------|----------|
| 107 | 02:20 | 3 | 00:21 |



| Scene | Duration | Panel | Duration |
|-------|----------|-------|----------|
| 107 | 02:20 | 4 | 00:16 |

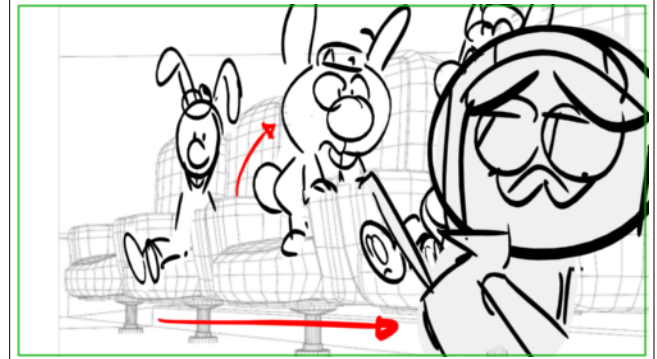

Action Notes

VALERIANO passe devant les lapinet

| Scene | Duration | Panel | Duration |
|-------|----------|-------|----------|
| 108 | 06:13 | 1 | 01:16 |

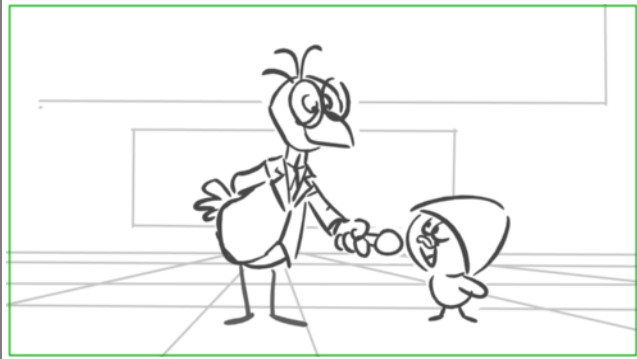

Dialogue
 79. CALIMERO (au micro de Mr Kinos)
 Et son film s'appelle? «

| Scene | Duration | Panel | Duration |
|-------|----------|-------|----------|
| 108 | 06:13 | 2 | 02:13 |

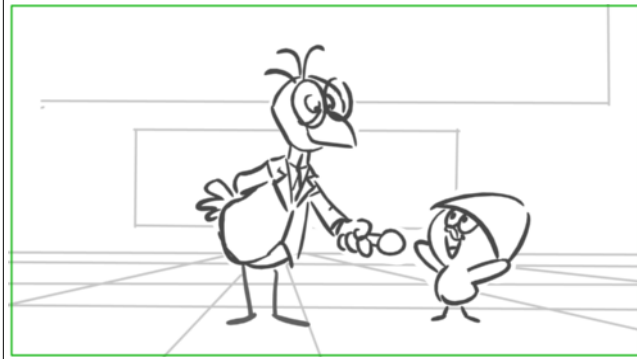

Dialogue
 79. CALIMERO (au micro de Mr Kinos)
 L'INVASION DES CAROTTES GEANTES DE
 L'ESPACE. »

| Scene | Duration | Panel | Duration |
|-------|----------|-------|----------|
| 108 | 06:13 | 3 | 00:13 |

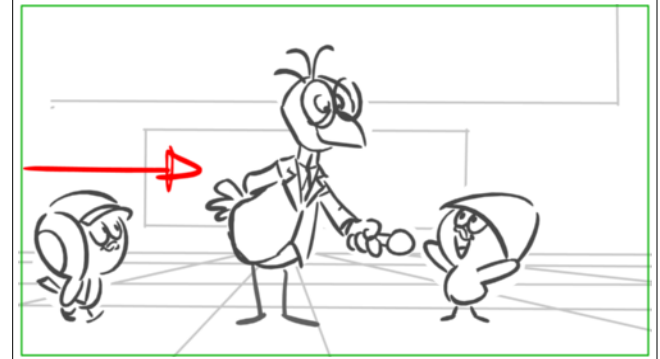

| Scene | Duration | Panel | Duration |
|-------|----------|-------|----------|
| 108 | 06:13 | 4 | 00:13 |

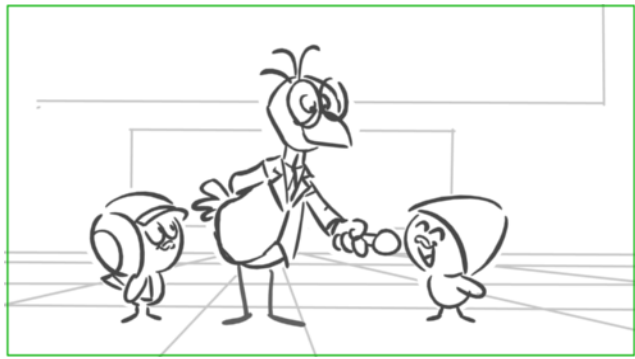

| Scene | Duration | Panel | Duration |
|-------|----------|-------|----------|
| 108 | 06:13 | 5 | 01:08 |

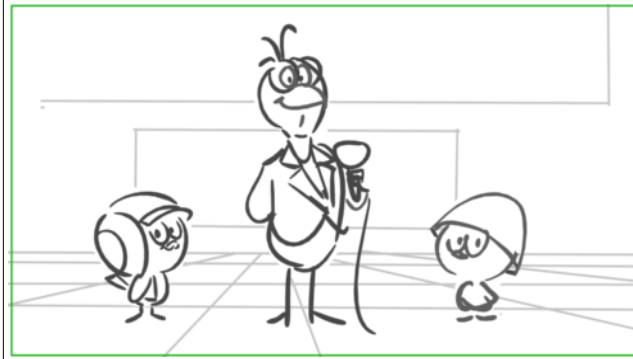

| Scene | Duration | Panel | Duration |
|-------|----------|-------|----------|
| 109 | 03:05 | 1 | 01:04 |



Dialogue
 79. CALIMERO (au micro de Mr Kinos)
 Oui, c'est Valériano qui l'a fait ! Et son film s'appelle? « L'INVASION DES CAROTTES GEANTES DE L'ESPACE. »

| Scene | Duration | Panel | Duration |
|-------|----------|-------|----------|
| 109 | 03:05 | 2 | 01:01 |



Action Notes
LUMIERE OFF

| Scene | Duration | Panel | Duration |
|-------|----------|-------|----------|
| 109 | 03:05 | 3 | 01:00 |



| Scene | Duration | Panel | Duration |
|-------|----------|-------|----------|
| 110 | 05:14 | 1 | 01:05 |

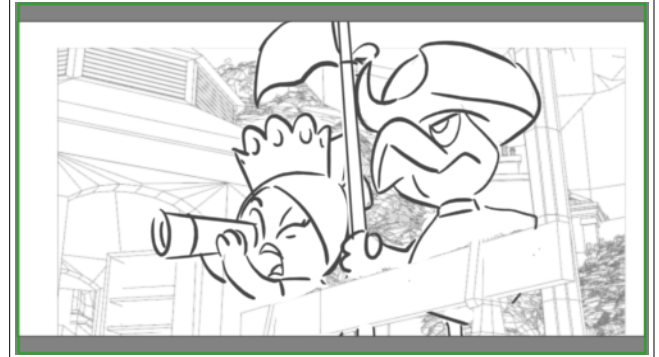

Dialogue
80. MODIF PRISCILLA
Oh non, regardez, capitaine!

| Scene | Duration | Panel | Duration |
|-------|----------|-------|----------|
| 110 | 05:14 | 2 | 01:06 |

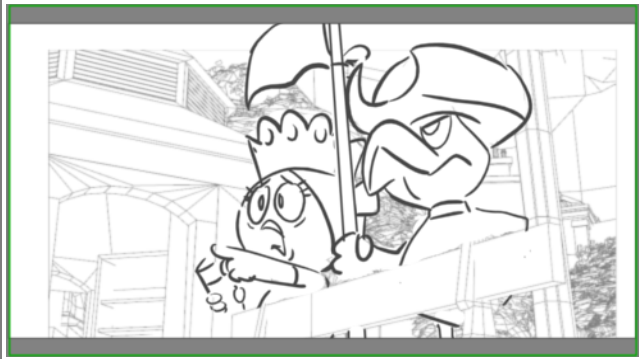

Dialogue

80. MODIF PRISCILLA
Oh non, regardez, capitaine!

| Scene | Duration | Panel | Duration |
|-------|----------|-------|----------|
| 110 | 05:14 | 3 | 01:21 |

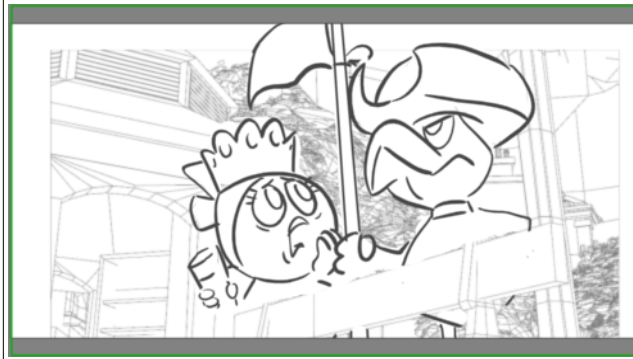

Dialogue

80. MODIF PRISCILLA
Les carottes de l'espace !!!

| Scene | Duration | Panel | Duration |
|-------|----------|-------|----------|
| 110 | 05:14 | 4 | 01:07 |

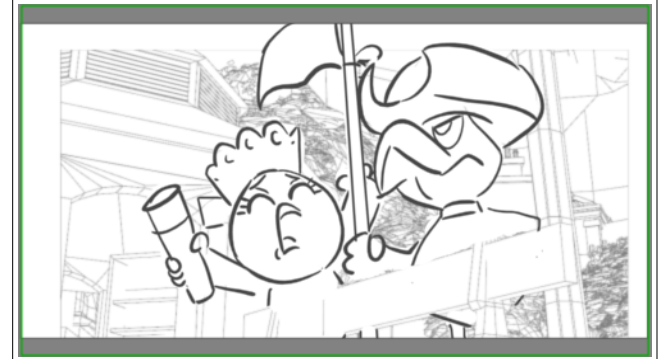

Dialogue

80. MODIF PRISCILLA
Les carottes de l'espace !!!

| Scene | Duration | Panel | Duration |
|-------|----------|-------|----------|
| 111 | 01:21 | 1 | 01:21 |

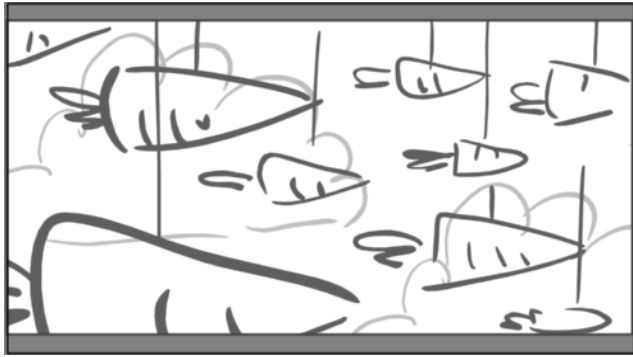

Dialogue

80. MODIF PRISCILLA
Elles nous attaaaaquent !

Action Notes

? PLAN MOULIN 1
Une armada de carottes géantes vole dans le ciel.

| Scene | Duration | Panel | Duration |
|-------|----------|-------|----------|
| 112 | 05:05 | 1 | 00:10 |

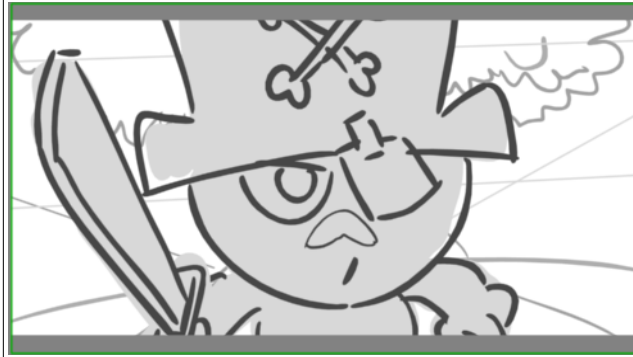

| Scene | Duration | Panel | Duration |
|-------|----------|-------|----------|
| 112 | 05:05 | 2 | 00:09 |

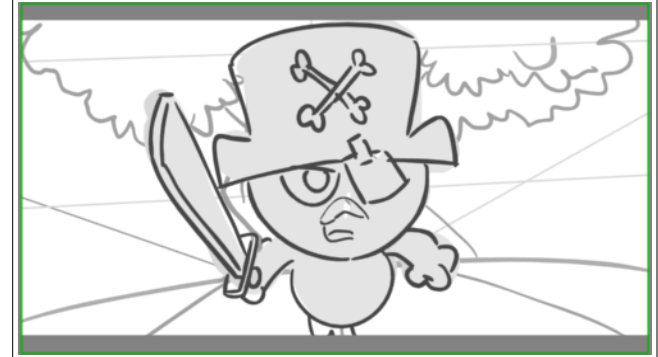

| Scene | Duration | Panel | Duration |
|-------|----------|-------|----------|
| 112 | 05:05 | 3 | 00:11 |



Dialogue

80. MODIF CALIMERO
 C'est vraiment trop injuste ! Aaaaah
 !!!

| Scene | Duration | Panel | Duration |
|-------|----------|-------|----------|
| 112 | 05:05 | 4 | 02:09 |



Dialogue

80. MODIF CALIMERO
 C'est vraiment trop injuste ! Aaaaah
 !!!

| Scene | Duration | Panel | Duration |
|-------|----------|-------|----------|
| 112 | 05:05 | 5 | 01:16 |



Dialogue

80. MODIF CALIMERO
 C'est vraiment trop injuste ! Aaaaah
 !!!

| Scene | Duration | Panel | Duration |
|-------|----------|-------|----------|
| 113 | 09:10 | 1 | 01:17 |

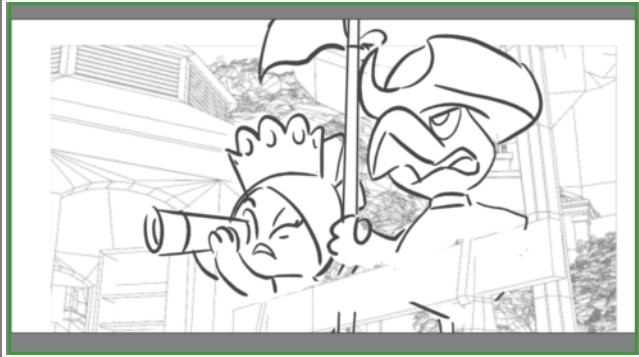

Dialogue

81. MODIF PIERROT
C'est horrible !

| Scene | Duration | Panel | Duration |
|-------|----------|-------|----------|
| 113 | 09:10 | 2 | 03:04 |

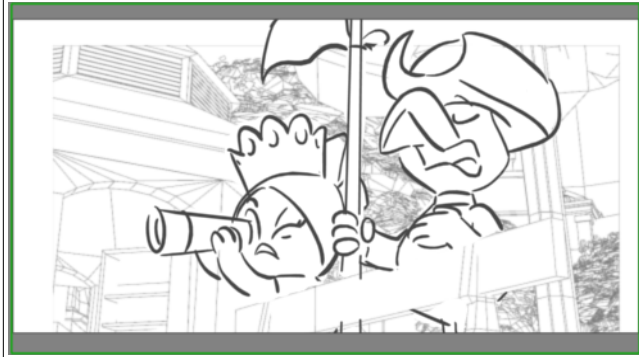

Dialogue

81. MODIF PIERROT
Elles s'en prennent même aux lapins !

| Scene | Duration | Panel | Duration |
|-------|----------|-------|----------|
| 113 | 09:10 | 3 | 01:00 |

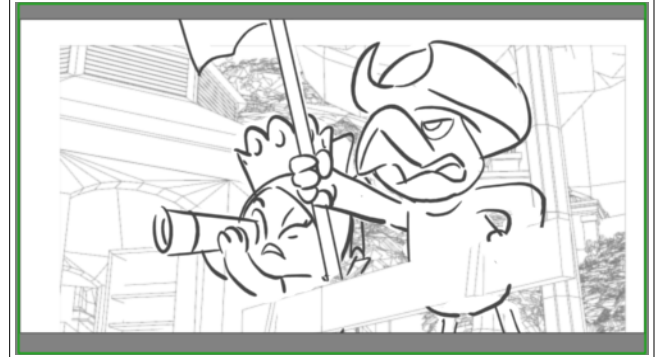

Dialogue

81. MODIF PIERROT
Fuyez les amis !

| Scene | Duration | Panel | Duration |
|-------|----------|-------|----------|
| 113 | 09:10 | 4 | 01:00 |

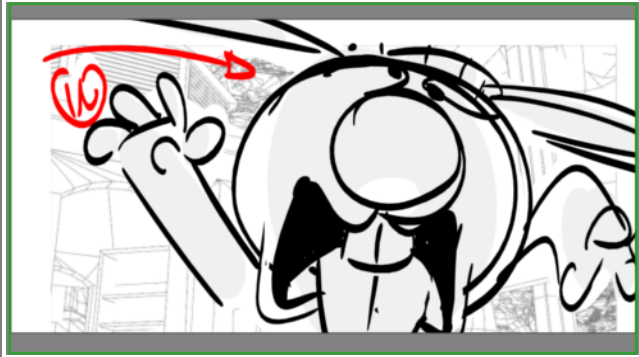

Dialogue

82. POT (tirant la langue)
Bleuaaarrrrr !

| Scene | Duration | Panel | Duration |
|-------|----------|-------|----------|
| 113 | 09:10 | 5 | 00:14 |

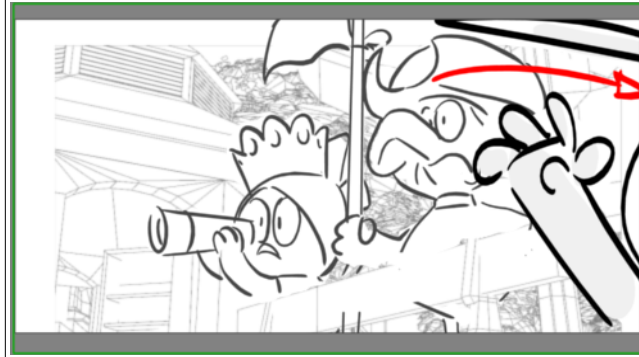

Dialogue

25. POT (tirant la langue et feignant la peur)
J'ai trop peurrrrrrrr !

| Scene | Duration | Panel | Duration |
|-------|----------|-------|----------|
| 113 | 09:10 | 6 | 00:08 |

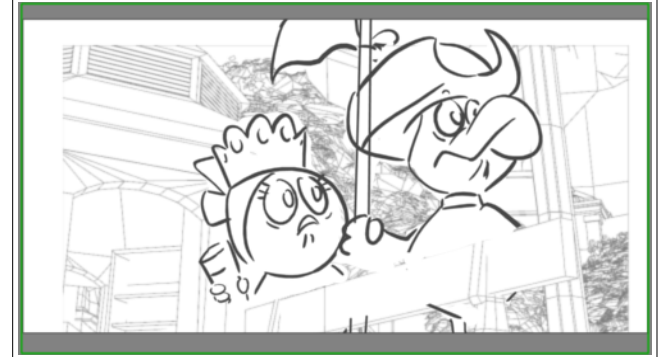

Dialogue

25. POT (tirant la langue et feignant la peur)
J'ai trop peurrrrrrrr !

| Scene | Duration | Panel | Duration |
|-------|----------|-------|----------|
| 113 | 09:10 | 7 | 00:17 |

| Scene | Duration | Panel | Duration |
|-------|----------|-------|----------|
| 113 | 09:10 | 8 | 01:00 |

NO PANEL

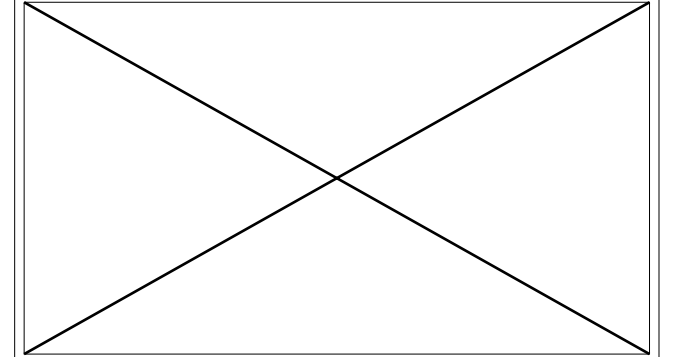
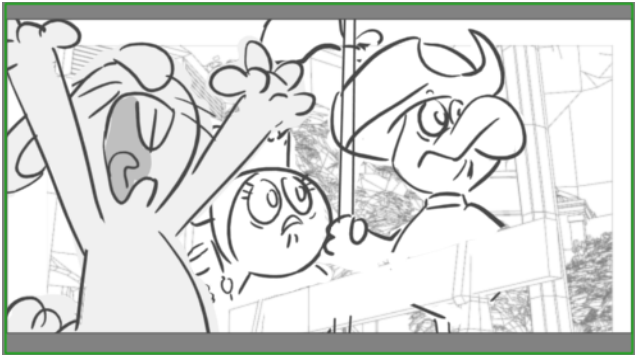

Dialogue
 25. POT (tirant la langue et feignant la peur)
 J'ai trop peurrrrrrrr !

Dialogue
 25. POT (tirant la langue et feignant la peur)
 J'ai trop peurrrrrrrr !



| | | | |
|-------|----------|-------|----------|
| Scene | Duration | Panel | Duration |
| 114 | 07:01 | 1 | 01:01 |

NO PANEL

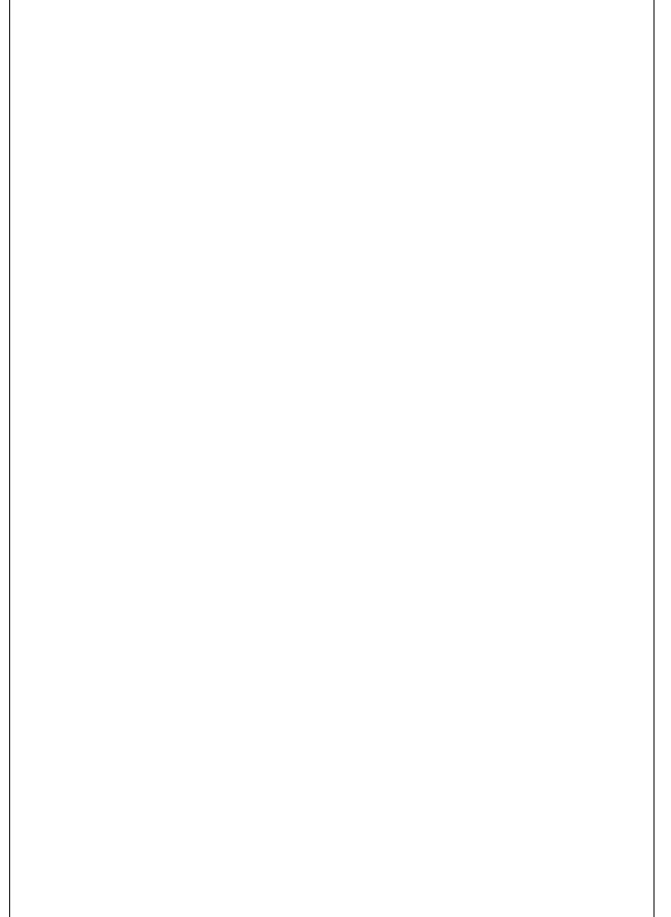
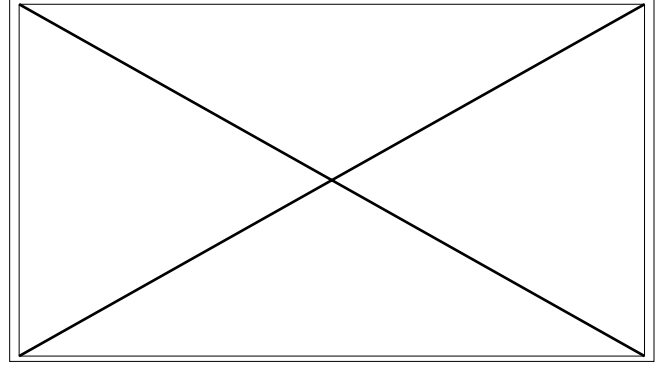
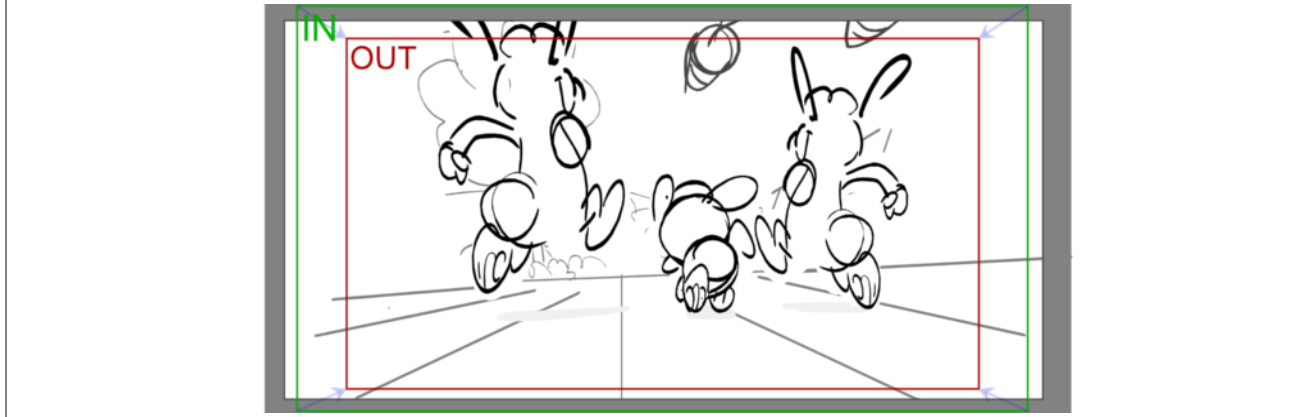



| | | | |
|-------|----------|-------|----------|
| Scene | Duration | Panel | Duration |
| 114 | 07:01 | 2 | 01:07 |

NO PANEL

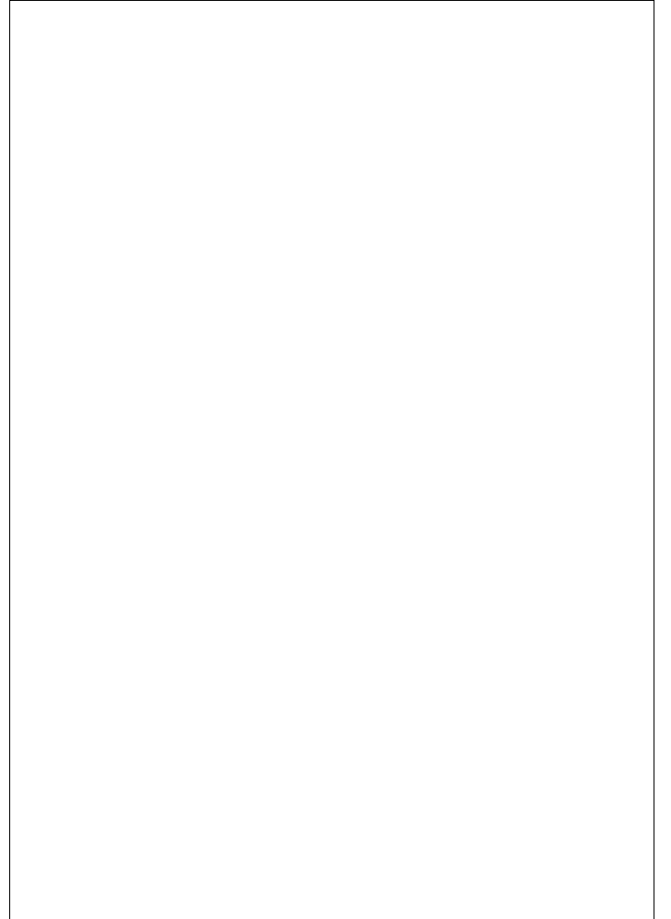
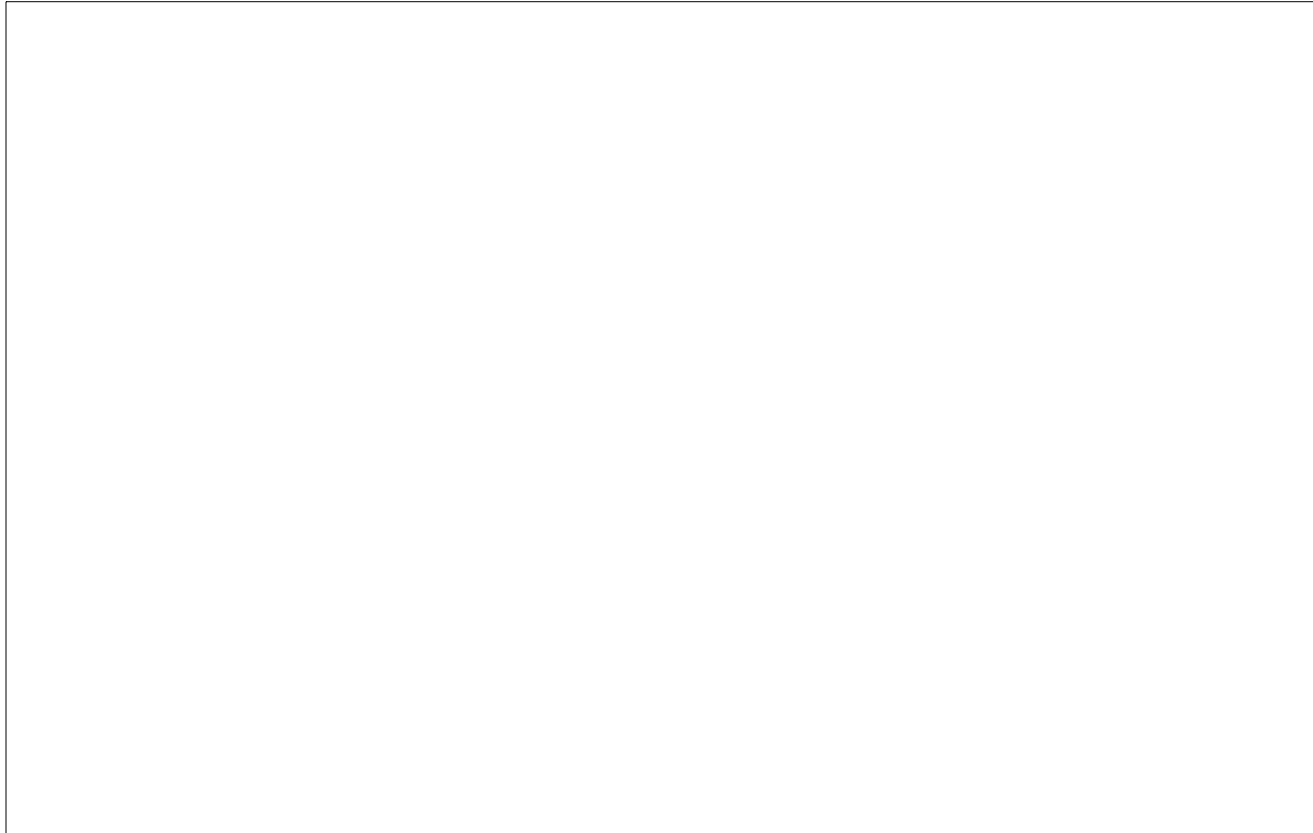
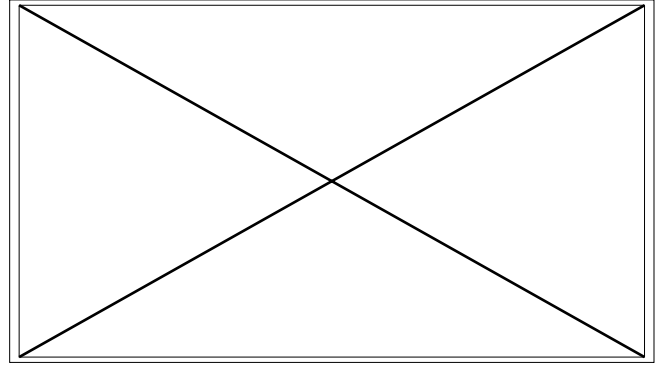
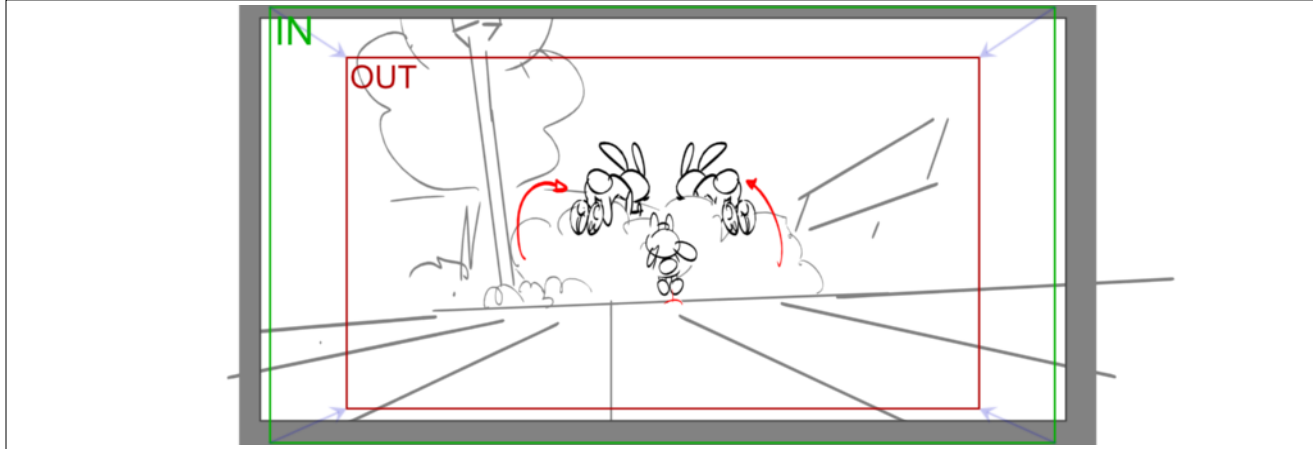



| | | | |
|-------|----------|-------|----------|
| Scene | Duration | Panel | Duration |
| 114 | 07:01 | 3 | 00:16 |

NO PANEL

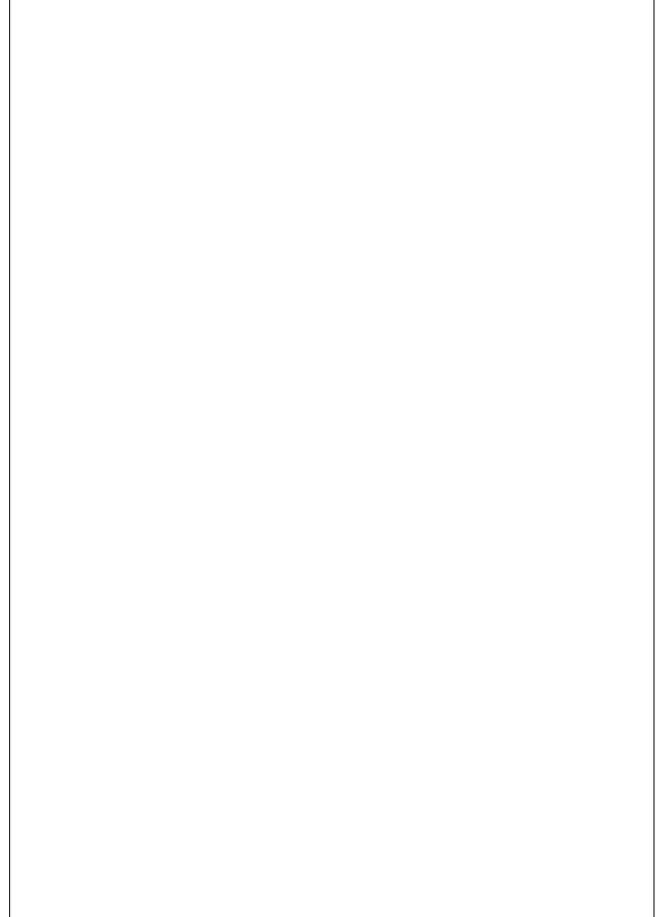
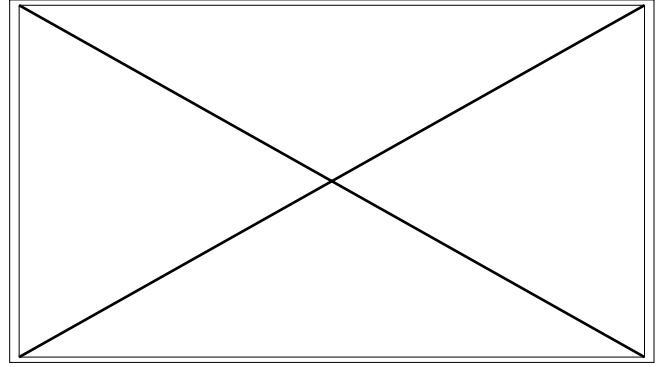
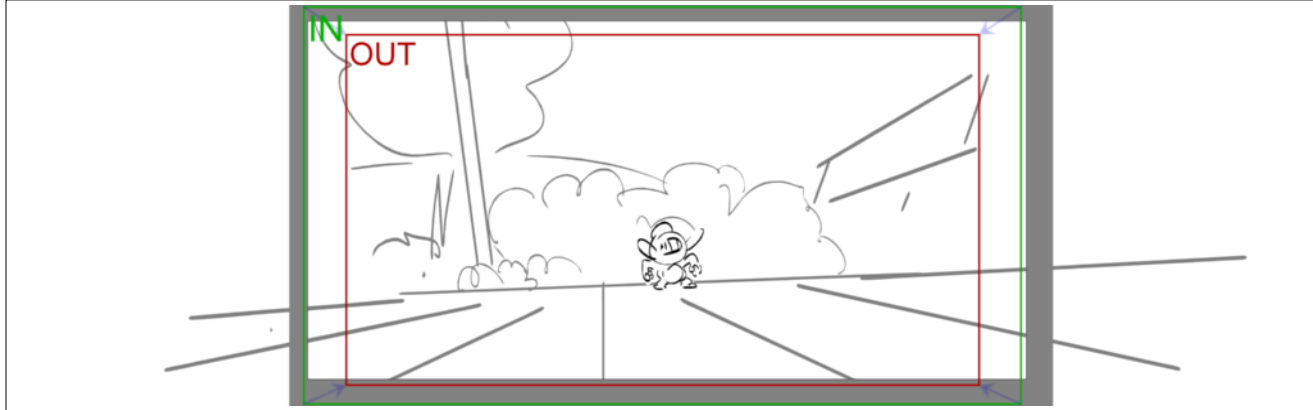



| | | | |
|-------|----------|-------|----------|
| Scene | Duration | Panel | Duration |
| 114 | 07:01 | 4 | 00:21 |

NO PANEL

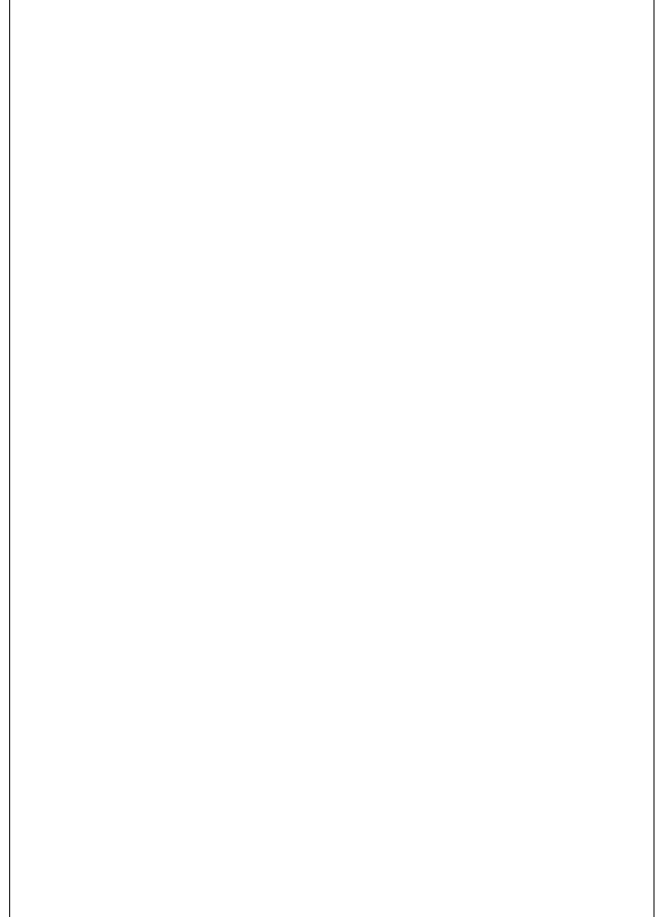
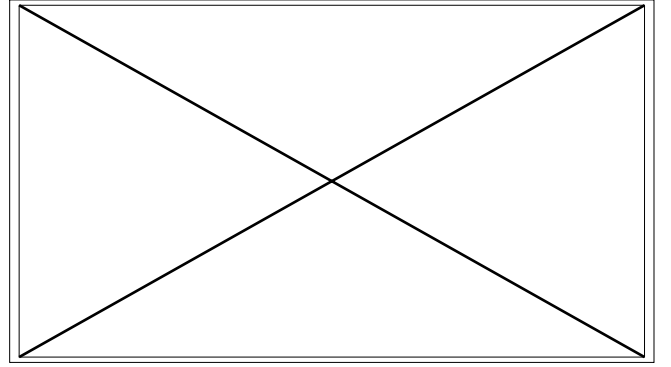
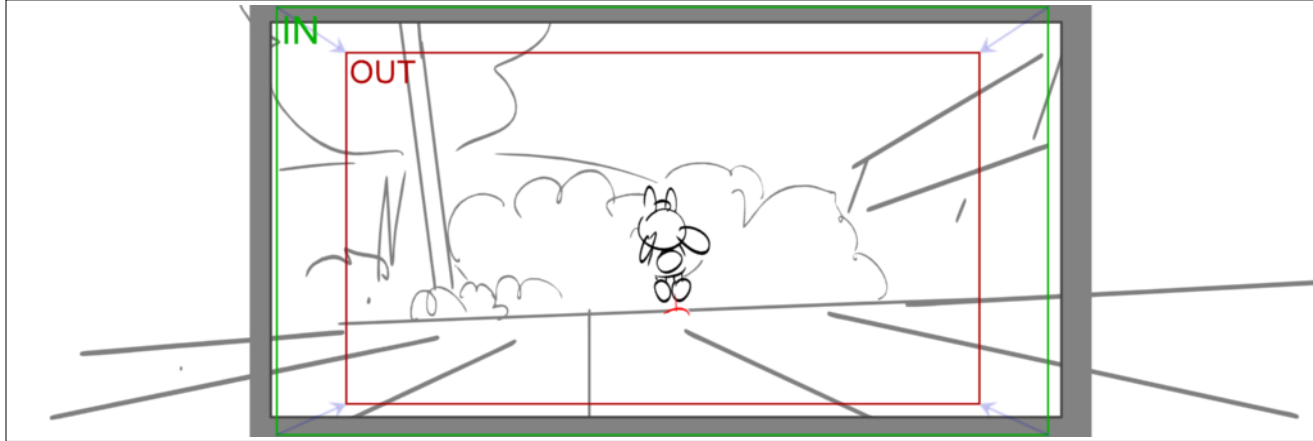



| | | | |
|-------|----------|-------|----------|
| Scene | Duration | Panel | Duration |
| 114 | 07:01 | 5 | 00:21 |

NO PANEL

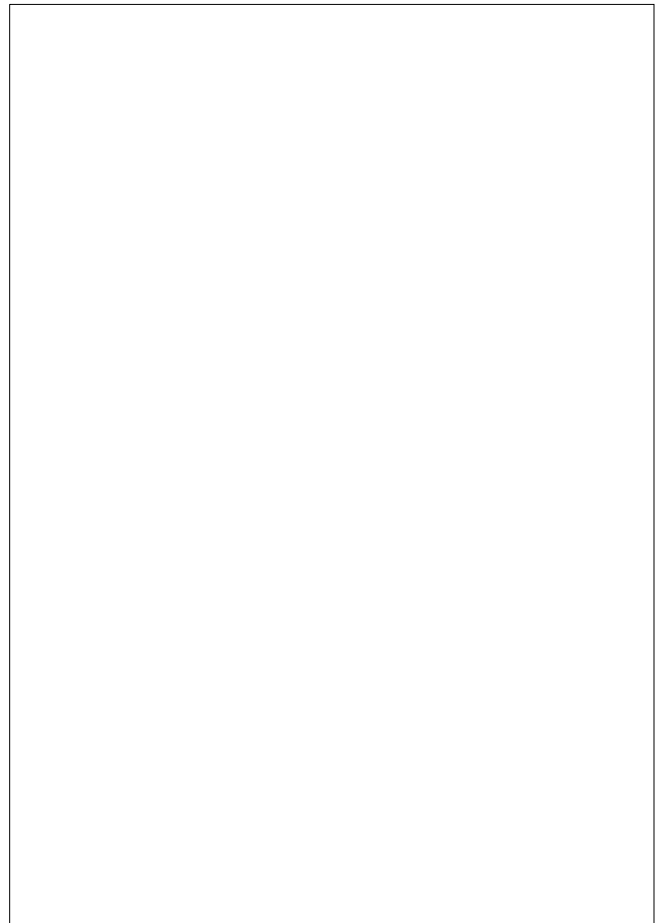
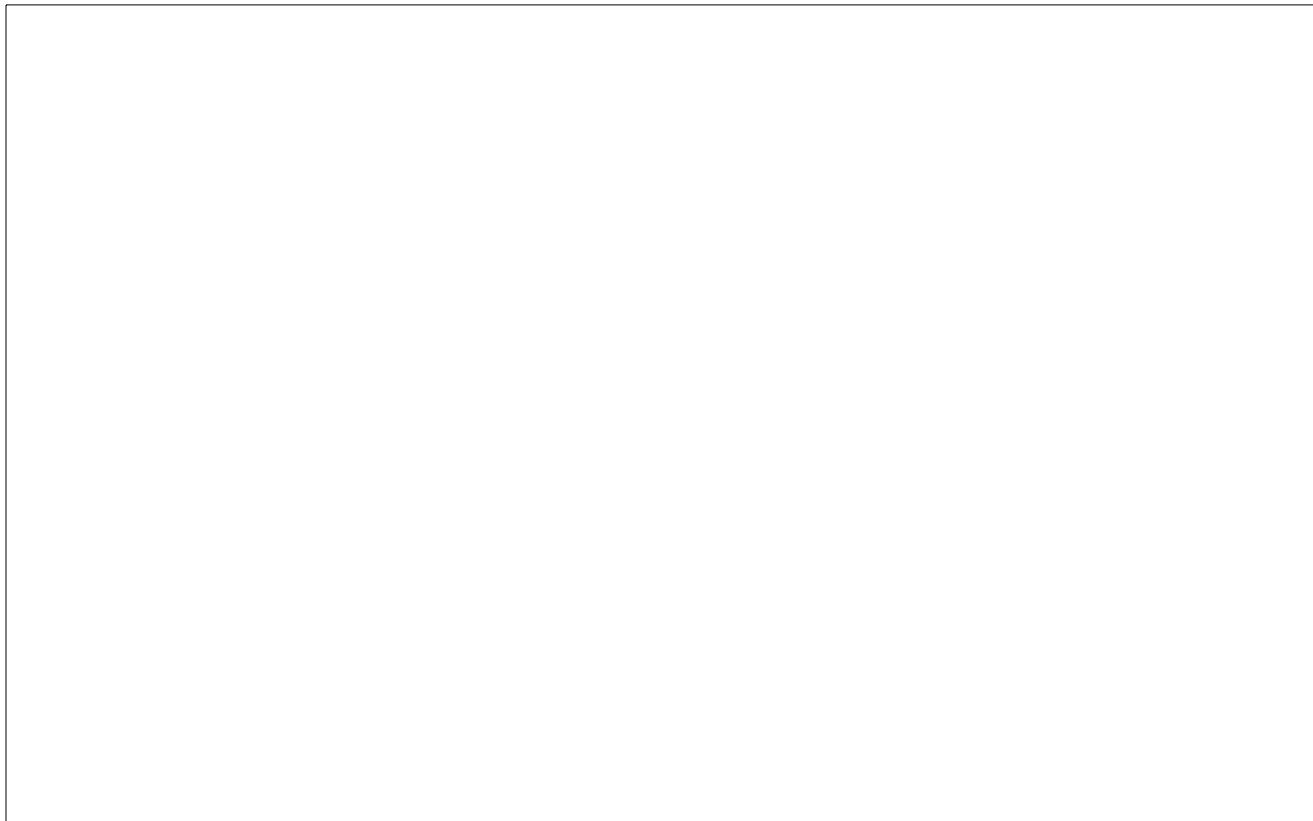
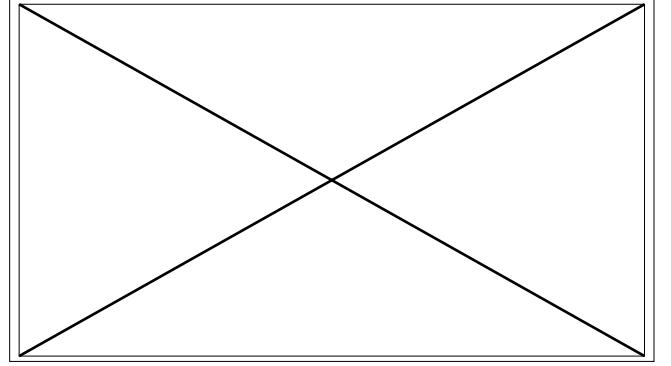
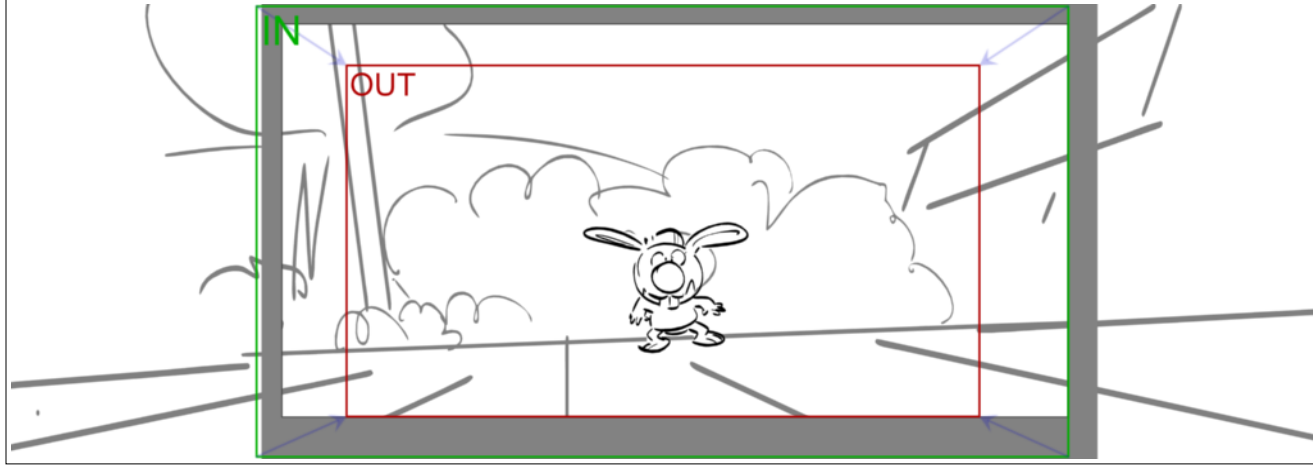



| | | | |
|-------|----------|-------|----------|
| Scene | Duration | Panel | Duration |
| 114 | 07:01 | 6 | 00:21 |

NO PANEL

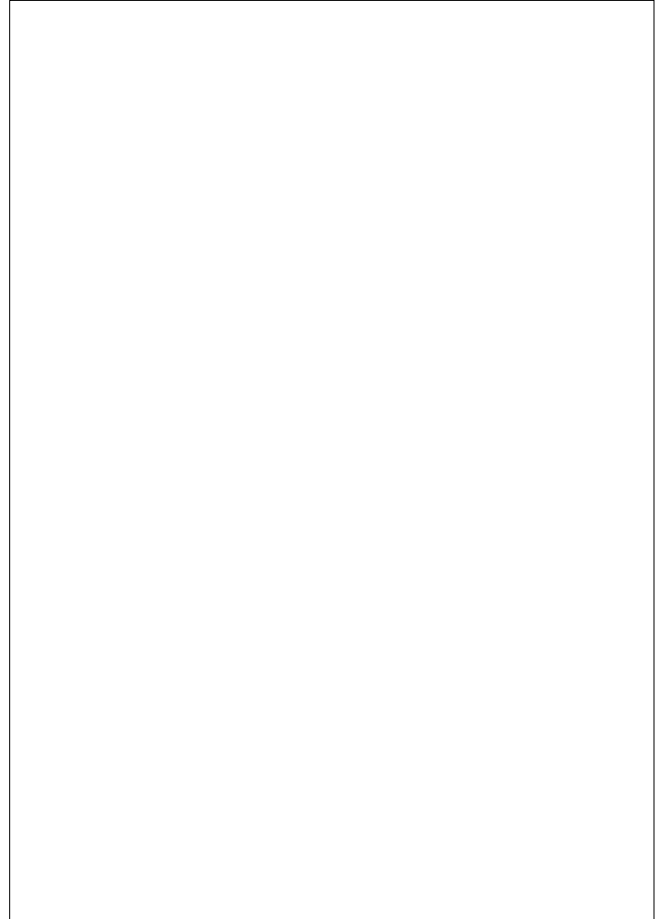
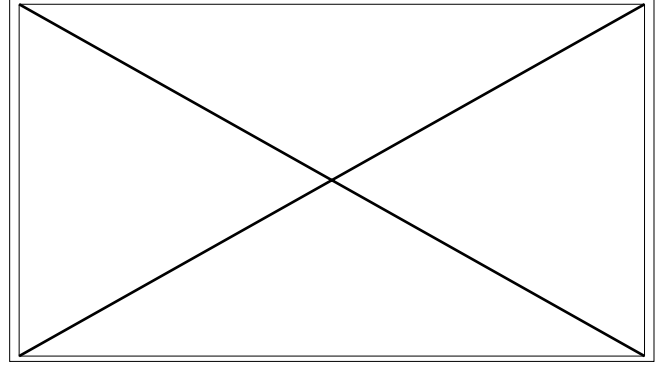
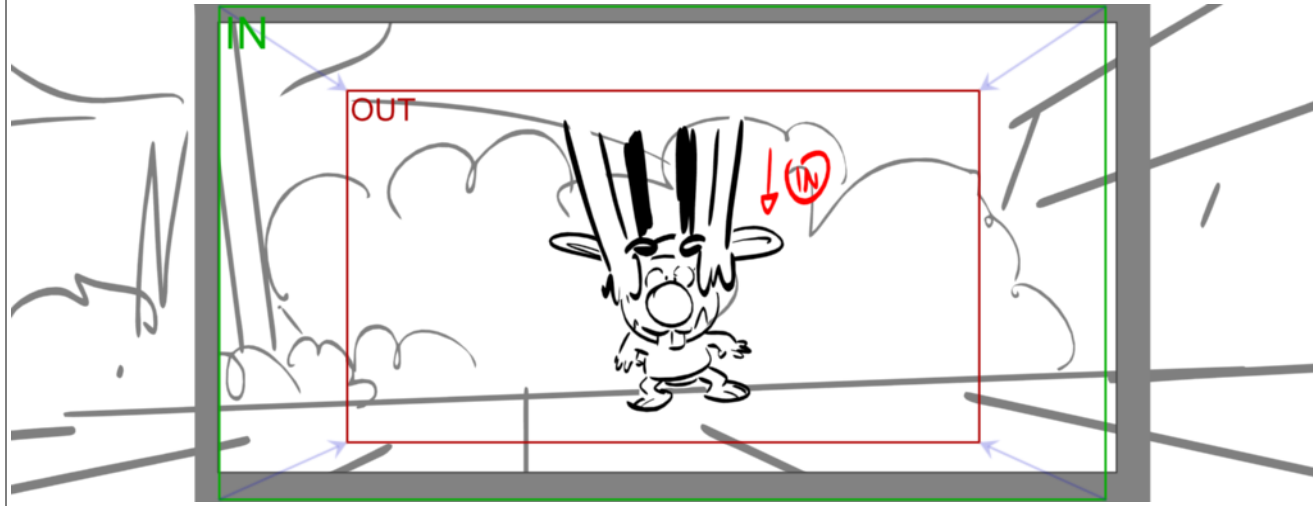



| Scene | Duration | Panel | Duration |
|-------|----------|-------|----------|
| 114 | 07:01 | 7 | 00:21 |

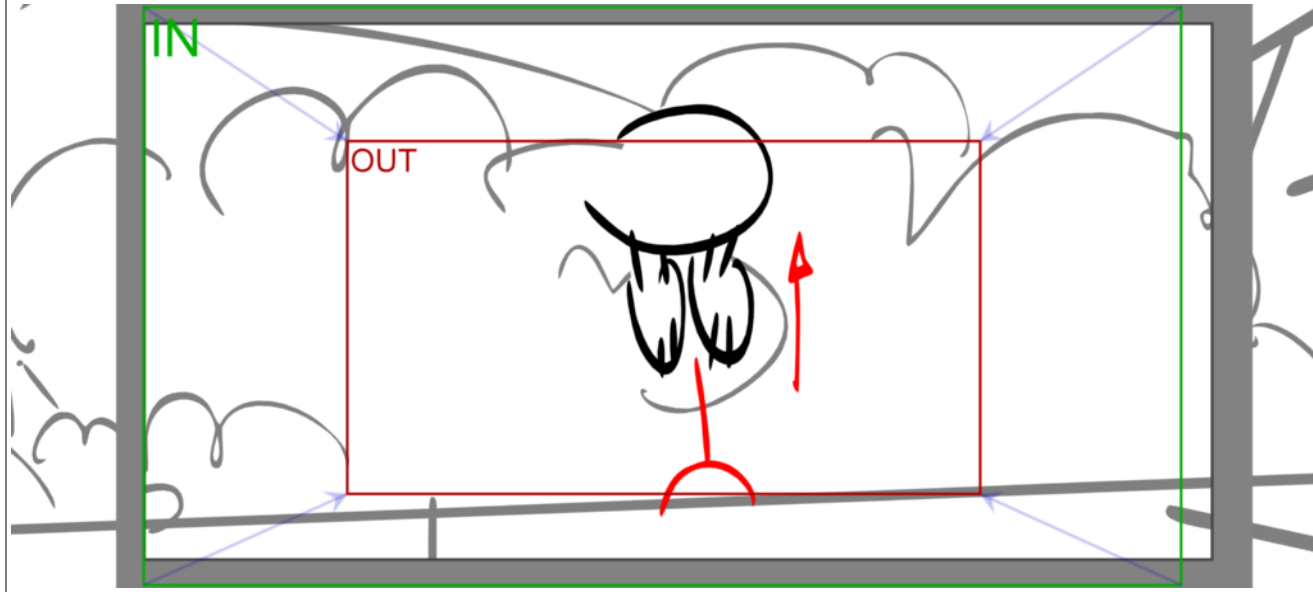

| Scene | Duration | Panel | Duration |
|-------|----------|-------|----------|
| 114 | 07:01 | 8 | 00:18 |

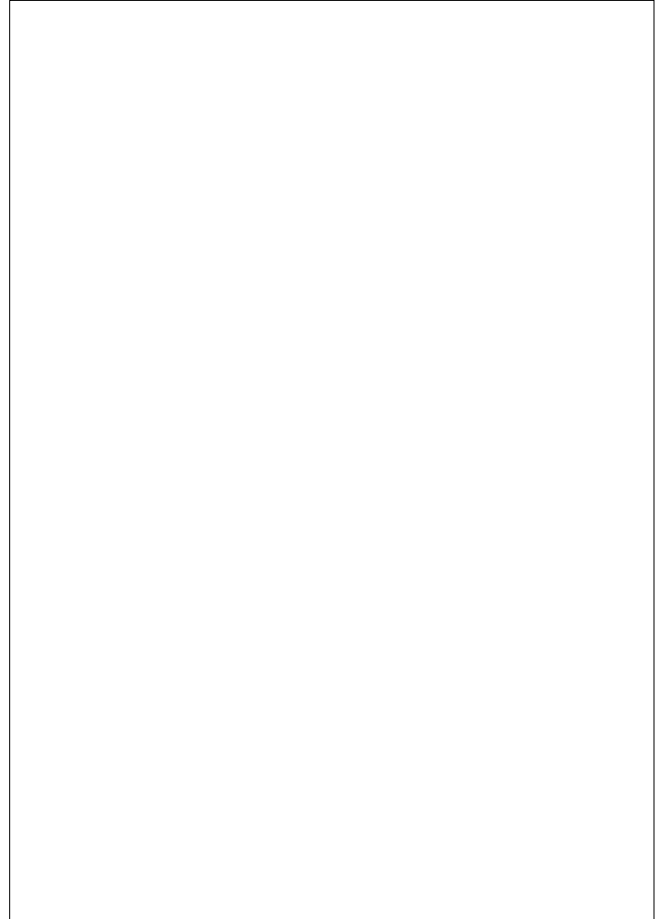
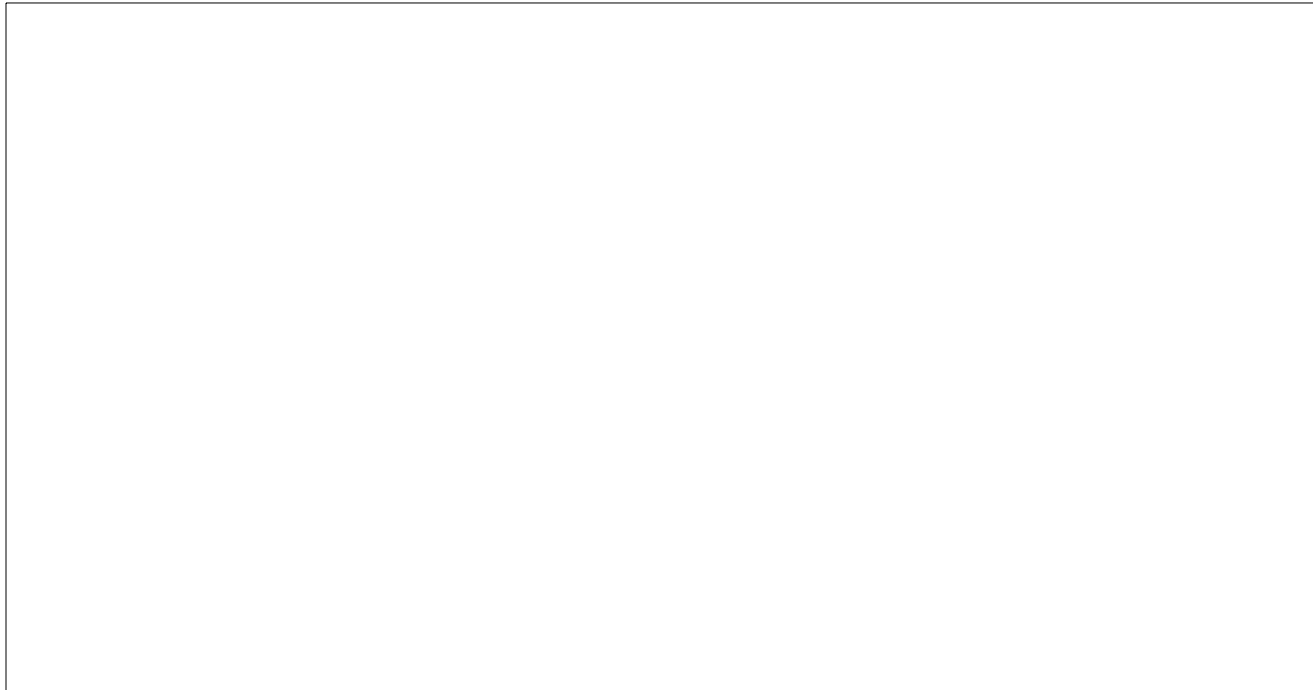



| Scene | Duration | Panel | Duration |
|-------|----------|-------|----------|
| 115 | 01:08 | 1 | 00:05 |

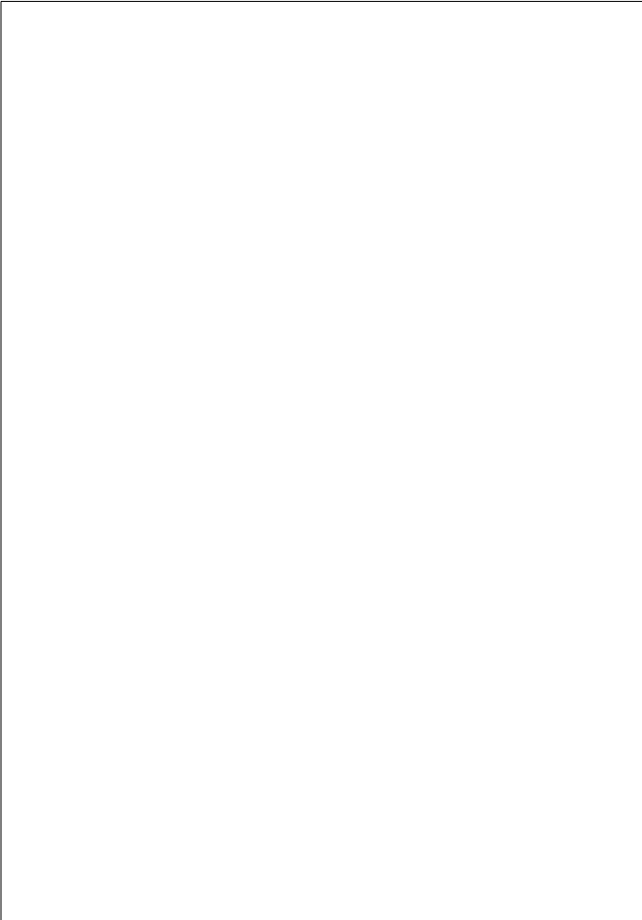

| Scene | Duration | Panel | Duration |
|-------|----------|-------|----------|
| 115 | 01:08 | 2 | 00:08 |

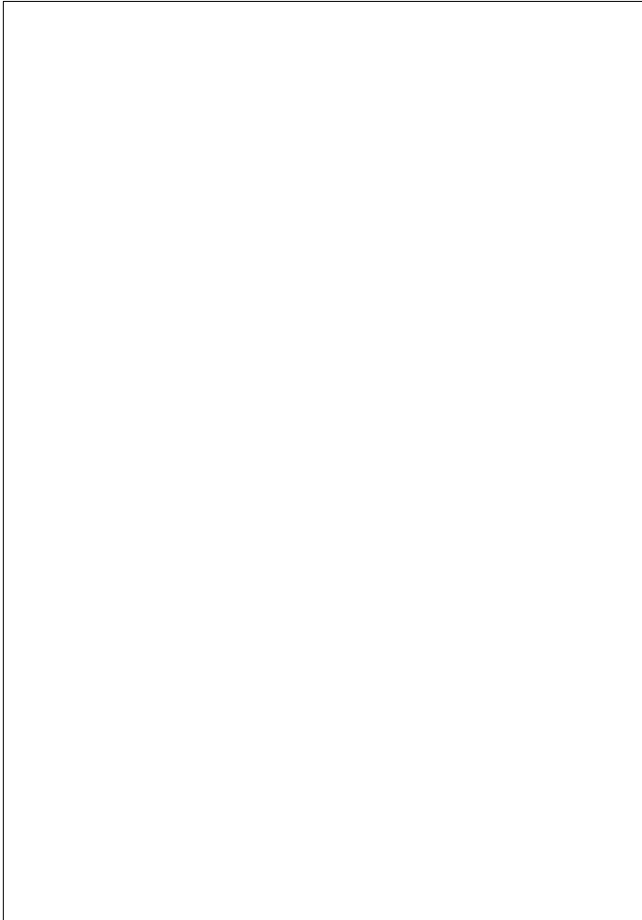

| Scene | Duration | Panel | Duration |
|-------|----------|-------|----------|
| 115 | 01:08 | 3 | 00:07 |

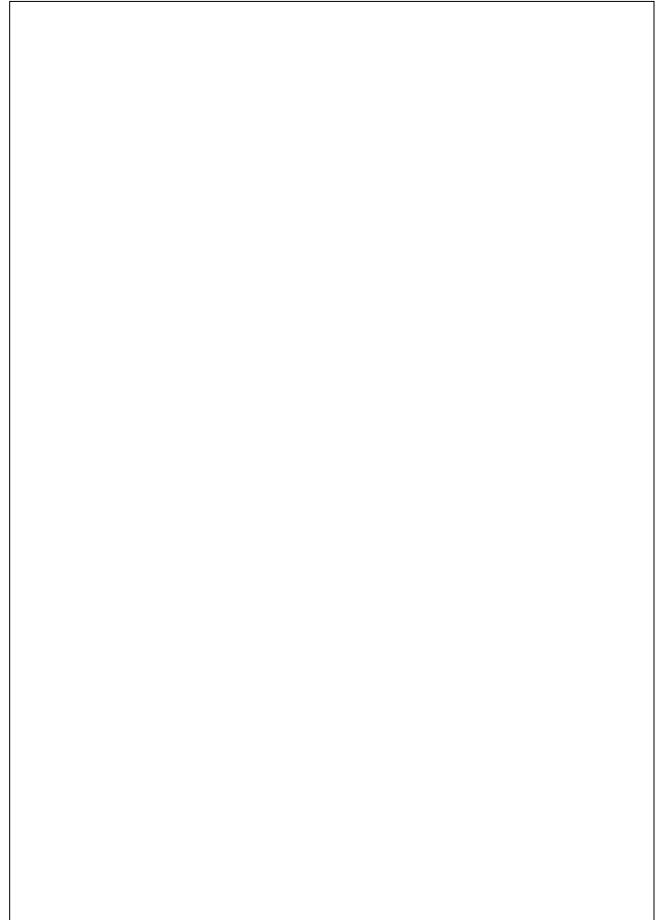



| Scene | Duration | Panel | Duration |
|-------|----------|-------|----------|
| 115 | 01:08 | 4 | 00:08 |



| Scene | Duration | Panel | Duration |
|-------|----------|-------|----------|
| 115 | 01:08 | 5 | 00:05 |



| Scene | Duration | Panel | Duration |
|-------|----------|-------|----------|
| 116 | 03:08 | 1 | 00:12 |



Dialogue

SFX LAPINET

Aie aie ouille!!!

| Scene | Duration | Panel | Duration |
|-------|----------|-------|----------|
| 116 | 03:08 | 2 | 02:21 |



Dialogue

84. PUBLIC
<Rires>

| Scene | Duration | Panel | Duration |
|-------|----------|-------|----------|
| 117 | 03:06 | 1 | 01:06 |

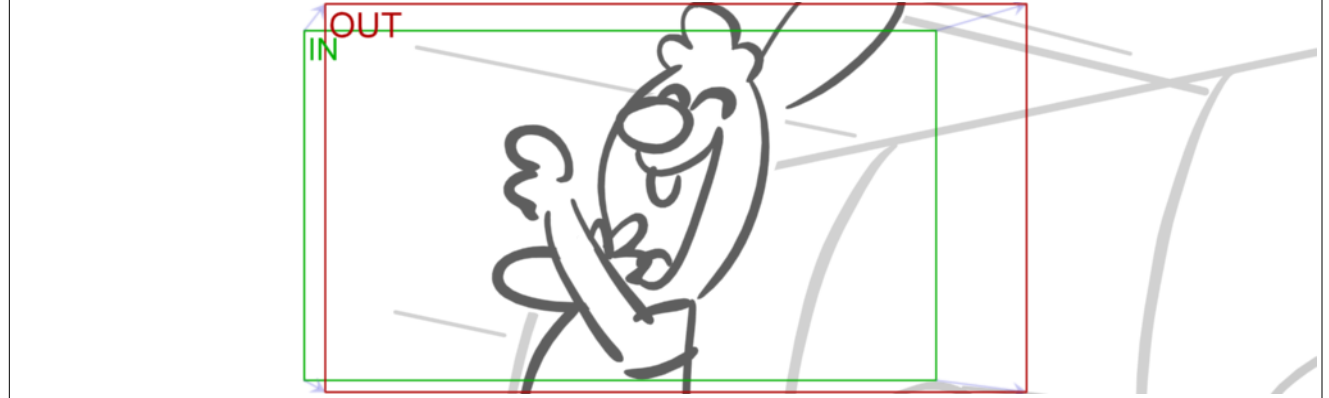

Dialogue

PICK UP MOT
Arf arf arf!

| Scene | Duration | Panel | Duration |
|-------|----------|-------|----------|
| 117 | 03:06 | 2 | 01:00 |

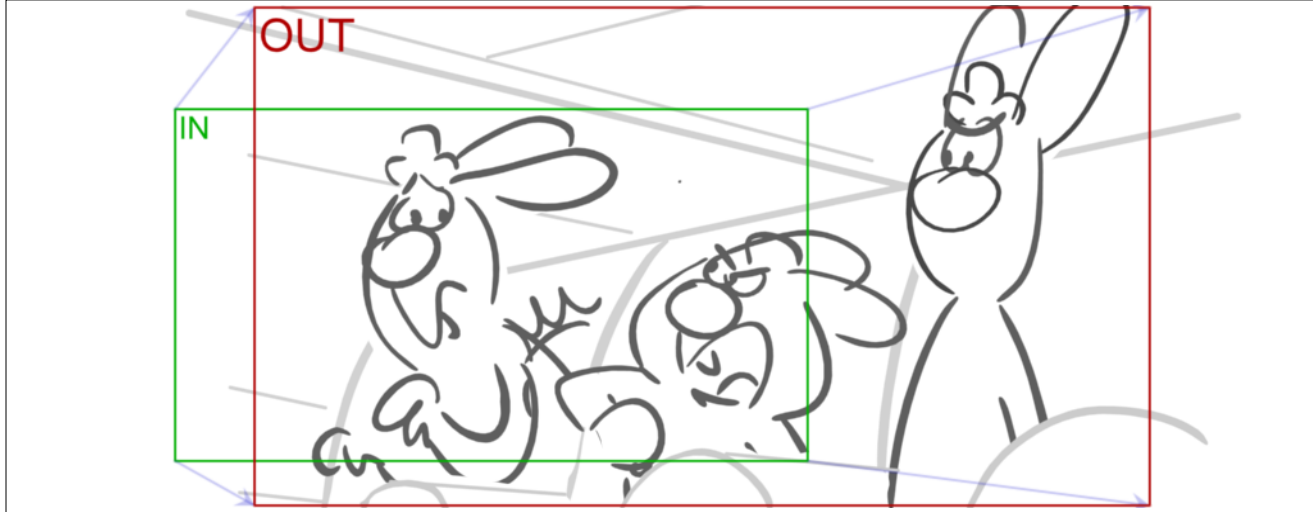

Dialogue
 PICK UP POT
 Arrête de rire imbécile!

| Scene | Duration | Panel | Duration |
|-------|----------|-------|----------|
| 117 | 03:06 | 3 | 01:00 |



Dialogue
 PICK UP PRISCILLA OFF
 regardez ce qui arrive capitaine!

| Scene | Duration | Panel | Duration |
|-------|----------|-------|----------|
| 118 | 02:00 | 1 | 01:00 |

| Scene | Duration | Panel | Duration |
|-------|----------|-------|----------|
| 118 | 02:00 | 2 | 01:00 |

| Scene | Duration | Panel | Duration |
|-------|----------|-------|----------|
| 119 | 02:00 | 1 | 01:00 |

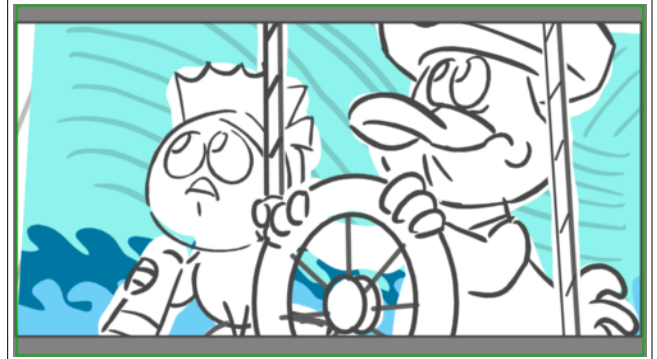
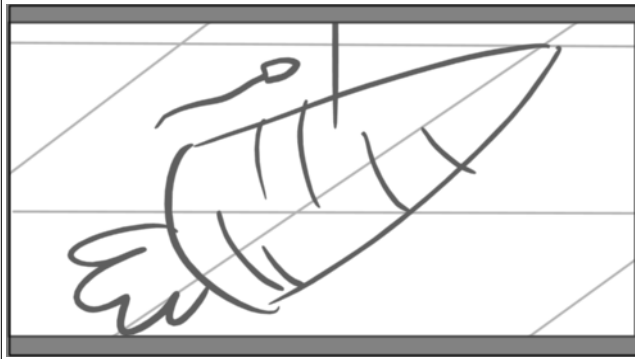
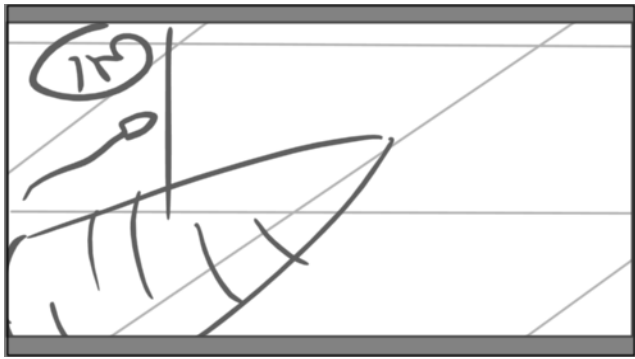

Dialogue
 PICK UP
 La reine des carottes!

| Scene | Duration | Panel | Duration |
|-------|----------|-------|----------|
| 119 | 02:00 | 2 | 01:00 |

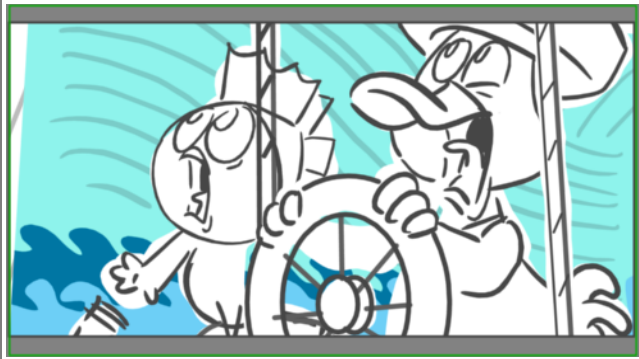

Dialogue
Ahhhh!!

| Scene | Duration | Panel | Duration |
|-------|----------|-------|----------|
| 120 | 02:00 | 1 | 01:00 |

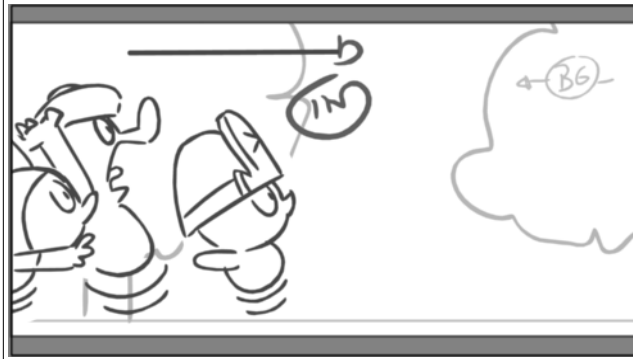

Dialogue
Au secours!!!!

| Scene | Duration | Panel | Duration |
|-------|----------|-------|----------|
| 120 | 02:00 | 2 | 01:00 |

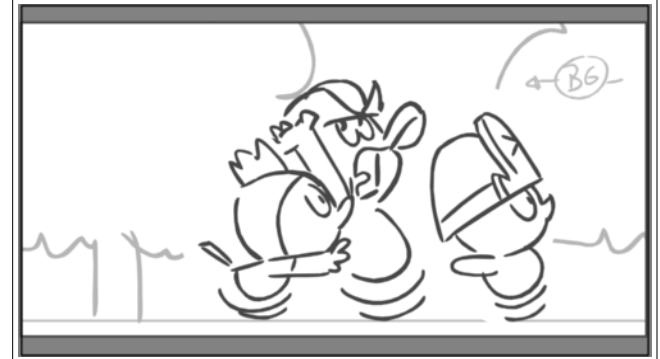

| Scene | Duration | Panel | Duration |
|-------|----------|-------|----------|
| 121 | 01:00 | 1 | 01:00 |

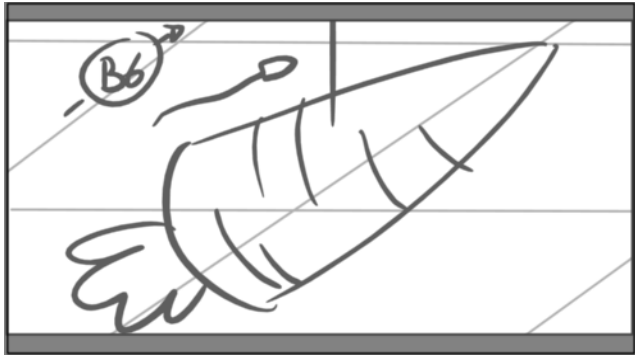

| Scene | Duration | Panel | Duration |
|-------|----------|-------|----------|
| 122 | 02:00 | 1 | 01:00 |

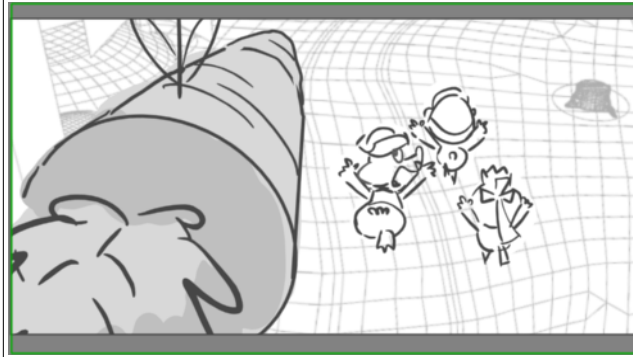

| Scene | Duration | Panel | Duration |
|-------|----------|-------|----------|
| 122 | 02:00 | 2 | 00:10 |

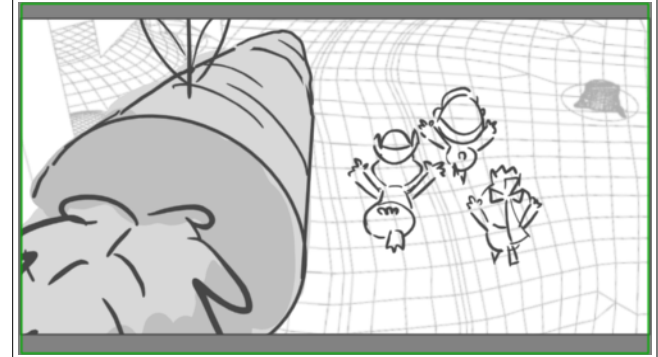

| Scene | Duration | Panel | Duration |
|-------|----------|-------|----------|
| 122 | 02:00 | 3 | 00:15 |

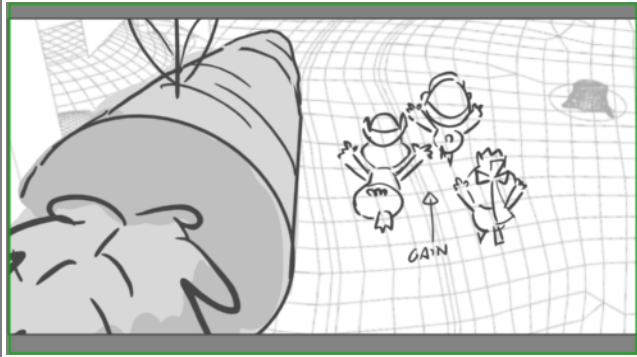

| Scene | Duration | Panel | Duration |
|-------|----------|-------|----------|
| 123 | 04:02 | 1 | 01:00 |

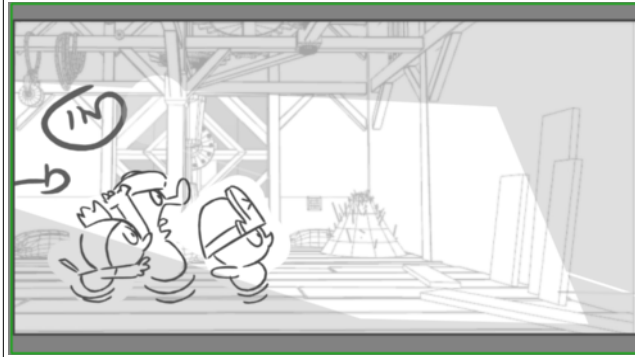

| Scene | Duration | Panel | Duration |
|-------|----------|-------|----------|
| 123 | 04:02 | 2 | 01:00 |

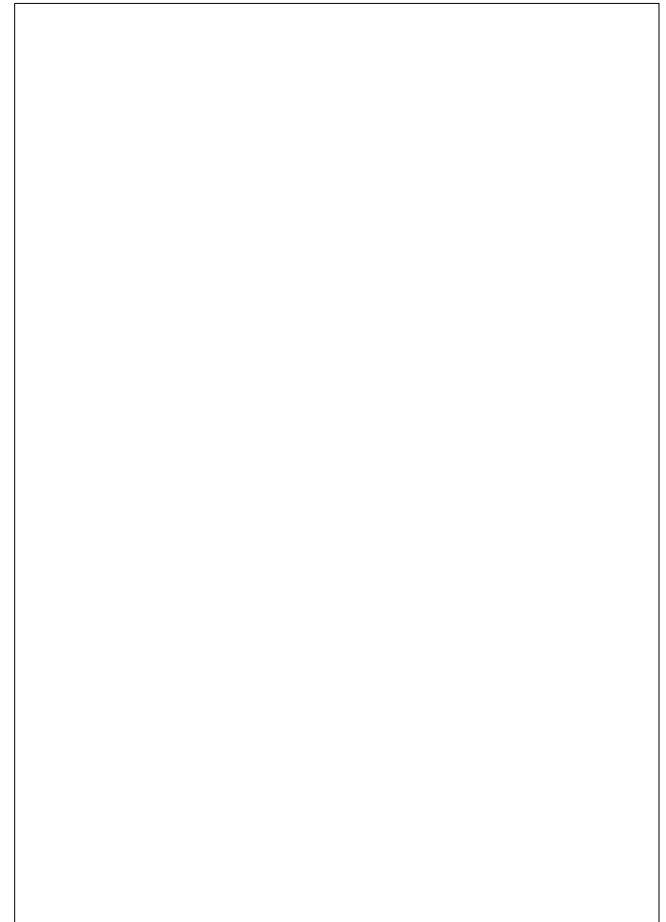
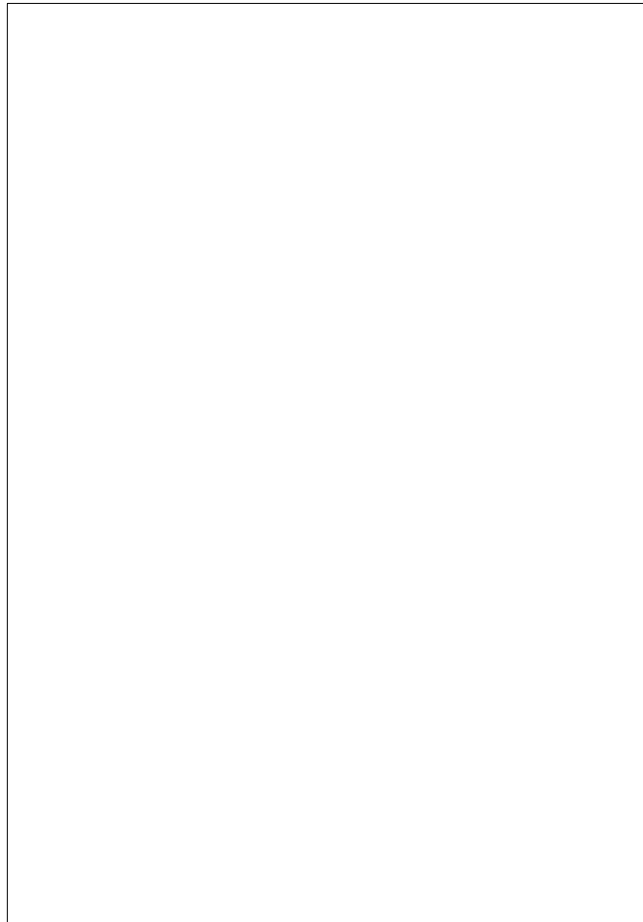
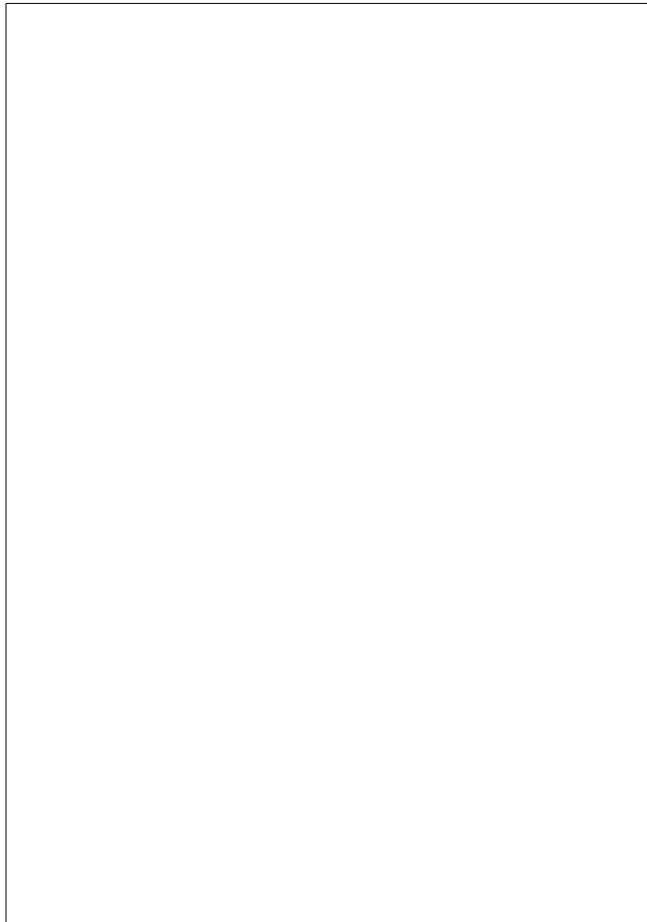
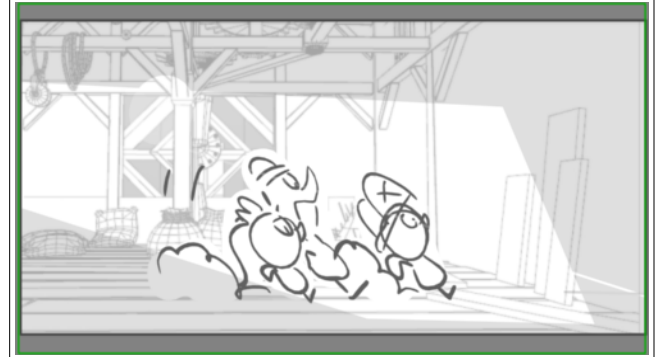

| Scene | Duration | Panel | Duration |
|-------|----------|-------|----------|
| 123 | 04:02 | 3 | 02:02 |

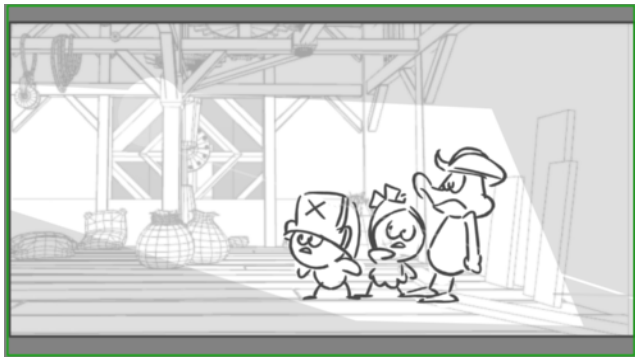

Dialogue

85. CALIMERO (affolé)
Il n'y a plus d'issue !

Action Notes

? PLAN MOULIN 3-C (travelling latéral)
?Caliméro, Pierrot et Priscilla se retrouvent acculés contre un mur.

| Scene | Duration | Panel | Duration |
|-------|----------|-------|----------|
| 124 | 01:12 | 1 | 00:12 |

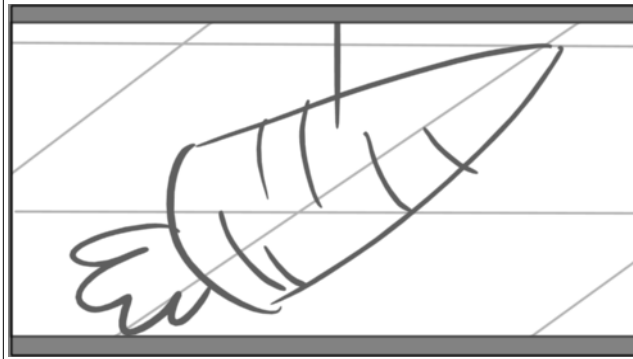

| Scene | Duration | Panel | Duration |
|-------|----------|-------|----------|
| 124 | 01:12 | 2 | 01:00 |

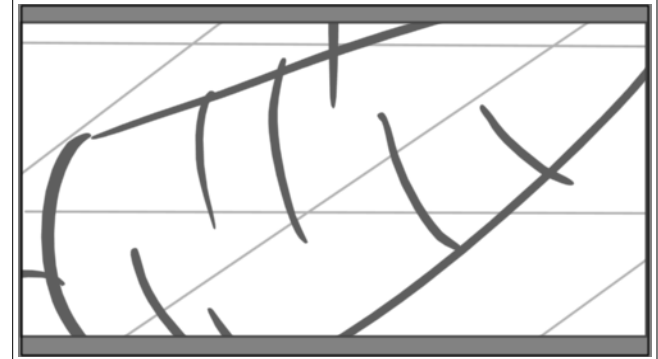

| Scene | Duration | Panel | Duration |
|-------|----------|-------|----------|
| 125 | 02:05 | 1 | 01:05 |

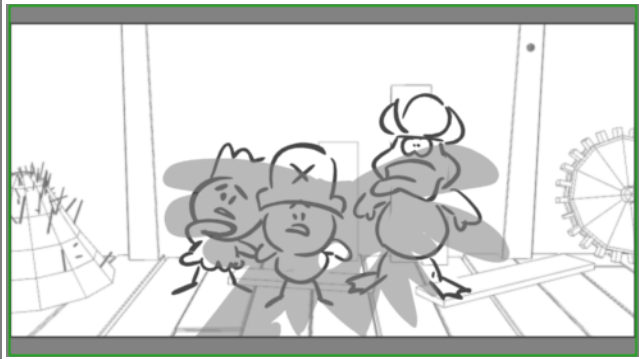

Dialogue

85. CALIMERO (affolé)
C'est la finnnn !

| Scene | Duration | Panel | Duration |
|-------|----------|-------|----------|
| 125 | 02:05 | 2 | 01:00 |

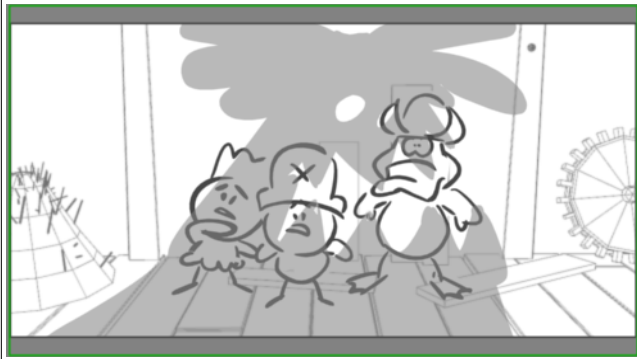

| Scene | Duration | Panel | Duration |
|-------|----------|-------|----------|
| 126 | 03:11 | 1 | 01:18 |

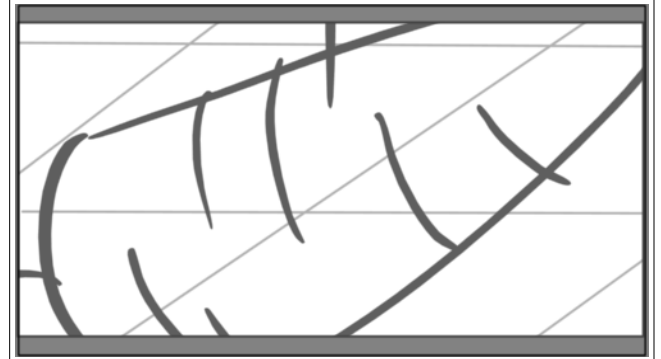

Dialogue

86. PRISCILLA (affolée)
Il n'y a vraiment personne pour nous sauver ?!

| Scene | Duration | Panel | Duration |
|-------|----------|-------|----------|
| 126 | 03:11 | 2 | 01:18 |

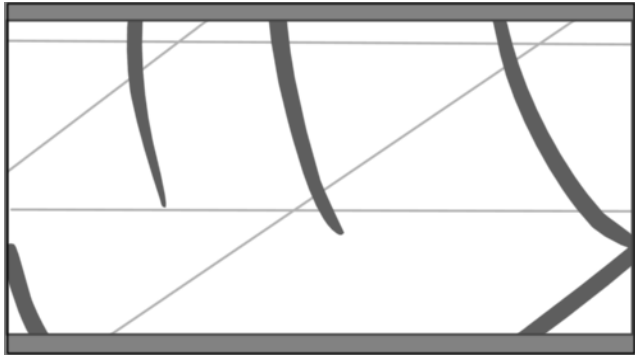

| Scene | Duration | Panel | Duration |
|-------|----------|-------|----------|
| 127 | 05:05 | 1 | 01:00 |

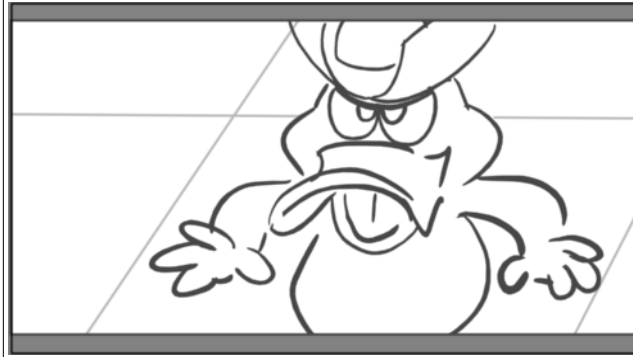

| Scene | Duration | Panel | Duration |
|-------|----------|-------|----------|
| 127 | 05:05 | 2 | 00:18 |



Dialogue

87. PIERROT (héroïque)
Z'inquiétez-pas !

| Scene | Duration | Panel | Duration |
|-------|----------|-------|----------|
| 127 | 05:05 | 3 | 01:22 |

| Scene | Duration | Panel | Duration |
|-------|----------|-------|----------|
| 127 | 05:05 | 4 | 01:00 |



Dialogue

87. PIERROT (héroïque)
! J'ai ce qu'il faut !

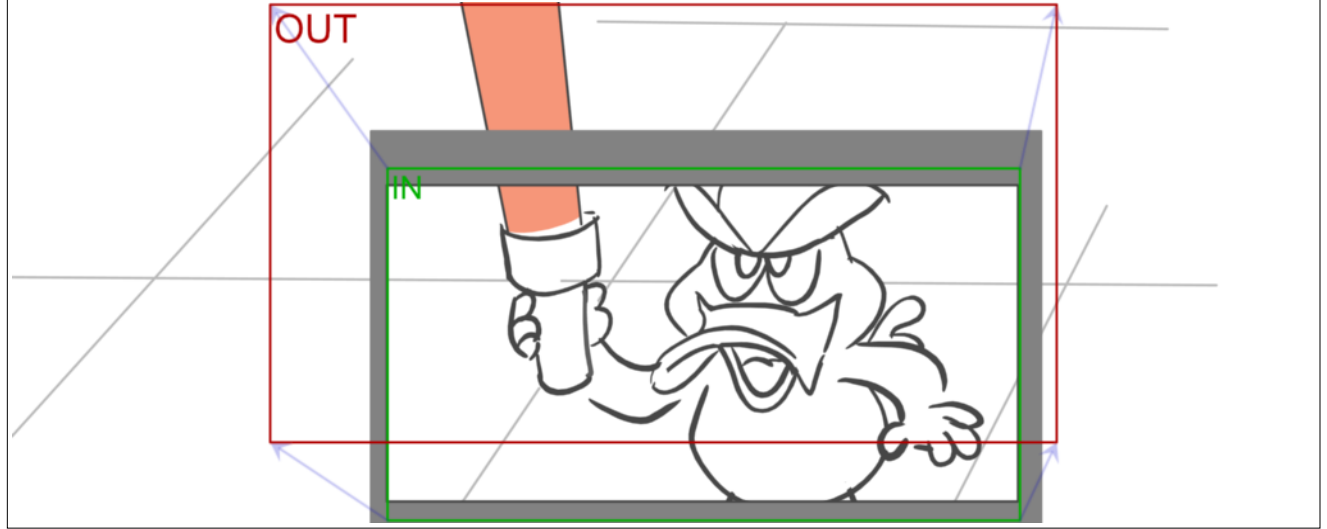

Dialogue

87. PIERROT (héroïque)
Tadaaa !

| Scene | Duration | Panel | Duration |
|-------|----------|-------|----------|
| 127 | 05:05 | 5 | 00:15 |

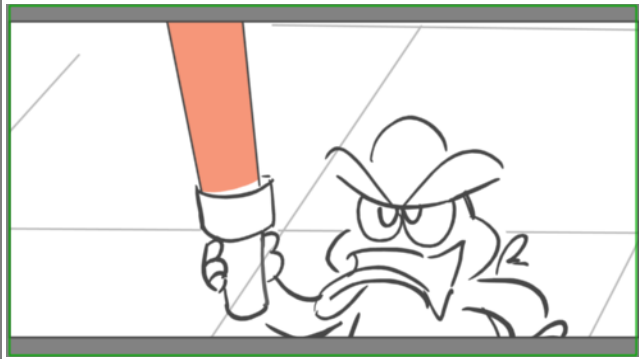

| Scene | Duration | Panel | Duration |
|-------|----------|-------|----------|
| 128 | 04:10 | 1 | 00:09 |

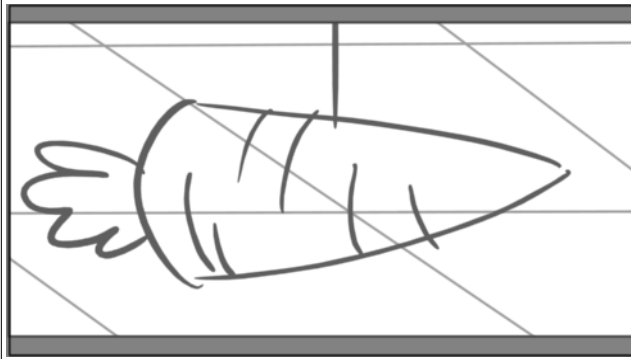

| Scene | Duration | Panel | Duration |
|-------|----------|-------|----------|
| 128 | 04:10 | 2 | 00:09 |

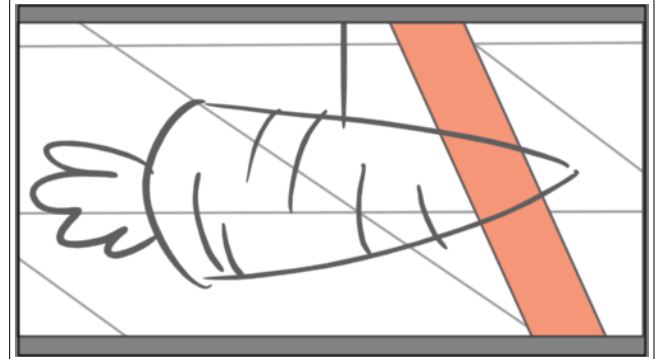

Dialogue

87. PIERROT (héroïque)
Un rayon laser-rappeur

| Scene | Duration | Panel | Duration |
|-------|----------|-------|----------|
| 128 | 04:10 | 3 | 00:10 |

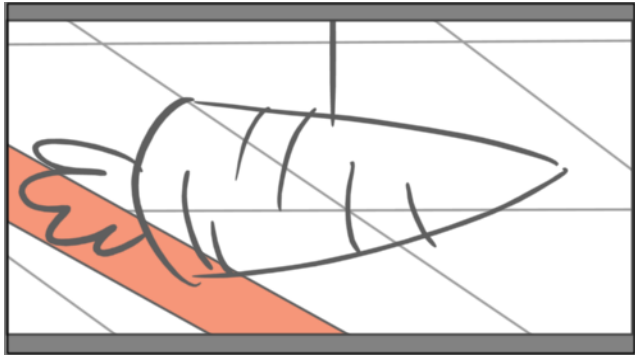

Dialogue

87. PIERROT (héroïque)
Un rayon laser-rappeur

| Scene | Duration | Panel | Duration |
|-------|----------|-------|----------|
| 128 | 04:10 | 4 | 01:00 |



| Scene | Duration | Panel | Duration |
|-------|----------|-------|----------|
| 128 | 04:10 | 5 | 01:00 |



Dialogue

SHBAM !

Action Notes

? PLAN MOULIN 5 (raccord avec le plan précédent en CUT)
?qui disparaît dans un nuage de fumée blanche (la farine) !

| Scene | Duration | Panel | Duration |
|-------|----------|-------|----------|
| 128 | 04:10 | 6 | 00:17 |

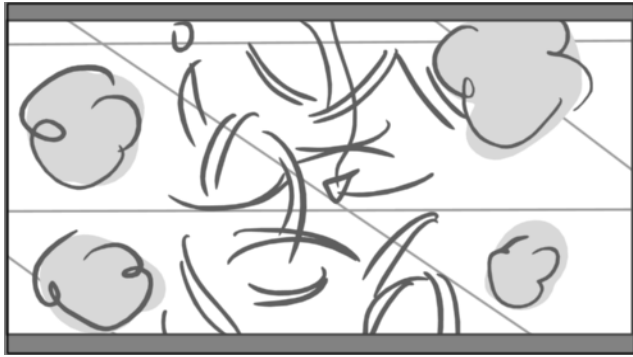

Action Notes

Carottes rapées IN OUT

| Scene | Duration | Panel | Duration |
|-------|----------|-------|----------|
| 128 | 04:10 | 7 | 00:15 |

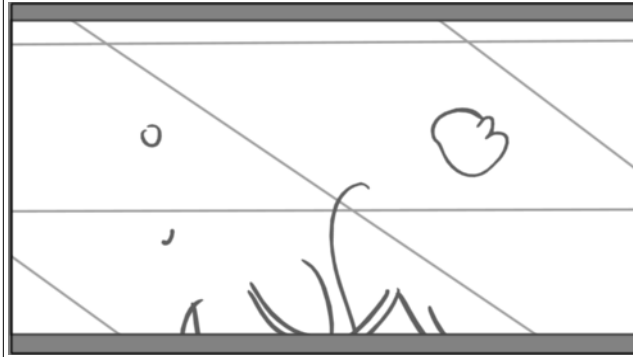

| Scene | Duration | Panel | Duration |
|-------|----------|-------|----------|
| 129 | 05:19 | 1 | 01:01 |



Dialogue

87. PIERROT (héroïque)
anti-carottes géantes !



| Scene | Duration | Panel | Duration |
|-------|----------|-------|----------|
| 129 | 05:19 | 2 | 01:01 |

| Scene | Duration | Panel | Duration |
|-------|----------|-------|----------|
| 129 | 05:19 | 3 | 01:01 |

NO PANEL

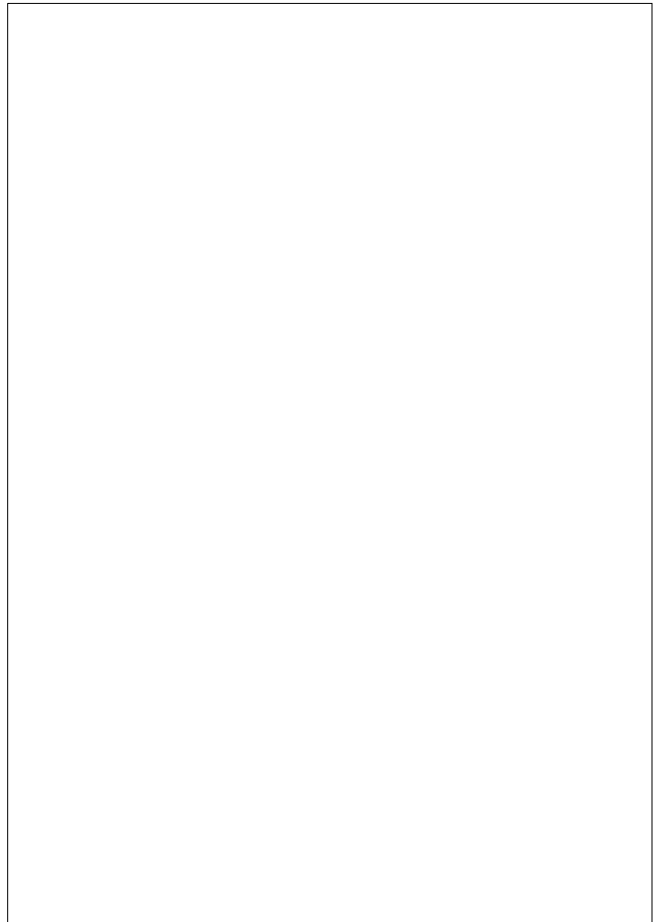
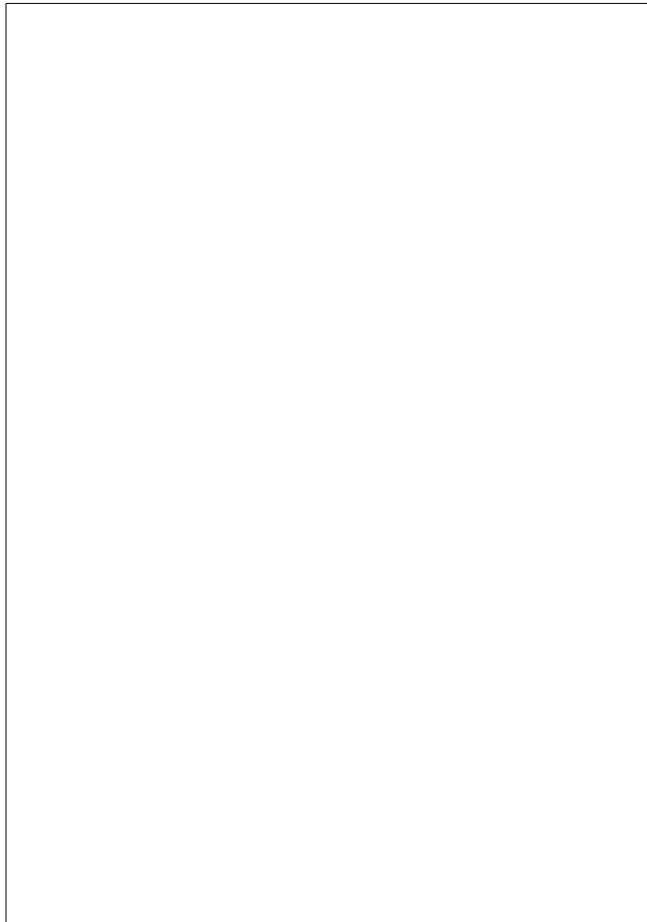
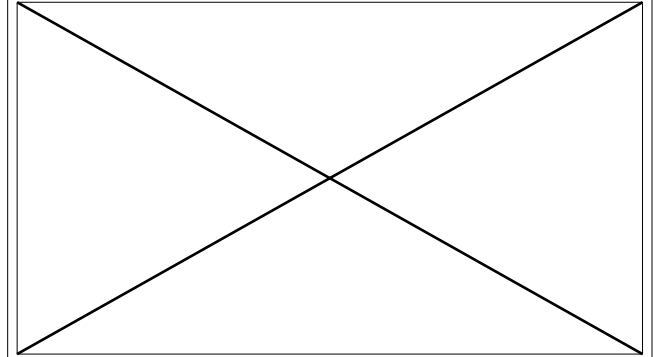
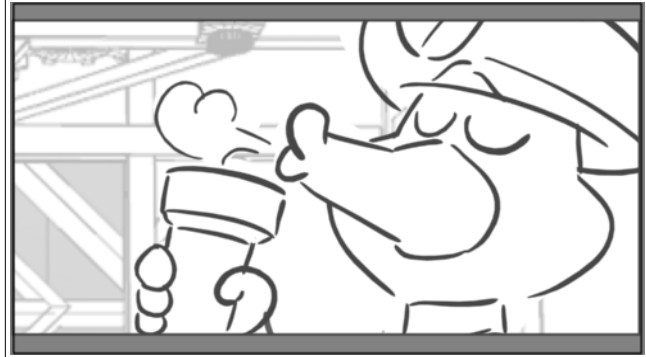

| Scene | Duration | Panel | Duration |
|-------|----------|-------|----------|
| 129 | 05:19 | 4 | 01:00 |

| Scene | Duration | Panel | Duration |
|-------|----------|-------|----------|
| 129 | 05:19 | 5 | 00:21 |

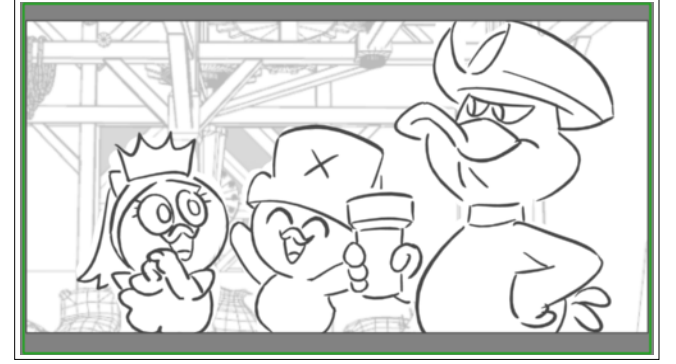
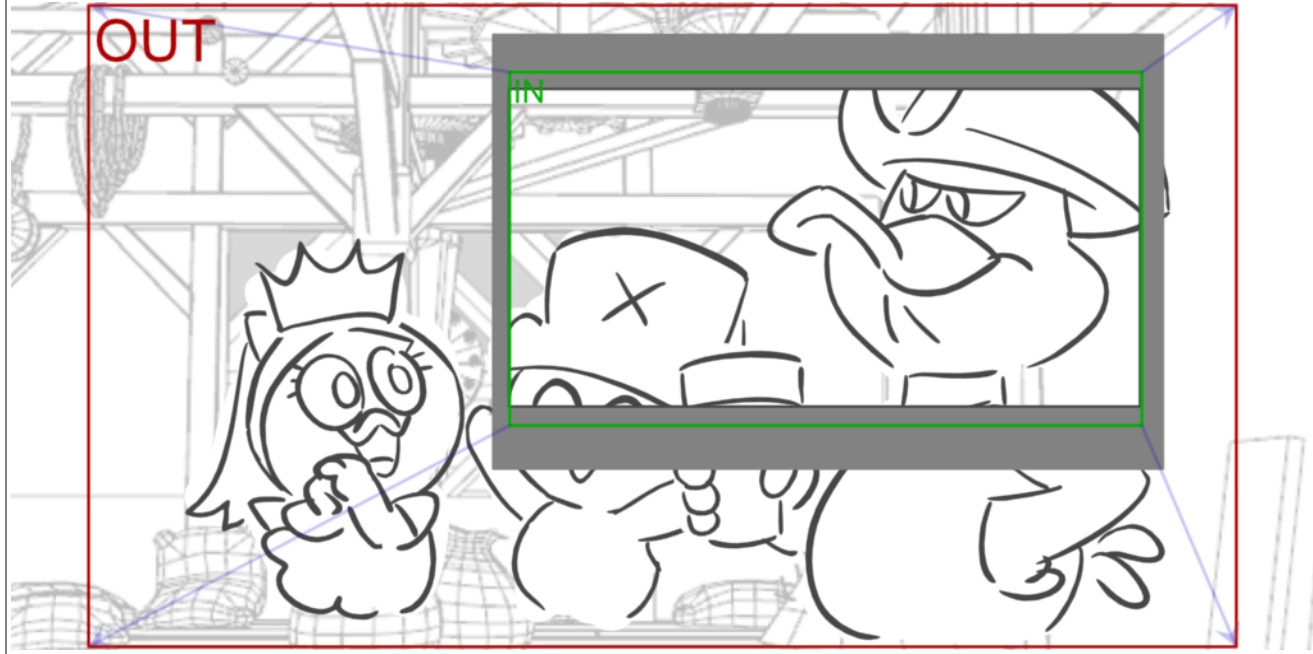

Dialogue

PICK UP PRISCILLA
bravo capitaine!

| Scene | Duration | Panel | Duration |
|-------|----------|-------|----------|
| 129 | 05:19 | 6 | 00:20 |

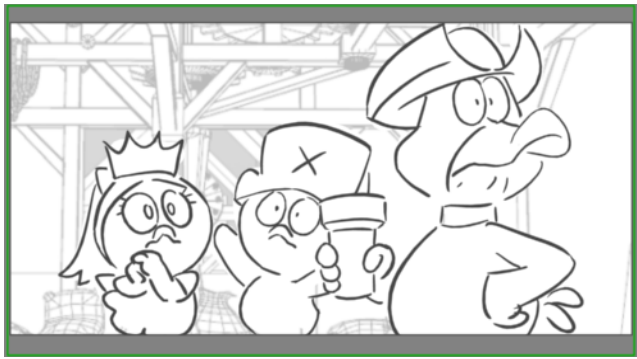

| Scene | Duration | Panel | Duration |
|-------|----------|-------|----------|
| 130 | 03:00 | 1 | 01:00 |

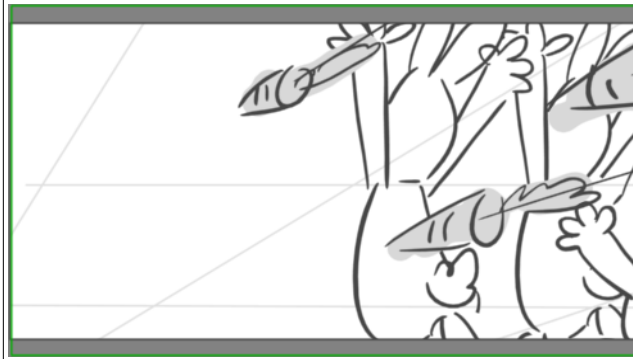

Dialogue

PICK UP LAPINET
Aaaahhh!

| Scene | Duration | Panel | Duration |
|-------|----------|-------|----------|
| 130 | 03:00 | 2 | 01:00 |

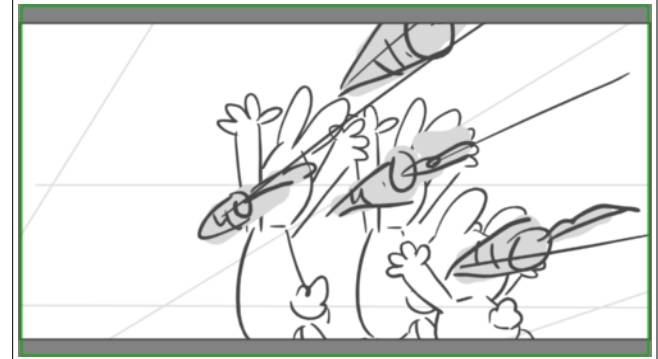

Dialogue

PICK UP LAPINET
Aaaahhh!

| Scene | Duration | Panel | Duration |
|-------|----------|-------|----------|
| 130 | 03:00 | 3 | 01:00 |

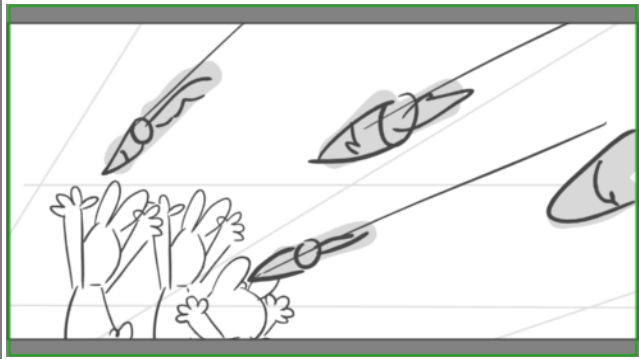

| Scene | Duration | Panel | Duration |
|-------|----------|-------|----------|
| 131 | 03:00 | 1 | 01:00 |

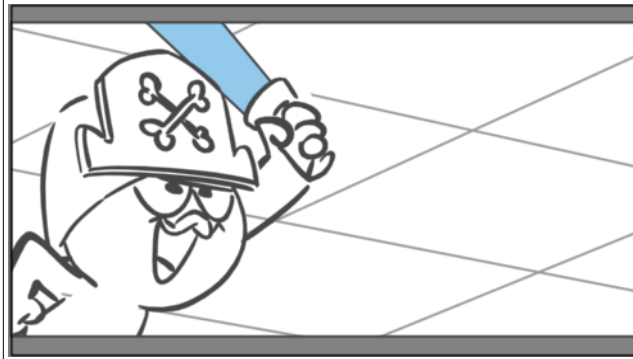

Dialogue
 89. PIERROT (héroïque)
 Allons sauver les Lapinet

| Scene | Duration | Panel | Duration |
|-------|----------|-------|----------|
| 131 | 03:00 | 2 | 01:00 |



Dialogue
 89. PIERROT (héroïque)
 Allons sauver les Lapinet

| Scene | Duration | Panel | Duration |
|-------|----------|-------|----------|
| 131 | 03:00 | 3 | 01:00 |



Dialogue
 89. PIERROT (héroïque)
 Allons sauver les Lapinet

| Scene | Duration | Panel | Duration |
|-------|----------|-------|----------|
| 132 | 03:09 | 1 | 00:17 |

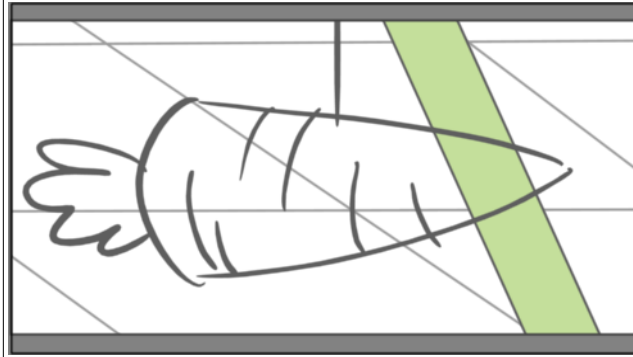

Dialogue
 92. CALIMERO (poussant un cri guerrier)
 Yarhaaa !

| Scene | Duration | Panel | Duration |
|-------|----------|-------|----------|
| 132 | 03:09 | 2 | 00:17 |

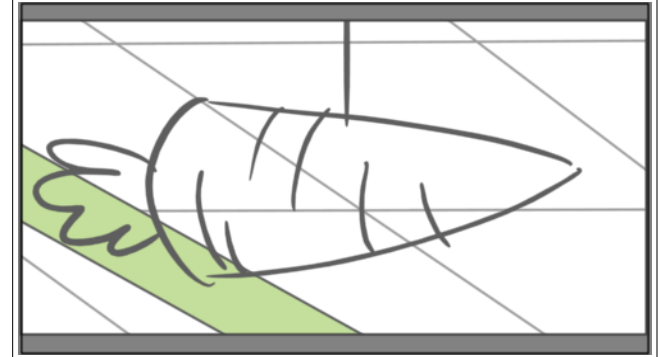

| Scene | Duration | Panel | Duration |
|-------|----------|-------|----------|
| 132 | 03:09 | 3 | 01:00 |



| Scene | Duration | Panel | Duration |
|-------|----------|-------|----------|
| 132 | 03:09 | 4 | 01:00 |



Dialogue
SHBAM !

| Scene | Duration | Panel | Duration |
|-------|----------|-------|----------|
| 133 | 03:08 | 1 | 00:15 |

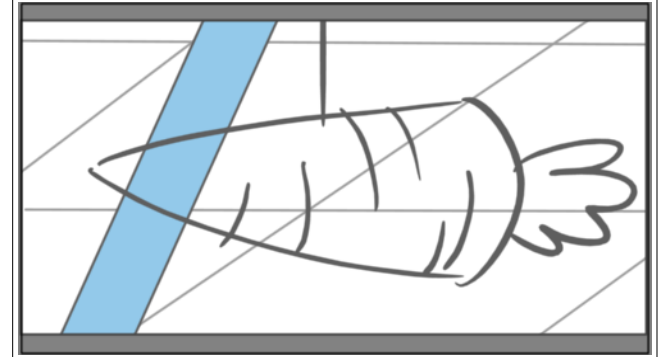

Dialogue
93. PIERROT
Sus aux carooottes !



| Scene | Duration | Panel | Duration |
|-------|----------|-------|----------|
| 133 | 03:08 | 2 | 00:18 |

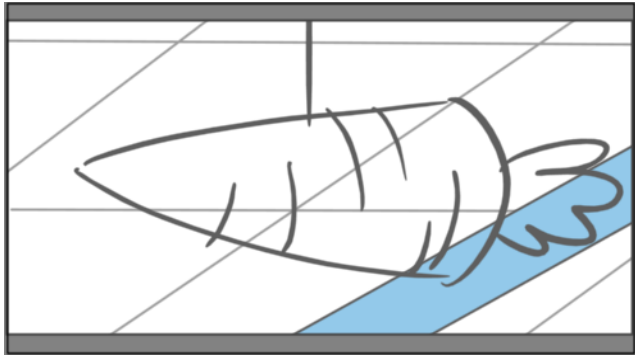

| Scene | Duration | Panel | Duration |
|-------|----------|-------|----------|
| 133 | 03:08 | 3 | 01:00 |



| Scene | Duration | Panel | Duration |
|-------|----------|-------|----------|
| 133 | 03:08 | 4 | 01:00 |



Dialogue

SHBAM !

| Scene | Duration | Panel | Duration |
|-------|----------|-------|----------|
| 134 | 06:06 | 1 | 01:10 |

| Scene | Duration | Panel | Duration |
|-------|----------|-------|----------|
| 134 | 06:06 | 2 | 00:18 |

| Scene | Duration | Panel | Duration |
|-------|----------|-------|----------|
| 134 | 06:06 | 3 | 00:16 |

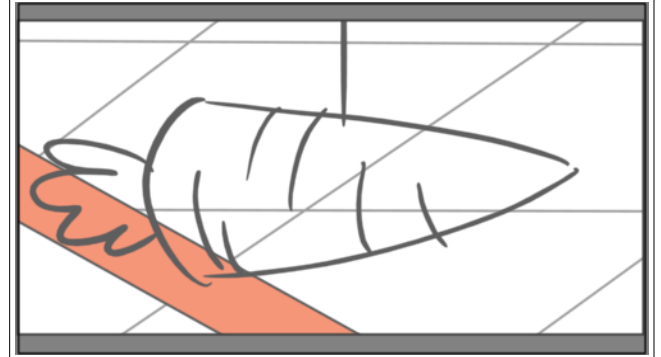
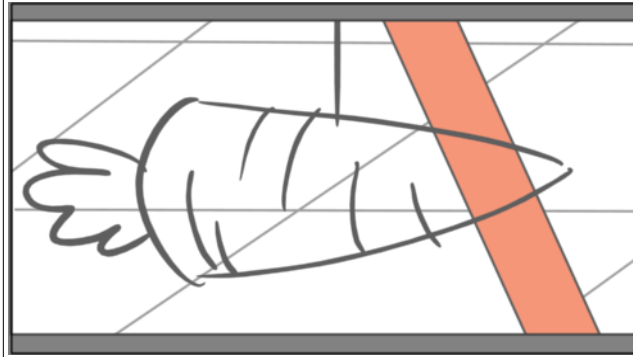
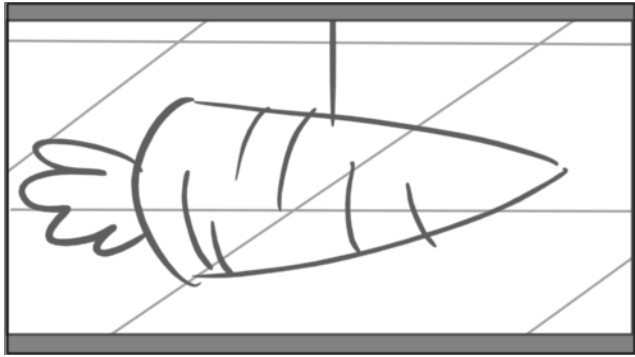

Dialogue

94. PRISCILLA

Les carottes sont cuuuuities !



| Scene | Duration | Panel | Duration |
|-------|----------|-------|----------|
| 134 | 06:06 | 4 | 01:00 |



| Scene | Duration | Panel | Duration |
|-------|----------|-------|----------|
| 134 | 06:06 | 5 | 01:00 |



Dialogue
SHBAM !

| Scene | Duration | Panel | Duration |
|-------|----------|-------|----------|
| 134 | 06:06 | 6 | 00:18 |

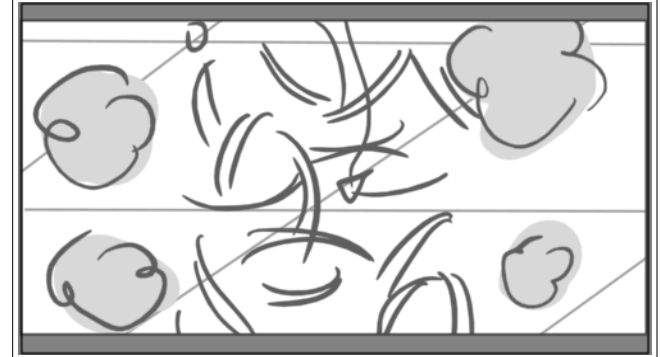

Action Notes
Carottes rapées IN OUT

| Scene | Duration | Panel | Duration |
|-------|----------|-------|----------|
| 134 | 06:06 | 7 | 00:19 |

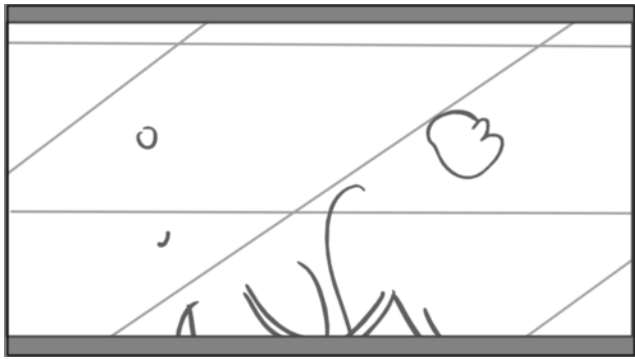

| Scene | Duration | Panel | Duration |
|-------|----------|-------|----------|
| 135 | 03:00 | 1 | 00:08 |

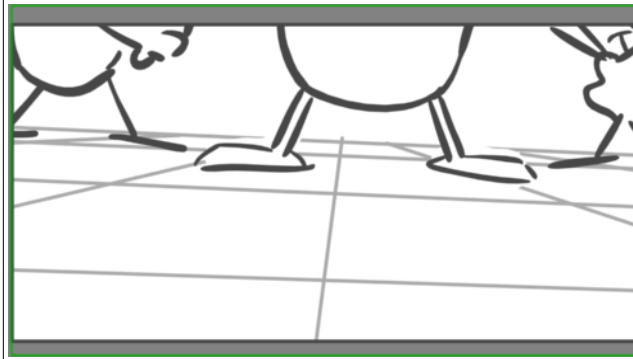

| Scene | Duration | Panel | Duration |
|-------|----------|-------|----------|
| 135 | 03:00 | 2 | 00:17 |

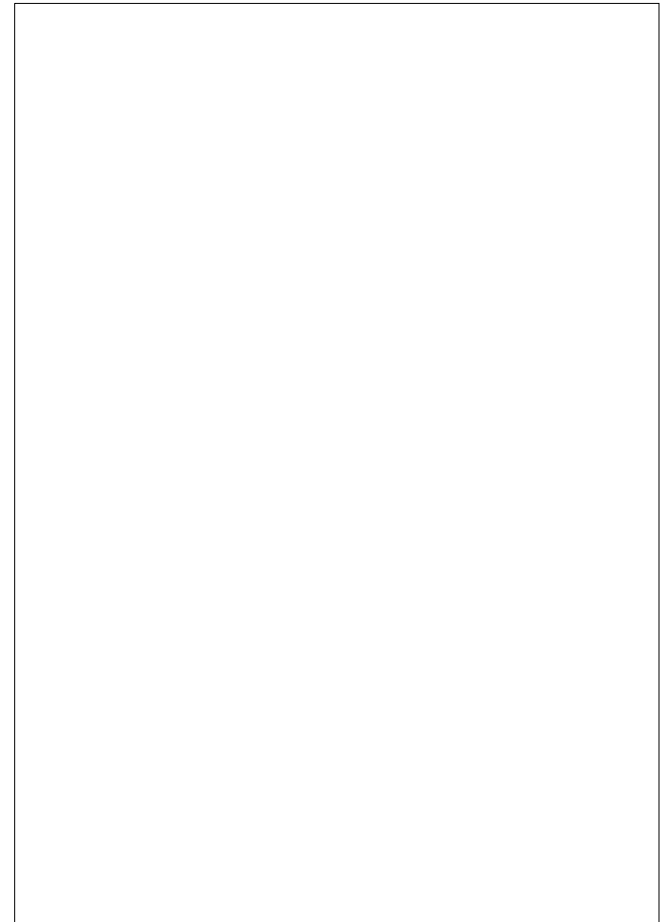
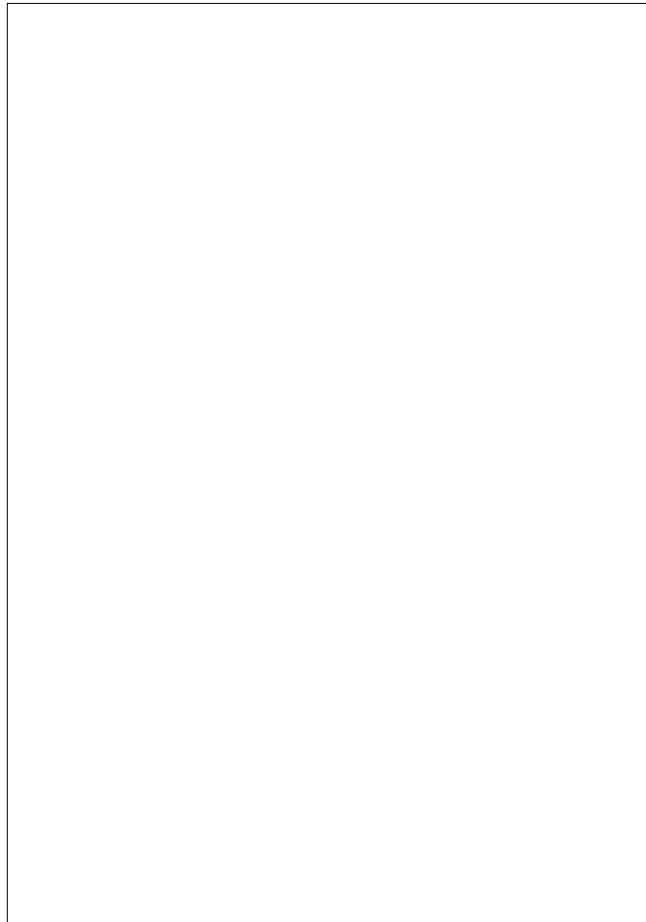
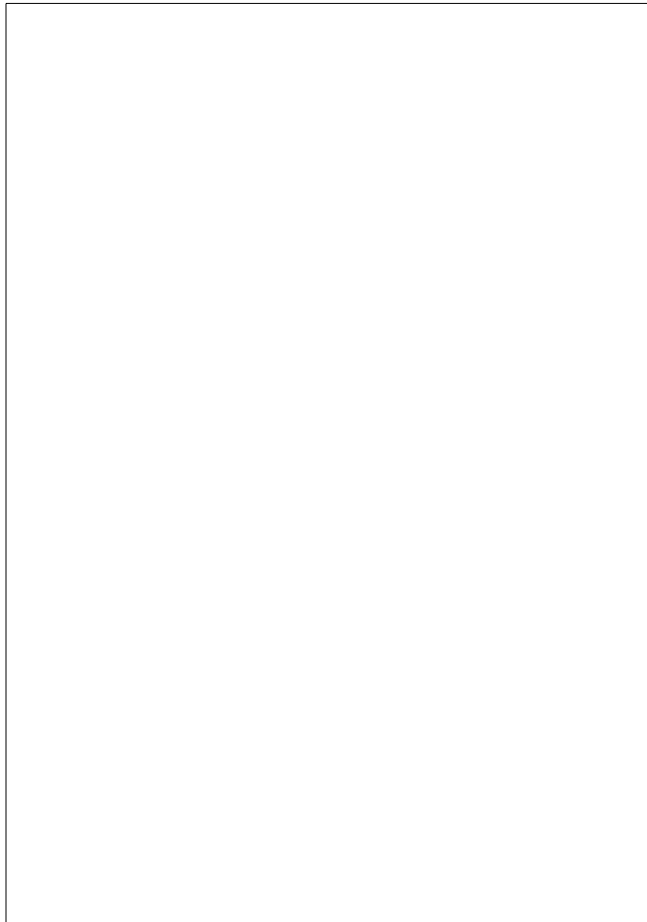
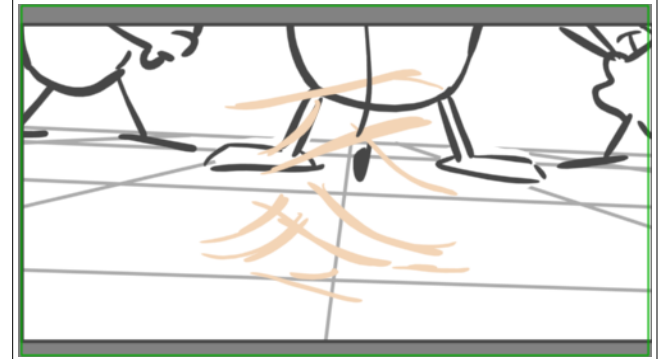

| | | | |
|-------|----------|-------|----------|
| Scene | Duration | Panel | Duration |
| 135 | 03:00 | 3 | 01:00 |

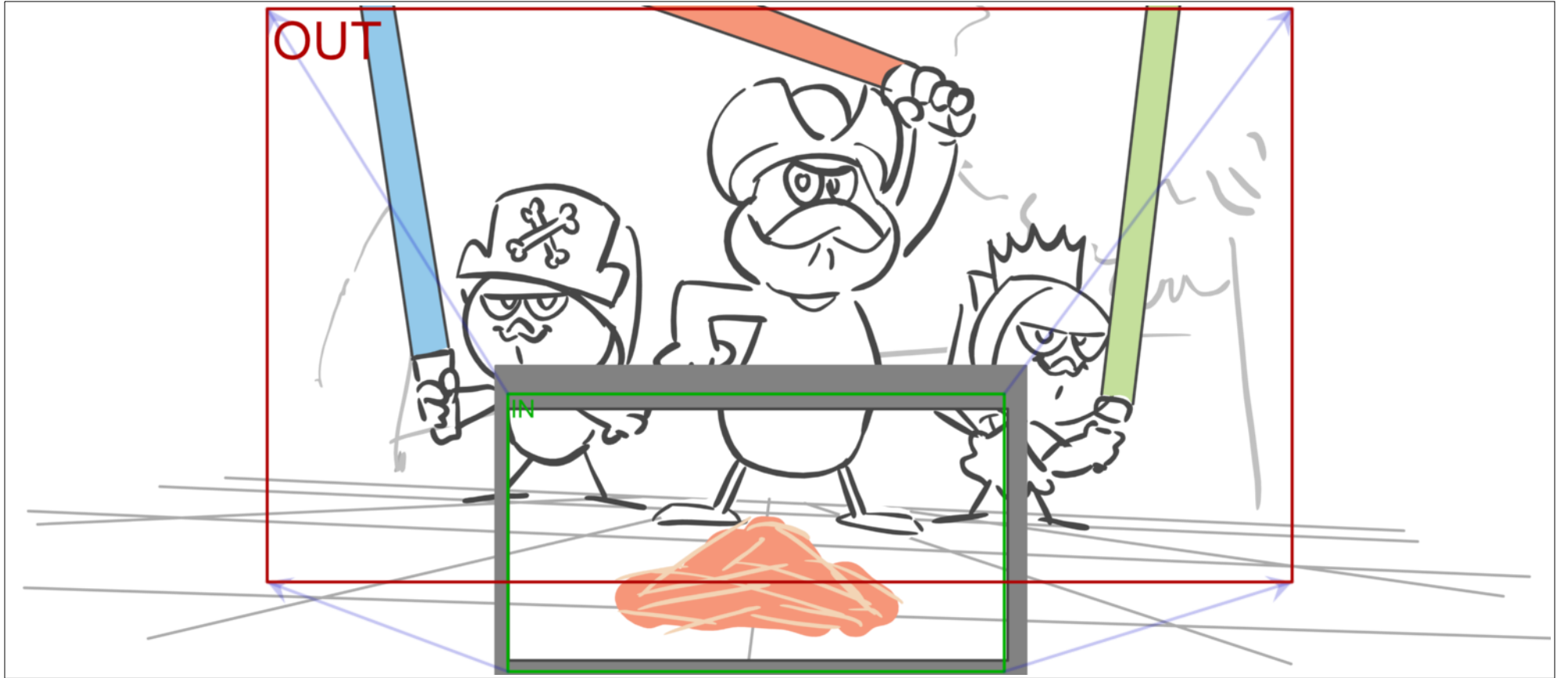

| Scene | Duration | Panel | Duration |
|-------|----------|-------|----------|
| 135 | 03:00 | 4 | 01:00 |



Dialogue

89. PIERROT (héroïque)
Allons sauver les Lapinet

| Scene | Duration | Panel | Duration |
|-------|----------|-------|----------|
| 136 | 03:13 | 1 | 01:00 |

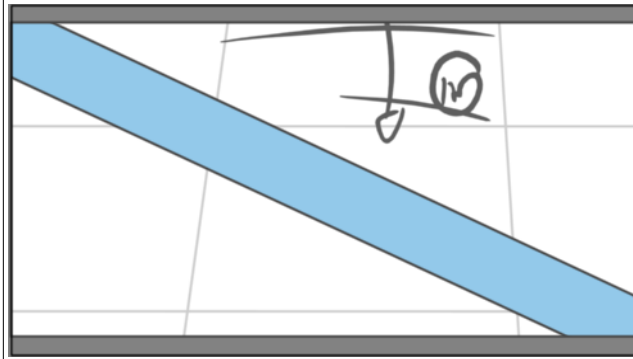

Dialogue

95.
CALIMERO/PRISCILLA/VALERIANO/PIERROTS
(en chœur)
Parole de poussins et foi de canard,

| Scene | Duration | Panel | Duration |
|-------|----------|-------|----------|
| 136 | 03:13 | 2 | 01:00 |

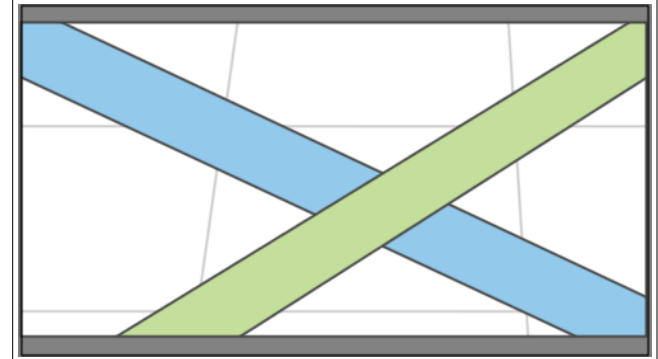

Dialogue

95.
CALIMERO/PRISCILLA/VALERIANO/PIERROTS
(en chœur)
Parole de poussins et foi de canard,

| Scene | Duration | Panel | Duration |
|-------|----------|-------|----------|
| 136 | 03:13 | 3 | 01:13 |

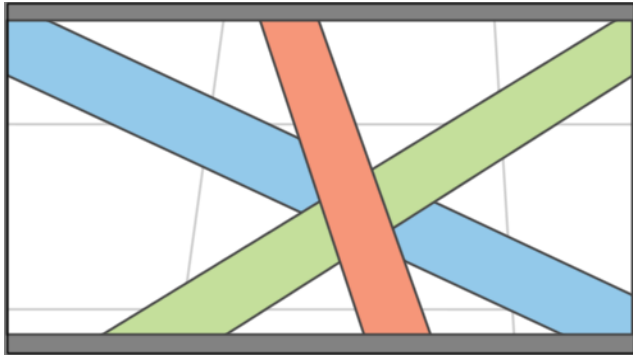

Dialogue

95.
 CALIMERO/PRISCILLA/VALERIANO/PIERROTS
 (en chœur)
 Parole de poussins et foi de canard,

| Scene | Duration | Panel | Duration |
|-------|----------|-------|----------|
| 137 | 06:16 | 1 | 02:21 |

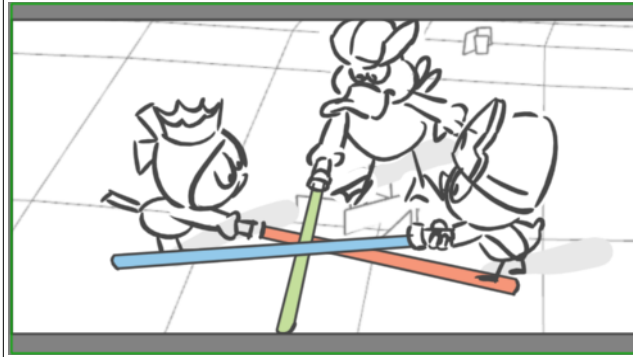

Dialogue

95.
 CALIMERO/PRISCILLA/VALERIANO/PIERROTS
 (en chœur)
 nous défendrons toujours les lapins
 face aux vilaines carottes
 extra-terrestres !

NO PANEL

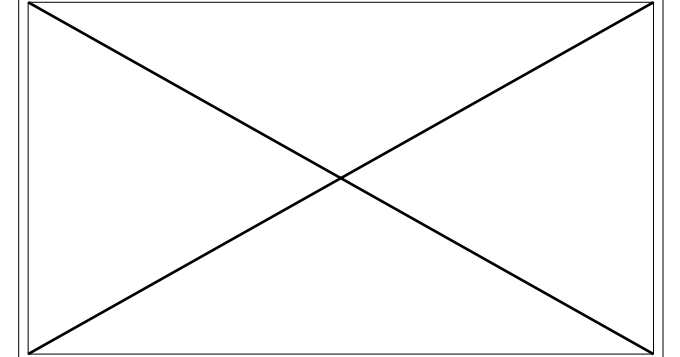

(This area is empty, representing the missing dialogue for the 'NO PANEL' section.)

| Scene | Duration | Panel | Duration |
|-------|----------|-------|----------|
| 137 | 06:16 | 2 | 01:10 |

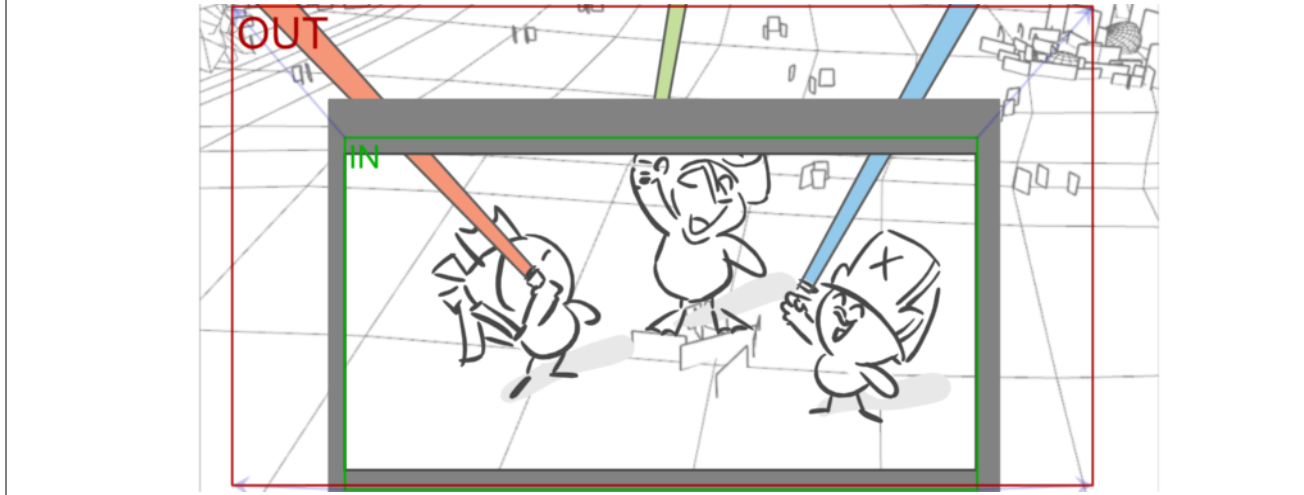
**Dialogue**

95. CALIMERO/PRISCILLA/VALERIANO/PIERROTS (en chœur)
 nous défendrons toujours les lapins face aux vilaines carottes extra-terrestres !

| Scene | Duration | Panel | Duration |
|-------|----------|-------|----------|
| 137 | 06:16 | 3 | 02:10 |

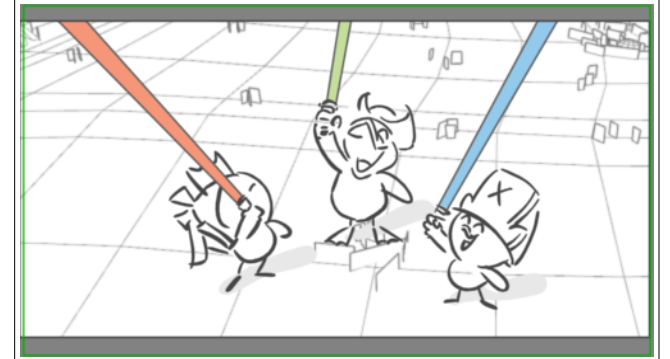
**Dialogue**

95.
 CALIMERO/PRISCILLA/VALERIANO/PIERROTS
 (en chœur)
 nous défendrons toujours les lapins
 face aux vilaines carottes
 extra-terrestres !

| Scene | Duration | Panel | Duration |
|-------|----------|-------|----------|
| 138 | 03:01 | 1 | 00:11 |



Dialogue
SFX LAPINET
Aie aie ouille!!!

| Scene | Duration | Panel | Duration |
|-------|----------|-------|----------|
| 138 | 03:01 | 2 | 02:15 |



Dialogue
96. PUBLIC (hilare)
Bravo ! Bravo !

| Scene | Duration | Panel | Duration |
|-------|----------|-------|----------|
| 139 | 04:14 | 1 | 01:00 |



Dialogue
96. MOT
Bravo ! Bravo !

| | | | |
|-------|----------|-------|----------|
| Scene | Duration | Panel | Duration |
| 139 | 04:14 | 2 | 01:00 |

NO PANEL

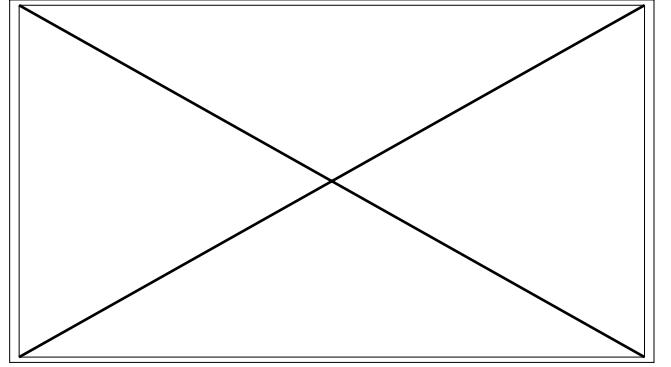
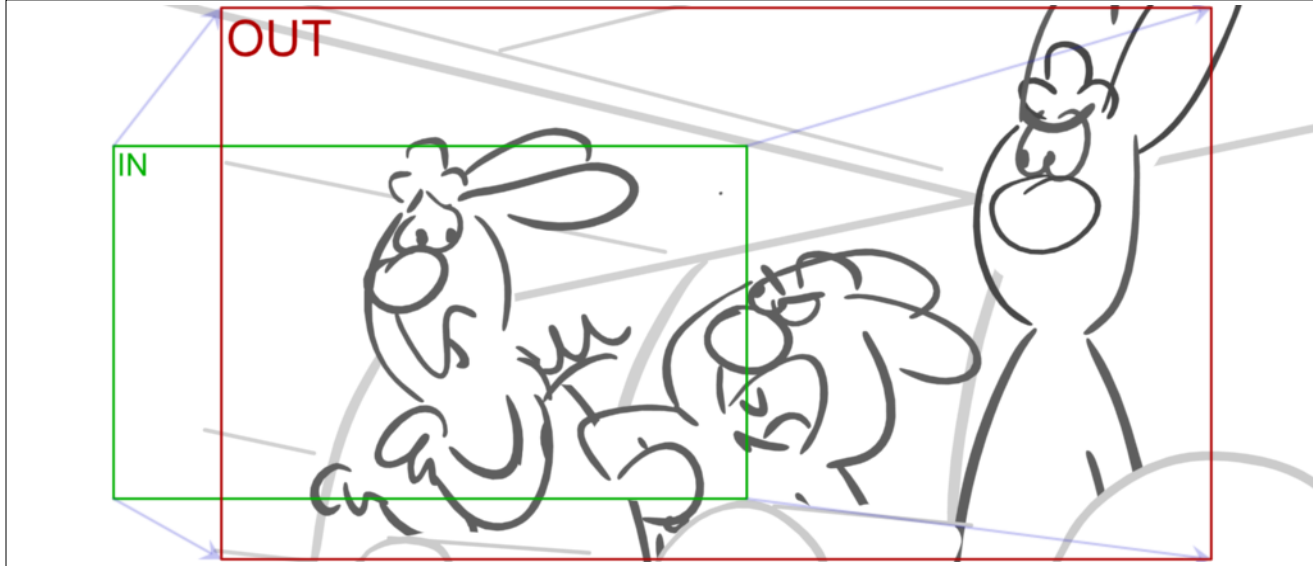

Dialogue
PICK UP POT
Arrête d'applaudir imbécile!

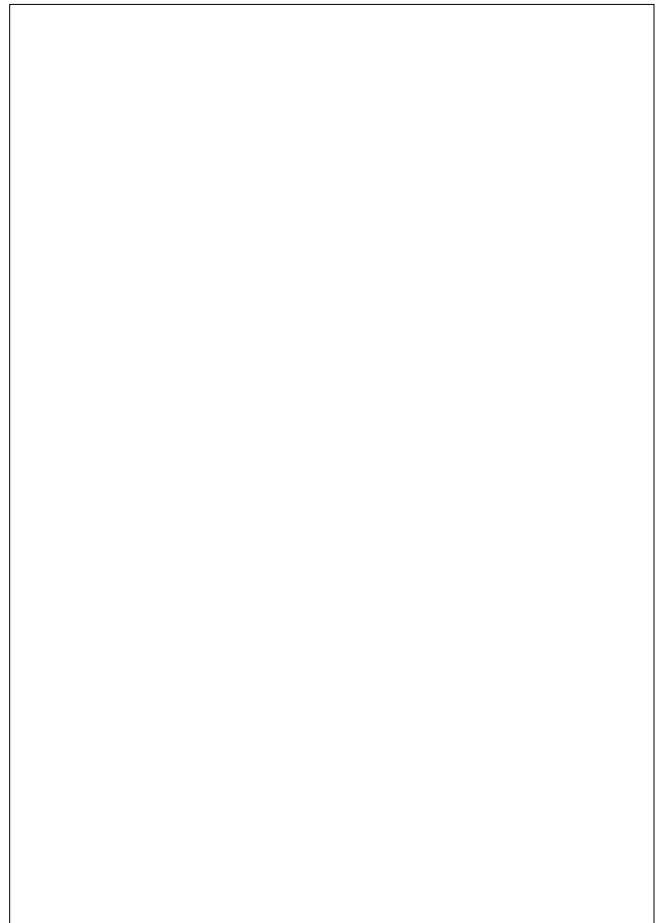



| Scene | Duration | Panel | Duration |
|-------|----------|-------|----------|
| 139 | 04:14 | 3 | 00:07 |

| Scene | Duration | Panel | Duration |
|-------|----------|-------|----------|
| 139 | 04:14 | 4 | 00:05 |



Dialogue

97. POT
Grrr !

Dialogue

97. POT
Grrr !

| Scene | Duration | Panel | Duration |
|-------|----------|-------|----------|
| 139 | 04:14 | 5 | 00:07 |

| Scene | Duration | Panel | Duration |
|-------|----------|-------|----------|
| 139 | 04:14 | 6 | 00:05 |

| Scene | Duration | Panel | Duration |
|-------|----------|-------|----------|
| 139 | 04:14 | 7 | 00:07 |



Dialogue

97. POT
Grrr !

Dialogue

97. POT
Grrr !

Dialogue

97. POT
Grrr !

| Scene | Duration | Panel | Duration |
|-------|----------|-------|----------|
| 139 | 04:14 | 8 | 00:05 |

| Scene | Duration | Panel | Duration |
|-------|----------|-------|----------|
| 139 | 04:14 | 9 | 00:06 |

| Scene | Duration | Panel | Duration |
|-------|----------|-------|----------|
| 139 | 04:14 | 10 | 00:22 |



Dialogue

97. POT
Grrr !

Dialogue

97. POT
Grrr !

Dialogue

97. POT
Grrr !

| | |
|----------|-------------------|
| Dissolve | Duration 00:21 |
|----------|-------------------|

| | | | |
|--------------|-------------------|------------|-------------------|
| Scene 140 | Duration 07:07 | Panel 1 | Duration 07:07 |
|--------------|-------------------|------------|-------------------|

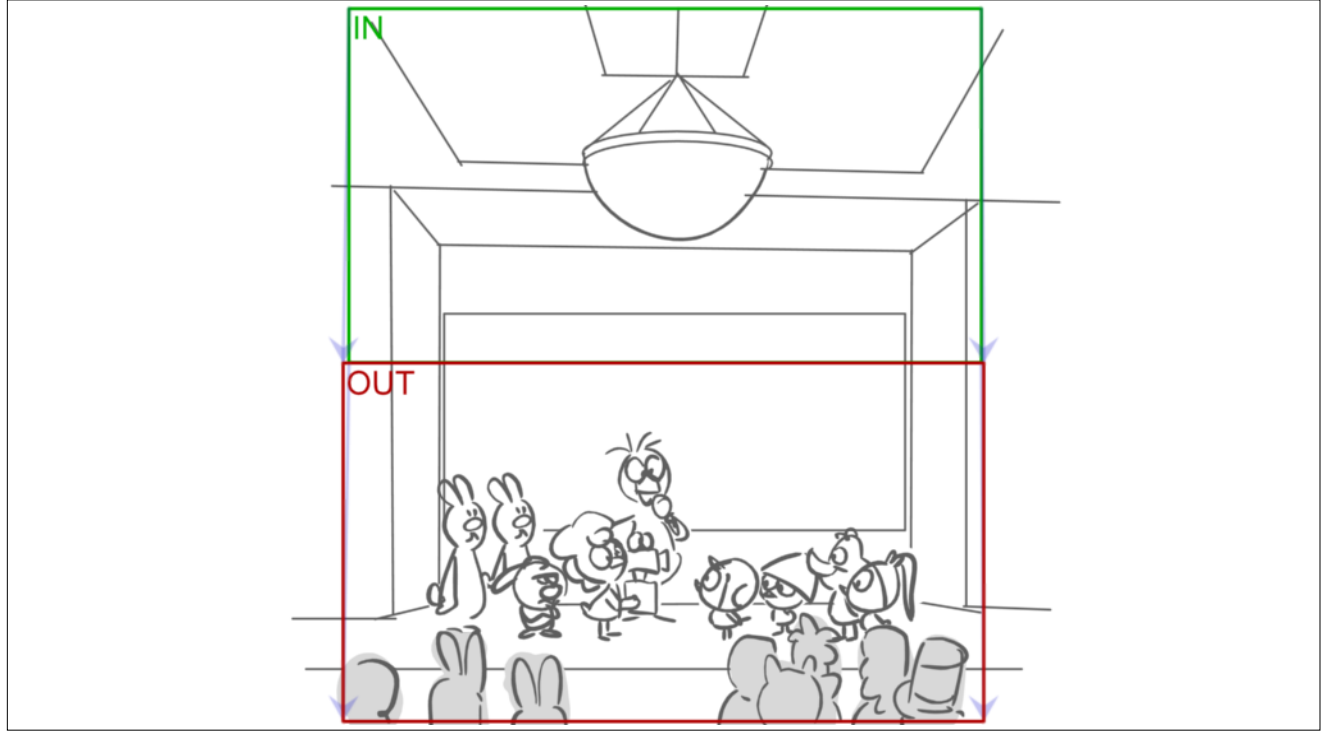

Dialogue
 98. M. KINOS (au micro)
 Le jury est unanime, le prix du « Meilleur petit cinéaste » est attribué à Valériano !

Action Notes
 INT salle de cine/soir/plus tard

| Scene | Duration | Panel | Duration |
|-------|----------|-------|----------|
| 141 | 02:24 | 1 | 00:09 |



Dialogue
 99. VALERIANO (au micro de M. Kinos)
 Wouaaa

| Scene | Duration | Panel | Duration |
|-------|----------|-------|----------|
| 141 | 02:24 | 2 | 00:17 |



Dialogue
 99. VALERIANO (au micro de M. Kinos)
 Wouaaa

| Scene | Duration | Panel | Duration |
|-------|----------|-------|----------|
| 141 | 02:24 | 3 | 01:00 |



Dialogue
 99. VALERIANO (au micro de M. Kinos)
 trop méga !

| Scene | Duration | Panel | Duration |
|-------|----------|-------|----------|
| 141 | 02:24 | 4 | 00:23 |



| Scene | Duration | Panel | Duration |
|-------|----------|-------|----------|
| 142 | 01:13 | 1 | 01:13 |

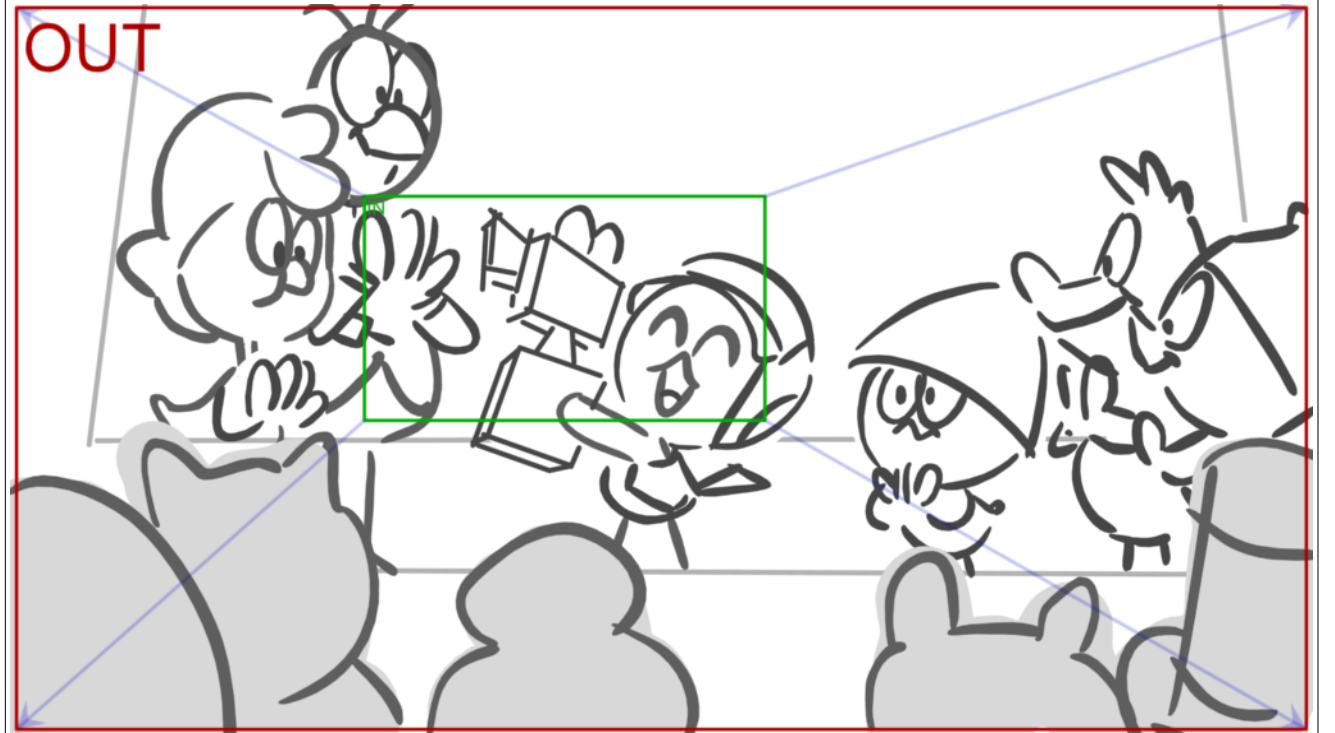

Dialogue

99. VALERIANO (au micro de M. Kinos)
 Merci à tous !

| Scene | Duration | Panel | Duration |
|-------|----------|-------|----------|
| 143 | 02:02 | 1 | 02:02 |



Dialogue

96. PUBLIC (hilare)
Bravo ! Bravo !

| Scene | Duration | Panel | Duration |
|-------|----------|-------|----------|
| 144 | 05:16 | 1 | 03:16 |

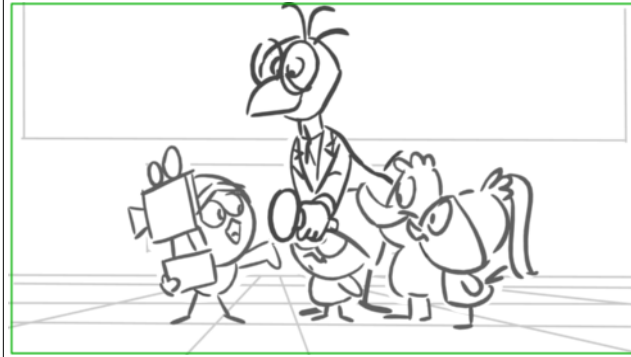

Dialogue

99. VALERIANO (au micro de M. Kinos)
Merci à mes amis qui ont été de
méga-acteurs!

| Scene | Duration | Panel | Duration |
|-------|----------|-------|----------|
| 144 | 05:16 | 2 | 00:10 |

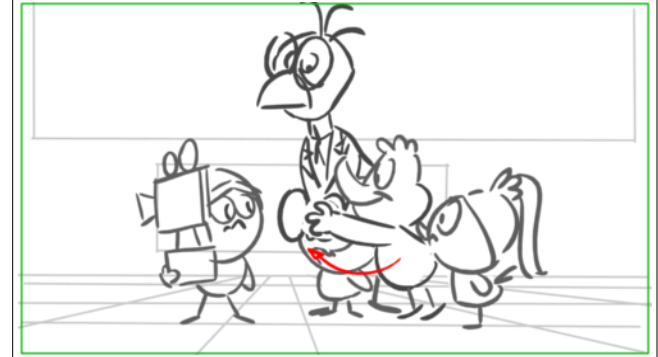

Dialogue

96. PUBLIC (hilare)
Bravo ! Bravo !

Action Notes

pierrot arrache le micro des mains de
M.Kinos

| Scene | Duration | Panel | Duration |
|-------|----------|-------|----------|
| 144 | 05:16 | 3 | 00:15 |

| Scene | Duration | Panel | Duration |
|-------|----------|-------|----------|
| 144 | 05:16 | 4 | 01:00 |

| Scene | Duration | Panel | Duration |
|-------|----------|-------|----------|
| 145 | 07:03 | 1 | 01:12 |

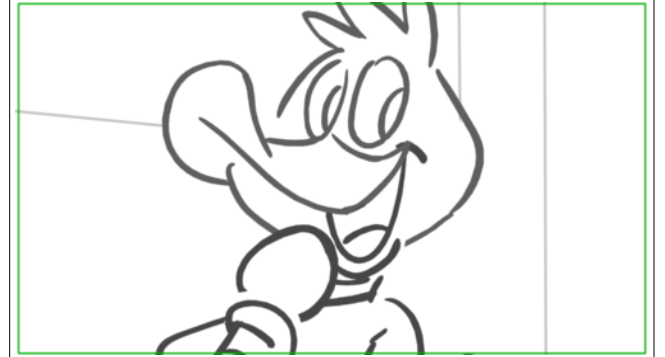
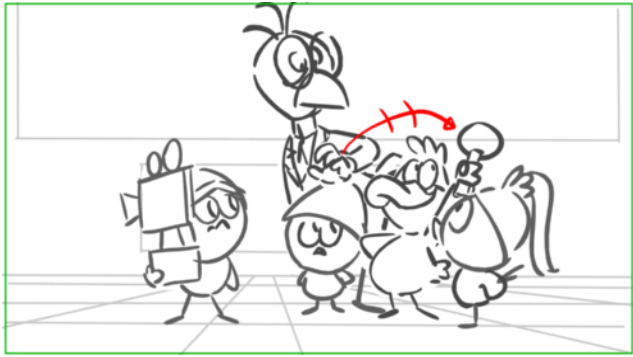

Dialogue
 96. PUBLIC (hilare)
 Bravo ! Bravo !

| Scene | Duration | Panel | Duration |
|-------|----------|-------|----------|
| 145 | 07:03 | 2 | 02:03 |

| Scene | Duration | Panel | Duration |
|-------|----------|-------|----------|
| 145 | 07:03 | 3 | 00:13 |

| Scene | Duration | Panel | Duration |
|-------|----------|-------|----------|
| 145 | 07:03 | 4 | 00:13 |

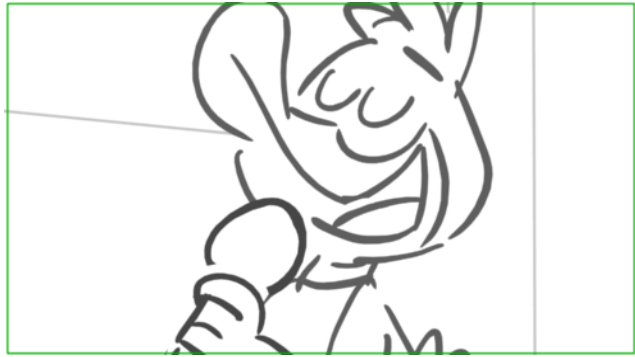

Dialogue

100. PIERROT
 et surtout le réalisateur de m?avoir
 laissé ma chance !

| Scene | Duration | Panel | Duration |
|-------|----------|-------|----------|
| 145 | 07:03 | 5 | 02:12 |



Dialogue

100. PIERROT
J'ai hâte de tourner la suite !

| Scene | Duration | Panel | Duration |
|-------|----------|-------|----------|
| 146 | 08:01 | 1 | 00:12 |

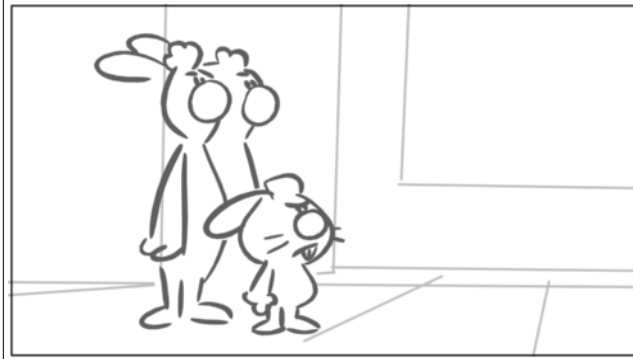

Dialogue

99. VALERIANO (au micro de M. Kinos)
Et merci aussi aux Lapinet !

| Scene | Duration | Panel | Duration |
|-------|----------|-------|----------|
| 146 | 08:01 | 2 | 01:24 |

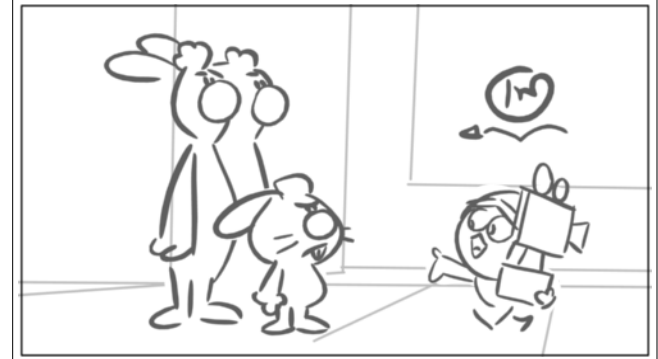

Dialogue

99. VALERIANO (au micro de M. Kinos)
Et merci aussi aux Lapinet !

| Scene | Duration | Panel | Duration |
|-------|----------|-------|----------|
| 146 | 08:01 | 3 | 01:00 |

| Scene | Duration | Panel | Duration |
|-------|----------|-------|----------|
| 146 | 08:01 | 4 | 01:00 |

| Scene | Duration | Panel | Duration |
|-------|----------|-------|----------|
| 146 | 08:01 | 5 | 01:24 |

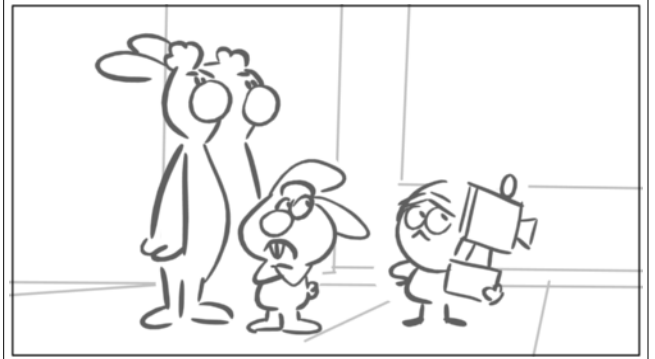
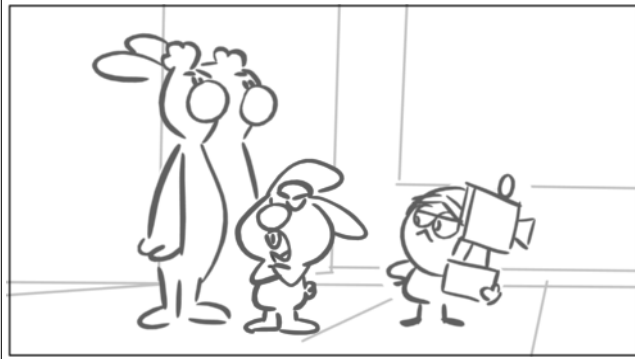
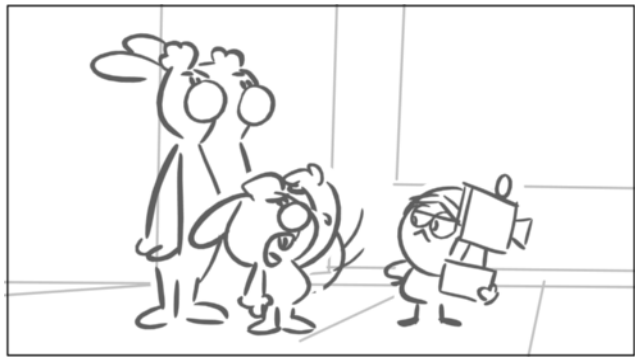

Dialogue
 PICK UP POT
 Peuh!

Dialogue
 101. MME GIGI
 Quand à vous, Pot, Cot et Mot,

| Scene | Duration | Panel | Duration |
|-------|----------|-------|----------|
| 146 | 08:01 | 6 | 01:16 |

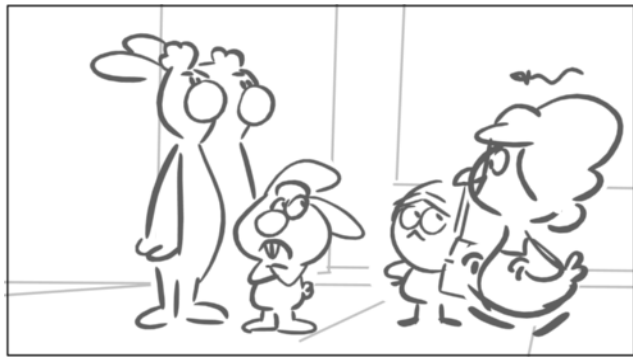

Dialogue
 101. MME GIGI
 Quand à vous, Pot, Cot et Mot,

| Scene | Duration | Panel | Duration |
|-------|----------|-------|----------|
| 147 | 06:02 | 1 | 00:16 |



Dialogue
 101. MME GIGI
 le jury a décidé de vous offrir

| Scene | Duration | Panel | Duration |
|-------|----------|-------|----------|
| 147 | 06:02 | 2 | 02:23 |

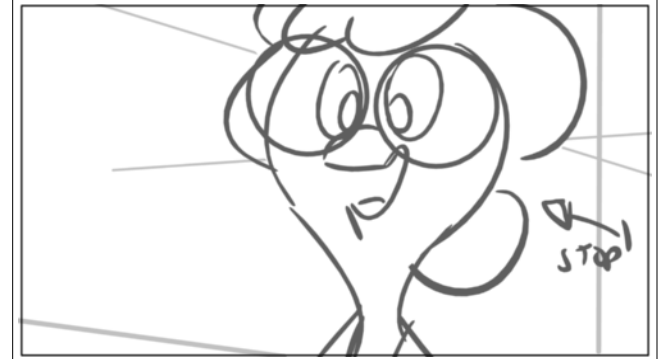

Dialogue
 101. MME GIGI
 le jury a décidé de vous offrir

| Scene | Duration | Panel | Duration |
|-------|----------|-------|----------|
| 147 | 06:02 | 3 | 02:13 |



Dialogue

101. MME GIGI
le prix spécial du scénario le plus
banal !

| Scene | Duration | Panel | Duration |
|-------|----------|-------|----------|
| 148 | 02:00 | 1 | 01:00 |

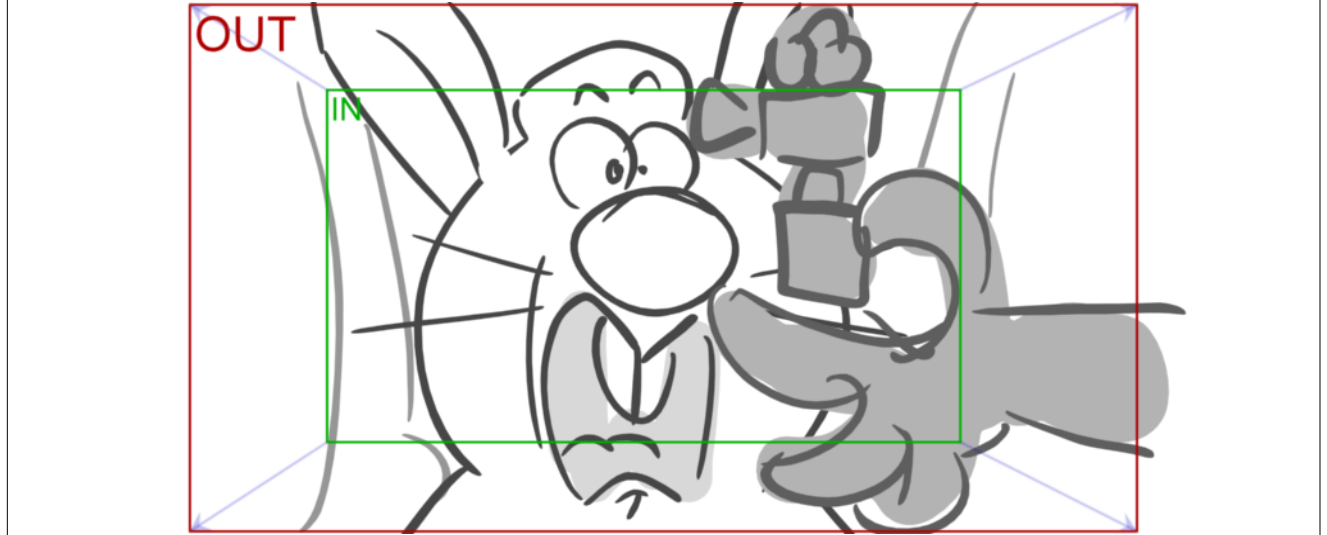

Dialogue

78. POT
HEIIINN ?!!

| Scene | Duration | Panel | Duration |
|-------|----------|-------|----------|
| 148 | 02:00 | 2 | 01:00 |

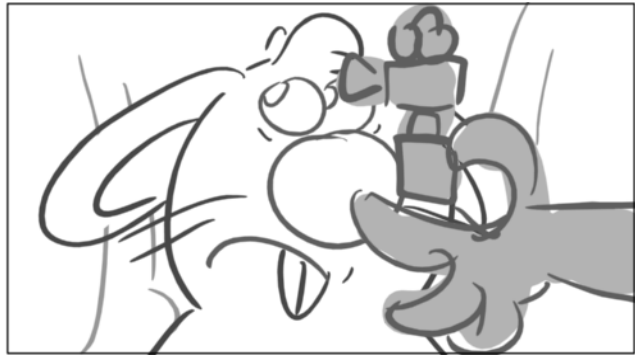

Dialogue

103. MOT (ému, caméra argentée en main)
Ohhh, merciiii ! merciiii !

| Scene | Duration | Panel | Duration |
|-------|----------|-------|----------|
| 149 | 08:04 | 1 | 01:00 |

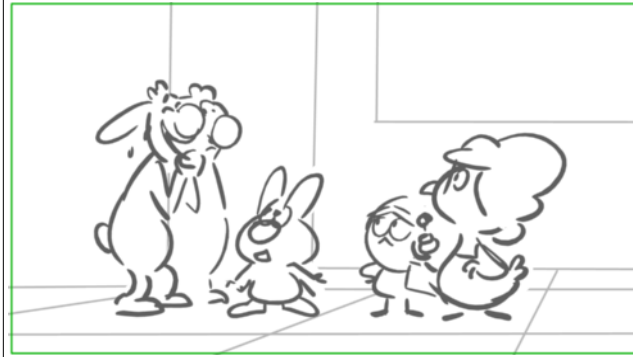

Dialogue

103. MOT (ému, caméra argentée en main)
C'est le plus beau jour de ma vie !...

| Scene | Duration | Panel | Duration |
|-------|----------|-------|----------|
| 149 | 08:04 | 2 | 01:15 |



Dialogue

103. MOT (ému, caméra argentée en main)
C'est le plus beau jour de ma vie !...

| Scene | Duration | Panel | Duration |
|-------|----------|-------|----------|
| 149 | 08:04 | 3 | 01:00 |



Dialogue
 102. POT (grognent, sourires crispés)
 Grrr?

| Scene | Duration | Panel | Duration |
|-------|----------|-------|----------|
| 149 | 08:04 | 4 | 00:16 |



Dialogue
 PICK UP POT
 Idiot!

| Scene | Duration | Panel | Duration |
|-------|----------|-------|----------|
| 149 | 08:04 | 5 | 00:18 |

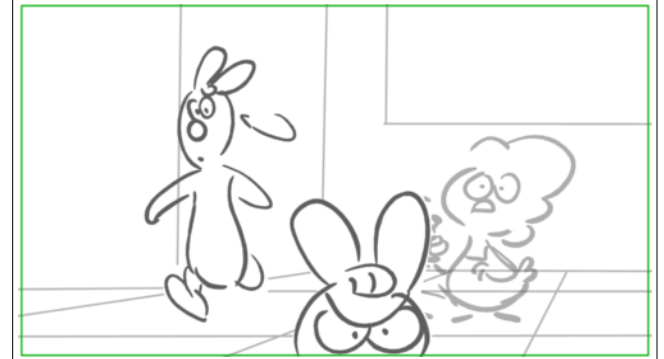

Dialogue
 PICK UP POT
 Reviens ici!

| Scene | Duration | Panel | Duration |
|-------|----------|-------|----------|
| 149 | 08:04 | 6 | 00:19 |

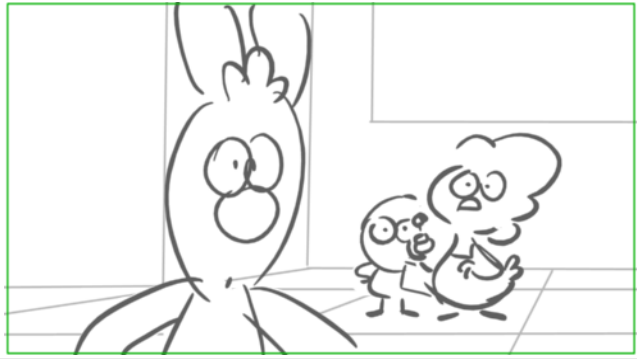

| Scene | Duration | Panel | Duration |
|-------|----------|-------|----------|
| 149 | 08:04 | 7 | 00:19 |

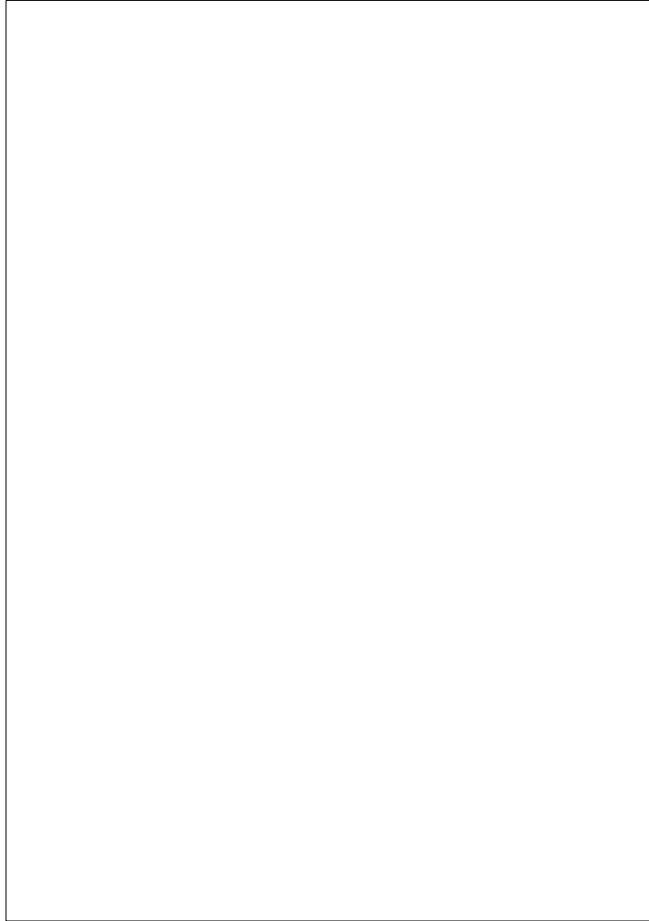
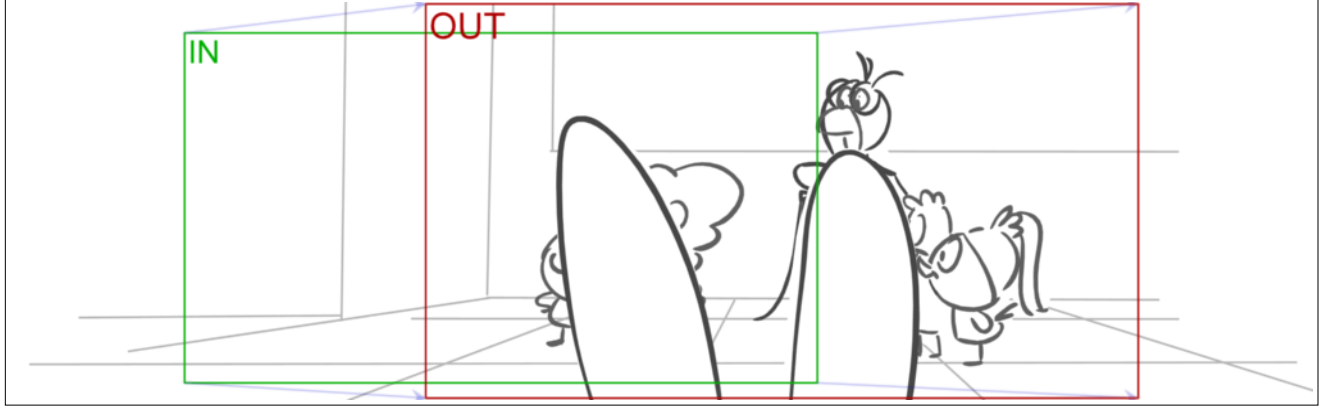

| Scene | Duration | Panel | Duration |
|-------|----------|-------|----------|
| 149 | 08:04 | 8 | 00:15 |

| Scene | Duration | Panel | Duration |
|-------|----------|-------|----------|
| 149 | 08:04 | 9 | 01:02 |

NO PANEL

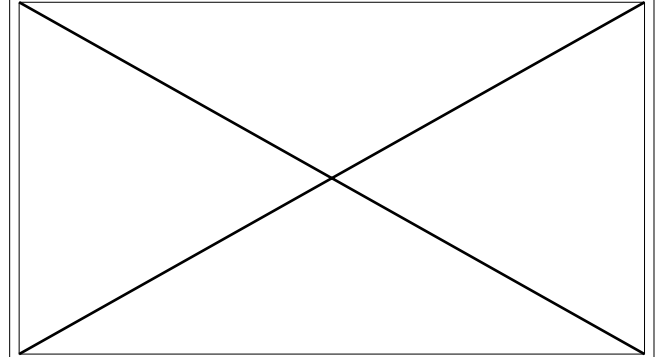
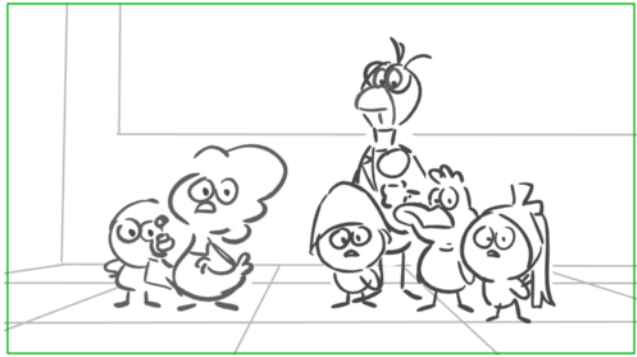

Dialogue
RIRES