



# #CZ

## EPISODE : BEST XMAS EVER



	PAGE
	1

scène	Cam . reu	Time

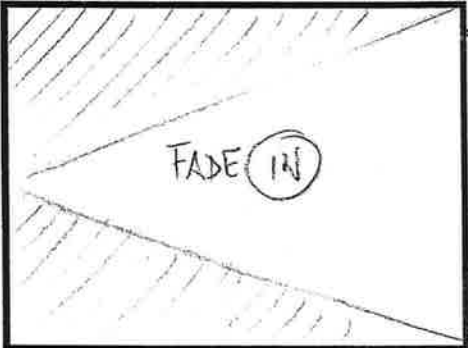

ACTION

DIALOGUES

TECHNIQUE

scène	Cam . reu	Time
1 1/3		OL

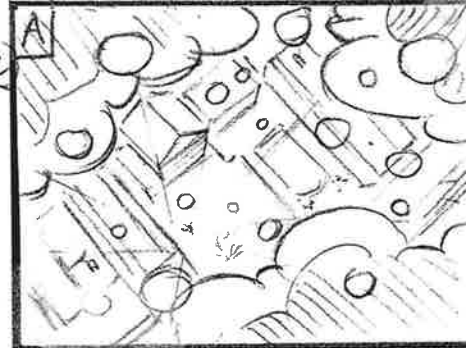

EXT. ECOLE - JOUR - NEIGE  
VUE PLONGEANTE  
NUAGES EN OL

scène	Cam . reu	Time
2/3		



TRK IN A → B  
+ CAM S'ABAISSÉ  
OL TOITS + CHEN + FUMÉE  
IN

1 BG (VO, EXCITED)  
It was the day before Christmas

scène	Cam . reu	Time
3/3		

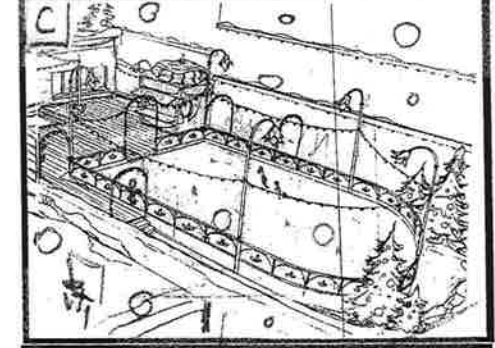

TRK IN B → C  
OL TOITS SLIDE OUT  
HU

### ELLIPSANIME



# #CZ

## EPISODE : BEST XMAS EVER



	PAGE
	2

scène	Cam . reu
2	

Time

scène	Cam . reu	Time

scène	Cam . reu	Time

PAN DOWN  
A → B .

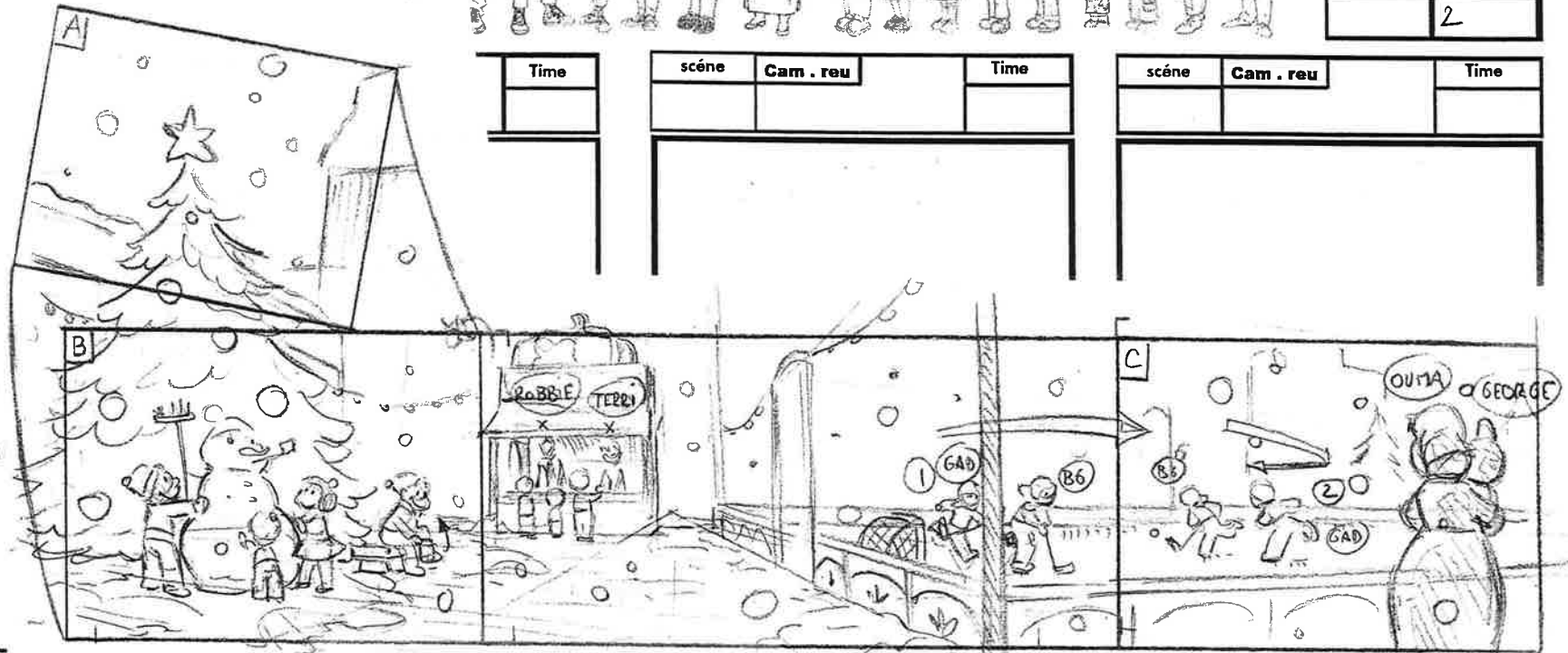

ACTION

DIALOGUES

TECHNIQUE

H.U



PAN B → C

the day of our Championship hockey game.

AND



### ELLIPSANIME

# BIG #CZ

EPISODE : BEST XMAS EVER



	PAGE
	3

scène	Cam . reu	Time
3		

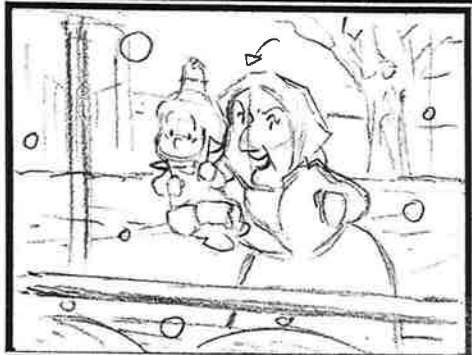

scène	Cam . reu	Time



scène	Cam . reu	Time
4		



scène	Cam . reu	Time
5		



ACTION

DIALOGUES

TECHNIQUE

2 OUMA  
Breakaway,

yes,

CYCLE ANIM. PAN B6

CYCLE ANIM.

**ELLIPSANIME**

# BIG #CZ

EPISODE : BEST XMAS EVER



	PAGE
	4

scène	Cam . reu	Time
6 1/4		

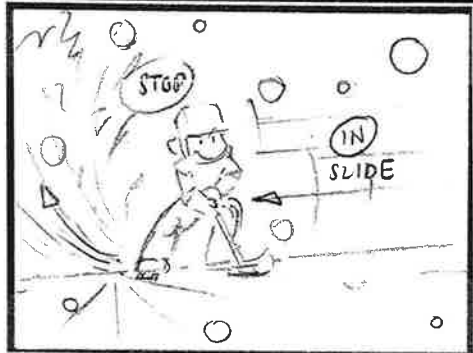

GUDULE (IN) EN DERAPANT  
SHIFT PAN FOLLOW

ACTION

DIALOGUES

TECHNIQUE

SFX BRUIT DE  
DERAPAGE

scène	Cam . reu	Time
4/4		

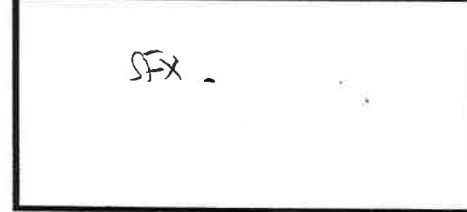
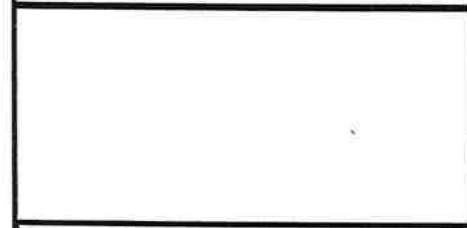
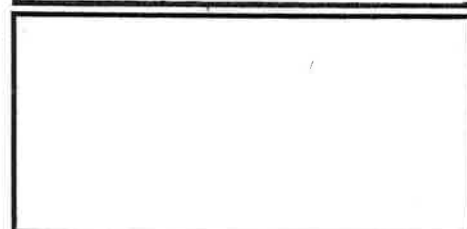

SFX .

scène	Cam . reu	Time
3/4		

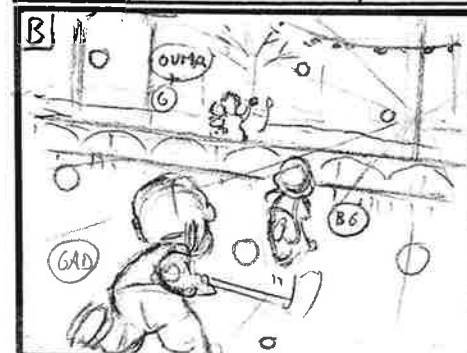

LA CAMERA PASSE DERRIERE  
(B6) ET (GAD)  
ET L'ELEVE. CAM 130°

go for it!

scène	Cam . reu	Time
4/4		

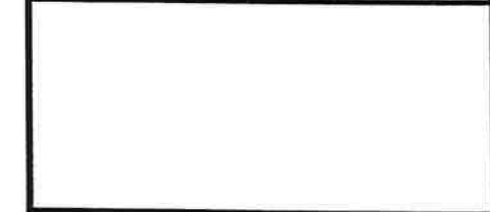
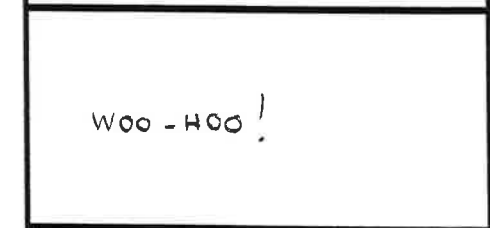
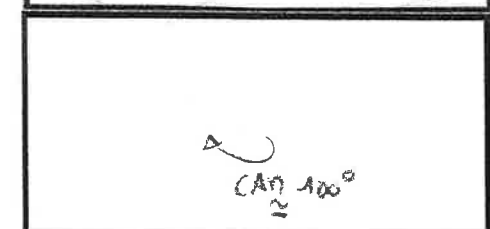
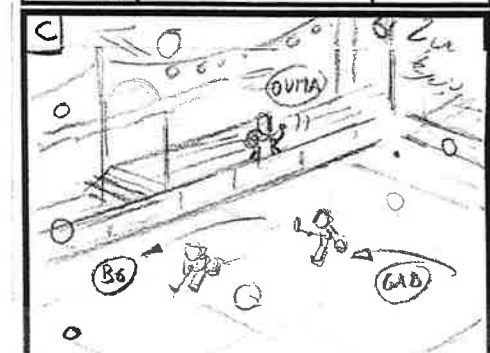

WOO - HOO !

**ELLIPSANIME**

# BIG

# #CZ

## EPISODE : BEST XMAS EVER



	PAGE
	5

scène	Cam . reu	Time
7		



scène	Cam . reu	Time
8		



scène	Cam . reu	Time
9		

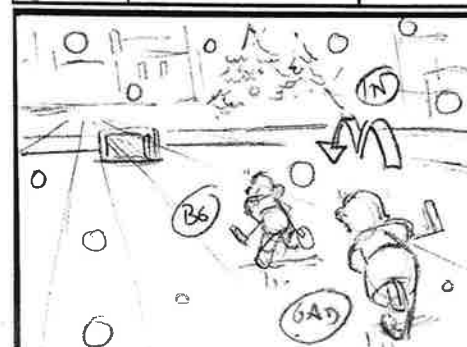

scène	Cam . reu	Time
10		



ACTION

DIALOGUES

TECHNIQUE

3 GEORGE  
Yeah breakaway BG!

woo\_hoo!

PAN B6

### ELLIPSANIME



# #CZ

## EPISODE : BEST XMAS EVER



	PAGE
	6

scène	Cam . reu	Time

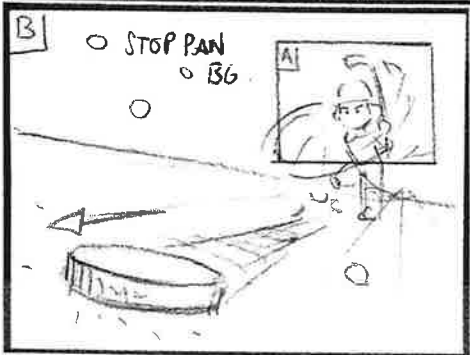

FAST TRK OUT  
FOLLOW/ PALET.

ACTION

DIALOGUES

TECHNIQUE

scène	Cam . reu	Time
11		

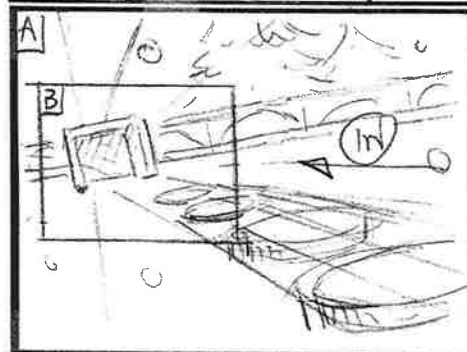

scène	Cam . reu	Time
12		

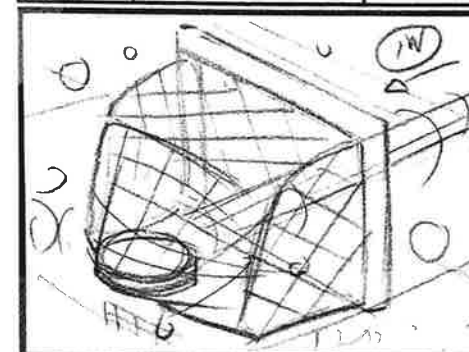

scène	Cam . reu	Time
13 2/5		



1/5



START PAN B6 EN (2)

SFX - BRUIT DE  
PATIN SUR LA GLACE  
EN (2)

### ELLIPSANIME

# BIG #CZ

EPISODE : BEST XMAS EVER



	PAGE
	7

scène	Cam . reu	Time
3/5		

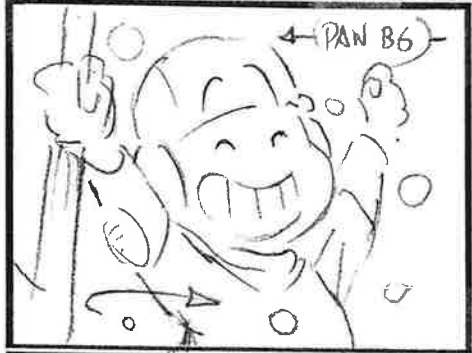

scène	Cam . reu	Time
4/5		



scène	Cam . reu	Time
5/5		



scène	Cam . reu	Time
14		



ACTION

DIALOGUES

TECHNIQUE

SCORE!

SFX

YEAH!

WOO-HOO!

**ELLIPSANIME**

# BIG

# #CZ

## EPISODE : BEST XMAS EVER



	PAGE
	8

scène	Cam . reu	Time



ALBERT LANCE DES  
CONFETTIS.

ACTION

DIALOGUES

TECHNIQUE

scène	Cam . reu	Time
15		



5 GAD  
(wry smile, to Bg)  
Too bad there's no goalie yet.

scène	Cam . reu	Time

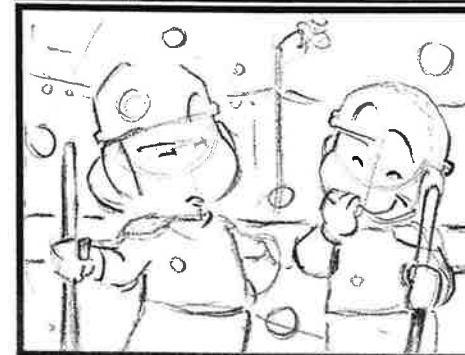

GAD GIGGLES.

scène	Cam . reu	Time



6 BG  
(worried)  
Yeah, I wonder where Alex is?

### ELLIPSANIME



# BIG #CZ

EPISODE : BEST XMAS EVER



	PAGE
	9

scène	Cam . reu	Time
16		

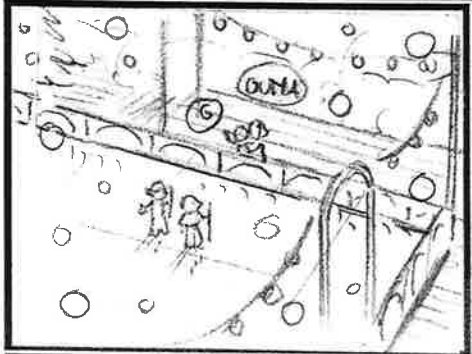

scène	Cam . reu	Time
17		



scène	Cam . reu	Time



scène	Cam . reu	Time
18		



ACTION

DIALOGUES

TECHNIQUE

7 GAD  
I can't believe he'd miss practice on the day of the tournament!

8 BG  
(to George) Go knock on Alex's door,  
George,

tell him to hurry, okay?

GEORGE .  
-GASP!---

**ELLIPSANIME**

# BIG

# #CZ

## EPISODE : BEST XMAS EVER



	PAGE
	10

scène	Cam . reu	Time



ACTION

DIALOGUES

TECHNIQUE

9 GEORGE  
I can't leave the ice,

scène	Cam . reu	Time



coach, Bg. I'm the

scène	Cam . reu	Time
19		

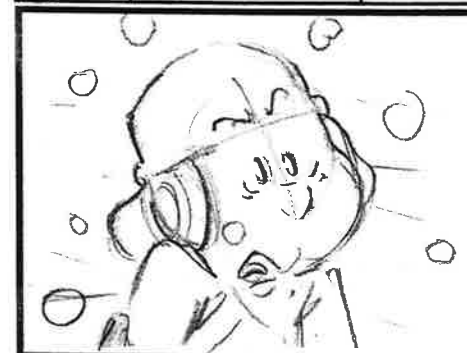

scène	Cam . reu	Time



10 BG  
(eye roll) Assistant coach.

### ELLIPSANIME



# #CZ

## EPISODE : BEST XMAS EVER



	PAGE
	11

scène	Cam . reu	Time
20		



ACTION

DIALOGUES

TECHNIQUE

scène	Cam . reu	Time



ACTION

11 OUMA  
 (to the group at large)  
 I'm sure Alex will be here soon,  
 kids.

TECHNIQUE

scène	Cam . reu	Time
21		



ACTION

This game means the world to  
 him.

TECHNIQUE

scène	Cam . reu	Time

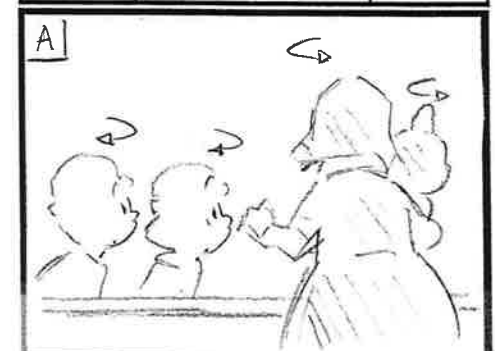

ACTION

DIALOGUES

TECHNIQUE

### ELLIPSANIME



# #CZ

## EPISODE : BEST XMAS EVER



	PAGE
	12

scène	Cam . reu	Time



PAN A → B.

Alex! 12 BG

scène	Cam . reu	Time
(22)		

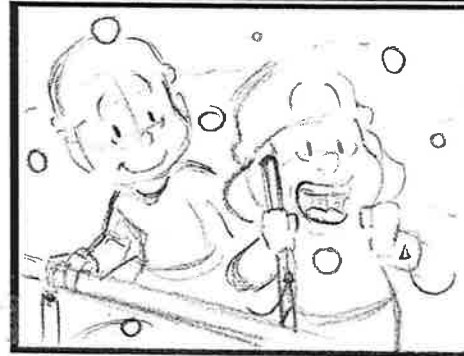

Finally!

scène	Cam . reu	Time



scène	Cam . reu	Time
(23)		

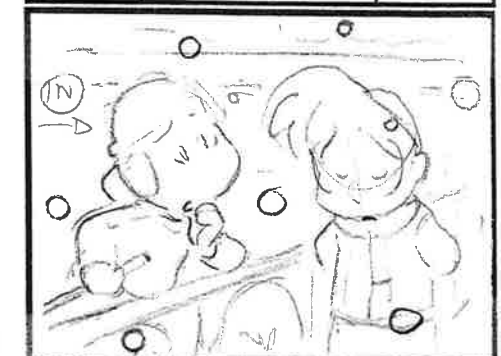

Hey

ACTION

DIALOGUES

TECHNIQUE

### ELLIPSANIME



# #CZ

## EPISODE : BEST XMAS EVER



	PAGE
	13

scène	Cam . reu	Time



scène	Cam . reu	Time



scène	Cam . reu	Time
24		

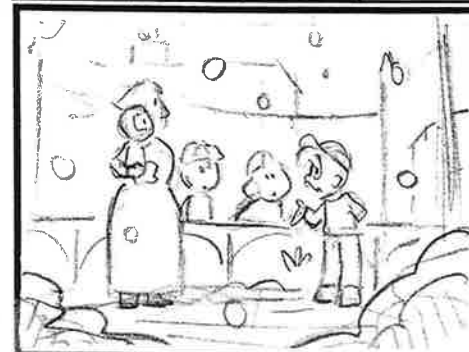

scène	Cam . reu	Time
25		



ACTION

DIALOGUES

TECHNIQUE

what's wrong?

13 ALEX  
I've got some bad news.

My Mom got  
called into work, 'cause of the  
snowstorm,

so Robbie and I are  
going to my Dad's house early.

### ELLIPSANIME

# BIG #CZ

EPISODE : BEST XMAS EVER



	PAGE
	14.

scène	Cam . reu	Time

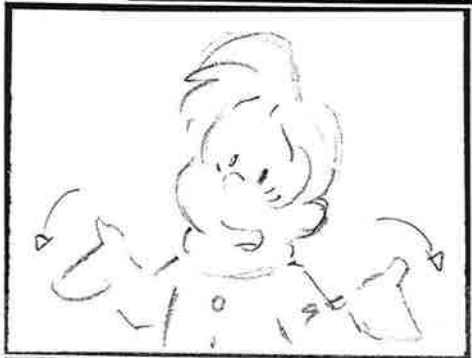

scène	Cam . reu	Time



scène	Cam . reu	Time
26)		



scène	Cam . reu	Time



ACTION

DIALOGUES

TECHNIQUE

We're spending Christmas with *him* this year.

So we have to take the train today at 3 o'clock--

14 BG  
3 o'clock?

5! But the game's not 'til

**ELLIPSA NiME**



# #CZ

## EPISODE : BEST XMAS EVER



	PAGE
	15

scène	Cam . reu	Time
27		



ACTION

DIALOGUES

15 ALEX  
I know, Bg.

TECHNIQUE

scène	Cam . reu	Time



ACTION

DIALOGUES

to miss the game. I'll have

TECHNIQUE

scène	Cam . reu	Time
28		



ACTION

DIALOGUES

TECHNIQUE

scène	Cam . reu	Time

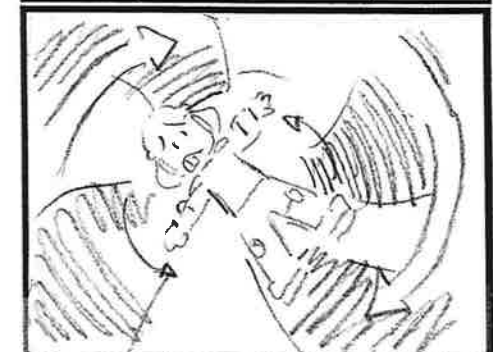

ACTION

DIALOGUES

TECHNIQUE

### ELLIPSANIME

# BIG #CZ

EPISODE : BEST XMAS EVER



	PAGE
	16

scène	Cam . reu	Time
29		



ACTION

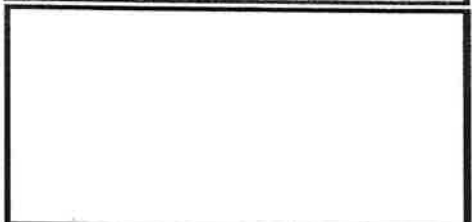

DIALOGUES

16 BG  
You can't miss the game!

TECHNIQUE

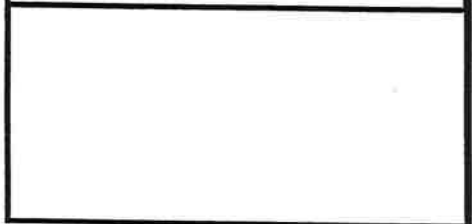

scène	Cam . reu	Time

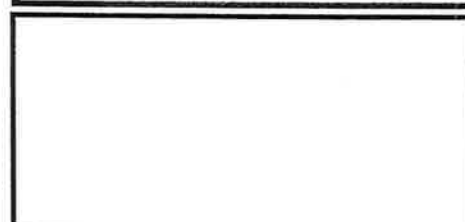

We've been practicing for weeks.

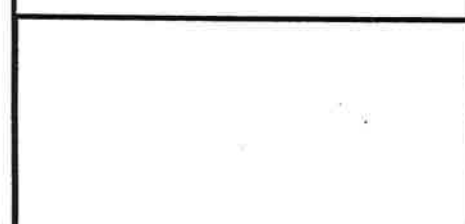

scène	Cam . reu	Time

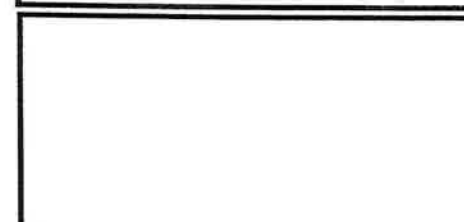
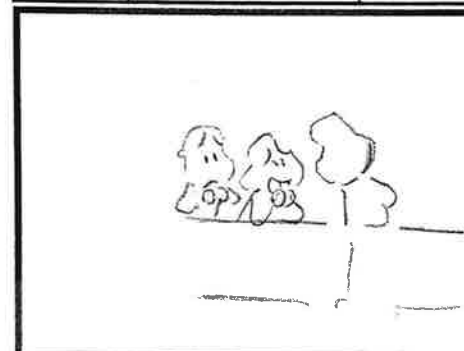

The team can't win without you.

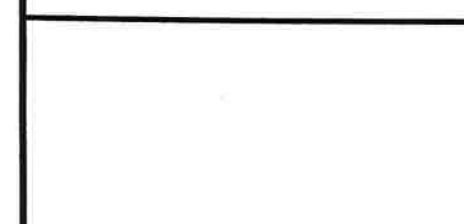

scène	Cam . reu	Time

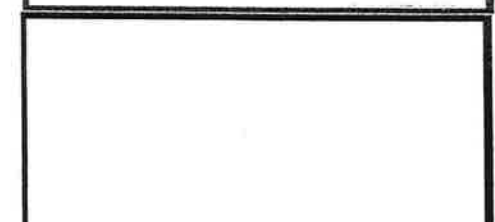

GEORGE.  
YEAH!

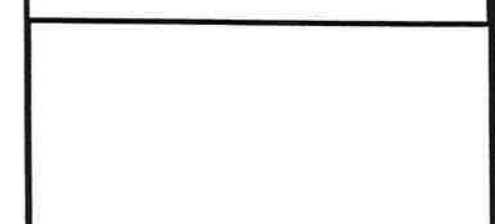

**ELLIPSANIME**



# BIG

# #CZ

## EPISODE : BEST XMAS EVER



	PAGE
	17

scène	Cam . reu	Time
30		



ACTION

DIALOGUES

17 GEORGE  
You're the best goalie ever!

TECHNIQUE

scène	Cam . reu	Time



ACTION

DIALOGUES

18 OUMA  
Children, please,

TECHNIQUE

scène	Cam . reu	Time
31		

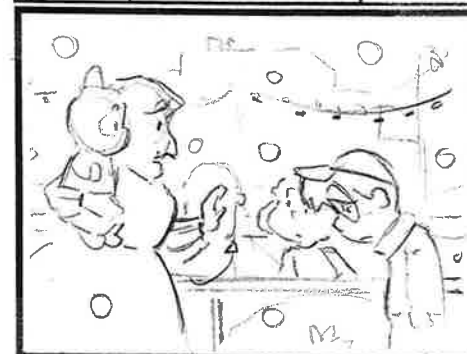

ACTION

DIALOGUES

it's not Alex's fault.

TECHNIQUE

scène	Cam . reu	Time



ACTION

DIALOGUES

19 BG  
Sorry, I know you're upset.

TECHNIQUE

### ELLIPSANIME



# #CZ

## EPISODE : BEST XMAS EVER



	PAGE
	18

scène	Cam . reu	Time
32		

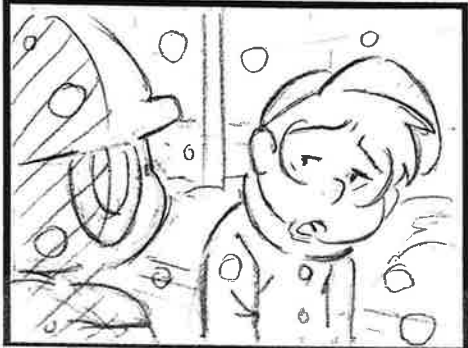

ACTION

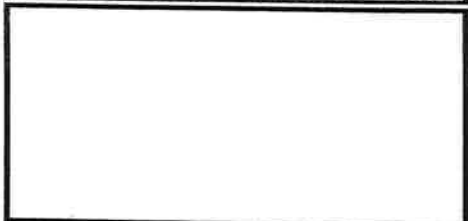

DIALOGUES

20 ALEX  
Well of course I am.

TECHNIQUE



scène	Cam . reu	Time

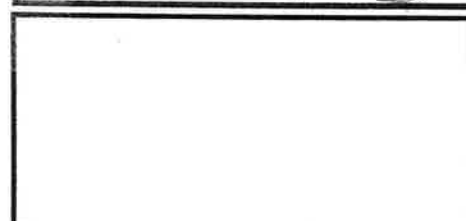

as badly as you do. I want to win

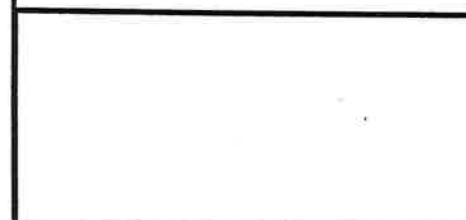

scène	Cam . reu	Time

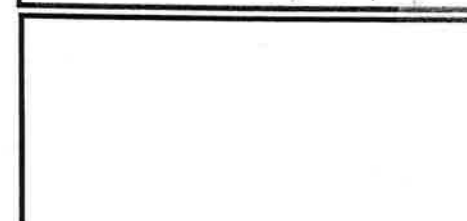

But since the divorce  
we have to divide up  
Christmas

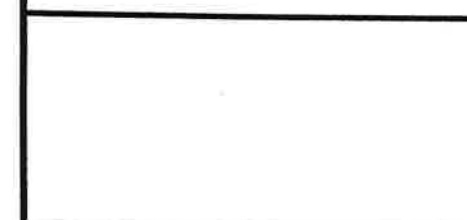

scène	Cam . reu	Time



2  
between my Mom and my Dad,

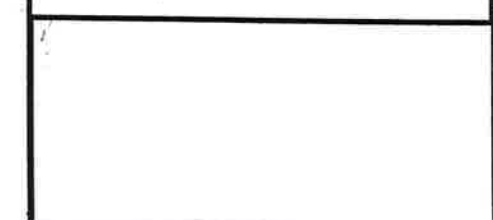

### ELLIPSANIME

# BIG #CZ

EPISODE : BEST XMAS EVER



	PAGE
	19

scène	Cam . reu	Time

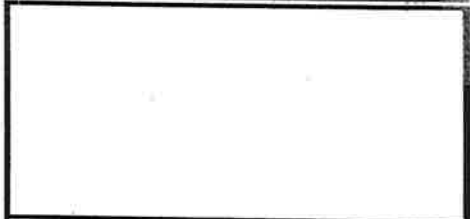

there's nothing I can do.



scène	Cam . reu	Time
33		

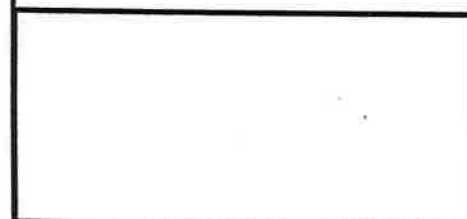
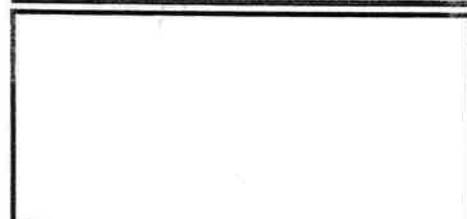

scène	Cam . reu	Time



21 BG  
Maybe there is,

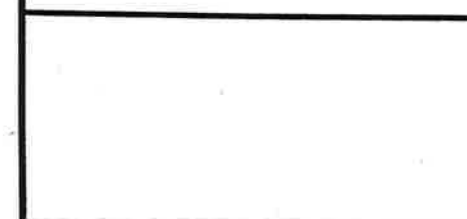

scène	Cam . reu	Time



you can talk to  
Robbie,



ACTION

DIALOGUES

TECHNIQUE

**ELLIPSANIME**



# #CZ

## EPISODE : BEST XMAS EVER



	PAGE
	20

scène	Cam . reu	Time

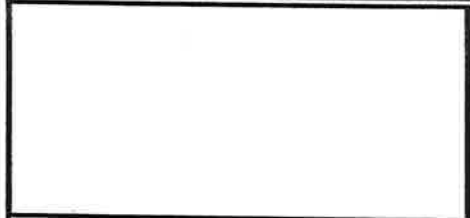

I bet he'll help us.

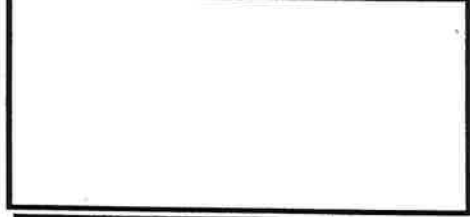

scène	Cam . reu	Time
84		

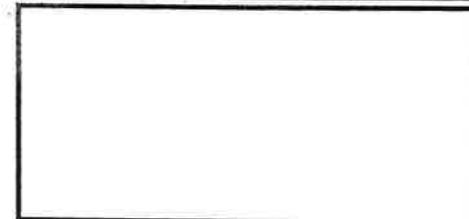
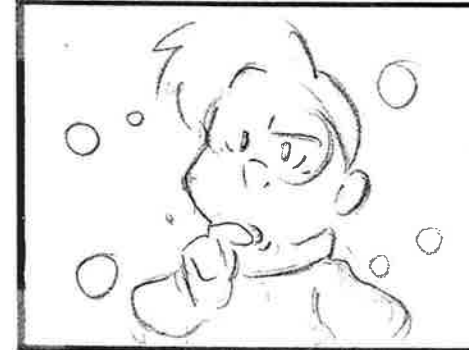

21A ALEX  
I don't know BG...

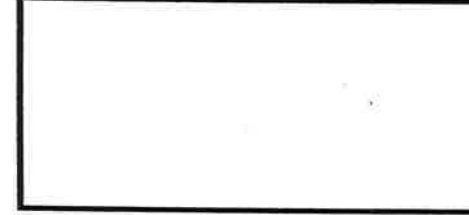

scène	Cam . reu	Time

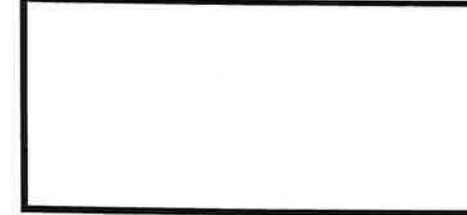
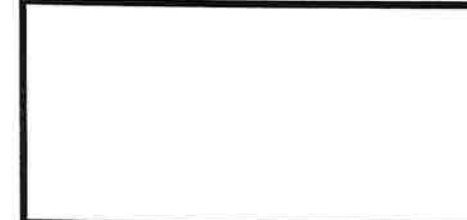
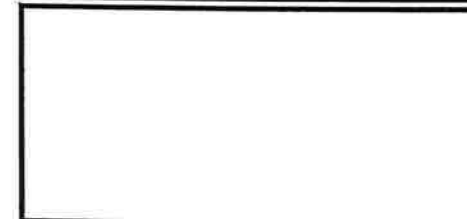
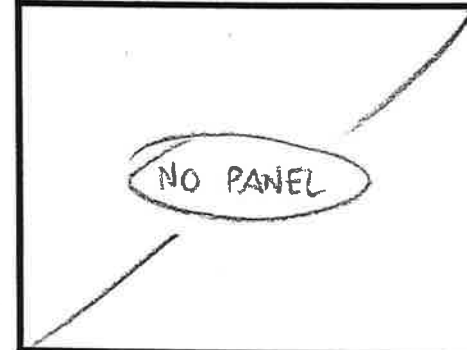

scène	Cam . reu	Time

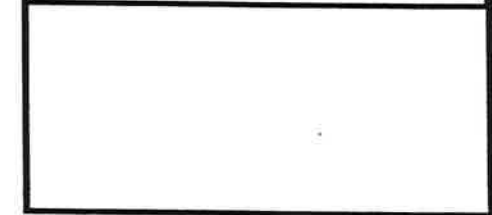

ACTION

DIALOGUES

TECHNIQUE

### ELLIPSANIME



# #CZ

## EPISODE : BEST XMAS EVER



	PAGE
	21

scène	Cam . reu	Time
35		

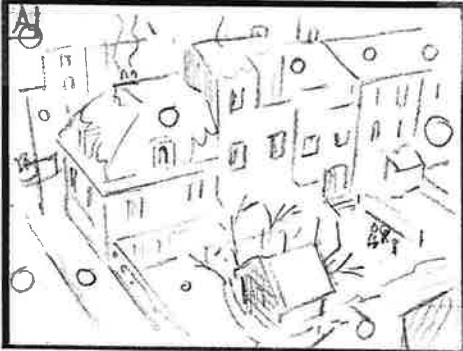

scène	Cam . reu	Time



TRK (IN) A → B.

22 ALEX  
...And I'll miss the game  
completely, Robbie,

scène	Cam . reu	Time
36		

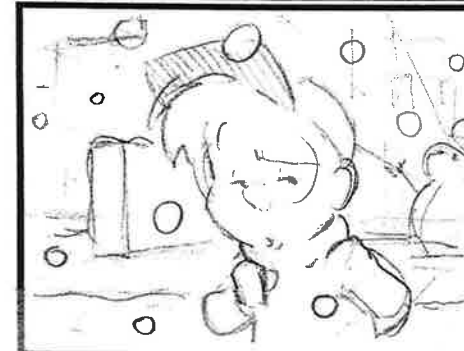

so, um,

scène	Cam . reu	Time



we were  
wondering...

ACTION

DIALOGUES

TECHNIQUE

### ELLIPSANIME



# #CZ

## EPISODE : BEST XMAS EVER



	PAGE
	12

scène	Cam . reu	Time

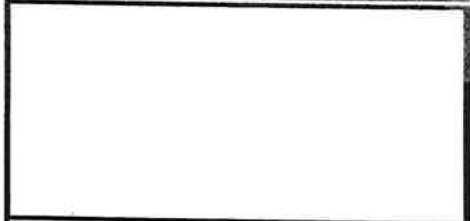

can we go on a later train to Dad's?



scène	Cam . reu	Time
37		

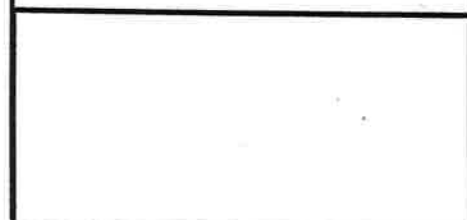
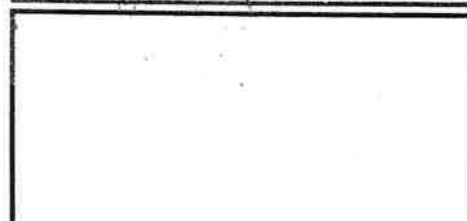

scène	Cam . reu	Time



24 ROBBIE  
Sorry, there is no later train,

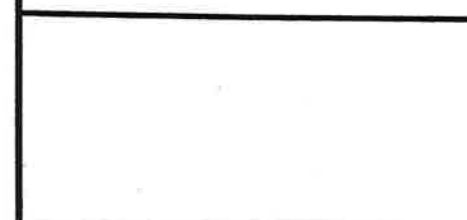

scène	Cam . reu	Time



that's the last one today.

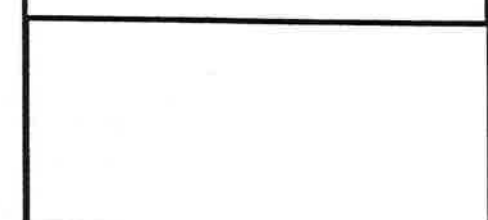

ACTION

DIALOGUES

TECHNIQUE

### ELLIPSANIME

# BIG

# #CZ

## EPISODE : BEST XMAS EVER



	PAGE
	23

scène	Cam . reu	Time
38		

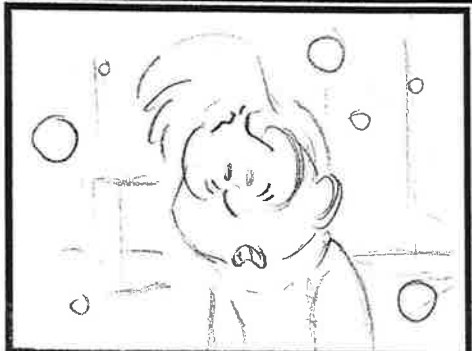

scène	Cam . reu	Time



scène	Cam . reu	Time
39		



scène	Cam . reu	Time

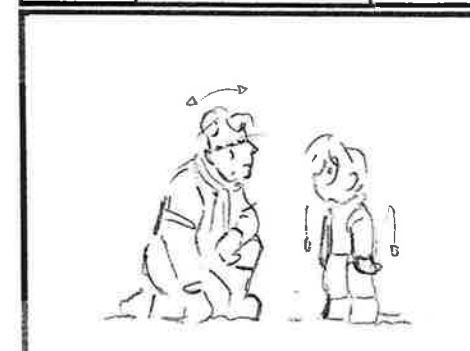

ACTION

DIALOGUES

TECHNIQUE

25 ALEX  
Well

can we leave tomorrow, then?

26 ROBBIE  
I don't think so Alex.

### ELLIPSANIME

# BIG #CZ

EPISODE : BEST XMAS EVER



	PAGE
	24

scène	Cam . reu	Time



ACTION

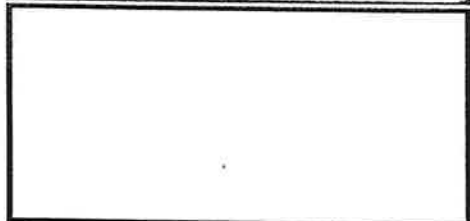

DIALOGUES

Mom's working the late shift tonight.

TECHNIQUE

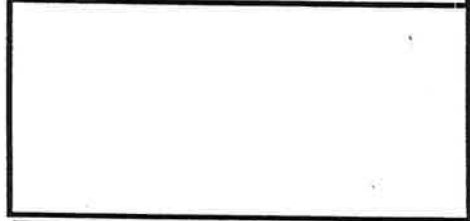

scène	Cam . reu	Time

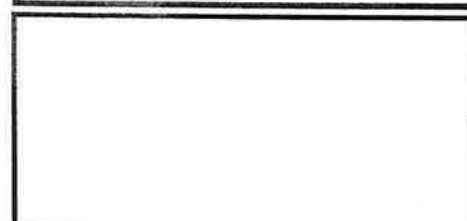

and she has to work tomorrow too.

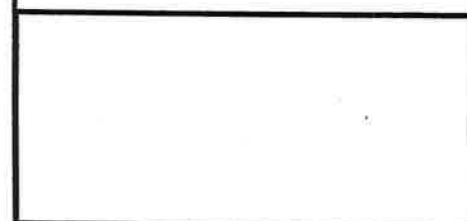

scène	Cam . reu	Time
(40)		

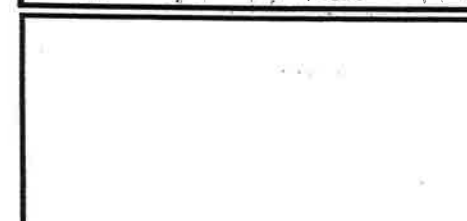

She really wants us at Dad's,

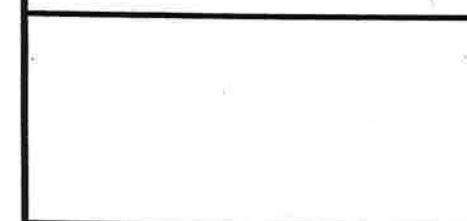

scène	Cam . reu	Time
(41)		



I don't want to upset her.

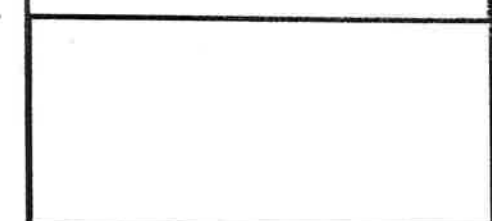

**ELLIPSANIME**





# #CZ

## EPISODE : BEST XMAS EVER



	PAGE
	25

scène	Cam . reu	Time

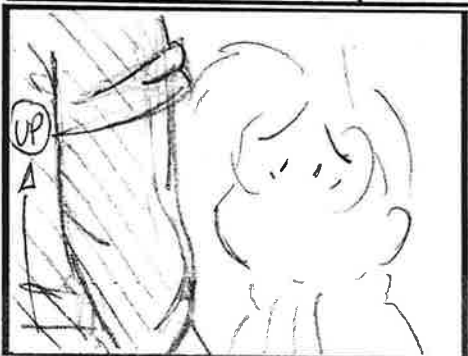

ROBBIE (UP)

ACTION

27 ROBBIE  
Besides,

DIALOGUES

TECHNIQUE

scène	Cam . reu	Time
(42)		



Dad's looking forward to  
having us a day early.

He's got a  
big dinner planned. (Robbie pats

okay? ALEX?

scène	Cam . reu	Time



okay? ALEX?

okay? ALEX?

okay? ALEX?

scène	Cam . reu	Time



okay? ALEX?

okay? ALEX?

okay? ALEX?

### ELLIPSANIME



# #CZ

## EPISODE : BEST XMAS EVER



	PAGE
	26

scène	Cam . reu	Time



scène	Cam . reu	Time

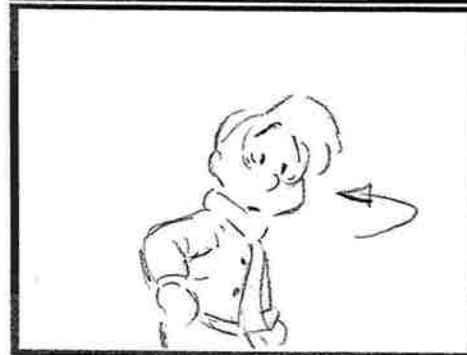

scène	Cam . reu	Time
43		



scène	Cam . reu	Time



ACTION

DIALOGUES

TECHNIQUE

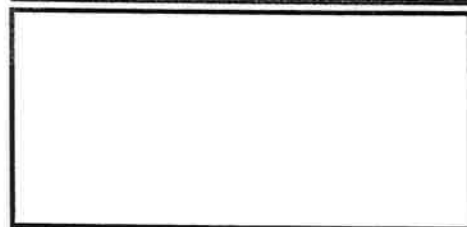

28 BG (OFF)  
(explodes)

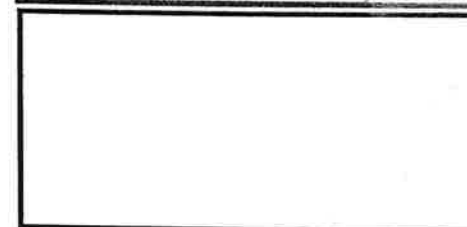

It isn't fair!

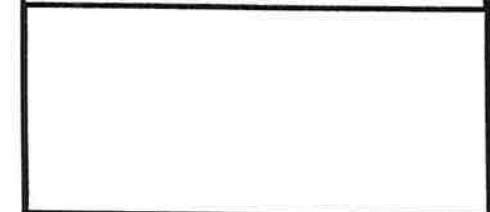
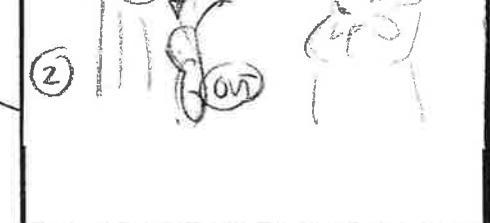
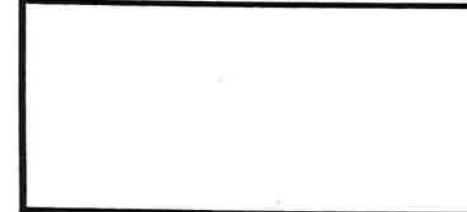

### ELLIPSANIME

# BIG

# #CZ

## EPISODE : BEST XMAS EVER



	PAGE
	27

scène	Cam . reu	Time
44		



scène	Cam . reu	Time
45		

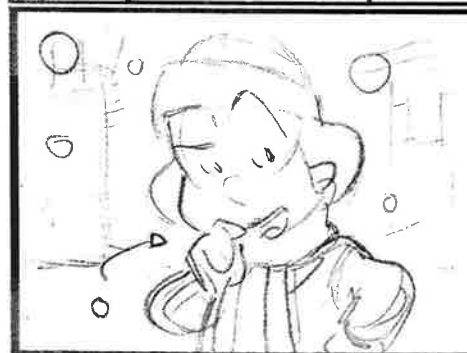

scène	Cam . reu	Time



scène	Cam . reu	Time



ACTION

DIALOGUES

TECHNIQUE

29 ALEX  
(obviously torn)  
I know, but I can't hurt my Dad's feelings.

30 BG  
I have an idea.

What if something happened, and you missed the train

'accidentally'??

### ELLIPSANIME

# BIG

# #CZ

## EPISODE : BEST XMAS EVER



	PAGE
	28

scène	Cam . reu	Time
46		



ACTION

DIALOGUES

No one would be hurt then, and you could play in the game.

TECHNIQUE

scène	Cam . reu	Time



ACTION

DIALOGUES

31 GAD  
I don't know, Bg, sounds like a bad idea.

TECHNIQUE

scène	Cam . reu	Time



ACTION

DIALOGUES

32 BG  
(heated)  
Yeah, but so is losing the game!

TECHNIQUE

scène	Cam . reu	Time



ACTION

DIALOGUES

TECHNIQUE

### ELLIPSANIME

# BIG

# #CZ

## EPISODE : BEST XMAS EVER



	PAGE
	29

scène	Cam . reu	Time

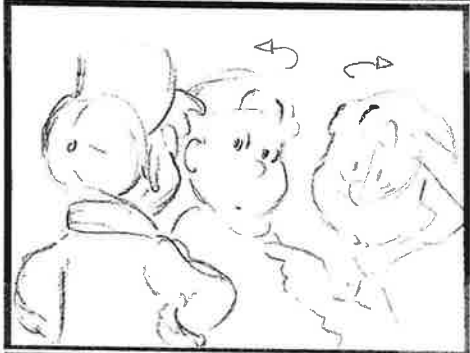

ACTION

DIALOGUES

33 ALEX  
(Beat)  
okay,

TECHNIQUE

scène	Cam . reu	Time
47		



ACTION

DIALOGUES

just for arguments sake,  
what's your plan?

TECHNIQUE

scène	Cam . reu	Time
48		

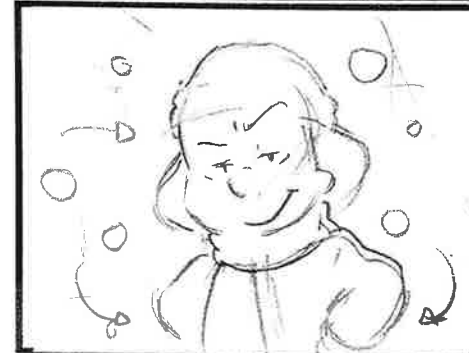

ACTION

DIALOGUES

Well... 33A BG

TECHNIQUE

scène	Cam . reu	Time

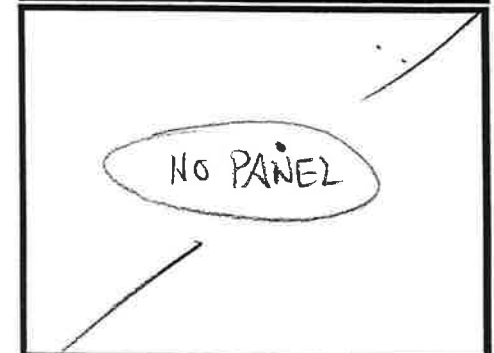

ACTION

DIALOGUES

TECHNIQUE

### ELLIPSANIME



# #CZ

## EPISODE : BEST XMAS EVER



	PAGE
	30

scène	Cam . reu	Time
(49)		



scène	Cam . reu	Time
(50)		



⚠ A PARTIR DE CETTE SCENE, ALEX A DES TACHES ROUGES SUR LE VISAGE → FIN DU BOARD

34 GAD  
Chickenpox??

scène	Cam . reu	Time
(51)		



This is ridiculous.

scène	Cam . reu	Time



35 BG  
No it's not.

ACTION

DIALOGUES

TECHNIQUE

### ELLIPSANIME



#CZ

EPISODE : BEST XMAS EVER



	PAGE
	31

scène	Cam . reu	Time



ACTION

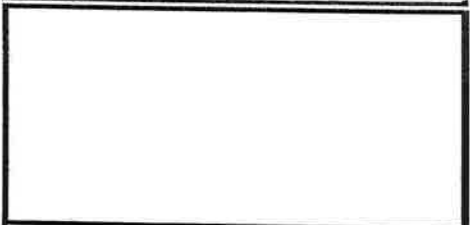

DIALOGUES

If Alex is sick, he can't take the train.

TECHNIQUE

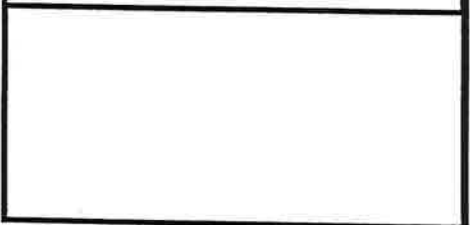

scène	Cam . reu	Time
52		

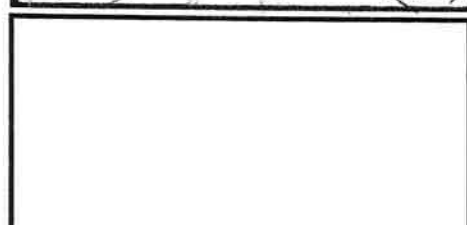

36 GAD  
Only George would think those lipstick dots are real!

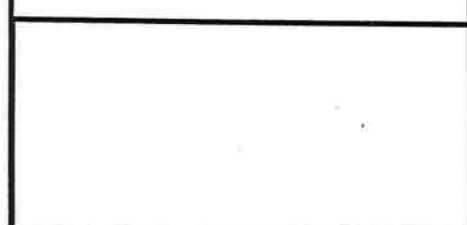

scène	Cam . reu	Time
53		

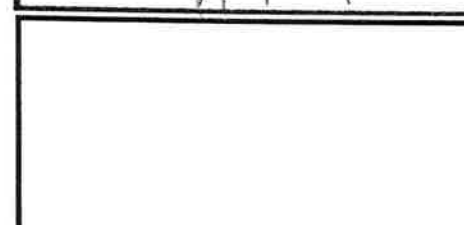

37 BG  
(insulted)  
That's not true.

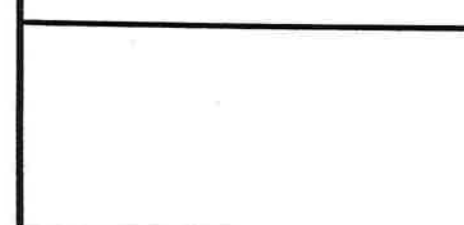

scène	Cam . reu	Time

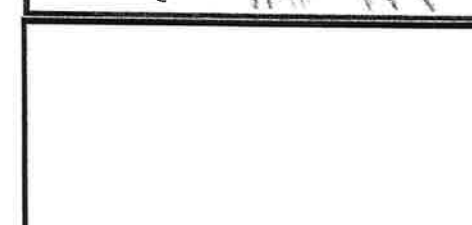

(brandishing the tube) It's Mom's 8-hour smudge-resistant lipstick!

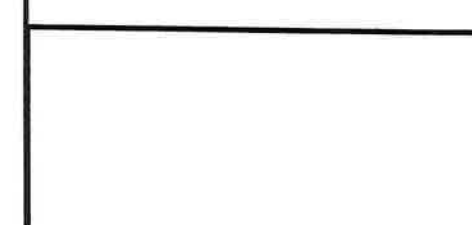

ELLIPSANIME



# #CZ

## EPISODE : BEST XMAS EVER



	PAGE
	32

scène	Cam . reu	Time
54		



ACTION

DIALOGUES

38 GAD  
Oh brother.

TECHNIQUE

scène	Cam . reu	Time



ACTION

DIALOGUES

Hey, aren't you  
forgetting something?

TECHNIQUE

scène	Cam . reu	Time
55		

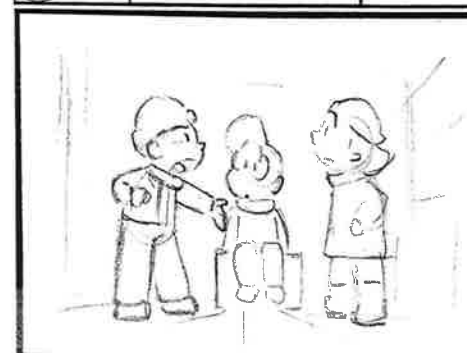

ACTION

DIALOGUES

If Alex is  
'sick', he can't play hockey  
either,

TECHNIQUE

scène	Cam . reu	Time



ACTION

DIALOGUES

Ouma wouldn't let him near  
the other kids.

TECHNIQUE

### ELLIPSANIME



# BIG #CZ

EPISODE : BEST XMAS EVER



	PAGE
	33

scène	Cam . reu	Time
56		



ACTION

DIALOGUES

39 BG  
(big inhale) ah..

TECHNIQUE

scène	Cam . reu	Time



ACTION

DIALOGUES

True..

TECHNIQUE

scène	Cam . reu	Time



PAN A → B

DIALOGUES

40 ALEX  
(disappointed)  
...what do we do now?

TECHNIQUE

scène	Cam . reu	Time



ACTION

DIALOGUES

TECHNIQUE

**ELLIPSANIME**



# #CZ

## EPISODE : BEST XMAS EVER



	PAGE
	34

scène	Cam . reu	Time
57		



ACTION

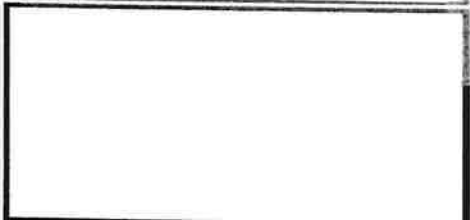

DIALOGUES

Well 41 BG

TECHNIQUE



scène	Cam . reu	Time



first we clean off your 'chickenpox'.

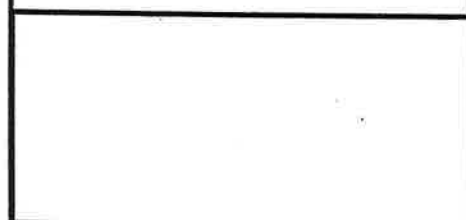

scène	Cam . reu	Time
58		

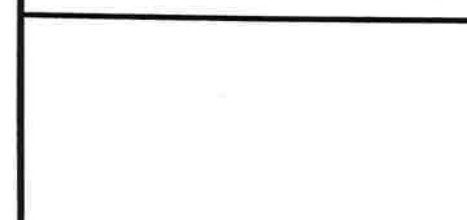
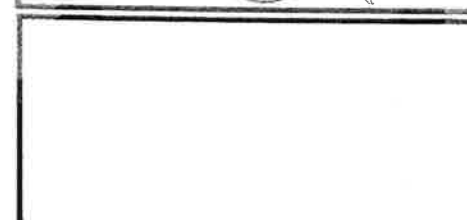

scène	Cam . reu	Time

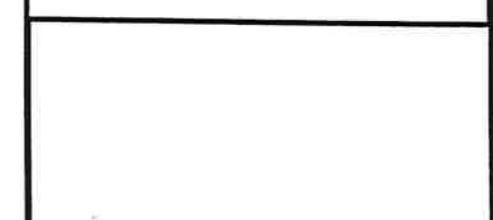
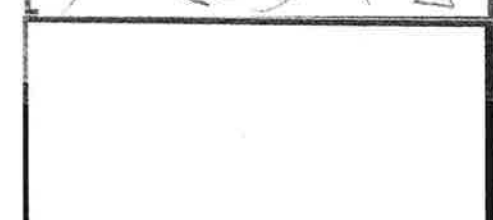

### ELLIPSANIME

# BIG

# #CZ

## EPISODE : BEST XMAS EVER



	PAGE
	35

scène	Cam . reu	Time

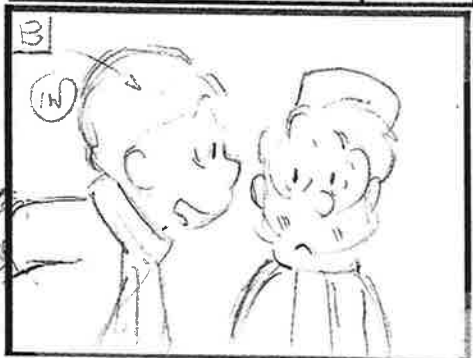

ACTION

DIALOGUES

TECHNIQUE

42 GAD  
Uh-oh,

scène	Cam . reu	Time



'smudge-free' was RIGHT.

scène	Cam . reu	Time
59		



43 ALEX (OFF)  
(alarmed, to Gad)  
What do you mean?

scène	Cam . reu	Time



### ELLIPSANIME



# #CZ

## EPISODE : BEST XMAS EVER



	PAGE
	36

scène	Cam . reu	Time
60		

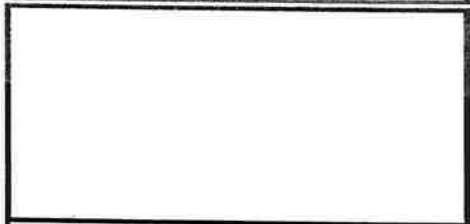

done, Bg??                      What have you



scène	Cam . reu	Time

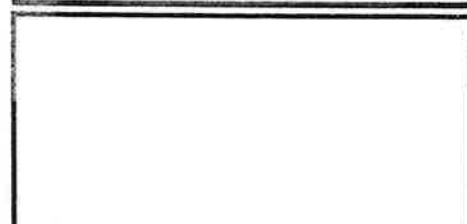

44 BG  
Nothing, don't worry,

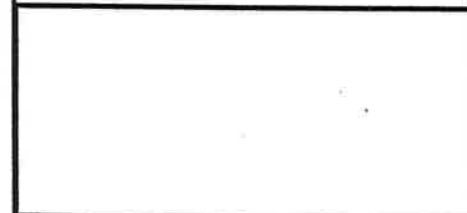

scène	Cam . reu	Time

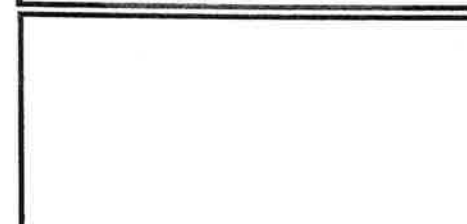
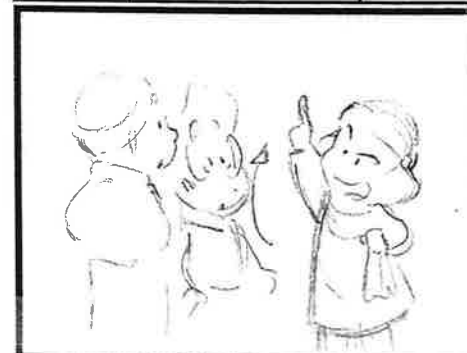

Plan 'B'.                                      it's time for

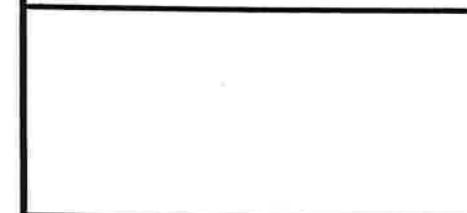

scène	Cam . reu	Time

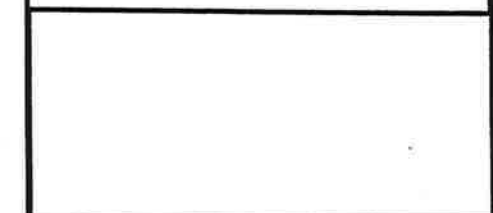

ACTION

DIALOGUES

TECHNIQUE

### ELLIPSANIME



# #CZ

## EPISODE : BEST XMAS EVER



	PAGE
	37

scène	Cam . reu	Time



ACTION

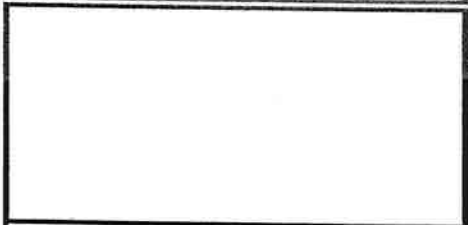

DIALOGUES

45 ALEX  
Plan 'B'?

TECHNIQUE

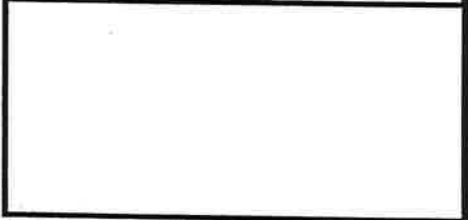

scène	Cam . reu	Time
61		

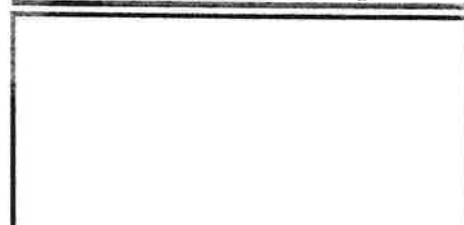

46 BG  
(beaming)  
You can't go on a trip without  
luggage.

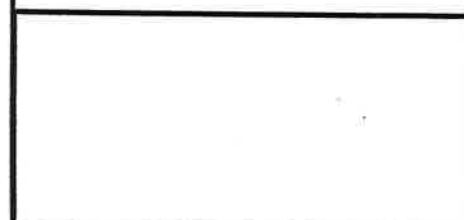

scène	Cam . reu	Time
62		

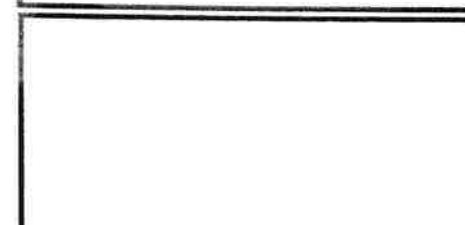
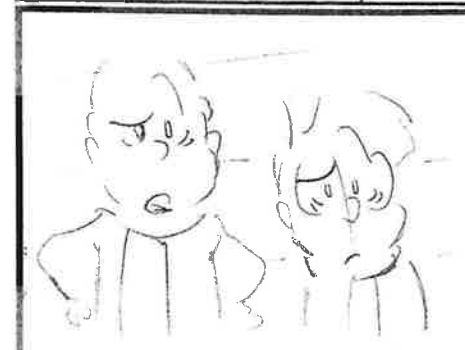

46A GAD  
Luggage?...

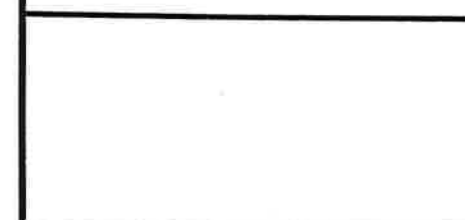

scène	Cam . reu	Time

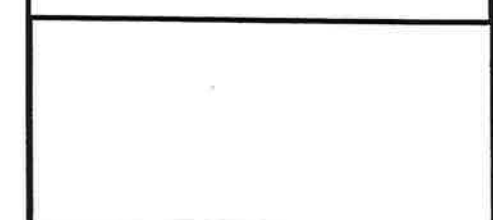
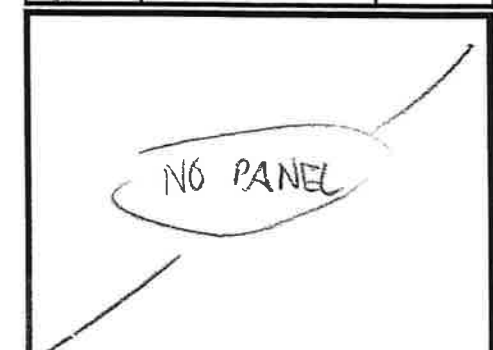

### ELLIPSANIME



# #CZ

## EPISODE : BEST XMAS EVER



	PAGE
	38

scène	Cam . reu	Time
63		



EXT. MAISON D'ALEX.

ACTION

DIALOGUES

47 BG  
Okay,

TECHNIQUE

scène	Cam . reu	Time
64		



coast is clear.

scène	Cam . reu	Time
65		

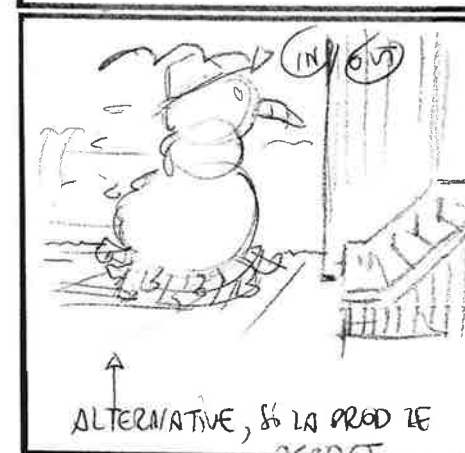
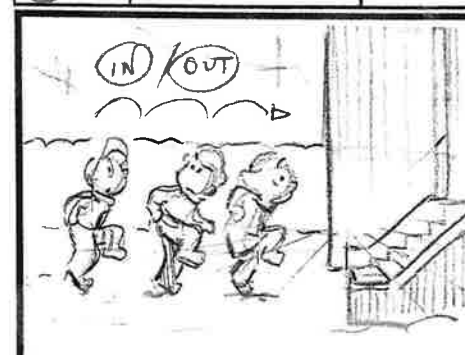

scène	Cam . reu	Time



### ELLIPSANIME



# #CZ

## EPISODE : BEST XMAS EVER



	PAGE
	39

scène	Cam . reu	Time
66		

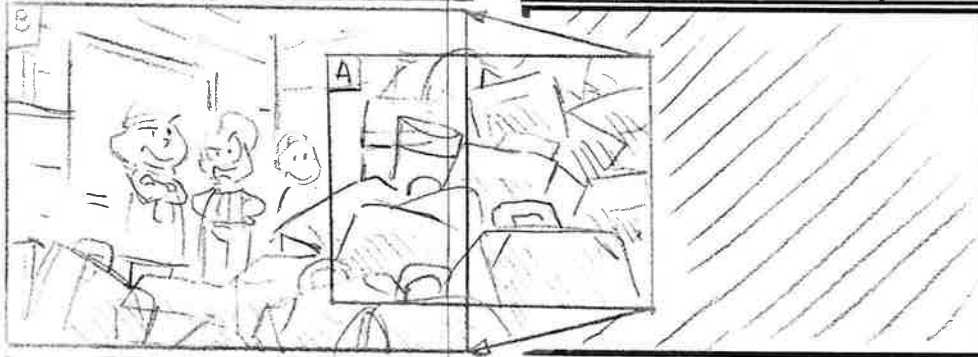

scène	Cam . reu	Time

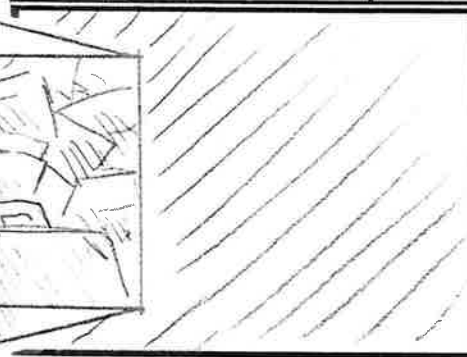

scène	Cam . reu	Time



scène	Cam . reu	Time
67		



ACTION

DIALOGUES

TECHNIQUE

48 ALEX  
(triumphant)  
There, no bags left in my house

period.

49 BG  
No bags, no trip!

### ELLIPSANIME



# #CZ

## EPISODE : BEST XMAS EVER



	PAGE
	40

scène	Cam . reu	Time



ACTION

DIALOGUES

TECHNIQUE

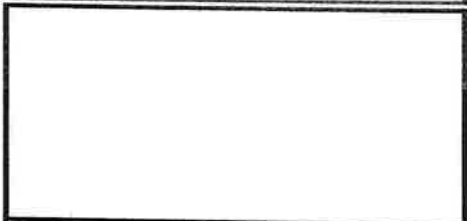

(to Alex) This time, you're sure to stay home!



scène	Cam . reu	Time
68		

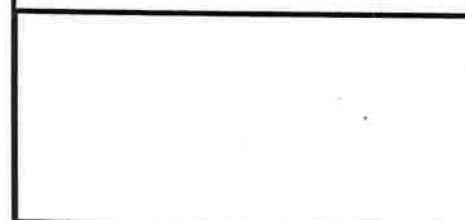
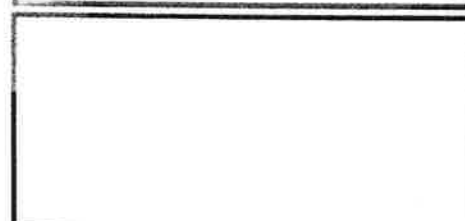

scène	Cam . reu	Time

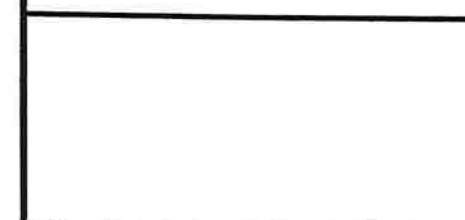
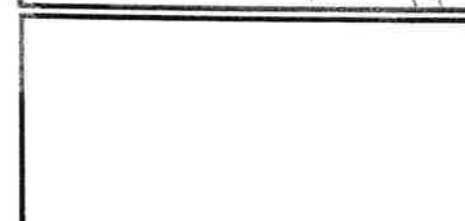

scène	Cam . reu	Time
69		

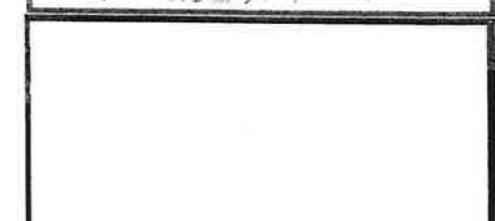
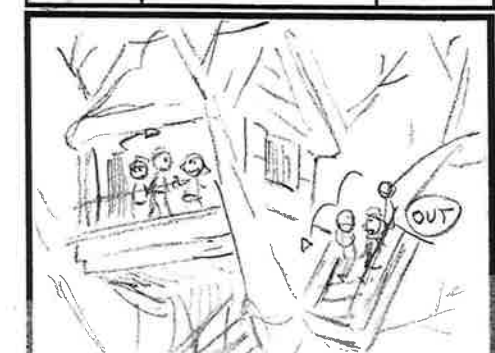

50 BG  
Wanna go to my place, and have lunch? Then we can go practice.

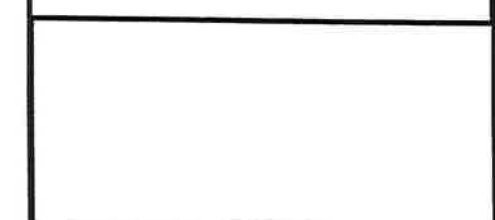

### ELLIPSANIME



# BIG

# #CZ

## EPISODE : BEST XMAS EVER



	PAGE
	41

scène	Cam . reu	Time
70		



TRK (IN) A → B

scène	Cam . reu	Time
71		

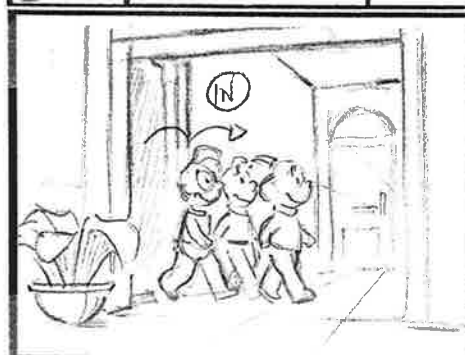

scène	Cam . reu	Time

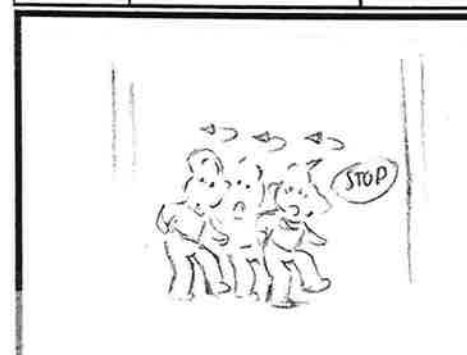

TRIO -  
GASP

scène	Cam . reu	Time
72		



ROBBIE ADMIRE LA  
GUILLANDE ELECTRIQUE -  
TRK (IN) A → B -

ACTION

DIALOGUES

TECHNIQUE

### ELLIPSANIME



# #CZ

## EPISODE : BEST XMAS EVER



	PAGE
	42

scène	Cam . reu	Time
73		

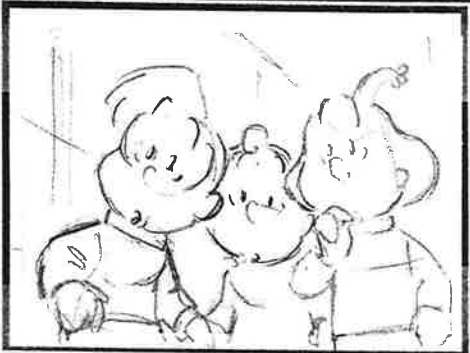

ACTION

DIALOGUES

TECHNIQUE

51 ALEX  
(suspicious)  
Now what's going on?

scène	Cam . reu	Time
74		



52 BG  
Hey Robbie,

scène	Cam . reu	Time



what are you doing?

scène	Cam . reu	Time



53 ROBBIE  
(puzzled)  
Borrowing some luggage,

### ELLIPSANIME

# BIG

# #CZ

## EPISODE : BEST XMAS EVER



	PAGE
	43

scène	Cam . reu	Time
75		



ACTION

DIALOGUES

I can't seem to find any of ours.

TECHNIQUE

scène	Cam . reu	Time



TRICUT

scène	Cam . reu	Time
76		



54 MOM  
There.

scène	Cam . reu	Time
77		



CUT PAGE

2  
That should do the job.

### ELLIPSANIME



#CZ

EPISODE : BEST XMAS EVER



	PAGE
	44

scène	Cam . reu	Time
78		



ACTION

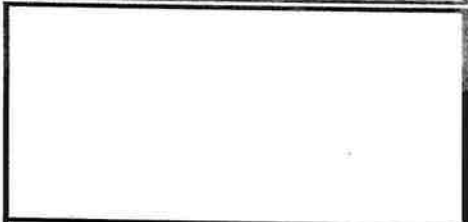

DIALOGUES

55 ROBBIE  
I'll say. Thanks.

TECHNIQUE



scène	Cam . reu	Time

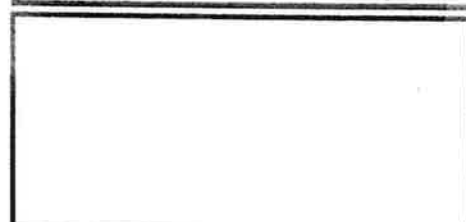

Come on, bud, we have to pack,

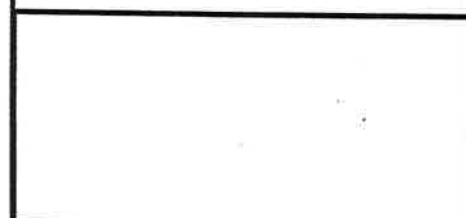

scène	Cam . reu	Time



really soon now. we leave



scène	Cam . reu	Time

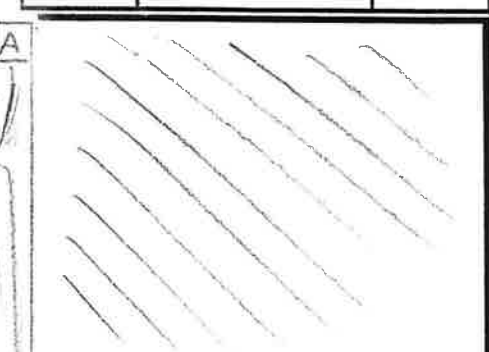

PAN A -> B -

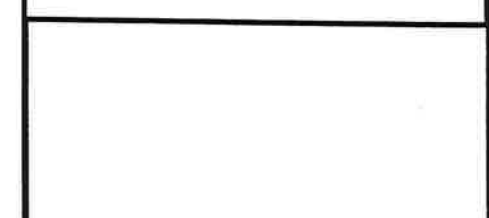

ELLIPSANIME



# #CZ

## EPISODE : BEST XMAS EVER



	PAGE
	45

scène	Cam . reu	Time
79		

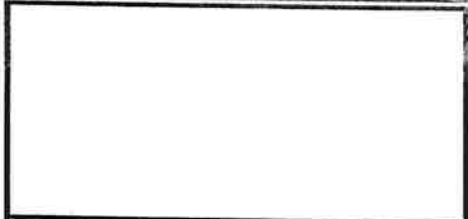

56 GAD  
Well that's that. Alex is going,

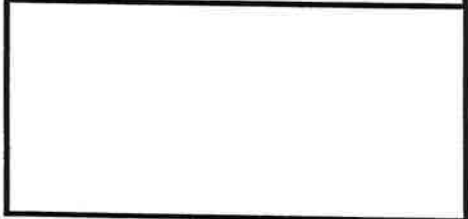

scène	Cam . reu	Time

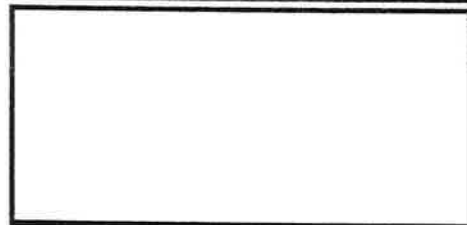
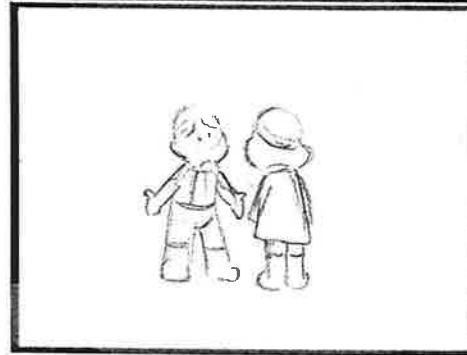

whether we like it or not.



scène	Cam . reu	Time
80		

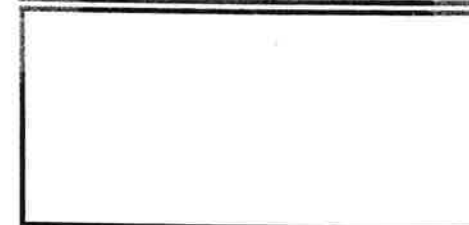

57 BG  
(stunned)  
...But what about the game?

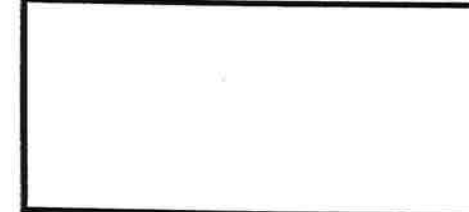

scène	Cam . reu	Time
81		

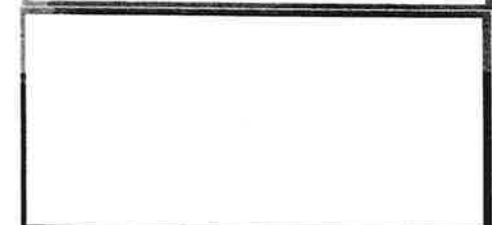
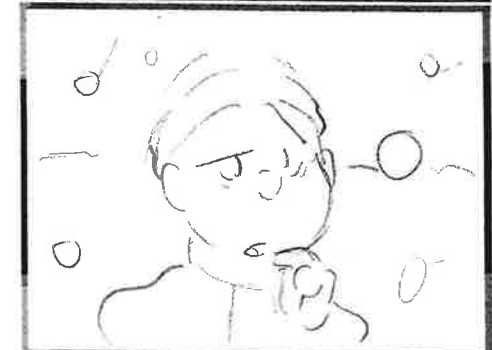

59 GAD  
I'll go tell Ouma we need a new goalie.

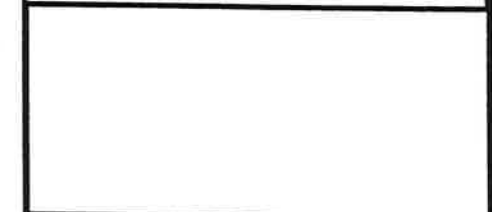

ACTION

DIALOGUES

TECHNIQUE

### ELLIPSANIME

# BIG #CZ

EPISODE : BEST XMAS EVER



	PAGE
	46

scène	Cam . reu	Time



ACTION

DIALOGUES

Maybe Billy can do it.

TECHNIQUE

scène	Cam . reu	Time
82		



ACTION

DIALOGUES

60 BG  
(outraged )  
Billy?

TECHNIQUE

scène	Cam . reu	Time



ACTION

DIALOGUES

He can barely stay on his skates!

TECHNIQUE

scène	Cam . reu	Time
83		



ACTION

→ SHIFT .

DIALOGUES

51 GAD  
Well at least he'd fill the net up.

TECHNIQUE

**ELLIPSANIME**



# #CZ

## EPISODE : BEST XMAS EVER



	PAGE
	47

scène	Cam . reu	Time



TEK (IN) B → C

62 BG (VO)  
...I had to talk to Robbie one more time.

TECHNIQUE

scène	Cam . reu	Time



scène	Cam . reu	Time



scène	Cam . reu	Time



### ELLIPSANiME



# #CZ

## EPISODE : BEST XMAS EVER



	PAGE
	48

scène	Cam . reu	Time
84		



scène	Cam . reu	Time

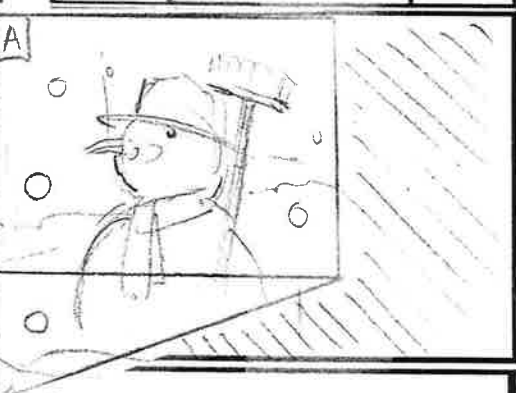

scène	Cam . reu	Time
85		

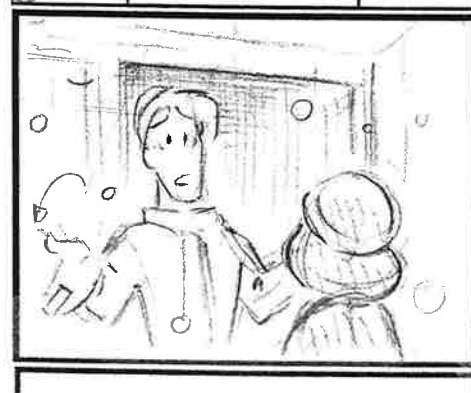

scène	Cam . reu	Time
86		

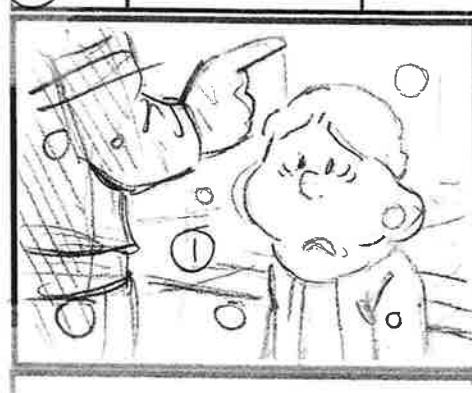

ACTION

PAN A->B

DIALOGUES

64 ROBBIE  
 (in a rush, distracted)  
 Sorry, Bg, I'm in a rush,

TECHNIQUE

Alex is still packing  
 and we need to leave  
 right away,

2

if we're gonna have  
 time to find parking--

### ELLIPSANIME





#CZ

EPISODE : BEST XMAS EVER



	PAGE
	49

scène	Cam . reu	Time
87		

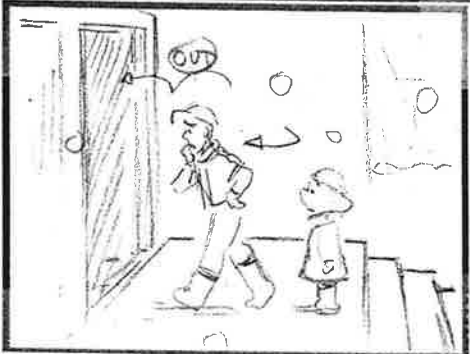

ACTION

DIALOGUES

TECHNIQUE

65 ROBBIE  
...Now where'd I leave my keys??

scène	Cam . reu	Time



ACTION

DIALOGUES

TECHNIQUE

scène	Cam . reu	Time
88		



ACTION

DIALOGUES

TECHNIQUE

scène	Cam . reu	Time



ACTION

DIALOGUES

TECHNIQUE

B6 TRÉBUCHE

ELLIPSANIME



#CZ

EPISODE : BEST XMAS EVER



	PAGE
	50

scène	Cam . reu	Time



scène	Cam . reu	Time
89		

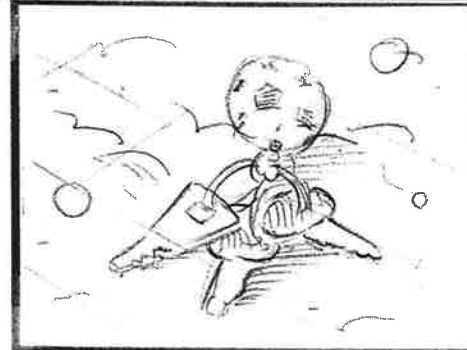

scène	Cam . reu	Time

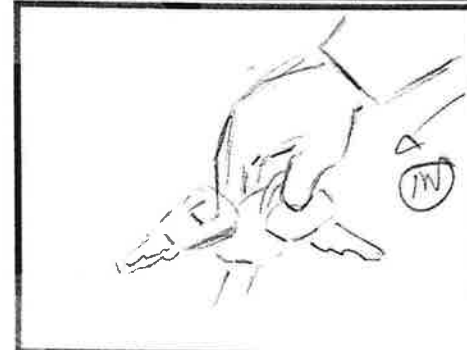

scène	Cam . reu	Time
90		



ACTION

DIALOGUES

TECHNIQUE

66 BG  
Hmmm,

are these Robbie's keys?

ELLIPSANIME

# BIG #CZ

EPISODE : BEST XMAS EVER



	PAGE
	51

scène	Cam . reu	Time



scène	Cam . reu	Time



scène	Cam . reu	Time



scène	Cam . reu	Time



ACTION

DIALOGUES

TECHNIQUE

ROBBIE NEW DIAL REPEAT FROM 26.  
 Mom  
 really wants us at Dad's,

29 ALEX (REPEAT)  
 I can't hurt my Dad's feelings.

**ELLIPSANIME**



# #CZ

## EPISODE : BEST XMAS EVER



	PAGE
	52

scène	Cam . reu	Time
(91)		

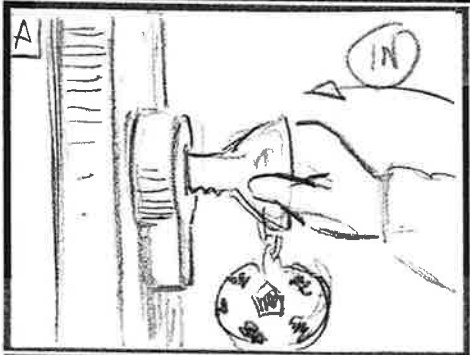

TRK (OUT)  
A → B

scène	Cam . reu	Time

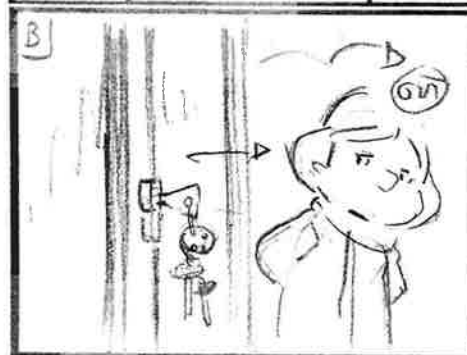

scène	Cam . reu	Time



scène	Cam . reu	Time



ACTION

DIALOGUES

TECHNIQUE

### ELLIPSANIME

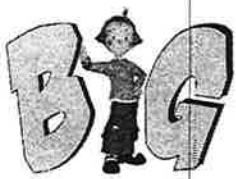

# #CZ

## EPISODE : BEST XMAS EVER



	PAGE
	53

scène	Cam . reu	Time
92		

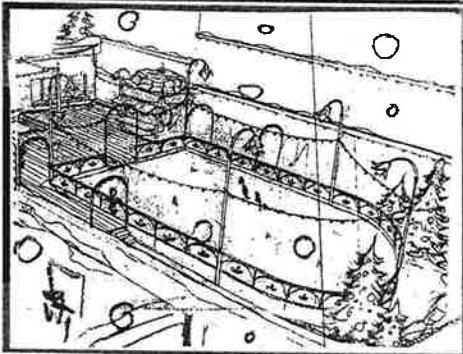

scène	Cam . reu	Time
93		



scène	Cam . reu	Time



scène	Cam . reu	Time
94		

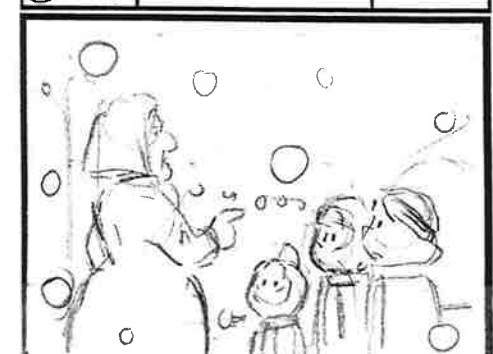

ACTION

DIALOGUES

TECHNIQUE

OUMA ETEINT SON PORTABLE.

67 OUMA  
Sorry, kids,

SFX - BIP

Billy's too busy  
tonight to play goal.

### ELLIPSANIME



# #CZ

## EPISODE : BEST XMAS EVER



	PAGE
	54

scène	Cam . reu	Time



ACTION

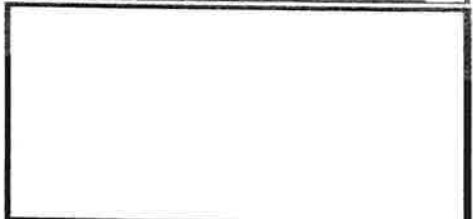

DIALOGUES

68 ALEX  
Guess what?

TECHNIQUE



scène	Cam . reu	Time
95		

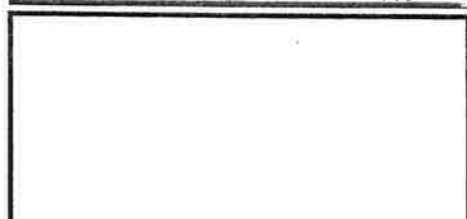

I'm not leaving 'til  
tomorrow after all.

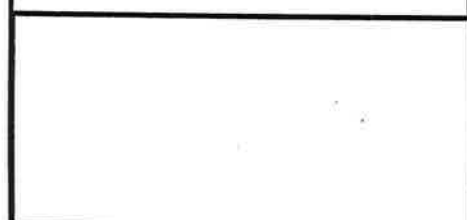

scène	Cam . reu	Time
96		

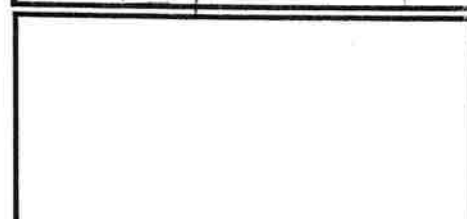

69 GAD  
You're kidding?!

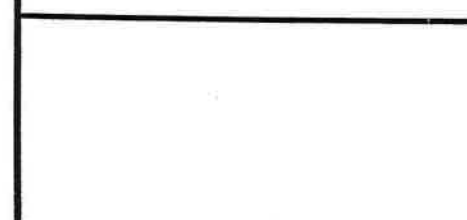

scène	Cam . reu	Time
97		

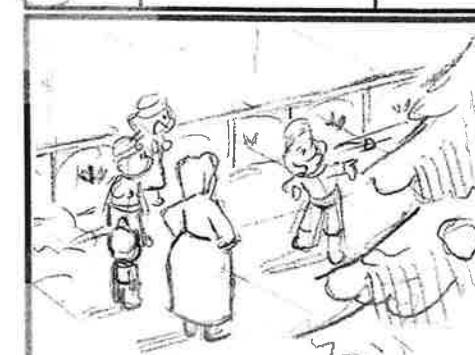

70 ALEX  
(breathless)  
Robbie misplaced his keys.

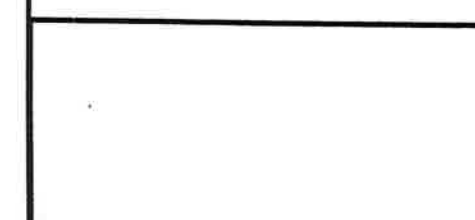

### ELLIPSAiME



# #CZ

## EPISODE : BEST XMAS EVER



	PAGE
	55

scène	Cam . reu	Time

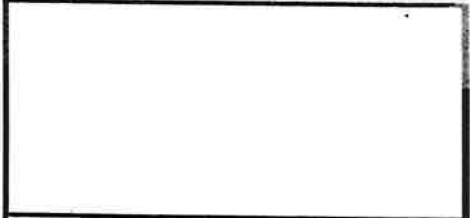
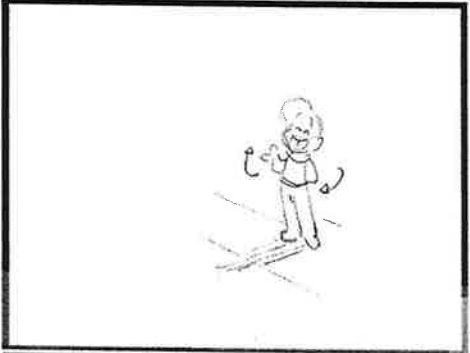

By the time he found them, it was too late.

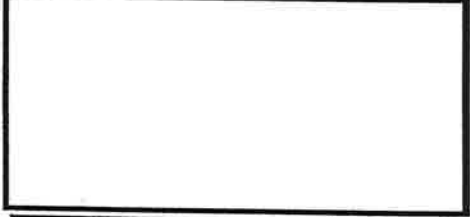

scène	Cam . reu	Time

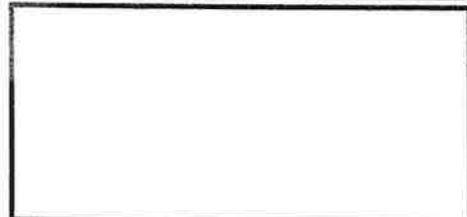
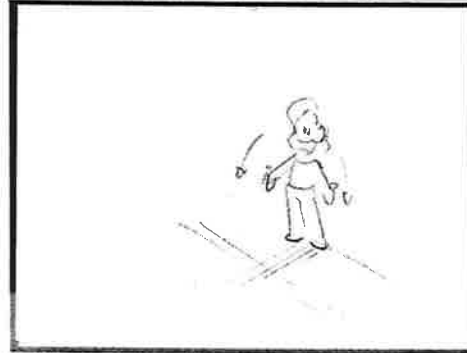

We'd missed our train!

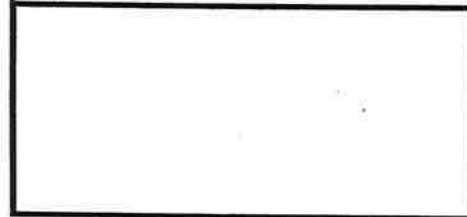

scène	Cam . reu	Time
98		

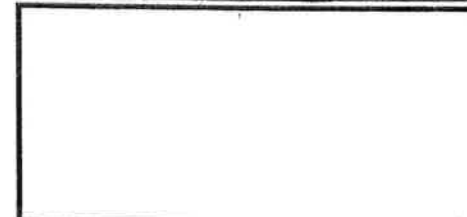
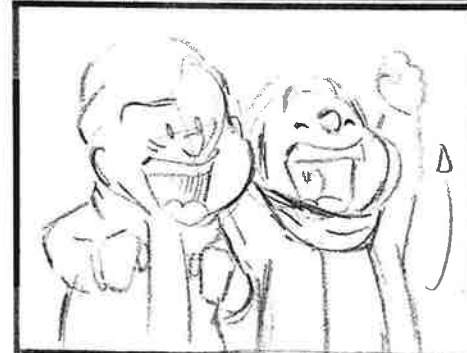

71 BG  
Alright!

72 GAD  
That's excellent, Alex!

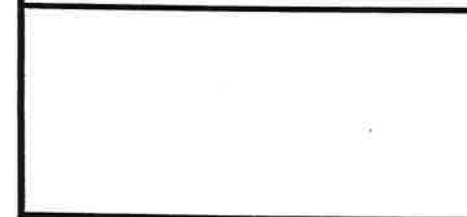

scène	Cam . reu	Time



73 BG  
(slightly nervous)  
..yeah, and

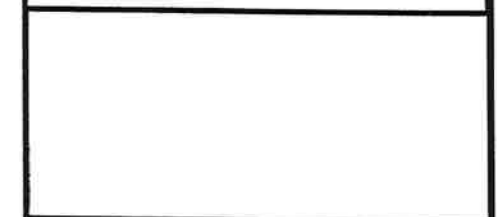

ACTION

DIALOGUES

TECHNIQUE

### ELLIPSANiME



# #CZ

## EPISODE : BEST XMAS EVER



	PAGE
	56

scène	Cam . reu	Time



ACTION

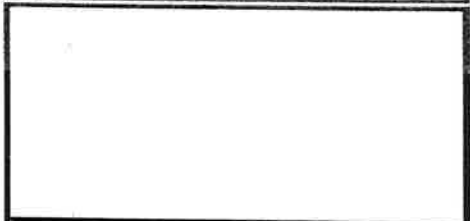

DIALOGUES

about the keys, er,

TECHNIQUE



scène	Cam . reu	Time

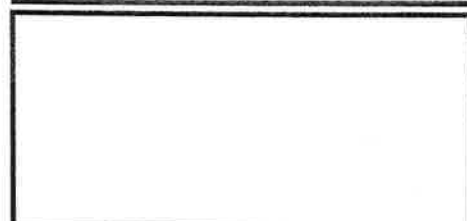

good thing Robbie found them.



scène	Cam . reu	Time
99		

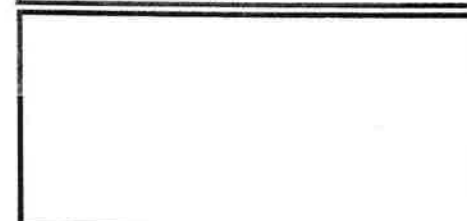
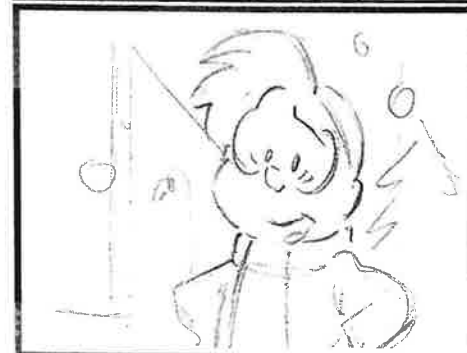

74 ALEX  
...I guess so. (Beat)

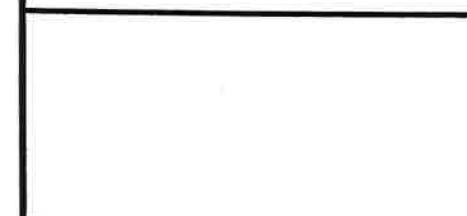

scène	Cam . reu	Time



He's pretty upset though.

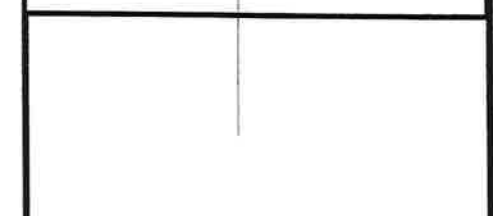

### ELLIPSANIME



# BIG #CZ

EPISODE : BEST XMAS EVER



	PAGE
	57

ACTION

DIALOGUES

TECHNIQUE

scène	Cam . reu	Time

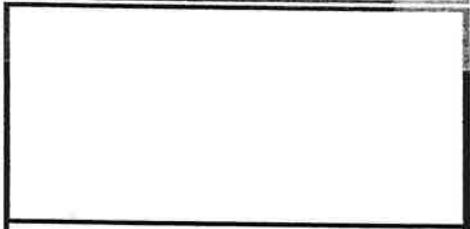

And my Mom and Dad  
won't like it either.

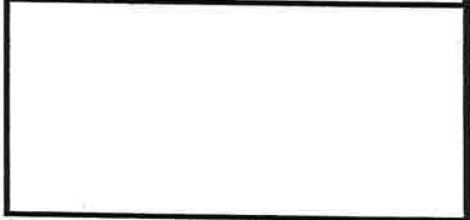

scène	Cam . reu	Time
100		

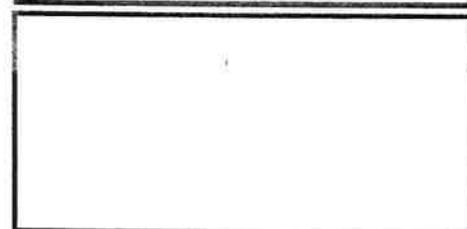

75 BG  
Well

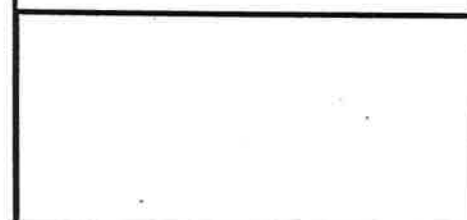

scène	Cam . reu	Time

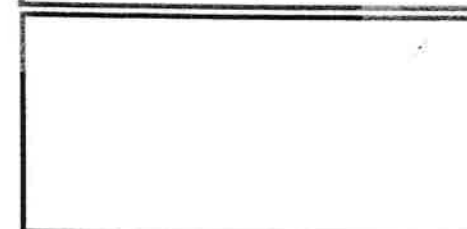

it's not your fault!

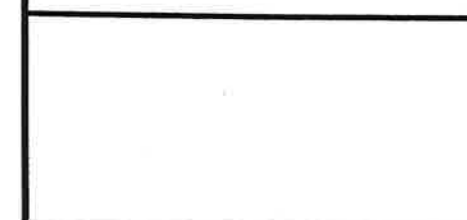

scène	Cam . reu	Time



76 ALEX  
We'd just better win tonight after  
all this trouble.



**ELLIPSANIME**



# #CZ

## EPISODE : BEST XMAS EVER



	PAGE
	58

scène	Cam . reu	Time

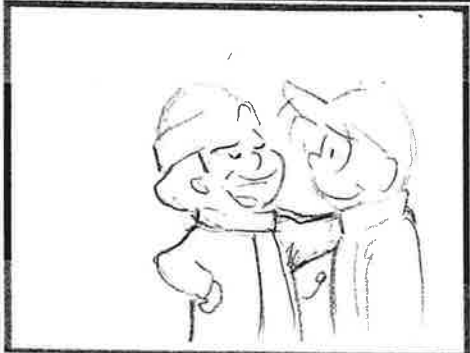

BG MET LA MAIN SUR L'ÉPAULE D'ALEX.

ACTION

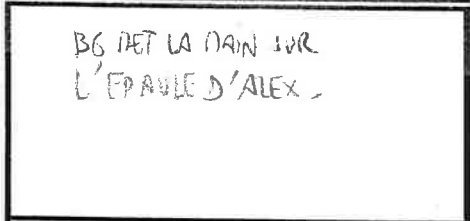

DIALOGUES

77 BG  
With you back in goal,  
  
no problem!

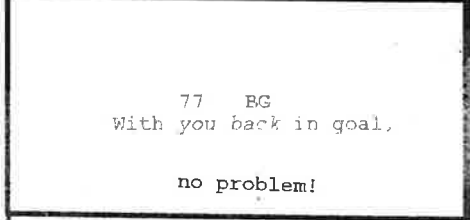

TECHNIQUE



scène	Cam . reu	Time
(1st)		

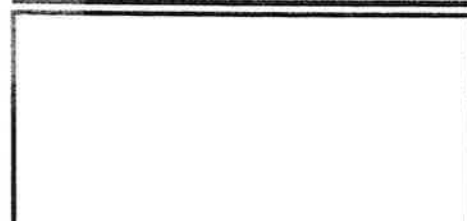
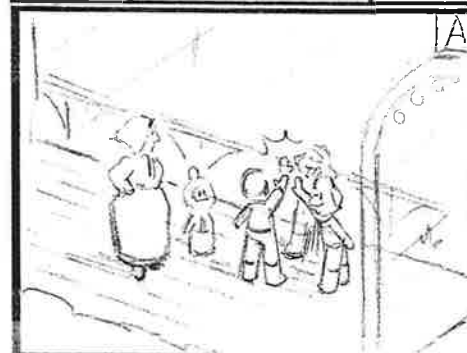

The Tree House Squad is unbeatable.

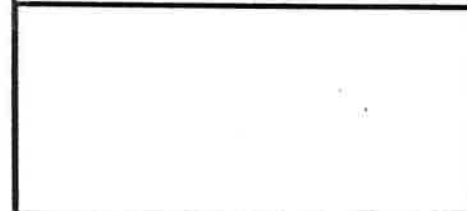
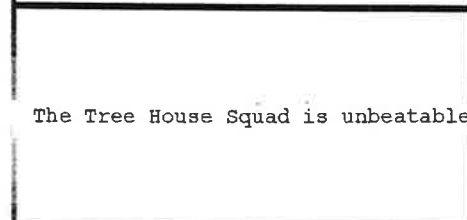

scène	Cam . reu	Time



OUTIA APPLAUDIT  
GEORGE SAUTILE SUR PLACE.

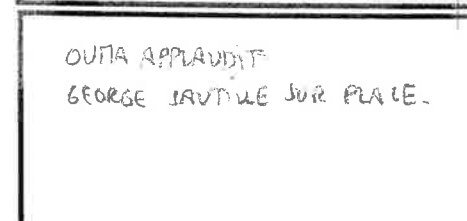

78 GEORGE  
Yippee!

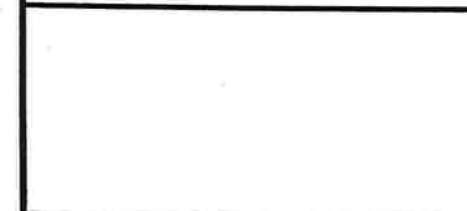
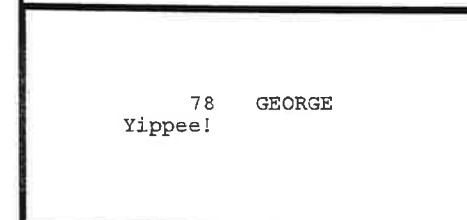

scène	Cam . reu	Time



SHIFT →

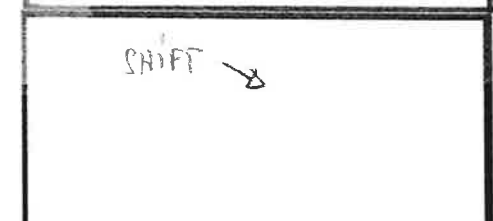

79 ROBBIE  
Alex!

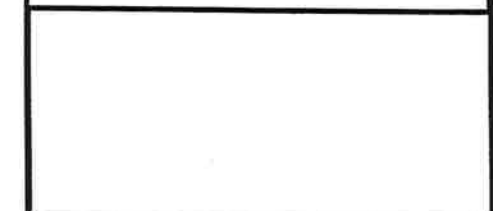
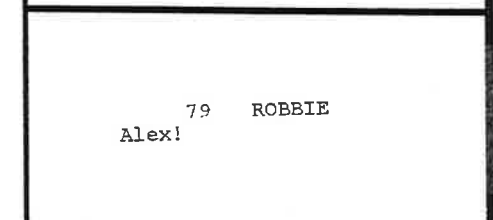

### ELLIPSANIME

# BIG #CZ

EPISODE : BEST XMAS EVER



	PAGE
	59

scène	Cam . reu	Time
102		



ACTION

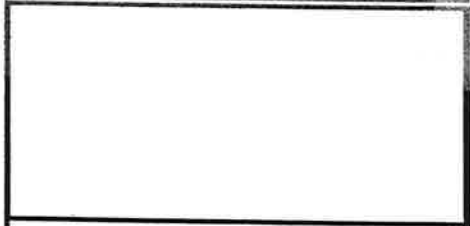

DIALOGUES

It's all taken care of.

TECHNIQUE

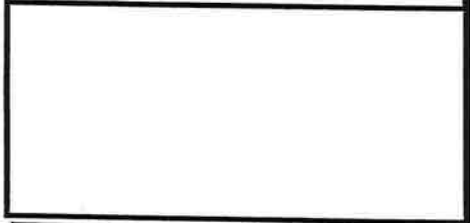

scène	Cam . reu	Time

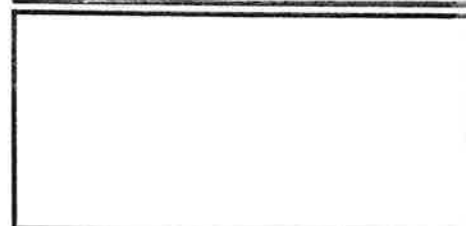

I just phoned Dad and he's coming to pick us up.

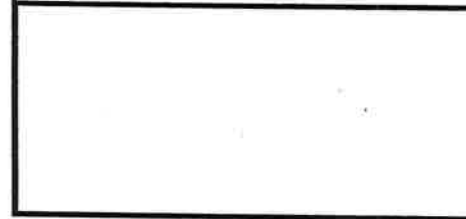

scène	Cam . reu	Time
103		

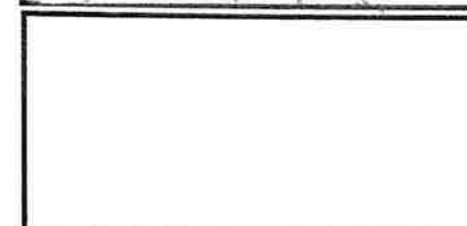
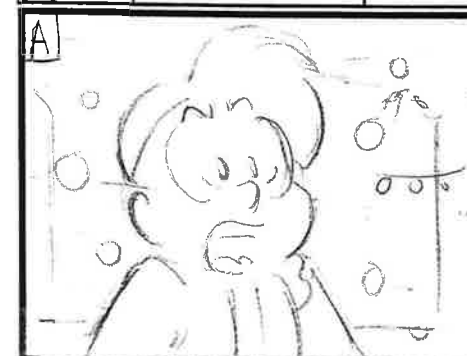

He'll be here in a hour and a half.

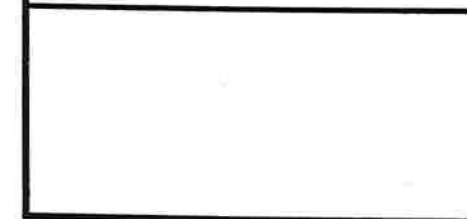

scène	Cam . reu	Time



TRK OUT

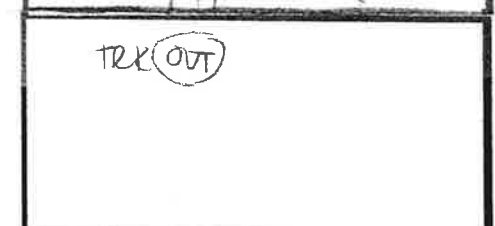

80 BG  
(beat, beaming)  
That's perfect! '

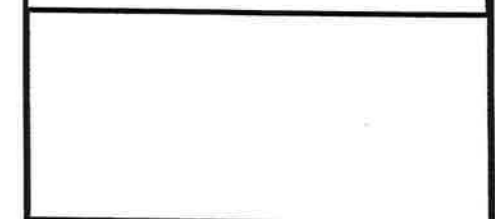

**ELLIPSANiME**



# #CZ

## EPISODE : BEST XMAS EVER



	PAGE
	60

scène	Cam . reu	Time



ACTION

DIALOGUES

(to Alex) He can stay and watch the game now.

TECHNIQUE

scène	Cam . reu	Time



ACTION

DIALOGUES

ROBBIE  
ER...

TECHNIQUE

scène	Cam . reu	Time
104		



ACTION

DIALOGUES

81 ROBBIE  
I'm sure Dad would like that,

TECHNIQUE

scène	Cam . reu	Time



ACTION

DIALOGUES

but  
the roads are pretty bad,

TECHNIQUE

### ELLIPSANIME



# #CZ

## EPISODE : BEST XMAS EVER

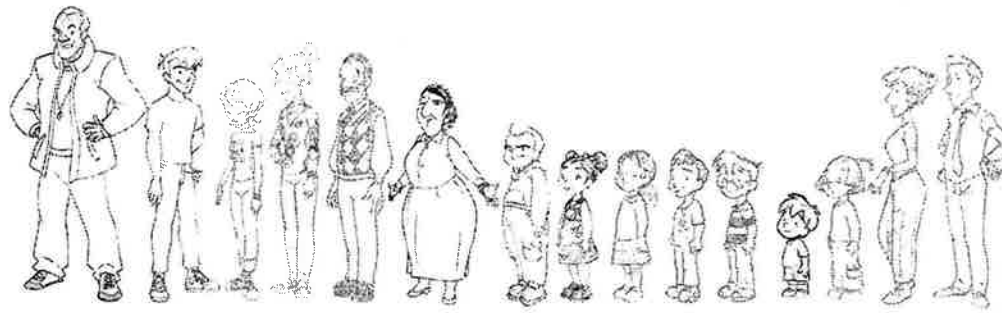

	PAGE
	61

scène	Cam . reu	Time



scène	Cam . reu	Time
105		



scène	Cam . reu	Time
106		



scène	Cam . reu	Time



ACTION

DIALOGUES

TECHNIQUE

he wants  
to get home before dark.

82 ROBBIE  
Sorry, bud.

now. I'm gonna call Mom,

### ELLIPSANiME



# #CZ

## EPISODE : BEST XMAS EVER



	PAGE
	62

scène	Cam . reu	Time

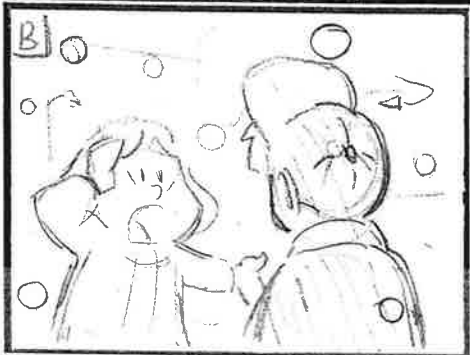

ACTION

83 BG  
I can't believe this!

TECHNIQUE

scène	Cam . reu	Time



ACTION

plans?! After all our

TECHNIQUE

scène	Cam . reu	Time
107		



ACTION

84 ALEX  
Neither can I.

TECHNIQUE

scène	Cam . reu	Time
108		

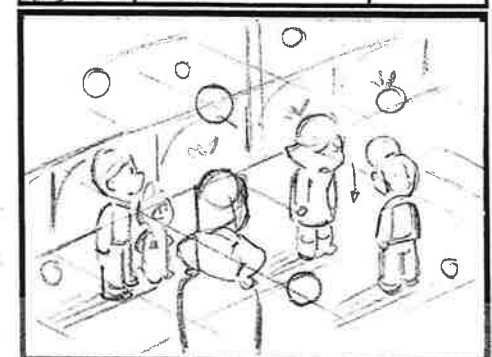

ACTION

85 BG  
We'll never win now.

TECHNIQUE

### ELLIPSANIME

# BIG #CZ

EPISODE : BEST XMAS EVER



	PAGE
	63

ACTION

DIALOGUES

TECHNIQUE

scène	Cam . reu	Time

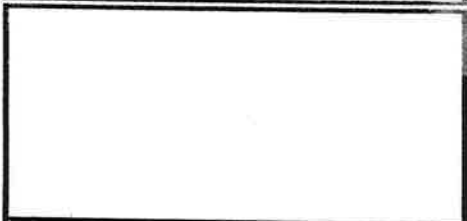
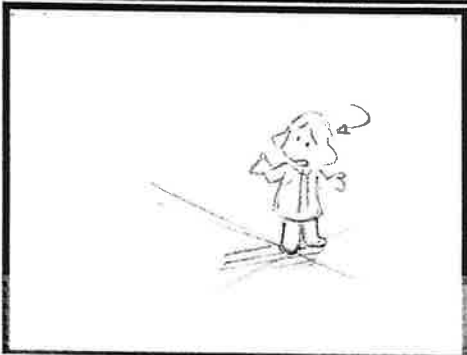

What's the point of even showing up?



scène	Cam . reu	Time

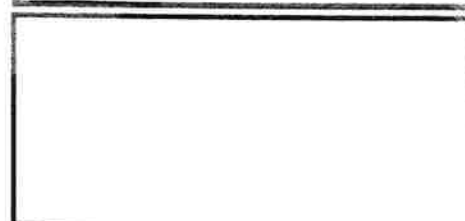

86 GAD  
We can take turns being goalie,

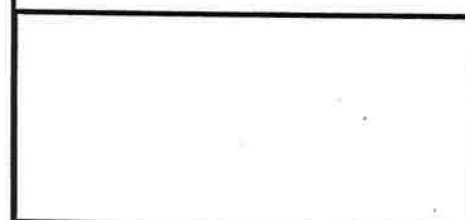

scène	Cam . reu	Time
109		

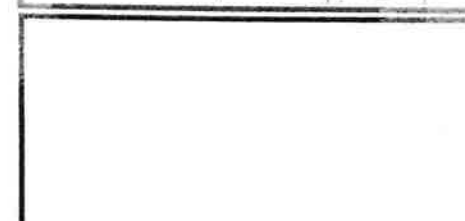
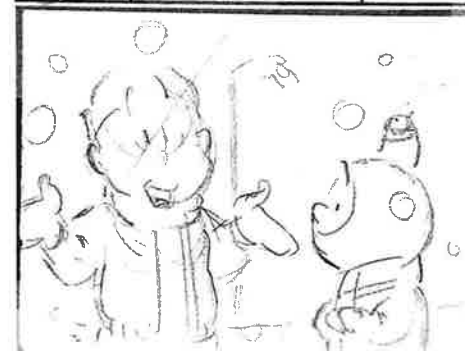

you know, improvise.

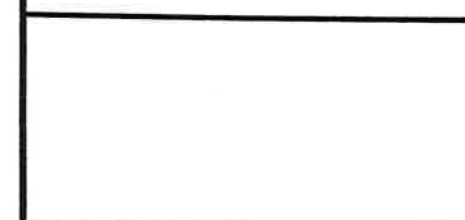

scène	Cam . reu	Time



87 GEORGE  
I could be goalie.

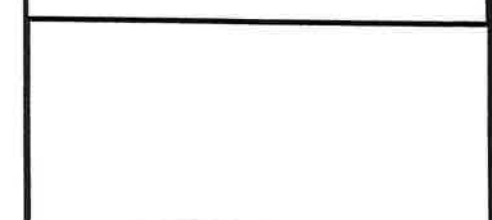

**ELLIPSANiME**

# BIG #CZ

EPISODE : BEST XMAS EVER



	PAGE
	64

scène	Cam . reu	Time
(110)		



scène	Cam . reu	Time



scène	Cam . reu	Time
(111)		



scène	Cam . reu	Time



ACTION

DIALOGUES

TECHNIQUE

88 BG  
For the Championship, George?

don't think so! I

89 GAD  
Don't get mad at George,

his fault. it's not

**ELLIPSANIME**





# #CZ

## EPISODE : BEST XMAS EVER



	PAGE
	65

scène	Cam . reu	Time



ACTION

DIALOGUES

90 BG  
Right, I know,

TECHNIQUE

scène	Cam . reu	Time



ACTION

DIALOGUES

it's no one's fault,

TECHNIQUE

scène	Cam . reu	Time



ACTION

DIALOGUES

it's just the worst Christmas ever,  
that's all.

TECHNIQUE

scène	Cam . reu	Time



ACTION

DIALOGUES

Bg-- 91 ALEX

TECHNIQUE

### ELLIPSANIME



# #CZ

## EPISODE : BEST XMAS EVER



	PAGE
	66

scène	Cam . reu	Time
(112)		



ACTION

DIALOGUES

TECHNIQUE

92 BG  
 (cuts him off abruptly)  
 Have fun at your dad's, Alex.

scène	Cam . reu	Time



'Bye.

scène	Cam . reu	Time
(113)		



ALEX REPEAT (91)  
 BG!

scène	Cam . reu	Time



SHIFT  
 B ← A

93 OUMA  
 Bg will be fine, don't worry.

### ELLIPSANIME



# #CZ

## EPISODE : BEST XMAS EVER



	PAGE
	67

scène	Cam . reu	Time



ACTION

DIALOGUES

94 GAD  
Yeah, she'll get over it.

TECHNIQUE

scène	Cam . reu	Time
114		

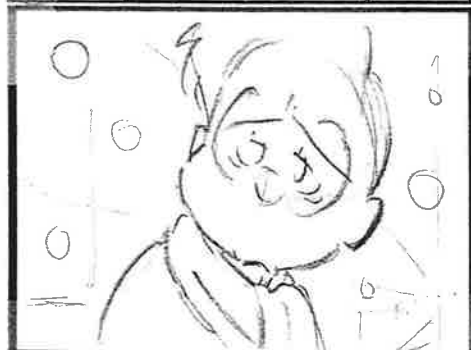

ACTION

DIALOGUES

TECHNIQUE

scène	Cam . reu	Time

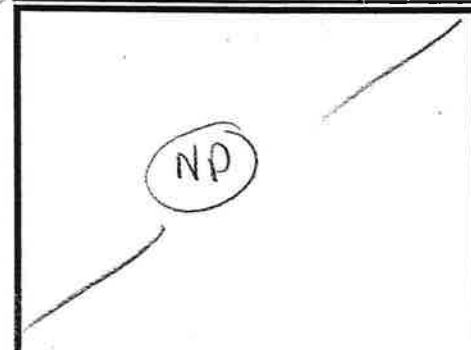

ACTION

DIALOGUES

TECHNIQUE

scène	Cam . reu	Time

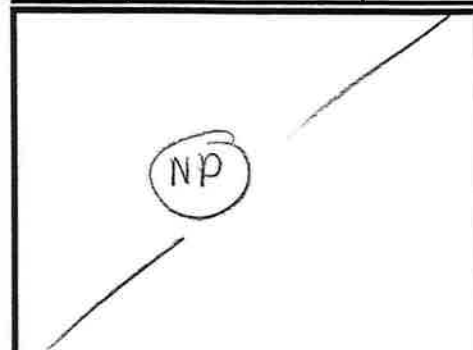

ACTION

DIALOGUES

TECHNIQUE

### ELLIPSANIME

# BIG

# #CZ

## EPISODE : BEST XMAS EVER



	PAGE
	68

scène	Cam . reu	Time
(115)		

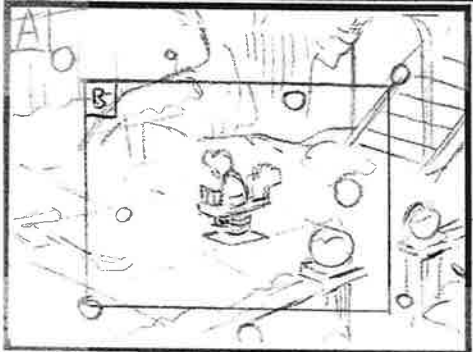

SLOW TRK (M)

ACTION

DIALOGUES

TECHNIQUE

scène	Cam . reu	Time
(116)		



scène	Cam . reu	Time
(117)		



scène	Cam . reu	Time
(118)		



95 GEORGE  
Sorry, Alex.

### ELLIPSANIME



# #CZ

## EPISODE : BEST XMAS EVER



	PAGE
	69

scène	Cam . reu	Time



ACTION

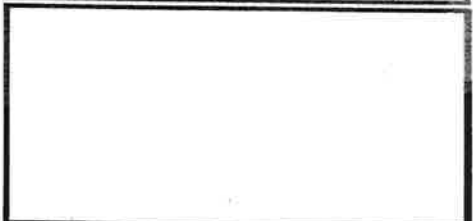

DIALOGUES

96 ALEX  
So am I,

TECHNIQUE



scène	Cam . reu	Time

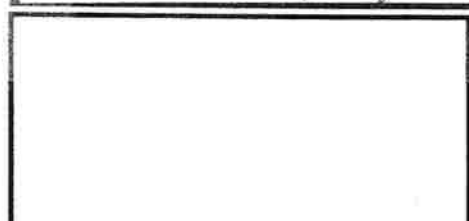

everyone's upset with me.

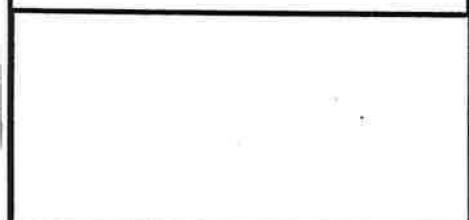

scène	Cam . reu	Time

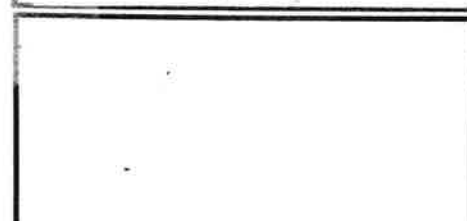

No matter what I do,

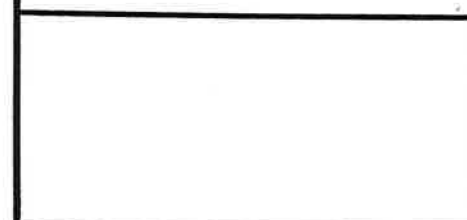

scène	Cam . reu	Time



someone. I disappoint

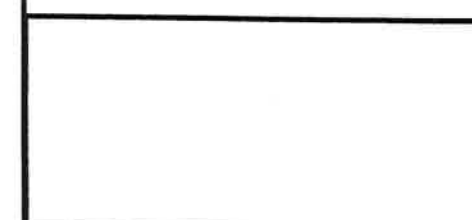

### ELLIPSANIME

# BIG

# #CZ

## EPISODE : BEST XMAS EVER



	PAGE
	70

scène	Cam . reu	Time
(117)		



scène	Cam . reu	Time
(118)		



scène	Cam . reu	Time
(119)		



scène	Cam . reu	Time



ACTION

DIALOGUES

TECHNIQUE



97 ALEX  
I wish I could go somewhere and disappear for a while.

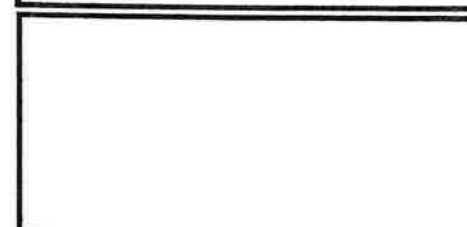
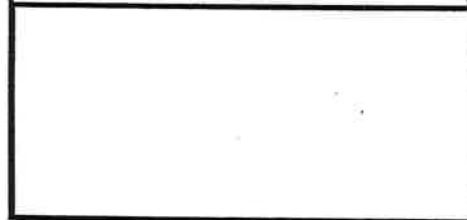

98 GEORGE  
...I know a good place.

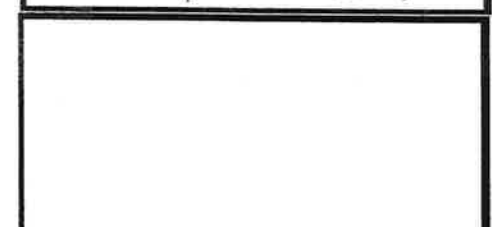
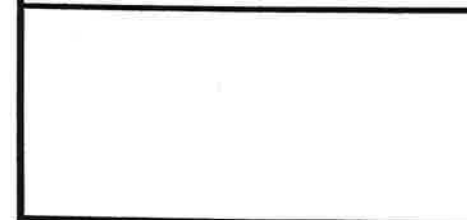

98 GEORGE  
...I know a good place.

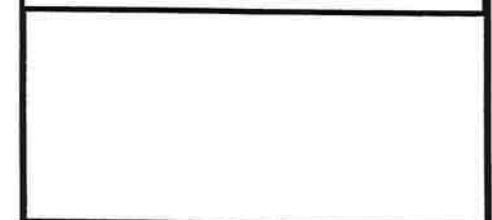

### ELLIPSANIME



#CZ

EPISODE : BEST XMAS EVER



	PAGE
	71

scène	Cam . reu	Time
(120)		

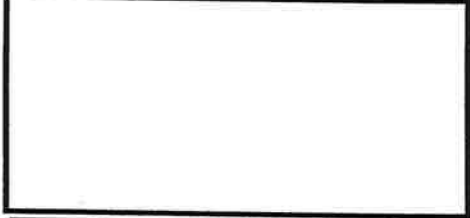
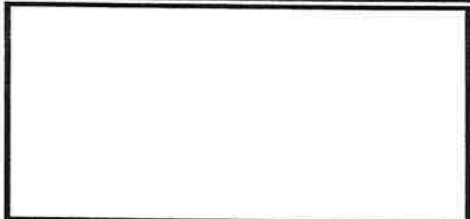
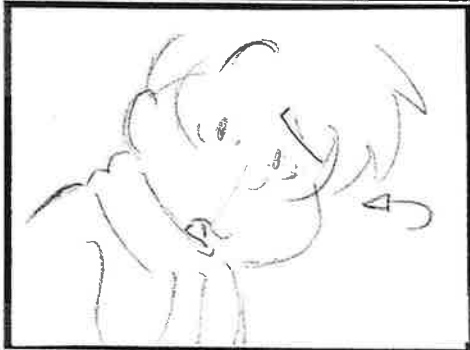

scène	Cam . reu	Time

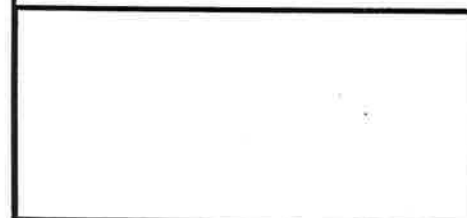
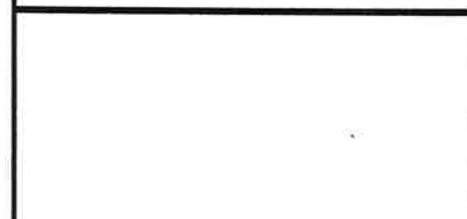
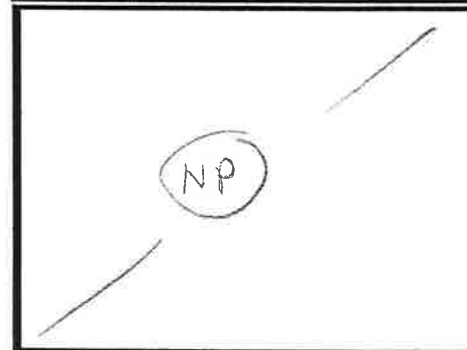

scène	Cam . reu	Time

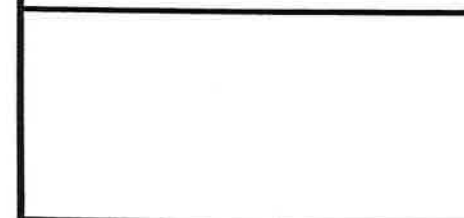
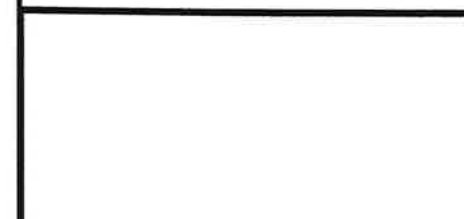
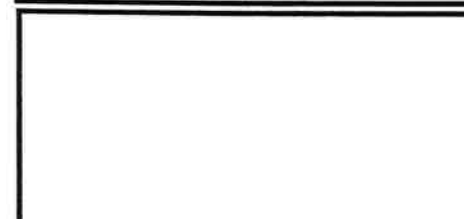
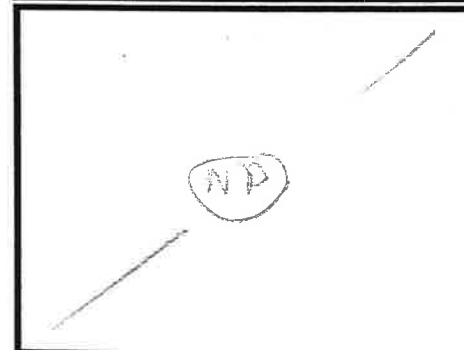

scène	Cam . reu	Time

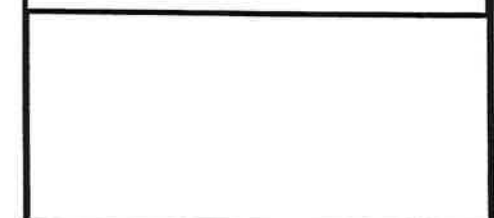
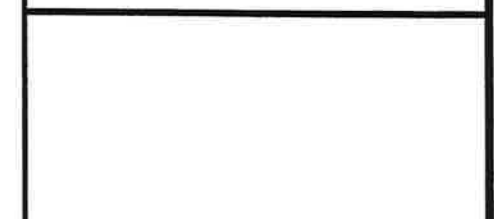
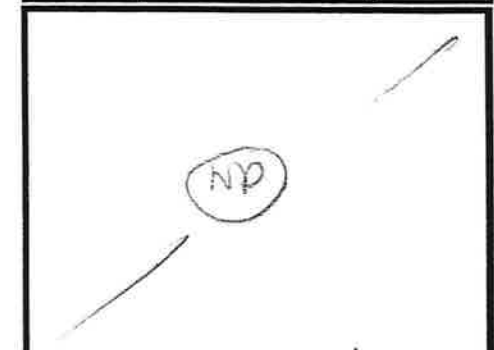

ACTION

DIALOGUES

TECHNIQUE

**ELLIPSANIME**

# BIG #CZ

EPISODE : BEST XMAS EVER



	PAGE
	72

scène	Cam . reu	Time
(121)		



ACTION

DIALOGUES

99 MOM  
Bg! Could you come downstairs please?

TECHNIQUE

scène	Cam . reu	Time
(122)		

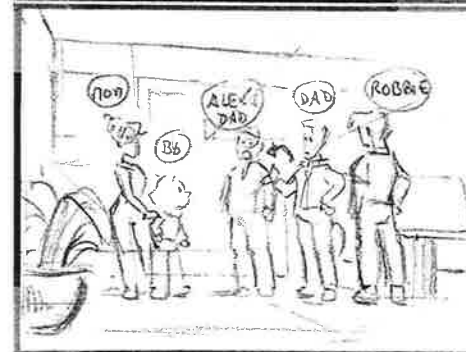

ACTION

DIALOGUES

102 DAD  
Bg, you know Alex's father, right?

TECHNIQUE

scène	Cam . reu	Time
(123)		



ACTION

DIALOGUES

103 BG  
...Uh-huh.

TECHNIQUE

scène	Cam . reu	Time
(124)		



ACTION

DIALOGUES

104 ALEX'S DAD  
(urgently)  
Have you seen Alex recently?

TECHNIQUE

**ELLIPSANIME**





# #CZ

## EPISODE : BEST XMAS EVER



	PAGE
	73

scène	Cam . reu	Time
125		

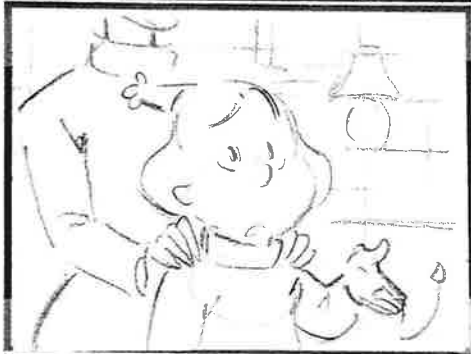

ACTION

DIALOGUES

TECHNIQUE

105 BG  
No, not since the skating rink.

scène	Cam . reu	Time
126		

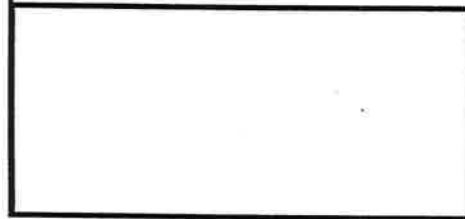
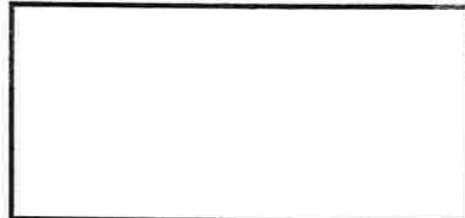

scène	Cam . reu	Time
127		

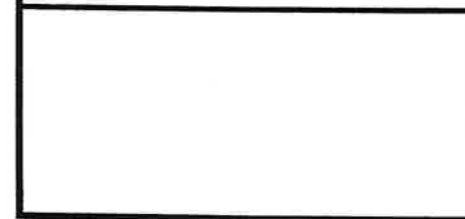
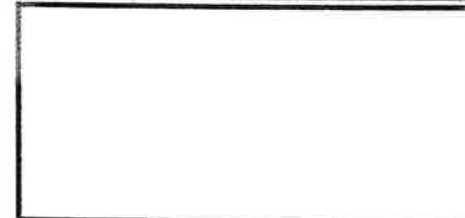

scène	Cam . reu	Time

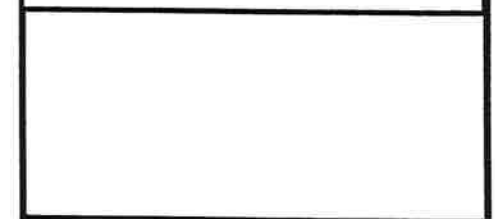
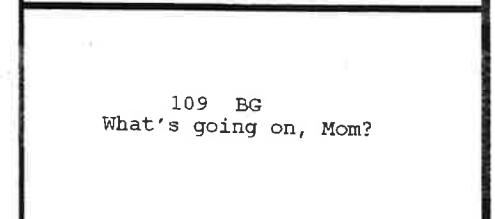
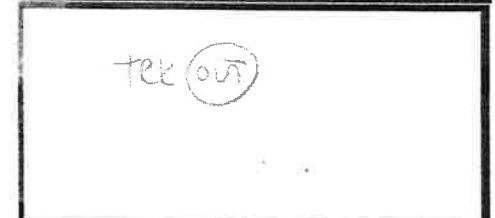

tek out

109 BG  
What's going on, Mom?

### ELLIPSANIME

# BIG #CZ

EPISODE : BEST XMAS EVER



	PAGE
	74

scène	Cam . reu	Time

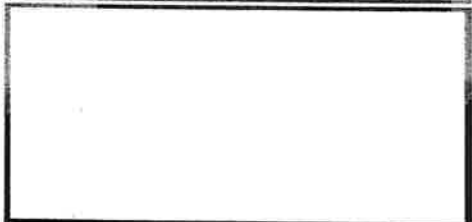
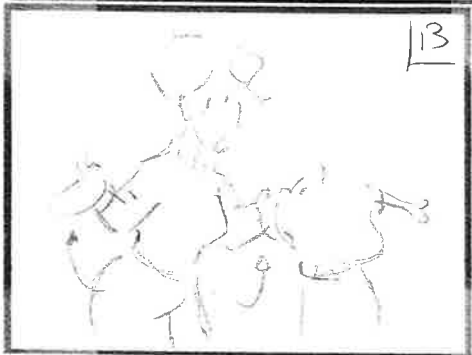

110 MOM  
We can't find Alex, sweetie.

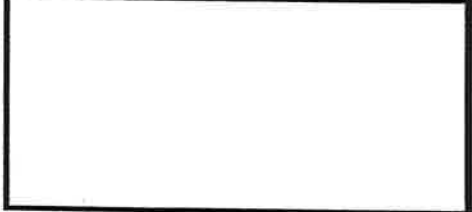

scène	Cam . reu	Time



looks like he's run off. It

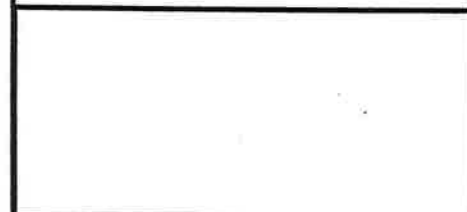

scène	Cam . reu	Time
118		

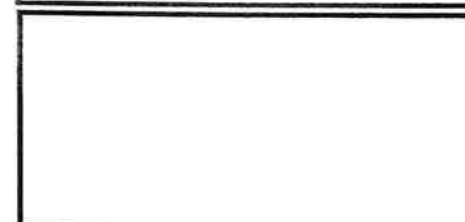

111 BG  
(leaps out of her)  
...Really?

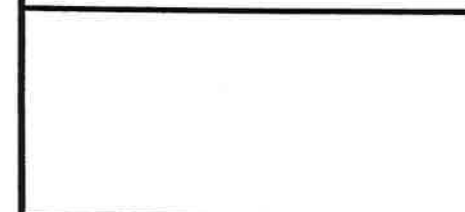

scène	Cam . reu	Time



112 BG (VO)  
I knew Alex wouldn't let the team down!

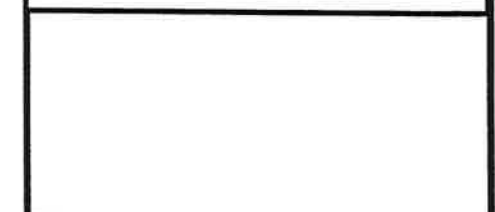

ACTION

DIALOGUES

TECHNIQUE

**ELLIPSANIME**



# #CZ

## EPISODE : BEST XMAS EVER



	PAGE
	75

scène	Cam . reu	Time



ACTION

DIALOGUES

TECHNIQUE

113 MOM  
Why are you smiling,

scène	Cam . reu	Time
129		



it's not funny.

scène	Cam . reu	Time



SHIFT →

His father's very worried.

scène	Cam . reu	Time



114 MOM  
Alex was looking forward to  
spending Christmas with him.

### ELLIPSANIME



# #CZ

## EPISODE : BEST XMAS EVER



	PAGE
	76

scène	Cam . reu	Time
(30)		



ACTION

DIALOGUES

TECHNIQUE

What on earth could have made him run away?

scène	Cam . reu	Time
(31)		



115 BG (VO)  
...I suddenly didn't feel so good.

scène	Cam . reu	Time



Alex really WAS upset about missing the game.

scène	Cam . reu	Time



TRK (OUT) A-B

116 MOM  
Bg, are you hiding something?

### ELLIPSANiME



# #CZ

## EPISODE : BEST XMAS EVER



	PAGE
	77

scène	Cam . reu	Time



ACTION

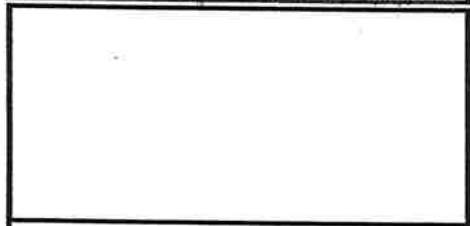

DIALOGUES

This is serious,

TECHNIQUE



scène	Cam . reu	Time



if you know where Alex is, you have to tell me, right now.

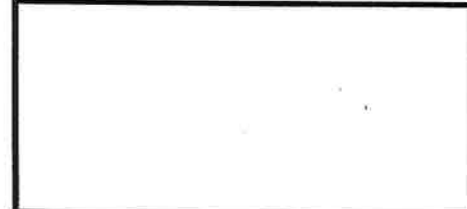

scène	Cam . reu	Time

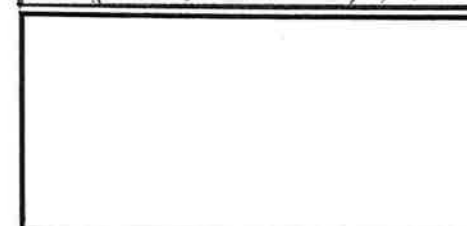

117 BG  
I don't know, Mom, honest!

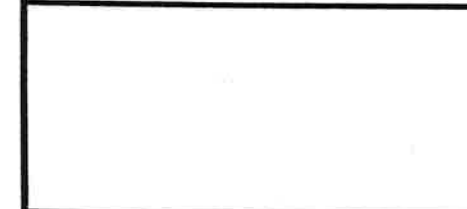

scène	Cam . reu	Time
(182)		



.... I might know

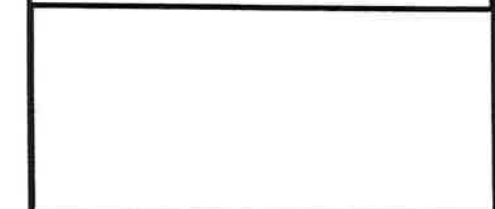

### ELLIPSANIME

# BIG

# #CZ

## EPISODE : BEST XMAS EVER



	PAGE
	78

scène	Cam . reu	Time



ACTION

DIALOGUES

WHY he ran away.

TECHNIQUE

scène	Cam . reu	Time
133		



ACTION

DIALOGUES

TECHNIQUE

scène	Cam . reu	Time



ACTION

DIALOGUES

118 MOM  
Well tell me.

TECHNIQUE

scène	Cam . reu	Time
134		



ACTION

DIALOGUES

119 BG  
(hesitant)  
Alex was going to leave early, and he'd miss our game, Mom!

TECHNIQUE

### ELLIPSANIME



# #CZ

## EPISODE : BEST XMAS EVER



	PAGE
	79

scène	Cam . reu	Time
135		

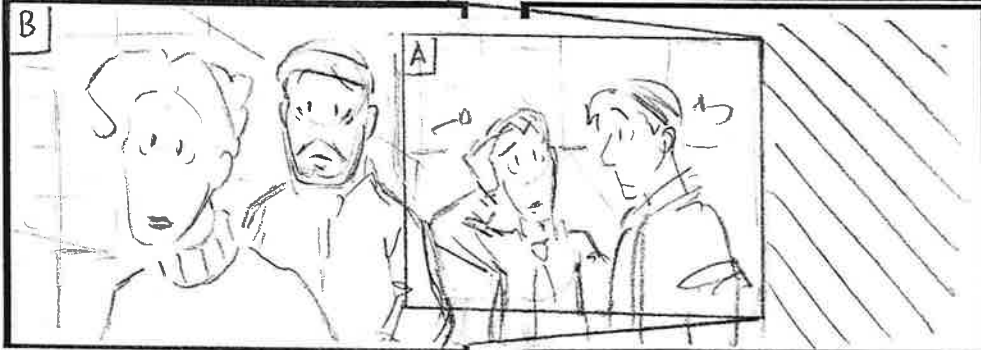

ACTION

DIALOGUES

So we tried all this stuff to make him miss the train, but it didn't work

TECHNIQUE

scène	Cam . reu	Time



ACTION

DIALOGUES

TECHNIQUE

scène	Cam . reu	Time
136		



ACTION

DIALOGUES

and then I got mad at him.

TECHNIQUE

scène	Cam . reu	Time



ACTION

DIALOGUES

This is all my fault,

TECHNIQUE

### ELLIPSANIME



# #CZ

## EPISODE : BEST XMAS EVER



	PAGE
	80

scène	Cam . reu	Time
137		



ACTION

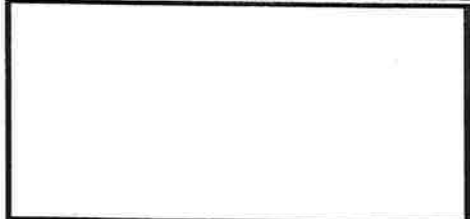

DIALOGUES

I hope he's okay.

TECHNIQUE



scène	Cam . reu	Time



120 MOM  
Oh Bg, that was very wrong,



scène	Cam . reu	Time

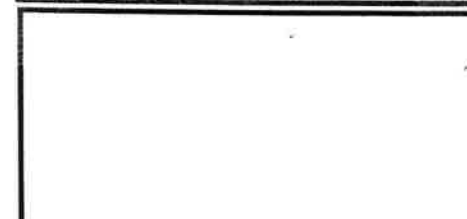

we'll talk about that later,

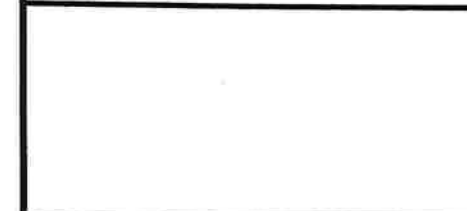

scène	Cam . reu	Time

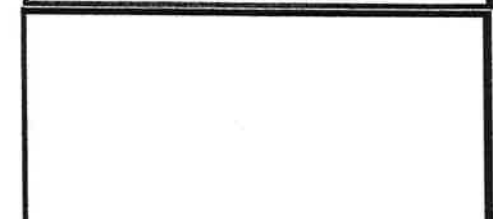

but right  
now we have to find Alex.

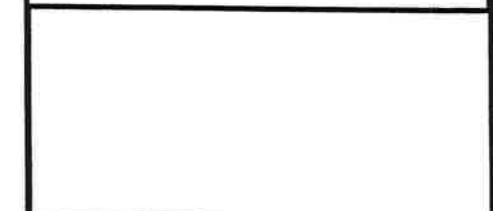

### ELLIPSANIME





# #CZ

## EPISODE : BEST XMAS EVER



	PAGE
	81

scène	Cam . reu	Time
138		



scène	Cam . reu	Time
139		



scène	Cam . reu	Time



scène	Cam . reu	Time
140		



ACTION

DIALOGUES

TECHNIQUE

121 ALEX'S DAD  
(to Bg)  
You're sure you have no idea were  
he is?

122 BG  
...No, I'm really sorry.

don't be mad at him. Please

106 DAD  
(to Robbie)  
Maybe you should go search the rink  
again, Robbie, and the area around  
it.

### ELLIPSANiME

# BIG #CZ

EPISODE : BEST XMAS EVER



	PAGE
	82

scène	Cam . reu	Time



← SHIFT

107 ALEX'S DAD  
(to Bg's Dad)  
What about going door to door?

TECHNIQUE

scène	Cam . reu	Time



108 DAD  
Good idea, I'll help you.

123 GEORGE  
I know where Alex is.

TECHNIQUE

scène	Cam . reu	Time



123 GEORGE  
I know where Alex is.

TECHNIQUE

scène	Cam . reu	Time
(14)		



GEORGE  
GIGGLES

TECHNIQUE

**ELLIPSANIME**



# #CZ

## EPISODE : BEST XMAS EVER



	PAGE
	83

scène	Cam . reu	Time
142		

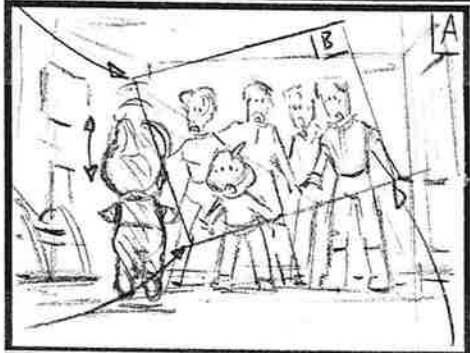

TILT TRK (IN) A → B .

ACTION

DIALOGUES

124 MOM  
(eager, to George)  
..You do??

TECHNIQUE

scène	Cam . reu	Time
/		

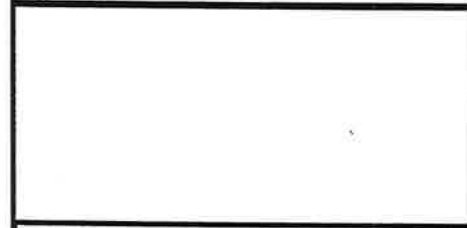
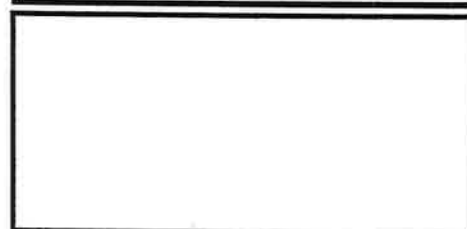
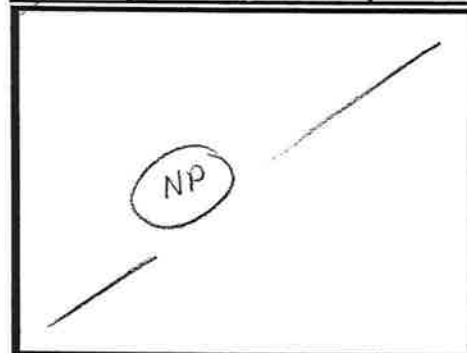

scène	Cam . reu	Time
/		

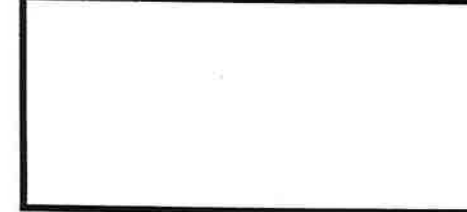
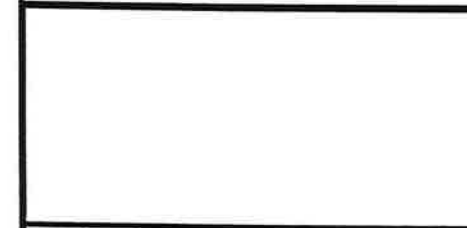
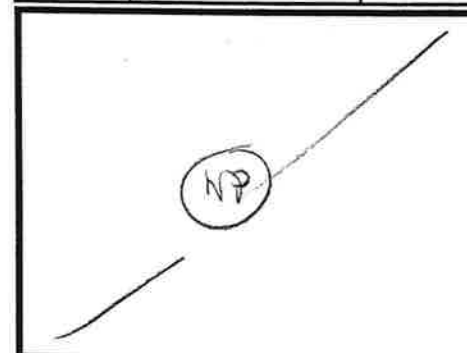

scène	Cam . reu	Time
/		

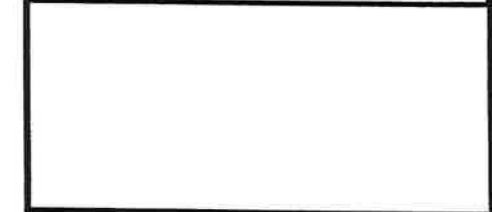
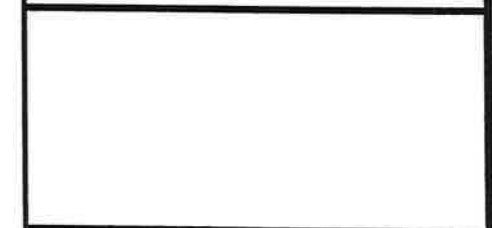
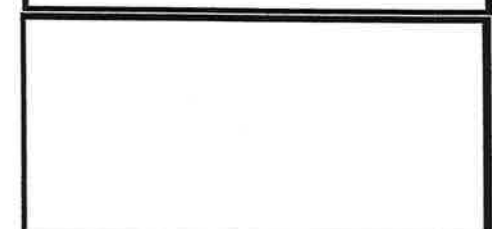
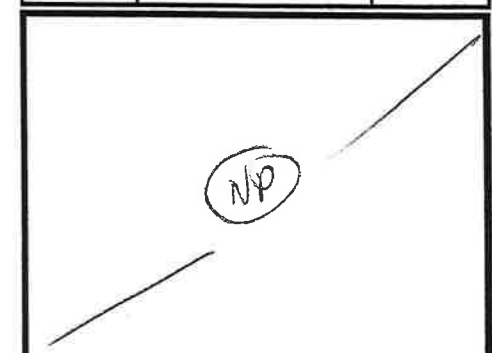

### ELLIPSANIME



# #CZ

## EPISODE : BEST XMAS EVER



	PAGE
	84

scène	Cam . reu	Time
143		

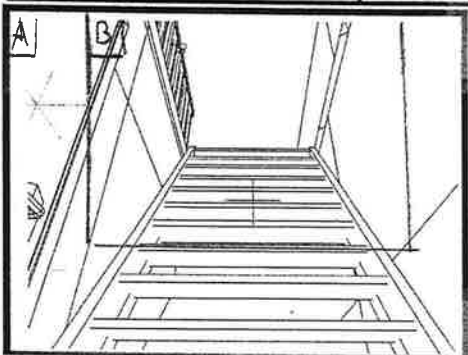

TRC (W) A → B.

ACTION

DIALOGUES

TECHNIQUE

scène	Cam . reu	Time
144		

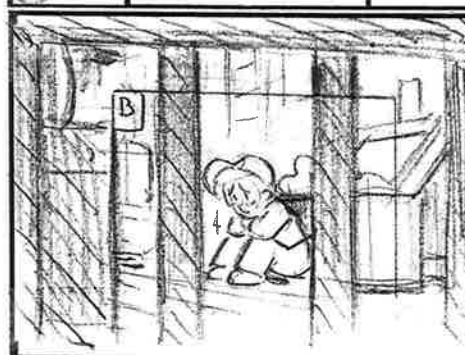

scène	Cam . reu	Time



125 ALEX'S DAD  
Hey Buddy.

scène	Cam . reu	Time
145		



126 ALEX  
Dad! (nervous)

### ELLIPSANIME

# BIG

# #CZ

## EPISODE : BEST XMAS EVER

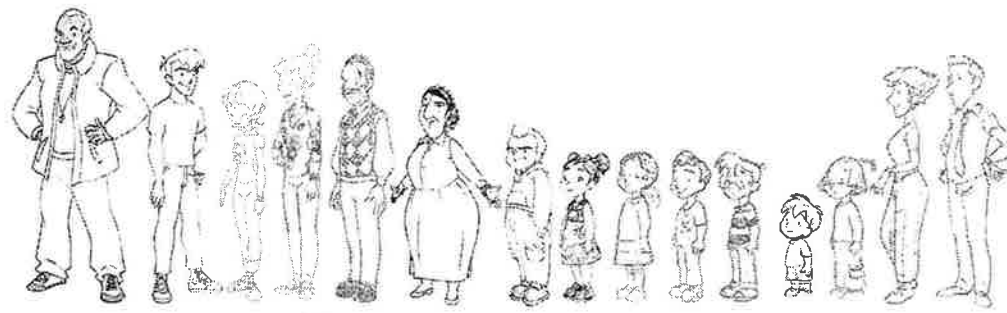

	PAGE
	85

scène	Cam . reu	Time
146		

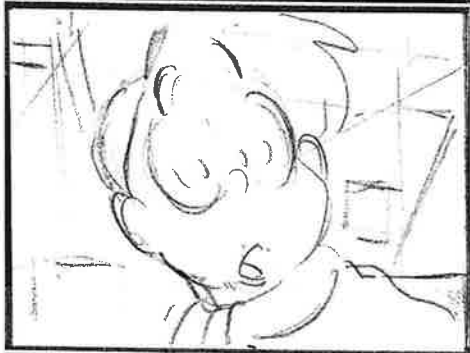

scène	Cam . reu	Time
147		



scène	Cam . reu	Time
148		

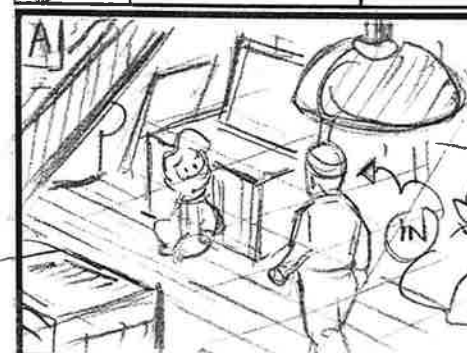

scène	Cam . reu	Time



ACTION

(CAM)  
 ! de A à B p.88, LA CAMÉRA

← CAM  
 NE CESSÉ DE TOURNER -

DIALOGUES

How'd you find me?

127 ALEX'S DAD  
 I have my ways.

128 ALEX'S DAD  
 So... how's it going?

129 ALEX  
 Not so good.

TECHNIQUE

### ELLIPSANIME



# #CZ

## EPISODE : BEST XMAS EVER



	PAGE
	86

scène	Cam . reu	Time

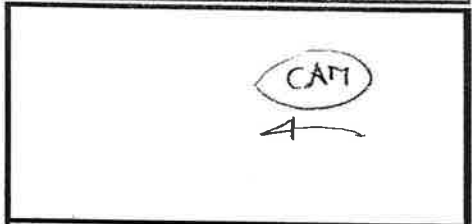

130 ALEX'S DAD  
 Hmmm. well, we'd better find a way to fix that.



scène	Cam . reu	Time

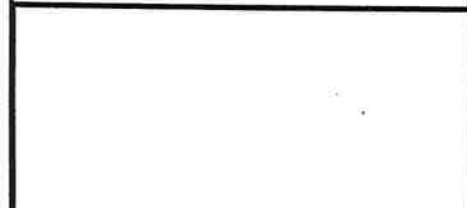
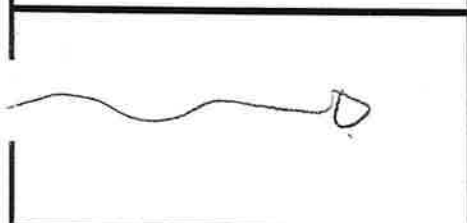
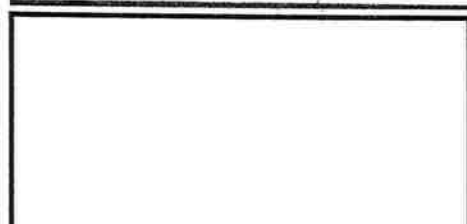

scène	Cam . reu	Time

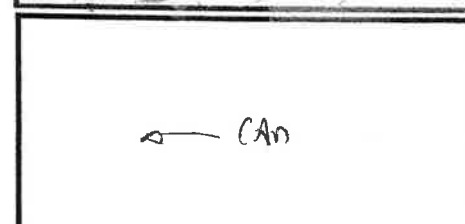
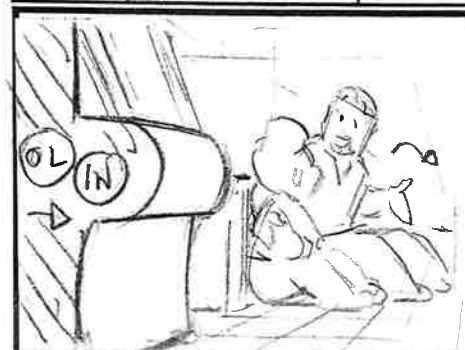

131 ALEX'S DAD  
 I hear there's a hockey game on tonight.

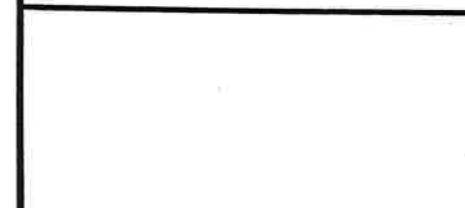

scène	Cam . reu	Time

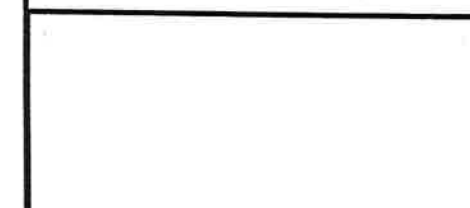
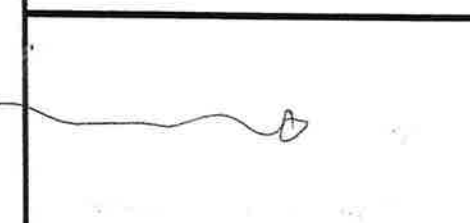

ACTION

DIALOGUES

TECHNIQUE

### ELLIPSANIME

# BIG

# #CZ

## EPISODE : BEST XMAS EVER



	PAGE
	87

scène	Cam . reu	Time



CAN  
←

Maybe I should stick around and watch it.

TECHNIQUE

scène	Cam . reu	Time

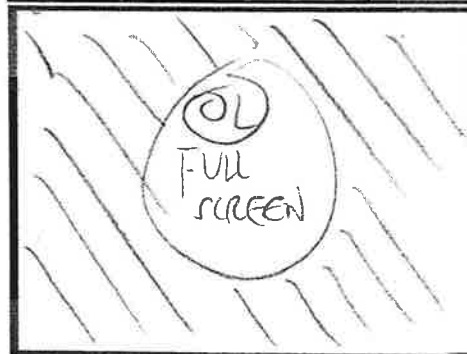

CAN  
←

132 ALEX'S DAD  
...Okay with you?

TECHNIQUE

scène	Cam . reu	Time



CAN  
←

133 ALEX  
I thought you didn't like driving in the dark.

TECHNIQUE

scène	Cam . reu	Time



CAN  
←

134 ALEX'S DAD  
I don't.  
So we'll have to stay over, drive back tomorrow.

TECHNIQUE

### ELLIPSANIME



# #CZ

## EPISODE : BEST XMAS EVER



	PAGE
	88

scène	Cam . reu	Time

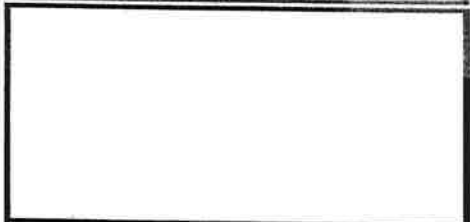
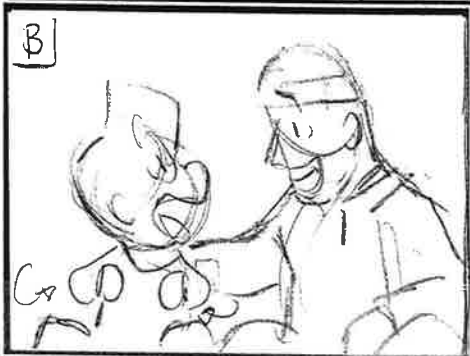

135 ALEX  
Really?

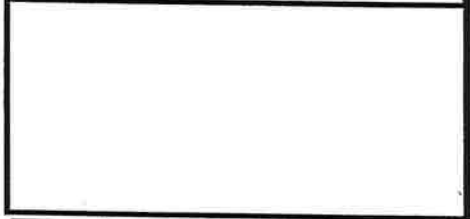

scène	Cam . reu	Time

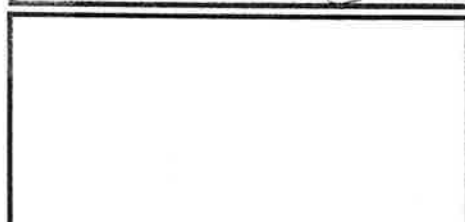

136 ALEX'S DAD  
(nodding)  
Uh-huh. How about a nice hot  
chocolate, then a pre-game warm-up.  
Sound good?

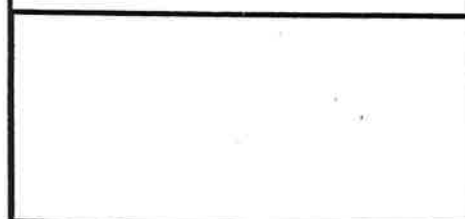

scène	Cam . reu	Time

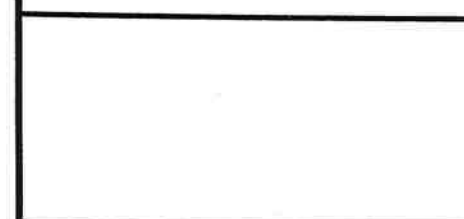
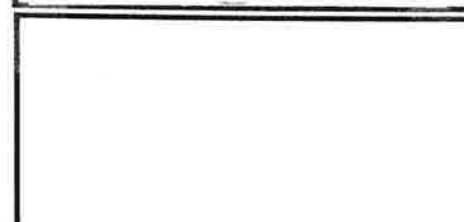

scène	Cam . reu	Time

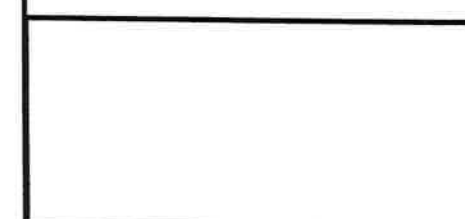

ACTION

DIALOGUES

TECHNIQUE

### ELLIPSANIME



# BIG

# #CZ

## EPISODE : BEST XMAS EVER



	PAGE
	89

scène	Cam . reu	Time
149		

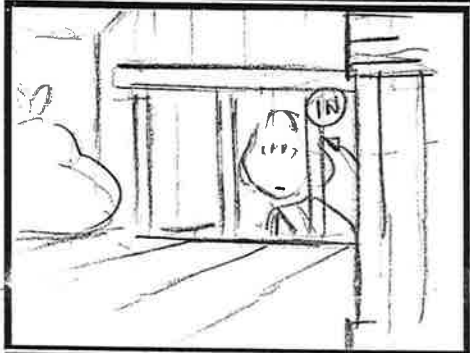

scène	Cam . reu	Time
B1		

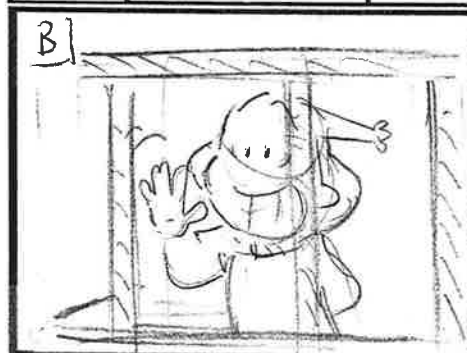

scène	Cam . reu	Time
150		



scène	Cam . reu	Time

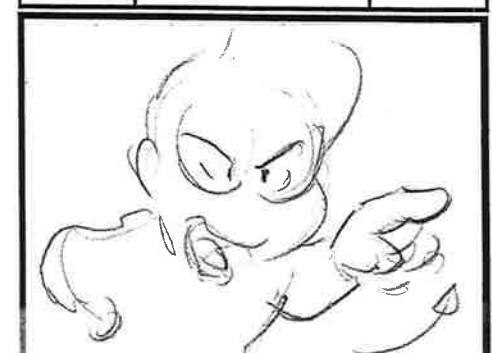

ACTION

DIALOGUES

TECHNIQUE

137 ALEX  
I have a better idea.

How about BG  
makes the hot chocolate?

### ELLIPSANIME



# #CZ

## EPISODE : BEST XMAS EVER



	PAGE
	90

scène	Cam . reu	Time
151		



scène	Cam . reu	Time
152		



scène	Cam . reu	Time



scène	Cam . reu	Time
153		

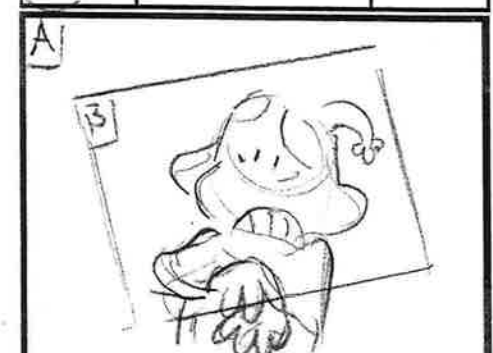

ACTION

DIALOGUES

TECHNIQUE

138 ALEX'S DAD  
What's that red stuff on your face?

TILT TRK (IN) A → B

139 BG (V.O.)  
It was time for me to exit.

### ELLIPSANIME

# BIG

# #CZ

## EPISODE : BEST XMAS EVER



	PAGE
	91

scène	Cam . reu	Time

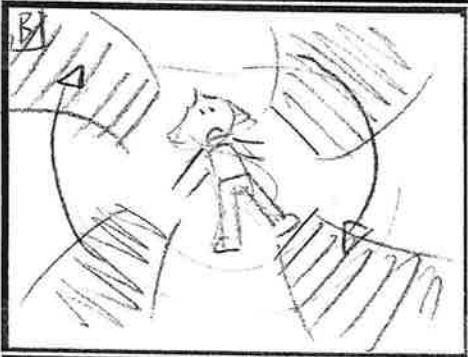

scène	Cam . reu	Time

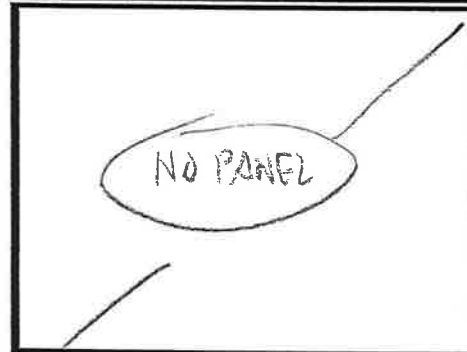

scène	Cam . reu	Time



scène	Cam . reu	Time



ACTION

DIALOGUES

TECHNIQUE

### ELLIPSANiME



# #CZ

## EPISODE : BEST XMAS EVER



	PAGE
	92

scène	Cam . reu	Time
(154)		

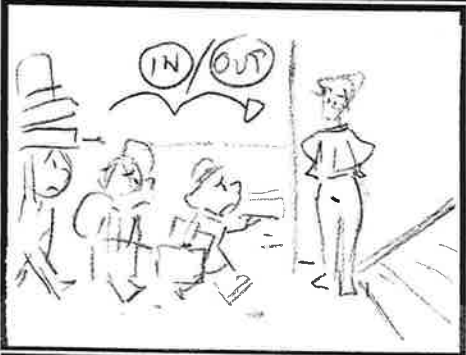

ACTION

DIALOGUES

140 BG (VO)  
Mom made us give all the luggage back.

TECHNIQUE

scène	Cam . reu	Time
(155)		



ACTION

DIALOGUES

141 BG (VO)  
...Just before the big game!

TECHNIQUE

scène	Cam . reu	Time



ACTION

NANAN MET LE STICK A LEVRE VOLÉ SOUS LE NEZ DE GUDULE.

DIALOGUES

141A MOM  
What's this BG?

TECHNIQUE

scène	Cam . reu	Time
(156)		



ACTION

MOM TAPE DU PIED (2)

DIALOGUES

142 BG (VO)  
There were a couple of things left to discuss...

TECHNIQUE

### ELLIPSANIME

# BIG #CZ

EPISODE : BEST XMAS EVER



	PAGE
	93

scène	Cam . reu	Time
157		

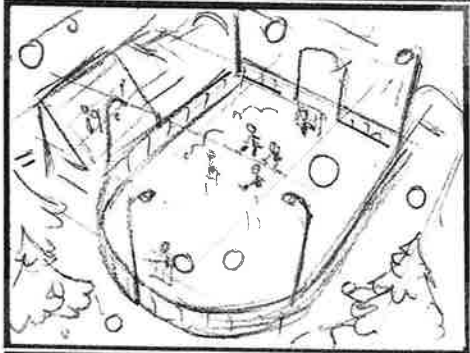

scène	Cam . reu	Time
158		



scène	Cam . reu	Time
159		

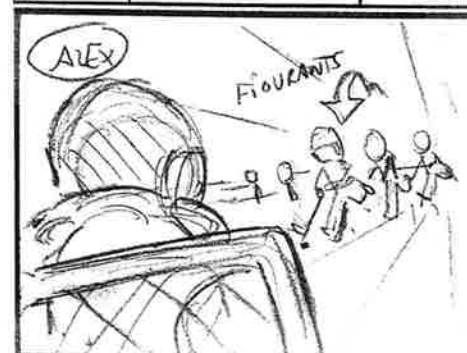

scène	Cam . reu	Time
160		



ACTION

DIALOGUES

TECHNIQUE

**ELLIPSANIME**



# #CZ

## EPISODE : BEST XMAS EVER

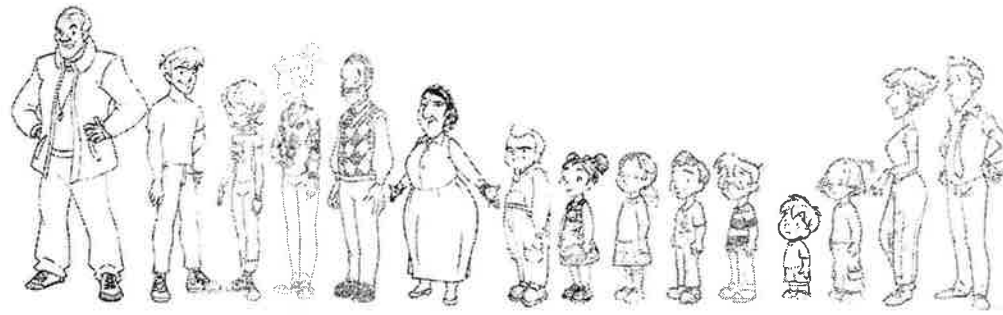

	PAGE
	94

scène	Cam . reu	Time



TRK (OUT) A → B

DIALOGUES

TECHNIQUE

scène	Cam . reu	Time
161		

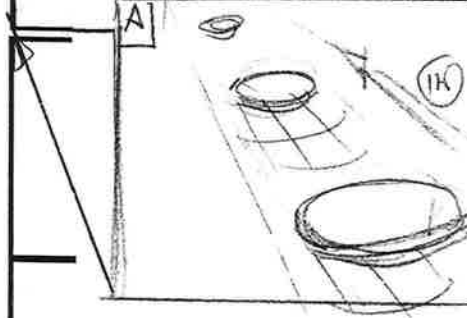

DIALOGUES

scène	Cam . reu	Time

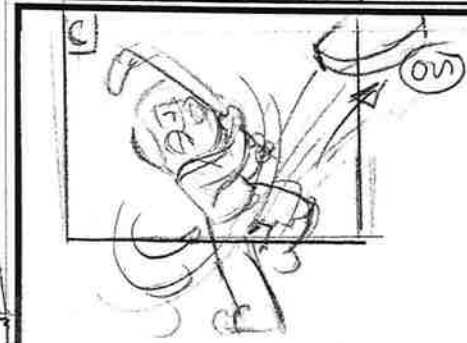

DIALOGUES

TECHNIQUE

scène	Cam . reu	Time



DIALOGUES

DIAL 142A.  
B6. YES - ALRIGHT ALEX  
GAD YEAH ALEX WO-HOO!

TECHNIQUE

### ELLIPSANIME

# BIG #CZ

EPISODE : BEST XMAS EVER



	PAGE
	95

scène	Cam . reu	Time



scène	Cam . reu	Time

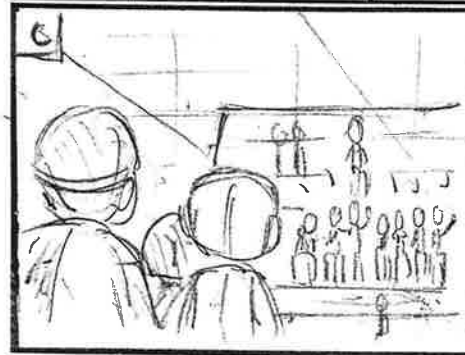

scène	Cam . reu	Time
162		



scène	Cam . reu	Time

ACTION

DIALOGUES

TECHNIQUE

142A ROBBIE, OUMA, ALEX, GAD, ALEX'S DAD, DAD, MOM, BG  
(Cheering walla)

IN ORDER OF APPEARANCE - OUMA - MOM - DAD - ALEX'S non - ROBBIE - ALEX'S DAD -

PAN A → B -

ALEX'S non + DAD  
GET UP.

**ELLIPSANIME**



# #CZ

## EPISODE : BEST XMAS EVER



	PAGE
	96

scène	Cam . reu	Time
163		

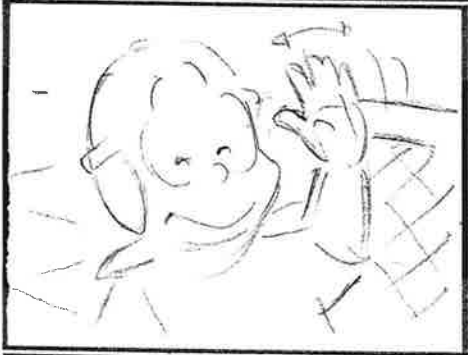

ACTION

DIALOGUES

TECHNIQUE

scène	Cam . reu	Time
164		



LA MERE ET LE PERE  
D'ALEX SE REGARDENT  
ATTENDRI PAR LEUR FILS.

scène	Cam . reu	Time
165		

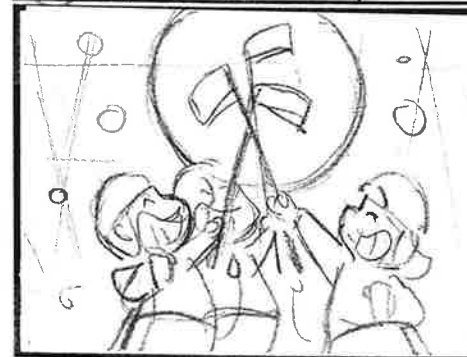

143 BG (VO)  
But this was gonna be the best  
Christmas ever.

scène	Cam . reu	Time



### ELLIPSANIME